



HAL
open science

Active optical-based decoupling circuit for receiver endoluminal coil

R. Aydé, R. Sablong, G. Gaborit, L. Duvillaret, A.-L. Perrier, O. Beuf

► **To cite this version:**

R. Aydé, R. Sablong, G. Gaborit, L. Duvillaret, A.-L. Perrier, et al.. Active optical-based decoupling circuit for receiver endoluminal coil. Joint Annual Meeting ISMRM-ESMRMB 2014, May 2014, Milan, Italy. 13, pp.1274 - 1280, 2013. <hal-01032138>

HAL Id: hal-01032138

<https://hal.science/hal-01032138v1>

Submitted on 17 Jan 2019

HAL is a multi-disciplinary open access archive for the deposit and dissemination of scientific research documents, whether they are published or not. The documents may come from teaching and research institutions in France or abroad, or from public or private research centers.

L'archive ouverte pluridisciplinaire **HAL**, est destinée au dépôt et à la diffusion de documents scientifiques de niveau recherche, publiés ou non, émanant des établissements d'enseignement et de recherche français ou étrangers, des laboratoires publics ou privés.



HAL Authorization

Introduction

Purpose:

To prove the feasibility of an efficient optical circuit for active detuning of an endoluminal receiver coil in a restricted volume.

Background:

- Internal coil provides a local increase in SNR compared to external coil [1]
- Use of metallic coaxial cable within transmit body coil induce local high SAR [2]
- Fiber optic used in transmission of signal and detuning can be a solution [3,4]

Proposition:

A new optical active detuning system is proposed and is associated to an endoluminal coil. Performances are compared with conventional circuit.

Experimental Setup

Material

Coils with different detuning system were compared:

1) Reference coil

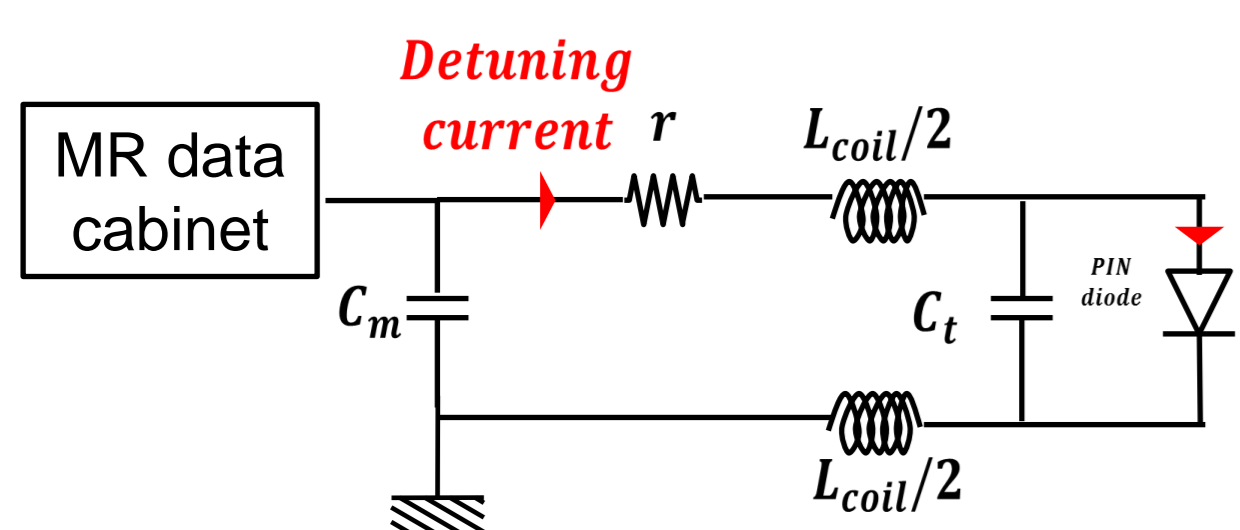

2) Optical detuning coil

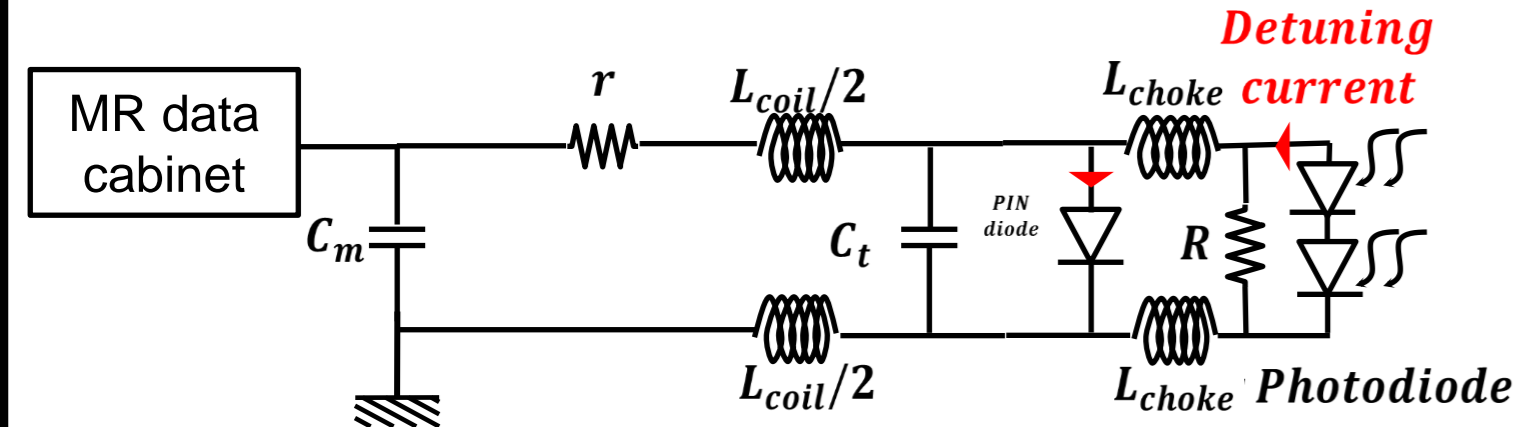

3) Non detuned coil

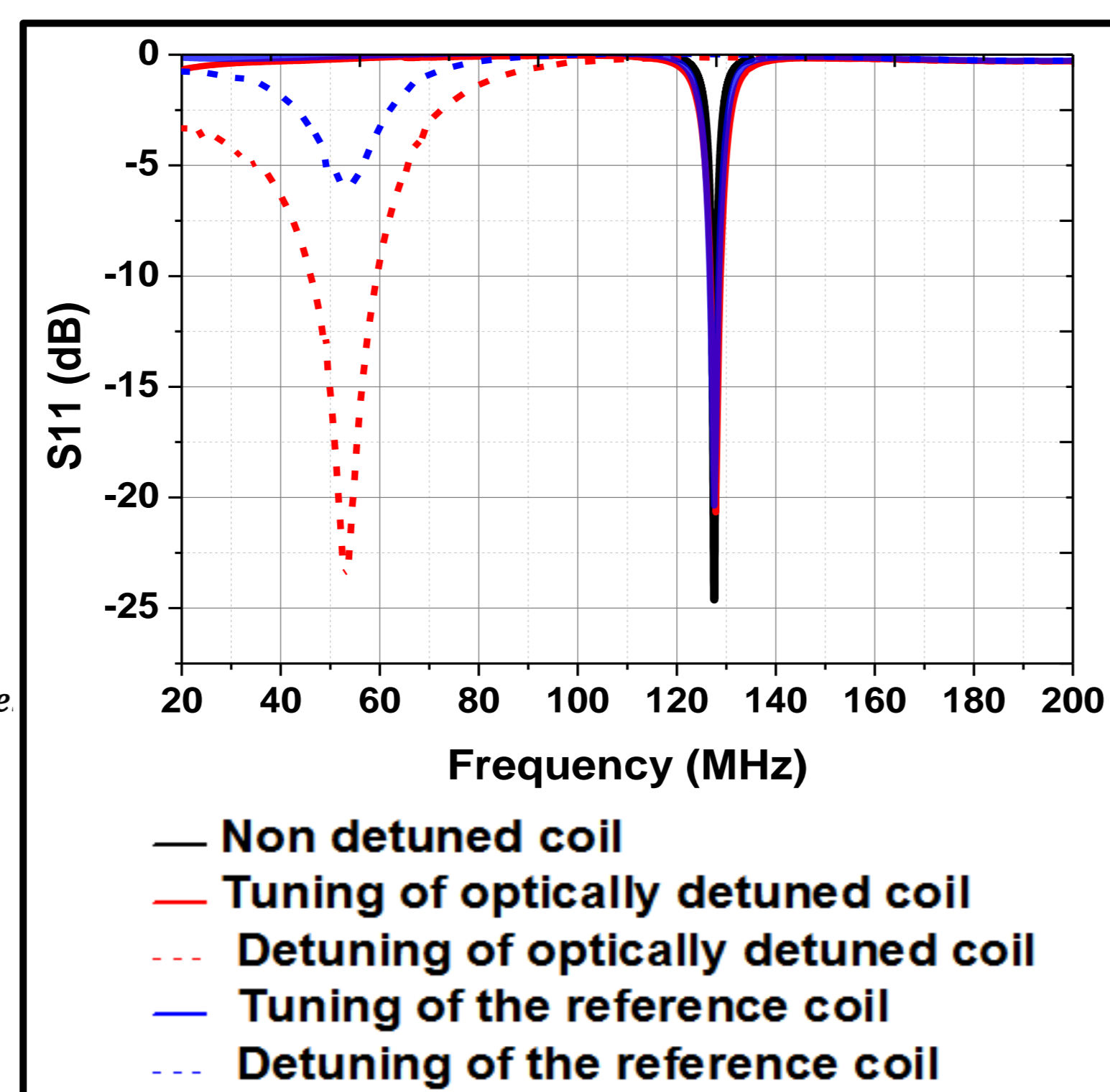
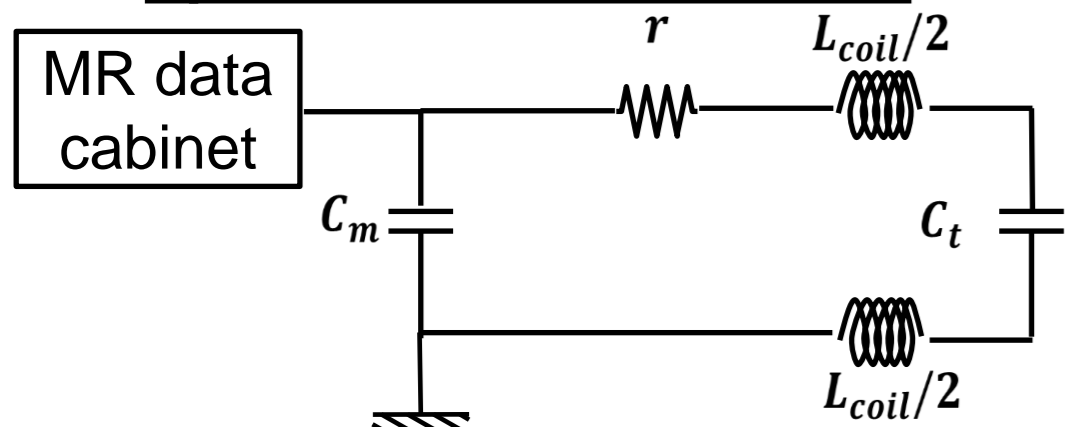

Method

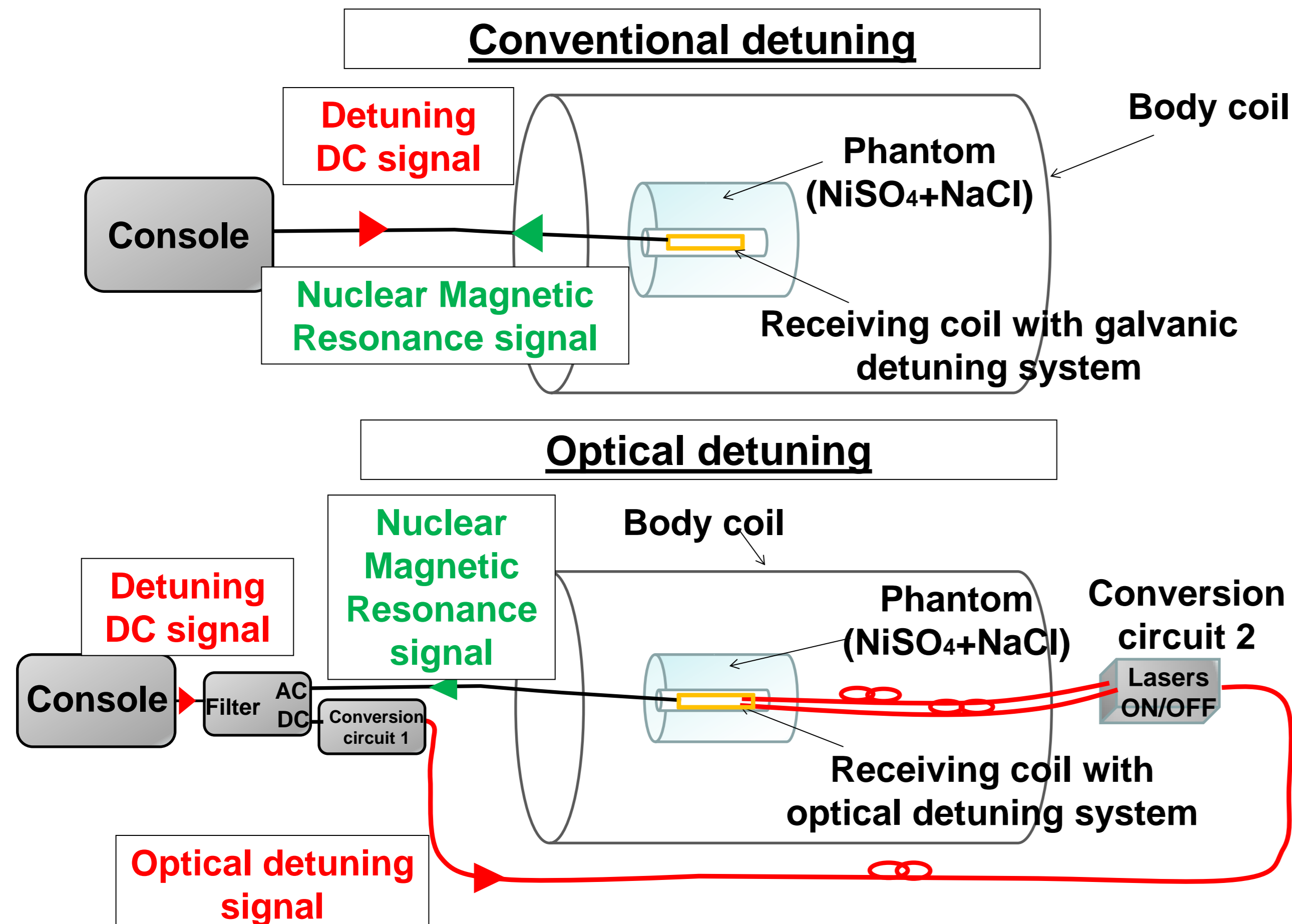

- Detuning of the galvanic regular coil is insured by a PIN diode driven by a current provided by the MR data cabinet.
 - In contrast, the PIN diode of the optical detuning coil is controlled by two photodiodes providing sufficient current for a direct operation. The DC current provided by the data cabinet is converted into an optical signal. Then, the optical signal is converted into the appropriate potential bias of two laser diodes. Photodiodes receive optical beam from laser diodes and generate the detuning current.
 - Coil dimensions: 5.1mm×70mm
 - Phantom dimensions: external D=90mm, inner D=11mm, length=100mm
- Two sequences were applied: FSE and GRE
- FSE: TR/TE=2800/15.4ms, FOV=160×160mm², slice thickness=2mm, matrix=256×256, RBW=25KHz (Pixel RBW=97.66 Hz/Px)
 - GRE: TR/TE=40/11.4ms, Flip angle=80°, FOV=160×160mm², slice thickness=2mm, matrix=256×256, RBW=16.12 KHz (Pixel RBW=62.99 Hz/Px)

Results

MR images

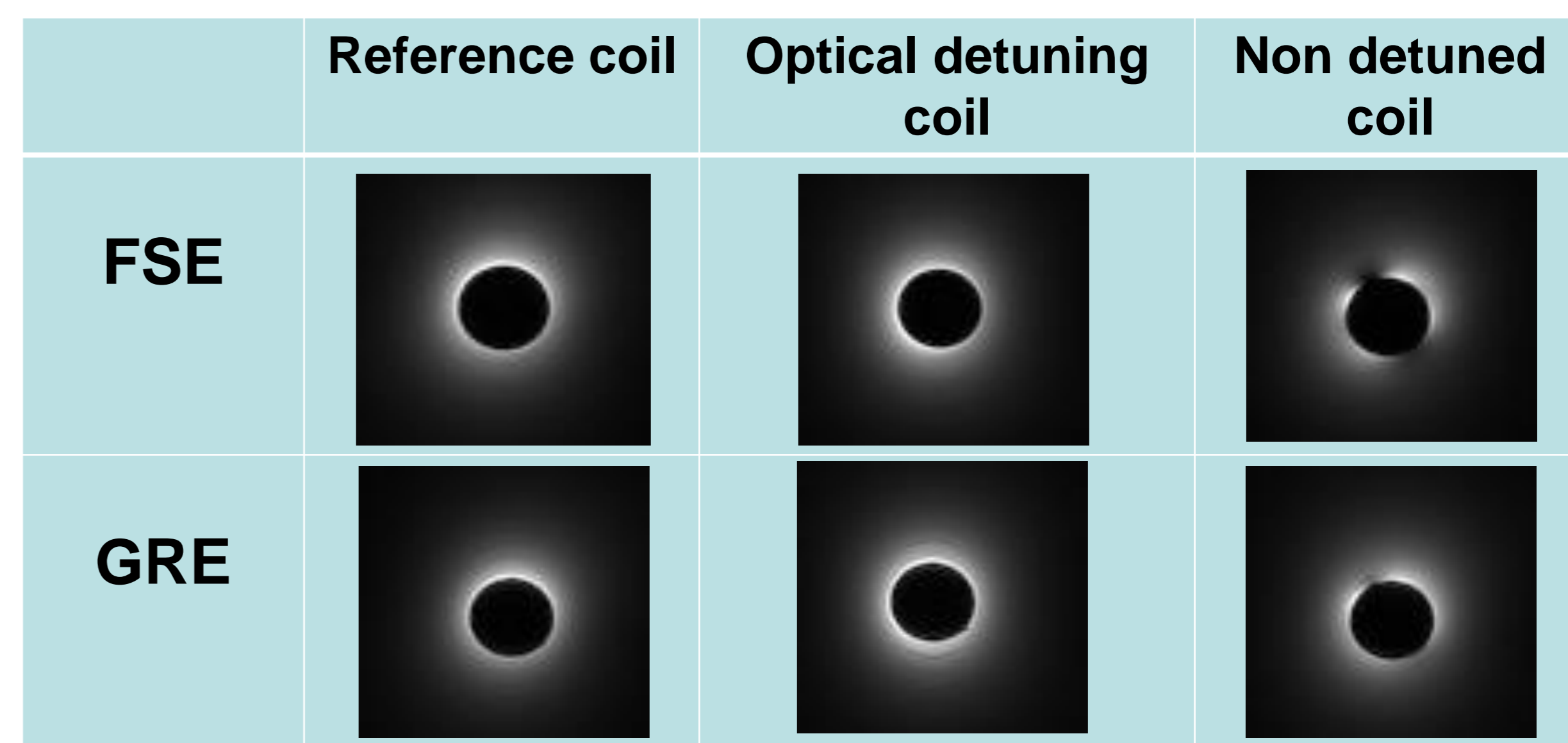

SNR iso-contour

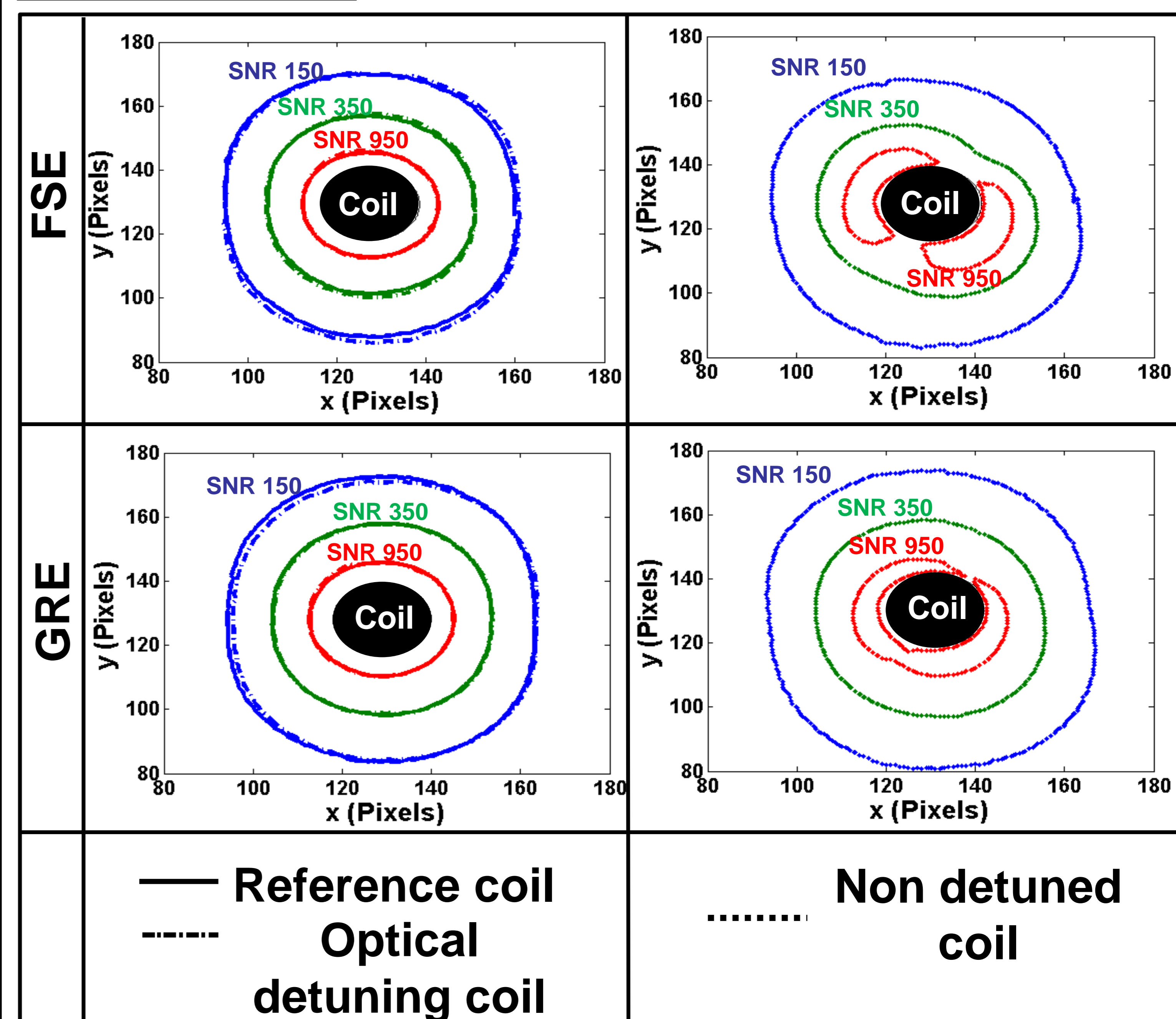

Results:

- SNR iso-contours of the non-detuned coil are deformed especially in the close vicinity of the coil. In fact, during RF transmission, a current is induced in the non-detuned coil affecting, thus, the uniformity of B1 excitation field.
- SNR iso-contours of reference coil and optical detuning coil almost overlap for FSE and GRE sequences at all distances.

Conclusion

- No current is induced into the optical detuning coil during RF transmission demonstrating that the optical-based detuning system performs with adequacy.

Perspectives

- Design and realization of an endoluminal coil associated to an ElectroOptic waveguide to ensure optical transmission of the MR signal[5]
- NMR imaging with this full optical device.

[1] Beuf O, Pilleul F, Armenean M, Hadour G, Saint-Jalmes H. In vivo colon wall imaging using endoluminal coils: feasibility study on rabbits. J Magn Reson Imaging 2004;20:90-96.

[2] Yeung CJ, Susil RC, Atalar E. RF safety of wires in interventional MRI: using a safety index, Proceedings of IEEE EMBC; the 23rd Annual International Conference, Turkey; October 2001.

[3] Fandrey S, Weiss S, Muller J. A novel active MR probe using a miniaturized optical link for a 1.5-T MRI scanner. Magn Reson Med, 2012;67:148-155.

[4] Korn M, Umatham R, Schulz J, Semmler W, Bock M. Optically detunable, inductively coupled coil for self-gating in small animal magnetic resonance imaging. Magn Reson Med 2011;65:882-888.

[5] Ayde R, Gaborit G, Jarrige P, Duvillaret L, Sablong R, Perrier AL, Beuf O. Potentialities of an electro-optic crystal fed by nuclear magnetic resonant coil for remote and low-invasive magnetic field characterization. IEEE Sensors J 2013;13:1274-1280.