



HAL
open science

On the Reversibility of Well-Behaved Weighted Choice-Free Systems

Thomas Hujsa, Jean-Marc Delosme, Alix Munier-Kordon

► **To cite this version:**

Thomas Hujsa, Jean-Marc Delosme, Alix Munier-Kordon. On the Reversibility of Well-Behaved Weighted Choice-Free Systems. 35th International Conference on Application and Theory of Petri Nets and Concurrency, PETRI NETS 2014, Jun 2014, Tunis, Tunisia. pp.334-353, 10.1007/978-3-319-07734-5_18 . hal-01017044

HAL Id: hal-01017044

<https://hal.science/hal-01017044v1>

Submitted on 13 May 2019

HAL is a multi-disciplinary open access archive for the deposit and dissemination of scientific research documents, whether they are published or not. The documents may come from teaching and research institutions in France or abroad, or from public or private research centers.

L'archive ouverte pluridisciplinaire **HAL**, est destinée au dépôt et à la diffusion de documents scientifiques de niveau recherche, publiés ou non, émanant des établissements d'enseignement et de recherche français ou étrangers, des laboratoires publics ou privés.

On the Reversibility of Well-Behaved Weighted Choice-Free Systems

Thomas Hujsa^{1,*}, Jean-Marc Delosme², and Alix Munier-Kordon¹

¹ Sorbonne Universités, UPMC Paris 06, UMR 7606, LIP6, F-75005, Paris, France

{Thomas.Hujsa,Alix.Munier}@lip6.fr,

² Université d'Evry-Val-D'Essonne, IBISC, 91025, Evry, France

Jean-Marc.Delosme@ibisc.univ-evry.fr

Abstract. A Petri net is reversible if its initial marking is a home marking, a marking reachable from any reachable marking. Under the assumption of well-behavedness we investigate the property of reversibility for strongly connected weighted Choice-Free Petri nets, nets which structurally avoid conflicts. Several characterizations of liveness and reversibility as well as exponential methods for building live and home markings are available for these nets. We provide a new characterization of reversibility leading to the construction in polynomial time of an initial marking with a polynomial number of tokens that is live and reversible. We also introduce a polynomial time transformation of well-formed Choice-Free systems into well-formed T-systems and we deduce from it a polynomial time sufficient condition of liveness and reversibility for well-formed Choice-Free systems. We show that neither one of these two approaches subsumes the other.

Keywords: Reversibility, well-behavedness, polynomial conditions, decomposition, place-splitting transformation, weighted Petri nets, Choice-Free, Fork-Attribution, T-system

1 Introduction

Weighted Choice-Free Petri nets constrain every place to have at most one output transition, hence structurally avoid conflicts. They extend the expressiveness of weighted T-systems, also known as generalized Event Graphs, which are equivalent to Synchronous Data Flow graphs (SDF)[1] and have been widely used to model embedded applications. Choice-Free Petri nets are called *output-nonbranching* in [2], where they are shown to be distributable.

Home markings can be reached from any reachable marking. Used as an initial data distribution of the system, they avoid a transient phase and define a reversible Petri net. In this context, all reachable markings remain reachable after any firing sequence. This reversibility property is often required in embedded applications that need a steady behavior. Moreover, the study of the reachability graph is consequently simplified.

* The work of this author is supported by Digiteo / Project Tatami.

Relationship with well-behavedness. Embedded systems have to keep all their functions active over time within bounded memory. In Petri nets, these requirements are formalized by the notions of liveness and boundedness, which, taken together, define well-behavedness. The objective is to build systems that are well-behaved and reversible. However, live systems are not necessarily reversible, while reversibility does not imply liveness [3]. In this paper, we focus on the reversibility property under the well-behavedness hypothesis. Since the well-formedness property, defining structural liveness and structural boundedness, is necessary for the well-behavedness of Choice-Free systems [4], we focus on systems that are well-formed.

Previous results. All strongly connected well-behaved T-systems are known to be reversible [5]. Characterizations of liveness, well-behavedness and reversibility have been found for the class of Choice-Free systems [4], even though reversibility may not be deduced from well-behavedness for these systems. However, the existing reversibility condition is expressed in terms of the ability to fire a sequence whose size is exponential and does not lead trivially to a polynomial time algorithm for checking the reversibility or building a reversible marking of reasonable size. Live and reversible initial markings for Choice-Free systems are constructed in [4] by finding a solution of an integer linear program with an exponential number of constraints.

Home markings have also been studied in other subclasses of weighted Petri nets. For instance, in Workflow nets, reversibility in a variant of the system provides information on other behavioral properties [6]. The existence of home markings is stated for Equal-Conflict systems, which generalize Choice-Free systems [7], as well as the class of DSSP, which simulate Equal-Conflict systems [8]. However, the construction of home markings is not provided for these classes.

Another approach for studying the behavior consists in transforming the system while preserving some properties. Many transformation rules have been proposed, some of which can be found in [3,9,10,11]. However, they do not apply to the complete class of systems studied in this paper.

Contributions. We propose two new approaches for studying the reversibility of well-behaved Choice-Free systems.

First, extending a liveness characterization of [4], we show that the reversibility of a Choice-Free system can be expressed in terms of the reversibility of particular subsystems belonging to the Fork-Attribution class, where transitions have at most one input. This decomposition leads to the first live and reversible initial marking for Choice-Free systems that is constructed in polynomial time with a polynomial number of tokens, contrasting with previous exponential methods.

We focus then on well-formed Choice-Free systems, for which we provide a polynomial time transformation into a well-formed T-system by splitting places having several inputs while preserving the set of T-semiflows. Using a known polynomial time sufficient condition of liveness for well-formed T-systems, we obtain a polynomial time sufficient condition of liveness and reversibility for well-formed Choice-Free systems. We show that this condition neither implies

the marking construction nor is induced by this marking. Thus both approaches are worthy of interest.

Organization of the paper. In Section 2, we recall general definitions, notations and properties of Petri nets. Several structural and behavioral properties of Choice-Free systems are also detailed. In Section 3, we present the new characterization of reversibility and the construction of the polynomial live and home marking. We study then the particular case of T-systems. In Section 4, the place splitting transformation is detailed, as well as the new polynomial time sufficient condition of liveness and reversibility. Finally, the two conditions are compared.

2 Definitions, Notations and Properties

We first recall definitions and notations for weighted nets, markings, systems and firing sequences. Classical notions, such as liveness and boundedness, are formalized. We also consider particular subnets, subsystems and subsequences. We then present the special classes of nets considered in this paper, namely Choice-Free nets and some of their subclasses. Finally, we recall general results on the structure and behavior of Choice-Free nets.

2.1 Weighted and Ordinary Nets

A (*weighted*) *net* is a triple $N = (P, T, W)$ where:

- the sets P and T are finite and disjoint, T contains only transitions and P only places,
- $W : (P \times T) \cup (T \times P) \mapsto \mathbb{N}$ is a weight function.

$P \cup T$ is the set of the elements of the net.

An arc is present from a place p to a transition t (resp. a transition t to a place p) if $W(p, t) > 0$ (resp. $W(t, p) > 0$). An *ordinary* net is a net whose weight function W takes values in $\{0, 1\}$.

The *incidence matrix* of a net $N = (P, T, W)$ is a place-transition matrix C defined as

$$\forall p \in P \quad \forall t \in T, \quad C[p, t] = W(t, p) - W(p, t)$$

where the weight of any non-existing arc is 0.

The *pre-set* of the element x of $P \cup T$ is the set $\{w | W(w, x) > 0\}$, denoted by $\bullet x$. By extension, for any subset E of P or T , $\bullet E = \bigcup_{x \in E} \bullet x$.

The *post-set* of the element x of $P \cup T$ is the set $\{y | W(x, y) > 0\}$, denoted by x^\bullet . Similarly, $E^\bullet = \bigcup_{x \in E} x^\bullet$.

We denote by \max_p^N the maximum output weight of p in the net N and by \gcd_p^N the greatest common divisor of all input and output weights of p in the net N . The simpler notations \max_p and \gcd_p are used when no confusion is possible.

A *source place* has at least one output transition and no input transition. A *join-transition* has at least two input places. A net is *well-connected* if it is connected and each place and transition has at least one input.

2.2 Markings, Systems and Firing Sequences

A *marking* M of a net N is a mapping $M : P \rightarrow \mathbb{N}$. We shall also denote by M the column vector whose components are the values $M(p)$ for $p \in P$. A *system* is a couple (N, M_0) where N is a net and M_0 its initial marking.

A marking M of a net N *enables* a transition $t \in T$ if $\forall p \in \bullet t, M(p) \geq W(p, t)$. A marking M *enables* a place $p \in P$ if $M(p) \geq \max_p$. The marking M' obtained from M by the firing of an enabled transition t , noted $M \xrightarrow{t} M'$, is defined by $\forall p \in P, M'(p) = M(p) - W(p, t) + W(t, p)$.

A *firing sequence* σ of length $n \geq 1$ on the set of transitions T is a mapping $\{1, \dots, n\} \rightarrow T$. A sequence is *infinite* if its domain is countably infinite. A firing sequence $\sigma = t_1 t_2 \dots t_n$ is *feasible* if the successive markings obtained, $M_0 \xrightarrow{t_1} M_1 \xrightarrow{t_2} M_2 \dots \xrightarrow{t_n} M_n$, are such that M_{i-1} enables the transition t_i for any $i \in \{1, \dots, n\}$. We note $M_0 \xrightarrow{\sigma} M_n$.

The *Parikh vector* $\vec{\sigma} : T \rightarrow \mathbb{N}$ associated with a finite sequence of transitions σ maps every transition t of T to the number of occurrences of t in σ .

A marking M' is said to be *reachable* from the marking M if there exists a feasible firing sequence σ such that $M \xrightarrow{\sigma} M'$. The set of markings reachable from M is denoted by $[M]$.

A *home marking* is a marking that can be reached from any reachable marking. Formally, M is a home marking in the system (N, M_0) if $\forall M' \in [M_0], M \in [M']$. A system is *reversible* if its initial marking is a home marking.

2.3 Liveness and Boundedness

Liveness and boundedness are two basic properties ensuring that all transitions of a system $S = (N, M_0)$ can always be fired and that the overall number of tokens remains bounded. More formally,

- A system S is *live* if for every marking M in $[M_0]$ and for every transition t , there exists a marking M' in $[M]$ enabling t .
- S is *bounded* if there exists an integer k such that the number of tokens in each place never exceeds k . Formally, $\exists k \in \mathbb{N} \forall M \in [M_0] \forall p \in P, M(p) \leq k$.
 S is *k-bounded* if, for any place $p \in P$, $k \geq \max\{M(p) | M \in [M_0]\}$.
- A system S is *well-behaved* if it is live and bounded.

A marking M is live (resp. bounded) for a net N if the system (N, M) is live (resp. bounded). The structure of a net N may be studied to ensure the existence of an initial marking M_0 such that (N, M_0) is live and bounded:

- N is *structurally live* if a marking M_0 exists such that (N, M_0) is live.
- N is *structurally bounded* if the system (N, M_0) is bounded for each M_0 .
- N is *well-formed* if it is structurally live and structurally bounded.

The algebraic properties of consistency and conservativeness are necessary conditions for well-formedness for all weighted Petri nets [12,13]. They are defined next in terms of the existence of particular annullers of the incidence matrix.

2.4 Semiflows, Consistency and Conservativeness

Semiflows are particular left or right annulers of an incidence matrix C that is supposed to be non-empty:

- A P-semiflow is a non-null vector $X \in \mathbb{N}^{|P|}$ such that ${}^tX \cdot C = 0$.
- A T-semiflow is a non-null vector $Y \in \mathbb{N}^{|T|}$ such that $C \cdot Y = 0$.

A P-semiflow is *minimal* if the greatest common divisor of its components is equal to 1 and its support is not a proper superset of the support of any other P-semiflow. The same definition applies to T-semiflows.

We denote by $\mathbb{1}^n$ the column vector of size n whose components are all equal to 1. The conservativeness and consistency properties are defined as follows using the incidence matrix C of a net N :

- N is *conservative* if a P-semiflow $X \in \mathbb{N}^{|P|}$ exists for C such that $X \geq \mathbb{1}^{|P|}$.
- N is *consistent* if a T-semiflow $Y \in \mathbb{N}^{|T|}$ exists for C such that $Y \geq \mathbb{1}^{|T|}$.

The net on Figure 1 is conservative and consistent.

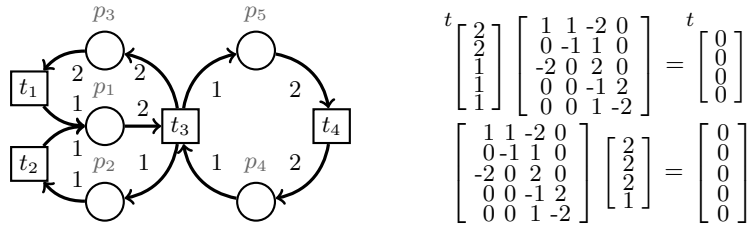

Fig. 1. This weighted net is conservative (the *left vector* $[2, 2, 1, 1, 1]$ is a P-semiflow and its components are ≥ 1) and consistent (the *right vector* ${}^t[2, 2, 2, 1]$ is a T-semiflow and its components are ≥ 1).

2.5 P-subnets, P-subsystems and Subsequences

The sequence σ' is a *subsequence* of the sequence σ if σ' is obtained from σ by removing some transitions of σ . The *restriction of σ to the set $T' \subseteq T$ of transitions* is the maximum subsequence of σ whose transitions belong to T' .

The net $N' = (P', T', W')$ is a *P-subnet* of $N = (P, T, W)$ if P' is a subset of P , $T' = \bullet P' \cup P' \bullet$ and W' is the restriction of W to P' and T' . Figure 2 shows two P-subnets of the net in Figure 1.

The system $S' = (N', M'_0)$, with $N' = (P', T', W')$, is a *P-subsystem* of $S = (N, M_0)$ if N' is a P-subnet of N and its initial marking M'_0 is restricted to P' , *i.e.* $M'_0 = M_0|_{P'}$.

2.6 Choice-Free Nets and Subclasses

$N = (P, T, W)$ is a (weighted) *Choice-Free net* if each place has at most one output transition, *i.e.* $\forall p \in P, |p^\bullet| \leq 1$. A *T-net* (Event Graph) is a Choice-Free net such that each place has at most one input transition, *i.e.* $\forall p \in P, |\bullet p| \leq 1$. A *Fork-Attribution net* (or FA net) is a Choice-Free net in which transitions have at most one input place, *i.e.* $\forall t \in T, |\bullet t| \leq 1$.

The nets presented in Figures 1 and 2 are Choice-Free. The net on the left hand side of Figure 2 is an FA net while the net on the right hand side is a circuit, hence a particular T-net and FA net.

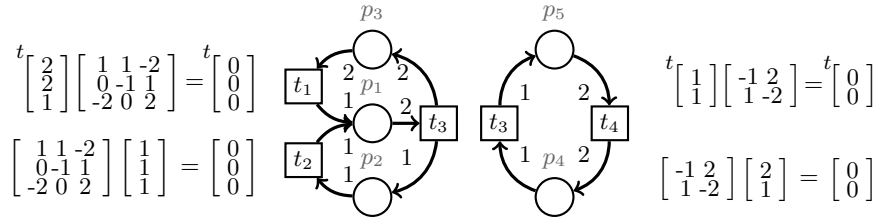

Fig. 2. Two FA P-subnets of the net of Figure 1. On the left, the P-subnet is defined by the set of places $\{p_1, p_2, p_3\}$. The net on the right is defined by the set of places $\{p_4, p_5\}$. Moreover, these two nets are conservative and consistent.

In this paper, we focus on well-formed Choice-Free nets. We recall next properties of Choice-Free systems that arise from their absence of conflicts and deal with well-formedness, liveness and firing sequences. The next proposition expresses a necessary and sufficient condition of well-formedness for this class and states its necessity for well-behavedness, which is not the case for all Petri nets.

Proposition 1 ([4]). *Suppose that N is a weighted and strongly connected Choice-Free net. The properties*

- N is consistent and conservative
- N is well-formed

are equivalent. Moreover, if a marking M_0 exists such that (N, M_0) is well-behaved, then N is well-formed.

Figure 1 shows a strongly connected, consistent and conservative, thus well-formed, Choice-Free net. Similarly, the two nets of Figure 2 are well-formed.

The existence of T-semiflows induces strong structural and behavioral properties. In the case of well-formed Choice-Free nets, they are detailed below.

Proposition 2 ([4]). *If $N = (P, T, W)$ is a well-formed and strongly connected Choice-Free net, then N has a unique minimal T-semiflow Y . Moreover, the support of Y is the whole set T .*

A decomposition theory has been developed for Choice-Free systems and larger classes [4,14], allowing to get insight into their structure and behavior by studying particular subsystems. The next results show the relevance of FA P-subsystems to the study of well-formedness and liveness in Choice-Free systems.

Proposition 3 ([4]). *Consider a strongly connected well-formed Choice-Free net N with unique minimal T -semiflow Y . If $N_* = (P_*, T_*, W_*)$ is a strongly connected FA P-subnet of N then N_* is well-formed, with a unique minimal T -semiflow Y_* , and $Y|_{T_*}$ is a multiple of Y_* . Moreover, N is covered by such FA P-subnets.*

The strongly connected well-formed Choice-Free net of Figure 1 is covered by the FA P-subnets of Figure 2, which are strongly connected and well-formed.

Proposition 4 ([4]). *Consider a Choice-Free system $S = (N, M_0)$ without source places. S is live if and only if all the strongly connected FA P-subsystems $S_* = ((P_*, T_*, W_*), M_0|_{P_*})$ of S are live.*

This characterization of liveness in terms of subsystems does not trivially lead to an efficient algorithm for checking liveness, as one may have to check an exponential number of subsystems.

A system is persistent if every reachable marking M that enables two transitions t_1 and t_2 enables the sequence $t_1 t_2$. Persistent systems encompass the structurally persistent Choice-Free systems and have a *confluent* language [4,15,16,17]. This property is also known as the *Church-Rosser* property in the context of rewriting systems. A constructive theorem of confluence for persistent systems exists [16], however, we only need the following one, illustrated in Figure 3.

Proposition 5 (Confluence ([4])). *Consider a Choice-Free system (N, M_0) . If M_1 and M_2 are reachable markings such that $M_0 \xrightarrow{\sigma} M_1$ and $M_0 \xrightarrow{\tau} M_2$ then a marking M_3 exists such that $M_1 \xrightarrow{\alpha} M_3$ and $M_2 \xrightarrow{\beta} M_3$, where the feasible sequences α and β satisfy the following conditions for every transition t :*

$$\begin{aligned}\bar{\alpha}(t) &= \max\{\bar{\sigma}(t), \bar{\tau}(t)\} - \bar{\sigma}(t) \\ \bar{\beta}(t) &= \max\{\bar{\sigma}(t), \bar{\tau}(t)\} - \bar{\tau}(t).\end{aligned}$$

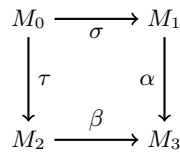

Fig. 3. If the sequences σ and τ are feasible in the Choice-Free system, then the feasible sequences α and β exist and reach the same marking M_3 .

3 Reversibility of Well-Behaved Choice-Free Systems

In Choice-Free systems, well-behavedness does not imply reversibility [4]. Under the well-behavedness hypothesis, we provide a new necessary and sufficient condition of reversibility that is expressed in terms of the reversibility of particular subsystems, namely strongly connected FA P-subsystems. This result extends the liveness condition of Proposition 4 for well-formed Choice-Free systems, improving our understanding of their behavior from the decomposition point of view. To prove this condition, we exploit a known characterization of reversibility as well as a property of the sequences that are feasible in P-subsystems. Moreover, this approach allows to construct, for these systems, a *polynomial*, meaning in polynomial time with a polynomial number of tokens, live and reversible initial marking, whereas the older characterization gives no direct solution to this problem. Finally, we compare our result to the liveness and reversibility of the T-system subclass, in which the interesting P-subnets are circuits.

3.1 A Known Necessary and Sufficient Condition of Reversibility

A characterization of reversibility for well-behaved Choice-Free systems, presented in [4], is recalled below. This statement relies on the feasibility of a sequence whose Parikh vector is equal to the minimal T-semiflow.

Proposition 6 ([4]). *Consider a well-behaved and strongly connected Choice-Free system $S = (N, M_0)$ with unique minimal T-semiflow Y . S is reversible if and only if a sequence σ_Y such that $\vec{\sigma}_Y = Y$ is feasible at M_0 .*

This proposition is used in the sequel to prove the new reversibility condition.

3.2 Preliminary Result About Subsequences and P-subsystems

We present a general technical result that deals with the restriction of sequences to P-subsystems. Such subsequences have been used in [14].

Lemma 1. *Consider a system $S = (N, M_0)$, where $N = (P, T, W)$, together with one of its P-subsystems $S' = (N', M_0|_{P'})$, where $N' = (P', T', W')$. For every feasible sequence σ in S , the subsequence $\sigma|_{T'}$ is feasible in S' . Moreover, if $M_0 \xrightarrow{\sigma} M$ in S and $M_0|_{P'} \xrightarrow{\sigma|_{T'}} M'$ in S' , then $M|_{P'} = M'$.*

Proof. We prove the claim by induction on the size of a feasible sequence of size k in S . If σ is empty, it is feasible in both systems and the marking is unchanged.

Hence, suppose that $\sigma = \sigma_1 t$ is feasible in S , where σ_1 has size $k - 1$, and that the claim is true when the size of the sequence is strictly smaller than k . We note $M_0 \xrightarrow{\sigma_1} M_1 \xrightarrow{t} M_2$ in S . By the induction hypothesis, $\sigma_1|_{T'}$ is feasible in S' , we note $M_0|_{P'} \xrightarrow{\sigma_1|_{T'}} M'_1$ in S' , and for every place p in P' , $M_1(p) = M'_1(p)$.

As S' is a P-subsystem of S , a transition belongs to T' if and only if it is an input or output of at least one place of P' .

If t is not in T' then $\sigma_{1|T'}$ equals $\sigma|_{T'}$, which is thus feasible in S' . Moreover, t does not modify the marking of places in P' , thus $M'_1 = M_2|_{P'}$.

Otherwise t belongs to T' and is enabled in (N, M_1) . Moreover, $M_1|_{P'} = M'_1$, implying that the input places of t that belong to P' are enabled in (N', M'_1) , thus t is enabled in (N', M'_1) . We note $M'_1 \xrightarrow{t} M'_2$. Finally, a place p in P' is an input or output of t in N if and only if it is one or the other in N' thus $M_2|_{P'} = M'_2$. \square

3.3 A New Necessary Condition of Reversibility

As mentioned earlier, we focus on strongly connected well-behaved Choice-Free systems. We present here the necessity part of our characterization of reversibility. For that purpose, we need the following lemma, deduced from [4].

Lemma 2 ([4]). *Consider a strongly connected and well-formed Choice-Free system $S = (N, M_0)$ with minimal T-semiflow Y . If there exists a positive integer k , $k \geq 1$, and a feasible sequence σ in S such that $\vec{\sigma} = k \cdot Y$, then there exists a feasible sequence σ_Y in S such that $\vec{\sigma}_Y = Y$.*

Now we are able to prove the necessary condition of reversibility.

Theorem 1. *Consider a strongly connected and well-behaved Choice-Free system $S = ((P, T, W), M_0)$. The reversibility of S implies the reversibility of each of its strongly connected FA P-subsystems.*

Proof. By Propositions 1 and 2, S is well-formed and has a unique minimal T-semiflow Y whose support is the whole set T . S is reversible, thus by Proposition 6, there exists a sequence σ_Y that is feasible in S and whose Parikh vector is equal to Y . Consider $S_* = ((P_*, T_*, W_*), M_0|_{P_*})$ a strongly connected FA P-subsystem of S , with minimal T-semiflow Y_* . The sequence $\sigma_Y|_{T_*}$ is feasible in S_* by Lemma 1. Moreover $\vec{\sigma}_Y|_{T_*} = Y|_{T_*}$ and $Y|_{T_*}$ is a multiple of Y_* by Proposition 3. We deduce that $\vec{\sigma}_Y|_{T_*}$ is a multiple of Y_* . Thus, by Lemma 2, there exists a sequence σ_{Y_*} feasible in S_* and with Parikh vector equal to Y_* . By Proposition 6, S_* is reversible. \square

3.4 A New Characterization of Reversibility

We prove the sufficiency part of the characterization, stating that the non-reversibility of the whole system implies the existence of a non-reversible FA P-subsystem. For that purpose, we formalize below relations between T-semiflows and reversibility with the help of several definitions, and an intermediate characterization of reversibility that involves firing sequences. Then, using decomposition arguments, we prove the main characterization of reversibility.

Definition 1. *Consider a system $S = (N, M_0)$ having a T-semiflow Y . A sequence σ that is feasible in S is transient relative to Y if its Parikh vector is smaller but not equal to Y , that is $\vec{\sigma}(t) \leq Y(t)$ for every transition t and $\vec{\sigma}(t') < Y(t')$ for at least one transition t' . The firing of σ in S , leading to a marking M , induces a transient system denoted by the vector (N, M, σ, Y) .*

In order to simplify our study of transient sequences and systems, we partition the places and transitions into *ready* and *frozen* ones, as specified below.

Definition 2. Consider a transient system $S = (N, M, \sigma, Y)$. A transition t is ready in S if $\vec{\sigma}(t) < Y(t)$, otherwise the transition is frozen in S , in which case $\vec{\sigma}(t) = Y(t)$. A place is ready in S if it is an input of a transition that is ready in S , otherwise it is frozen in S .

In a system that is transient relative to a T-semiflow Y , the firing of a ready transition reduces the number of steps to attain Y . However, ready transitions may not be enabled. We formalize next the notion of blocking systems, whose ready transitions cannot be fired.

Definition 3. A transient system is blocking if it contains no enabled ready transition.

Hence, we focus on strongly connected well-behaved Choice-Free systems, which are well-formed (Proposition 1) and have a unique minimal T-semiflow whose support contains all transitions (Proposition 2). Thus, the Parikh vector of any feasible sequence is smaller than some multiple of the minimal T-semiflow Y . If such a system $S = (N, M, \sigma, Y')$ is blocking then liveness induces the existence of an enabled frozen transition in S and Y' is the smallest multiple of Y that is greater than $\vec{\sigma}$. For these systems, the following characterization of reversibility is an alternative to Proposition 6 that involves blocking systems.

Theorem 2. Consider a strongly connected Choice-Free system S that is well-behaved. S is reversible if and only if there exists no feasible sequence in S that leads to a blocking system.

Proof. To prove that the system is reversible, it suffices to consider the empty sequence, which is transient relative to the unique minimal T-semiflow Y (Propositions 1 and 2). The corresponding transient system is not blocking, thus a ready transition is enabled. Firing only ready transitions, every reached marking enables a ready transition until a sequence whose Parikh vector equals Y is fired. By Proposition 6, the system is reversible.

If $S = (N, M_0)$ is well-behaved and reversible, there exists a feasible sequence σ_Y whose Parikh vector equals the minimal T-semiflow Y , such that $M_0 \xrightarrow{\sigma_Y} M_0$ (Proposition 6). Thus, for every $k \geq 1$, the sequence $\sigma_{kY} = (\sigma_Y)^k$ is feasible.

Consider a feasible sequence σ and the smallest integer k such that σ is transient relative to the T-semiflow $Y_k = k \cdot Y$ with $M_0 \xrightarrow{\sigma} M$. The confluence property (Proposition 5) states the existence of two feasible sequences α and β such that $M_0 \xrightarrow{\alpha} M_0$ and $M \xrightarrow{\beta} M_0$, satisfying, for every transition t ,

$$\begin{aligned} \vec{\alpha}(t) &= \max\{\vec{\sigma}_{kY}(t), \vec{\sigma}(t)\} & - \vec{\sigma}_{kY}(t) &= \vec{\sigma}_{kY}(t) - \vec{\sigma}_{kY}(t) = 0 \\ \vec{\beta}(t) &= \max\{\vec{\sigma}_{kY}(t), \vec{\sigma}(t)\} & - \vec{\sigma}(t) &= \vec{\sigma}_{kY}(t) - \vec{\sigma}(t). \end{aligned}$$

The feasible sequence β completes the transient sequence σ up to the T-semiflow Y_k , i.e. $\vec{\sigma} + \vec{\beta} = k \cdot Y$ and we note $M_0 \xrightarrow{\sigma, \beta} M_0$. This particular use

of confluence is illustrated in Figure 4. We deduce that the transient system (N, M, σ, Y_k) contains an enabled ready transition, hence it is not blocking. \square

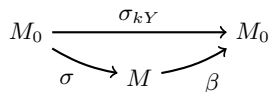

Fig. 4. If both sequences σ_{kY} and σ are feasible, then there exists a sequence β such that $\sigma.\beta$ is feasible and $\vec{\sigma}_{kY} = \vec{\sigma} + \vec{\beta}$.

The following lemma shows the existence of a blocking subsystem.

Lemma 3. *Consider a transient Choice-Free system $S = (N, M, \sigma, Y)$ that is strongly connected. If S is blocking then it contains at least one non-empty strongly connected FA P-subsystem $(N_*, M|_{P_*})$ with $N_* = (P_*, T_*, W_*)$ such that the transient system $(N_*, M|_{P_*}, \sigma|_{T_*}, Y|_{T_*})$ is blocking.*

Proof. We prove the claim by induction on the number n of join-transitions. If $n = 0$, S is an FA system and we are done. Otherwise, let t be a join-transition.

If t is ready, denote by p one of its non-enabled input places. Such a place exists since the whole system is blocking. Otherwise, t is frozen. Since S is strongly connected and blocking, thus transient, there exists in S an elementary path (*i.e.* that does not contain two occurrences of the same node) from a ready transition to t containing an input place p of t .

A new system S' is obtained by deleting all input places of t except p . Denote by R the reduced graph of S' , *i.e.* the directed acyclic graph in which every node is obtained by contracting all the nodes of a maximal strongly connected component of S' into one point and every arc (u, v) , u and v being two nodes of R , corresponds to an arc (a, b) of S' such that a belongs to u and b belongs to v . Let G be a node of R with no input. Denoting by $N_G = (P_G, T_G, W_G)$ the subnet of S' corresponding to G , we show that $G = (N_G, M|_{P_G}, \sigma|_{T_G}, Y|_{T_G})$, which is strongly connected, is a non-empty blocking P-subsystem of S .

G is a non-empty P-subsystem of S . Since S has a T-semiflow, it contains at least one place and one transition. Moreover, S is strongly connected and the only inputs of nodes that have been deleted are inputs of the transition t , which has one input after the deletion. Thus, every node of S' has at least one input *i.e.* S' is well-connected. We deduce that G contains at least one place and one transition. For every place p of G in S' , all inputs of p in S' belong to G since G has no input in R , while the unique output of p in S' belongs to G since G is strongly connected. Thus, G is a P-subsystem of S' , which is a P-subsystem of S since only places were removed. Hence G is a non-empty P-subsystem of S .

G is blocking. Consider that S is obtained from $S_0 = (N, M_0)$ by firing σ . Since G is a non-empty P-subsystem of S , $Y|_{T_G}$ is a T-semiflow of G and $\sigma|_{T_G}$ is feasible in $G_0 = ((P_G, T_G, W_G), M_0|_{P_G})$ by Lemma 1. Moreover, for every transition t of T_G , $\bar{\sigma}|_{T_G}(t) = \bar{\sigma}(t)$, thus if t is ready in S , it is ready in G . We show first that G contains a ready transition.

Suppose that G contains only frozen transitions, then consider a frozen transition t_f in G . Since S is strongly connected, an elementary path c from a ready transition t_r to t_f exists in S . This path does not exist in S' since G has no input, thus c contains a deleted input place of t . We note $c = c_1 t c_2 t_f$. The elementary path $t c_2 t_f$ exists in S' and belongs to G since G has no input in R . If t is ready, we have a contradiction. Otherwise t is frozen, and by the choice of its deleted input places, there exists an elementary path c'_1 from a ready transition t'_r to t in S' . The path $t'_r c'_1 t c_2$ belongs to G , which thus contains a ready transition, a contradiction.

We deduce that G contains at least one ready transition and $\sigma|_{T_G}$ is transient relative to $Y|_{T_G}$ in G_0 . Moreover, all the transitions of G have the same inputs in G as in S' . Thus, if t belongs to G and is ready then its input place was chosen to be non-enabled, which is the case in G . The other ready transitions of S' are not enabled either, thus no ready transition of G is enabled and G is blocking.

Finally, G is a strongly connected blocking Choice-Free P-subsystem of S that contains strictly fewer join-transitions than S . Applying the induction hypothesis on G , a non-empty strongly connected and blocking FA P-subsystem $F = ((P_*, T_*, W_*), (M|_{P_G})|_{P_*}, (\sigma|_{T_G})|_{T_*}, (Y|_{T_G})|_{T_*})$ exists in G , thus exists in S with $(M|_{P_G})|_{P_*} = M|_{P_*}$, $(\sigma|_{T_G})|_{T_*} = \sigma|_{T_*}$ and $(Y|_{T_G})|_{T_*} = Y|_{T_*}$. \square

We are now able to prove the characterization of reversibility.

Theorem 3. *Consider a strongly connected and well-behaved Choice-Free system $S = ((P, T, W), M_0)$. S is reversible if and only if each of its strongly connected FA P-subsystems $S_* = ((P_*, T_*, W_*), M_0|_{P_*})$ is reversible.*

Proof. The necessity comes from Theorem 1. We prove the sufficiency next.

If S is empty or contains a unique place or transition, then the claim is true. Hence we suppose that S has a place and a transition. Suppose that S is not reversible, then by Theorem 2 a sequence σ is feasible in S such that $M_0 \xrightarrow{\sigma} M$, leading to the blocking system $S^b = ((P, T, W), M, \sigma, Y)$, where Y is a T-semiflow of S . Besides, Lemma 3 applies and S^b contains a non-empty strongly connected blocking FA P-subsystem $S_*^b = ((P_*, T_*, W_*), M|_{P_*}, \sigma|_{T_*}, Y|_{T_*})$, obtained by firing $\sigma|_{T_*}$ in $S_* = ((P_*, T_*, W_*), M_0|_{P_*})$. By Propositions 3 and 4, S_* is well-behaved. Applying Theorem 2, S_* is not reversible. \square

3.5 A Polynomial Live and Home Marking for Choice-Free Systems

We provide the first *polynomial* live and reversible initial marking for strongly connected well-formed Choice-Free systems, extending a polynomial live marking of [18] that was improved in [19]. To achieve this construction, we use the following polynomial markings for FA and Choice-Free systems.

The set of markings M_{FA} for FA systems. Each place p of an FA system defines a marking M_p of M_{FA} satisfying $M_p(p) = \max_p$ and for all other places p' , $M_p(p') = \max_{p'} - \gcd_{p'}$.

The marking M_{CF} for Choice-Free systems. Consider a Choice-Free system having at least one join-transition. For all input places p of join-transitions, $M_{CF}(p) = \max_p$ and for all other places p' , $M_{CF}(p') = \max_{p'} - \gcd_{p'}$.

Their main behavioral properties are now recalled.

Theorem 4 ([19]). *Consider a strongly connected and well-formed Choice-Free net N . If N is not an FA, then (N, M_{CF}) is well-behaved. If N is an FA and M_* belongs to M_{FA} , then (N, M_*) is well-behaved and reversible. Moreover, in both cases, any larger initial marking also possesses these properties.*

We extend this theorem, showing the reversibility of the polynomial marking M_{CF} in well-behaved Choice-Free systems.

Theorem 5. *Consider a strongly connected and well-formed Choice-Free net N that is not an FA. The system $S = (N, M_{CF})$ is well-behaved and reversible.*

Proof. Every non-empty strongly connected FA P-subsystem $S_* = (N_*, M_*)$ of S contains at least one input of a join-transition, otherwise strong connectedness would imply the existence of a place p in S_* having an input that does not belong to S_* , contradicting the fact that S_* is a P-subsystem. Since M_* is the restriction of M_{CF} to the places of N_* , we deduce that a place p in S_* contains \max_p tokens, while all other places p' of S_* are assigned at least $\max_{p'} - \gcd_{p'}$ tokens. Thus, M_* is greater than or equal to a marking of M_{FA} and by Theorem 4, S_* is live and reversible. Applying the characterization of Theorem 3, the Choice-Free system is live and reversible. \square

3.6 Comparison With the Special Case of Weighted T-systems

T-systems form a proper subclass of Choice-Free systems. When strongly connected and well-behaved, they are covered by well-behaved circuits [5]. A characterization of reversibility for these systems is recalled next.

Theorem 6 ([5]). *If a weighted strongly connected T-system is well-behaved, then it is reversible.*

Thus, under the well-behavedness hypothesis, the reversibility of a strongly connected T-system is equivalent to that of all its strongly connected circuit P-subsystems, constituting a particular case of Theorem 3.

In the general case of Choice-Free systems, well-behavedness of the whole system ensures that of all its FA P-subsystems, which may however not be reversible. This contrast is illustrated in Figure 5.

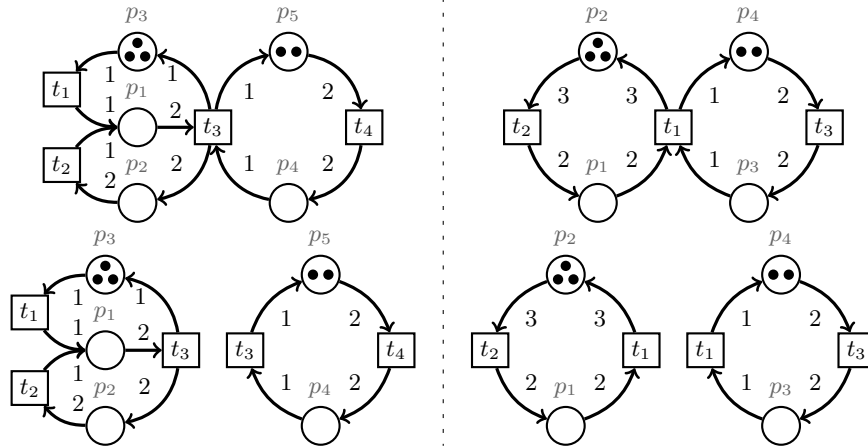

Fig. 5. On the left, the well-behaved Choice-Free system is not reversible and contains an FA P-subsystem that is well-behaved but not reversible (*bottom left*). On the right, the well-formed T-system is well-behaved and reversible, as well as all its circuit P-subsystems.

We presented two new necessary and sufficient conditions of reversibility for well-behaved strongly connected Choice-Free systems. For this class, the decomposition into FA P-subsystems induces polynomial markings that are reversible. However, these markings impose a distribution of the initial tokens over the entire system. In particular, no place is initially empty, which may cause difficulties in designing specific systems. In the next section, we develop another polynomial time sufficient condition of liveness and reversibility that provides more flexibility on the initial distribution of tokens.

4 The Place Splitting Transformation

In this section, we propose a polynomial time transformation of a strongly connected and well-formed Choice-Free system into a strongly connected and well-formed T-system with the same set of T-semiflows. We show that the liveness of this T-system is sufficient to ensure both liveness and reversibility of the initial Choice-Free system. We then derive an original polynomial time sufficient condition of liveness and reversibility for well-formed Choice-Free systems.

4.1 Definition of the Transformation

Let $S = ((P, T, W), M_0)$ be a strongly connected well-formed Choice-Free system. By Proposition 2, S has a unique minimal T-semiflow Y whose support is T . We denote by U the least common multiple of the components of Y . The system $S' = ((P', T, W'), M'_0)$ has the same set of transitions and is obtained from S as follows.

Splitting of particular places. Every place p having at least two input transitions $t_1 \dots t_k$ and an output t is replaced by k places $p_1 \dots p_k$ in P' such that, for every $i \in 1 \dots k$, p_i is an output of t_i and an input of t .

New weights. For every place p split into k places $p_1 \dots p_k$, for every $i \in 1 \dots k$, all the weights surrounding the place p_i are determined as follows:

$$W'(t_i, p_i) = U \cdot W(t_i, p)$$

$$W'(p_i, t) = W'(t_i, p_i) \cdot \frac{Y(t_i)}{Y(t)}.$$

Since the support of Y is T , the division by $Y(t) \geq 1$ is allowed. Moreover, by definition of U , $\frac{U}{Y(t)} \in \mathbb{N}$, thus $W'(p_i, t) \in \mathbb{N}$. All other weights are kept identical.

New marking. The initial marking M'_0 is computed from the marking M_0 according to:

$$M'_0(p_i) = \left\lfloor \frac{M_0(p) \cdot U \cdot W(t_i, p) \cdot Y(t_i)}{\gcd_{p_i} \cdot W(p, t) \cdot Y(t)} \right\rfloor \cdot \gcd_{p_i}.$$

This transformation is illustrated in Figure 6.

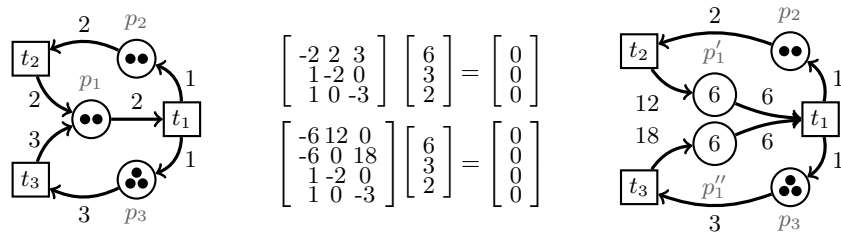

Fig. 6. The Choice-Free system on the left has the minimal T-semiflow $(6, 3, 2)$, thus $U = 6$. Applying the transformation, $W'(t_2, p'_1) = 2 \cdot 6$, $W'(t_3, p''_1) = 3 \cdot 6$, $W'(p'_1, t_1) = 3 \cdot 12/6$ and $W'(p''_1, t_1) = 2 \cdot 18/6$. The marking of p_2 and p_3 does not change. Since $\gcd_{p'_1} = 6$, $W(t_2, p_1) = 2$, $\gcd_{p''_1} = 6$ and $W(t_3, p_1) = 3$, we get $M'_0(p'_1) = M'_0(p''_1) = 6$. We obtain the T-system on the right with the same minimal T-semiflow.

4.2 Properties of the Transformation

The transformation clearly preserves strong connectedness. As shown below, it also preserves the set of T-semiflows and well-formedness.

Theorem 7 (T-semiflow preservation). *Consider the well-formed strongly connected Choice-Free system S and the transformed T-system S' . Both systems have the same set of T-semiflows and S' is well-formed.*

Proof. S and S' have the same set of transitions T . The system S , being well-formed, has a unique minimal T-semiflow Y , whose support is T (Proposition 2). For every transition t_i , $Y(t) \cdot W'(p_i, t) = Y(t_i) \cdot W'(t_i, p_i)$, thus Y is a T-semiflow of S' . We deduce that S' is consistent and strongly connected, thus well-formed (Proposition 1) and it has a unique minimal T-semiflow with support T (Proposition 2). Since Y is a T-semiflow of S' and the gcd of its components is 1, there is no smaller T-semiflow in S' , thus Y is the unique minimal T-semiflow of S' . As each T-semiflow is a multiple of Y , the set of T-semiflows is preserved. \square

This property is illustrated by Figure 6, where both systems are well-formed and have the same set of T-semiflows, including the unique minimal one.

The next property compares the number of initial tokens in both systems.

Theorem 8 (Marking bound property). *Consider a well-formed strongly connected Choice-Free system (N, M_0) and its transformation (N', M'_0) . The following inequality is satisfied for each place p transformed into k places $p_1 \dots p_k$:*

$$\sum_{i=1}^k M'_0(p_i) \leq M_0(p) \cdot U.$$

Proof. By definition of M'_0 , we obtain:

$$\begin{aligned} \sum_{i=1 \dots k} M'_0(p_i) &= \sum_{i=1 \dots k} \left\lfloor \frac{M_0(p) \cdot U \cdot W(t_i, p) \cdot Y(t_i)}{\gcd_{p_i} \cdot W(p, t) \cdot Y(t)} \right\rfloor \cdot \gcd_{p_i} \\ &\leq \sum_{i=1 \dots k} \frac{M_0(p) \cdot U \cdot W(t_i, p) \cdot Y(t_i)}{W(p, t) \cdot Y(t)} \\ &\leq \frac{U \cdot M_0(p)}{W(p, t) \cdot Y(t)} \cdot \sum_{i=1 \dots k} W(t_i, p) \cdot Y(t_i) \end{aligned}$$

Since $\sum_{i=1}^k W(t_i, p) \cdot Y(t_i) = W(p, t) \cdot Y(t)$, the claim is proved. \square

On Figure 6, $M'_0(p'_1) + M'_0(p''_1) = 12$ while $M_0(p) \cdot U = 2 \cdot 6 = 12$.

The inclusion of the language of S' in the language of S is shown below.

Theorem 9 (Language inclusion). *Every sequence that is feasible in S' is feasible in S .*

Proof. We prove the claim by induction on the size of a sequence σ that is feasible in $S' = (N', M'_0)$.

If σ is empty, then it is also feasible in $S = (N, M_0)$. Hence suppose that $\sigma = \sigma_1 t$ has size $k \geq 1$ and the property is true for σ_1 , thus σ_1 is also feasible in S . We note $M_0 \xrightarrow{\sigma_1} M_1$ and $M'_0 \xrightarrow{\sigma_1} M'_1 \xrightarrow{t} M'$.

If no input of t has been modified by the transformation, then for each of its input places p , the weights surrounding p have not been modified and the corresponding transitions have been fired the same number of times, thus $M'_1(p) = M_1(p)$ and t is enabled by M_1 in S . Otherwise, the same argument applies to any non-modified input place of t , and for every input place p of t that has been transformed into places $p_1 \dots p_k$, we show that if the places p_i , $i = 1 \dots k$, are enabled by M'_1 in S' then p is enabled by M_1 in S . It is equivalent to show that $M'(p_i) \geq 0$, $\forall i \in \{p_1, \dots, p_k\}$, implies $M(p) \geq 0$ where $M_1 \xrightarrow{t} M$. For every such place p_i , $i \in \{1, \dots, k\}$,

$$M'_0(p_i) + W'(t_i, p_i) \cdot \vec{\sigma}(t_i) - W'(p_i, t) \cdot \vec{\sigma}(t) \geq 0.$$

From the definition of W' , we get

$$M'_0(p_i) + U \cdot W(t_i, p) \cdot \vec{\sigma}(t_i) - U \cdot W(t_i, p) \cdot \frac{Y(t_i)}{Y(t)} \cdot \vec{\sigma}(t) \geq 0.$$

By summing the preceding inequality over places $p_1 \dots p_k$, we obtain

$$\sum_{i=1 \dots k} M'_0(p_i) + U \cdot \left(\sum_{i=1 \dots k} W(t_i, p) \cdot \vec{\sigma}(t_i) - \left(\sum_{i=1 \dots k} W(t_i, p) \cdot Y(t_i) \right) \cdot \frac{\vec{\sigma}(t)}{Y(t)} \right) \geq 0$$

Since $\sum_{i=1 \dots k} W(t_i, p) \cdot Y(t_i) = W(p, t) \cdot Y(t)$,

$$\sum_{i=1 \dots k} M'_0(p_i) + U \cdot \left(\sum_{i=1 \dots k} W(t_i, p) \cdot \vec{\sigma}(t_i) - W(p, t) \cdot \vec{\sigma}(t) \right) \geq 0$$

From the marking bound property (Theorem 8), it follows that

$$U \cdot \left(M_0(p) + \sum_{i=1 \dots k} W(t_i, p) \cdot \vec{\sigma}(t_i) - W(p, t) \cdot \vec{\sigma}(t) \right) \geq 0$$

thus $U \cdot (M_1(p) - W(p, t)) \geq 0$ and σ is feasible in S . \square

4.3 A Sufficient Condition of Liveness and Reversibility

We show that the transformation induces a sufficient condition of liveness and reversibility for strongly connected well-formed Choice-Free systems. For that purpose, we need the following characterization of liveness, given in [4].

Proposition 7 ([4]). *Consider a Choice-Free system $S = (N, M_0)$, its set of transitions T and the incidence matrix C of N . S is live if and only if there exist a reachable marking $M \in [M_0]$ and a sequence σ that is feasible in (N, M) such that $\vec{\sigma} \geq \mathbb{1}^{|T|}$ and $C \cdot \vec{\sigma} \geq 0$.*

We are now able to prove the sufficient condition of liveness and reversibility.

Theorem 10. *Consider a strongly connected and well-formed Choice-Free system S . Denote by S' the T-system obtained by applying the transformation to S . If S' is live, then S is live and reversible.*

Proof. Both systems have the same unique minimal T-semiflow Y and S' is well-formed (T-semiflow preservation, Theorem 7). If S' is live, then it is reversible (Theorem 6) and a sequence σ_Y , with Parikh vector equal to the minimal T-semiflow Y of both systems, is feasible in S' (Proposition 6). By the language inclusion (Theorem 9), σ_Y is also feasible in S , which is consequently live (take $M = M_0$ and $\sigma = \sigma_Y$ in Proposition 7) and reversible (Proposition 6). \square

The Sufficient Condition is Not Necessary. The liveness of the T-system is not necessary for the liveness and reversibility of the Choice-Free system, as highlighted by the counter-example on the left in Figure 7.

Comparison with the Polynomial Live and Reversible Markings. The example on the left in Figure 7 shows that the live and reversible markings of M_{FA} for FA systems are not always detected by the sufficient condition. The same holds for Choice-Free systems that are marked with M_{CF} , as pictured on the left when considering the dotted place p_4 . Moreover, there exist markings that are live and reversible without being greater than or equal to some marking of M_{FA} , while detected by the sufficient condition, as pictured on the right in Figure 7. This is also the case for the marking M_{CF} , when the dotted place p_4 is added. Thus, the set of markings detected by one method neither is included in the other set nor includes it.

4.4 A Second Polynomial Time Sufficient Condition of Reversibility

The complexity of checking the liveness of a T-system is not known. However, a non trivial *sufficient* condition of liveness has been developed in [20] for well-formed T-systems, leading to a polynomial time algorithm whose complexity is $\mathcal{O}(\max\{|P| \cdot |T|, |P| \cdot \log(\min_{p \in P} \max_p)\})$. By Theorem 10, this algorithm applies to the T-system S' issued from a well-formed Choice-Free system S to obtain a polynomial time sufficient condition of liveness and reversibility for S .

5 Conclusion

For the class of strongly connected, weighted and well-behaved Choice-Free systems, we provided a new characterization of reversibility in terms of the re-

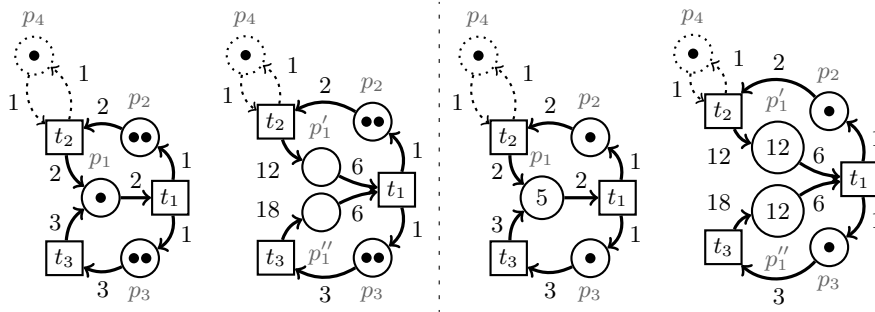

Fig. 7. On the left, the well-formed FA system (resp. Choice-Free, with the *dotted part*), marked with M_{FA} (resp. M_{CF}) hence live and reversible, is transformed into a non-live T-system. On the right, the initial marking of the FA (resp. Choice-Free) system is not greater than or equal to any in M_{FA} (resp. M_{CF}), since $\max_{p_3} - \gcd_{p_3} = 3 - 1 = 2$. However, the transformation leads to a well-behaved T-system, satisfying the sufficient condition, and the FA (resp. Choice-Free) system is live and reversible.

versibility of particular FA P-subsystems, generalizing a known liveness condition. This decomposition leads to the first polynomial time construction of live and reversible initial markings with a polynomial number of tokens, whereas prior methods were exponential. We then presented another sufficient condition of liveness and reversibility based on a polynomial time transformation into a weighted T-system. Comparing these two sufficient conditions, the set of live and reversible markings detected by one is not included in the other. Moreover, using a known polynomial time sufficient condition of liveness for T-systems, we obtained a polynomial time sufficient condition of liveness and reversibility for well-formed Choice-Free systems. Perspectives encompass extensions of these results to other weighted classes as well as applications to model-checking and to the design of embedded systems.

References

1. Lee, E.A., Messerschmitt, D.G.: Synchronous Data Flow. Proceedings of the IEEE **75**(9) (1987) 1235–1245
2. Best, E., Darondeau, P.: Petri net distributability. In Clarke, E., Virbitskaite, I., Voronkov, A., eds.: Perspectives of Systems Informatics. Volume 7162 of LNCS. Springer, Heidelberg (2012) 1–18
3. Murata, T.: Petri nets : properties, analysis and applications. Proceedings of the IEEE **77**(4) (1989) 541–580
4. Teruel, E., Colom, J.M., Silva, M.: Choice-Free Petri nets: a model for deterministic concurrent systems with bulk services and arrivals. IEEE Transactions on Systems, Man and Cybernetics, Part A **27**(1) (1997) 73–83
5. Teruel, E., Chrzastowski-Wachtel, P., Colom, J.M., Silva, M.: On weighted T-systems. In Jensen, K., ed.: Application and Theory of Petri Nets 1992. Volume 616 of LNCS. Springer, Heidelberg (1992) 348–367

6. Barkaoui, K., Petrucci, L.: Structural analysis of Workflow nets with shared resources. In van der Aalst, W.M.P., De Michelis, G., Ellis, C.A., eds.: *Proceedings of Workflow Management: Net-Based Concepts, Models, Techniques and Tools (WFM'98)*. Volume 98/7 of *Computing Science Report*. (1998) 82–95
7. Teruel, E., Silva, M.: Liveness and home states in Equal Conflict systems. In Marsan, M.A., ed.: *Application and Theory of Petri Nets 1993*. Volume 691 of *LNCS*. Springer, Heidelberg (1993) 415–432
8. Recalde, L., Teruel, E., Silva, M.: Modeling and analysis of sequential processes that cooperate through buffers. *IEEE Transactions on Robotics and Automation* **14**(2) (1998) 267–277
9. Berthelot, G., Lri-Iie: Checking properties of nets using transformations. In Rozenberg, G., ed.: *Advances in Petri Nets 1985*. Volume 222 of *LNCS*. Springer, Heidelberg (1986) 19–40
10. Berthelot, G.: Transformations and decompositions of nets. In Brauer, W., Reisig, W., Rozenberg, G., eds.: *Petri Nets: Central Models and Their Properties*. Volume 254 of *LNCS*. Springer, Heidelberg (1987) 359–376
11. Colom, J., Teruel, E., Silva, M., Haddad, S.: Structural methods. In: *Petri Nets for Systems Engineering*. Springer, Heidelberg (2003) 277–316
12. Memmi, G., Roucairol, G.: Linear algebra in net theory. In Brauer, W., ed.: *Net Theory and Applications*. Volume 84 of *LNCS*. Springer, Heidelberg (1980) 213–223
13. Sifakis, J.: Structural properties of Petri nets. In Winkowski, J., ed.: *Mathematical Foundations of Computer Science*. Volume 64 of *LNCS*. Springer, Heidelberg (1978) 474–483
14. Teruel, E., Silva, M.: Structure theory of Equal Conflict systems. *Theoretical Computer Science* **153**(1&2) (1996) 271–300
15. Keller, R.M.: A fundamental theorem of asynchronous parallel computation. In Feng, T.y., ed.: *Parallel Processing*. Volume 24 of *LNCS*. Springer, Heidelberg (1975) 102–112
16. Best, E., Darondeau, P.: Decomposition theorems for bounded persistent Petri nets. In Springer, H., ed.: *Applications and Theory of Petri Nets*. Volume 5062 of *LNCS*. (2008) 33–51
17. Lien, Y.E.: Termination Properties of Generalized Petri Nets. *SIAM Journal on Computing* **5**(2) (1976) 251–265
18. Delosme, J.M., Hujsa, T., Munier-Kordon, A.: Polynomial sufficient conditions of well-behavedness for weighted Join-Free and Choice-Free systems. In: *Proceedings of the 13th International Conference on Application of Concurrency to System Design (ACSD'13)*. (2013) 90–99
19. Hujsa, T., Delosme, J.M., Munier-Kordon, A.: Polynomial sufficient conditions of well-behavedness and home markings in subclasses of weighted Petri nets. *Transactions on Embedded Computing Systems* (2014) To appear.
20. Marchetti, O., Munier-Kordon, A.: A sufficient condition for the liveness of Weighted Event Graphs. *European Journal of Operational Research* **197**(2) (2009) 532–540