



HAL
open science

High-speed encryption method based on switched chaotic model with changeable parameters

Oleg Garasym, Ina Taralova

► **To cite this version:**

Oleg Garasym, Ina Taralova. High-speed encryption method based on switched chaotic model with changeable parameters. The International Conference for Internet Technology and Secured Transactions (ICITST-2013), Dec 2013, London, United Kingdom. pp. 41-46. hal-00996252

HAL Id: hal-00996252

<https://hal.science/hal-00996252v1>

Submitted on 26 May 2014

HAL is a multi-disciplinary open access archive for the deposit and dissemination of scientific research documents, whether they are published or not. The documents may come from teaching and research institutions in France or abroad, or from public or private research centers.

L'archive ouverte pluridisciplinaire **HAL**, est destinée au dépôt et à la diffusion de documents scientifiques de niveau recherche, publiés ou non, émanant des établissements d'enseignement et de recherche français ou étrangers, des laboratoires publics ou privés.

High-speed encryption method based on switched chaotic model with changeable parameters

Oleg Garasym

IRCCyN UMR CNRS 6597, Ecole Centrale de Nantes
Nantes, France
oleg.garasym@ircryn.ec-nantes.fr

Ina Taralova

IRCCyN UMR CNRS 6597, Ecole Centrale de Nantes
Nantes, France
ina.taralova@ircryn.ec-nantes.fr

Abstract—In this paper an improved chaotic switching algorithm based on modified Lozi system is applied. Generally speaking, the main advantage of the switched encrypted model is its robustness to the noise, while the main drawback is the slow processing speed. In this article we propose to gain model productivity by adjusting parameter in Lozi chaotic generator. Chaos generator is sensitive to any structure, therefore the solution shouldn't influence the pseudo randomness which is required for encryption. We provide the results of switched chaotic model based on Lozi chaotic generator with changeable parameter studied for chaoticity and pseudo-randomness with NIST, largest Lyapunov exponent, auto-correlation, cross-correlation and cumulative distribution.

Keywords-chaotic generator; security; encryption; switched chaotic model; NIST; Lyapunov exponent, dynamical system

I. INTRODUCTION

The current cryptographic methods of processing information aim at increasing keys length that in turn reduce the cryptographic transformations performance in terms of processing time. This is especially critical to ensure a given level resistance to the implementation in special systems and devices with existing restrictions on the amount of memory and dimensions in cases where there is no possibility to use powerful processing devices. This fact determines the importance and relevance of the search for methods to improve cryptosystem security level, robustness and speed performance.

Pseudo random number generators (PRNG) play very important cryptographic role. They are used for information encryption, to generate the encryption keys and the initialization vectors authentication requests, for the formation of a common key generating prime numbers. If PRNG is hacked, in most cases, the entire security of the system can be under threat.

Chaotic systems that generate pseudo random sequences are attracting attention, due to their complex, aperiodic and chaotic behavior and because they are sensitive to small changes in initial values and control parameters. However, using a digital system to generate chaos has many difficulties. For example, chaos is restrained by the finite precision of the system and even small errors introduced in each iteration will have a big effect on the implementation of chaos [1]. Consequently, the accumulation of the error will result in a deviation of the orbit and greatly affects the characteristics of the system. Due to the reactivity of the chaos to initial

conditions and parameters, chaotic key stream is easily affected by environmental conditions [3].

Chaotic sequences are produced by nonlinear dynamic systems that increase PRNG complexity. Nowadays many random number generators in use do not always produce sequences that are sufficiently random and usually generate very repetitive patterns, if lots of runs are required. Randomness' tests in data evaluation are used to analyze the distribution pattern of a data set. In stochastic modeling, as in some computer simulations, the expected random input data can be verified to show that tests were performed using randomized data [4]. Chaos-based PRNG is interesting application for the control theory development but always take around on open problem how to satisfy each of the requirements: robustness, security and speed performance.

II. CHAOS-BASED ENCRYPTION SCHEMES

There are three basic encryption schemes: CS (Chaotic Switching), CMI (Chaotic Mixing) and CMA (Chaotic Masking) [5]. In CS the message is encoded by switching the transmitter between two states. CMI is based on the modulation of chaotic carrier generated by the transmitter. Finally in CMA the encoding is achieved by adding the message to the chaotic transmitter output.

A. Chaotic masking (CMA)

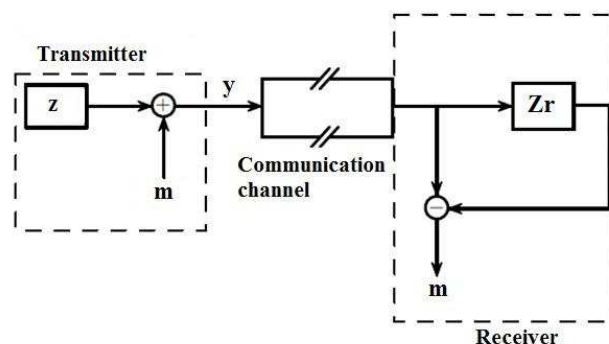

Figure 1. Chaotic masking

On the transmitting side (fig.1) information signal m is mixed to the carrier signal generated by the emitting chaotic system Z , and then transmitted over the communication channel.

The receiver Z_r is performing a full chaotic synchronization of the chaotic generator and the receiver, resulting in a dynamic host generator behavior that becomes identical to the transmission dynamics.

a) *Advantages*

This hidden communication model works quite efficiently. It allows the transmission of information to be qualitatively performed and the detection of its output in the absence of noise in the channel when the power of the signal generated by the transmitter system exceeds the power of the information signal.

b) *Disadvantages*

Adding noise to the communication channel leads to a sharp deterioration in the quality of transmitted information, requiring a high signal / noise ratio at which the scheme is working. Furthermore, the control parameters mismatch between identical chaotic generators (but located on different sides of the communication channel) also leads to additional noise at the output of desynchronization and makes information transfer difficult to fulfill. Moreover, there is the issue of confidentiality of information transfer.

B. *Chaotic mixing(CMI)*

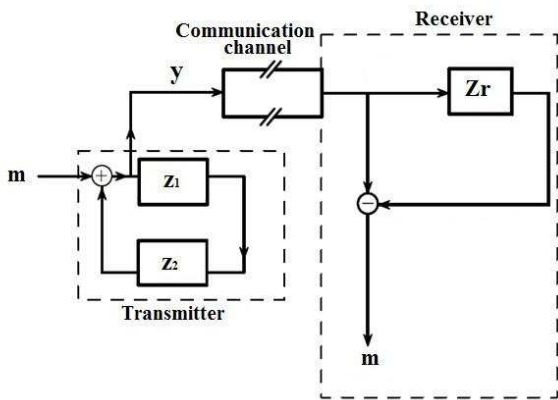

Figure 2. Nonlinear mixing of information signal to chaotic

The transmitting side contains two identical chaotic generators, z_1 and z_2 (fig.2). The information signal m is mixed with the signals produced by z_1 and output is mixed with z_2 . As a result of passing the feedback (provided by mutual generators coupling) the signal undergoes nonlinear changes. Thus, the communication channel is the transmitted signal y obtained by nonlinear mixing of information signal to the chaotic. The receiving device, as in the above scheme, contains a chaotic generator Z_r , identical to the ones in the transmitter. The receiver synchronizes the generator in case of transmission of binary bits 0 (and does not synchronize the transmission of binary bits 1).

a) *Advantages*

An important advantage of such schemes to the scheme based on chaotic masking is the ability to vary the level of the

input data message, allowing to control the quality of information transfer.

b) *Disadvantages*

Increasing the quality of communication entails a loss of confidentiality that is a significant drawback. In addition, this model is characterized by a low resistance to noise in the communication channel and mismatch control parameters of the initially identical chaotic generators. The need to ensure the identity of the three generators of chaos, two of which are located on opposite sides of the communication channel is an intractable technical problem and, therefore, is another drawback of this scheme.

C. *Switched chaotic model(CS)*

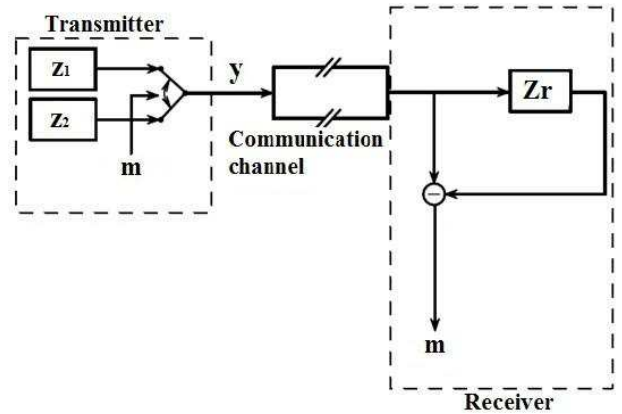

Figure 3. Switched chaotic model

The transmitting device consists of two chaotic generators z_1 and z_2 (fig.3) that may be identical (only started from different initial condition), however, in the interest of confidentiality of data transmission it is preferable to use different generators' parameters. Moreover, the signals generated by these systems must have similar spectral and statistical properties. A digital message m , represented by a sequence of binary bits 0/1, is used to switch the transmitted signal. For example the output signal from the first random generator is chosen when m is equal 0; when m is equal 1 the second switched random generator is chosen. Thus the obtained signal y is transmitted over the communication channel to the receiver Z_r . Depending on the number of generators that are on the receiving side of the channel, there are several schemes of secure communication based on chaotic switching modes.

a) *Advantages*

The switched encrypting model is more resistant to the noise in the communication channel than the chaotic masking scheme or the nonlinear signal mixing model [7].

b) *Disadvantages*

The principal drawback of this model is the occurrence of switching transients (the length of which can be quite time-consuming), that is manifested in the delay time in the synchronous mode of the receiving generator. Therefore, these schemes can be quite slow and also they have weak security [2].

III. PROBLEM STATEMENT

Hereafter we propose an improved version of switched encryption model (CS) that ensures better speed performances and robustness. The two chaotic generators Z1 and Z2 used for encryption are analyzed to setter: long-cycle length; high complexity; auto-correlation, cross-correlation near to zero; balance on [-1 1]; largest Lyapunov exponent; successful NIST test [6]. In theory there are an endless number of sequences, for Z1 or Z2 chaotic system, each realizable by changing the initial conditions. A slight difference in the initial conditions between transmitter and receiver will produce very different modulation and demodulation codes, which is an advantage of a secure chaos-based communication system.

The problem is that noise in the communication channel leads to the errors on the receiver part. Thus there is no perfect model of using chaotic generator for secure transmitting message.

The proposed model to use for secure information transmission is CS that has better resistance to the noise in the communication channel than other models. The security problem that is considered in [2] will be solved in the next paper by using CS in combination with other models.

To construct the model we consider a new Lozi alternate system with auto-coupling and ring-coupling proposed in (2011) [7] and described in [8] that has highly sufficient chaotic properties on the p-dimensional tours, $x \in \mathbb{R}^p$ $T^p = [-1, 1]^p$ by the map $M_p : T^p \Rightarrow T^p$.

$$z: \begin{cases} x_{n+1}^1 = 1 - 2|x_n^1| + k^1((1-e_1)x_n^2 + e_1x_n^1) \\ x_{n+1}^2 = 1 - 2|x_n^2| + k^2((1-e_1)x_n^3 + e_2x_n^2) \\ \vdots \\ x_{n+1}^p = 1 - 2|x_n^p| + k^p((1-e_p)x_n^p + e_px_n^p) \end{cases} \quad (1)$$

Where the parameters $k^j = (-1)^{j+1}$, and $e_p \in]0, 1[$. The graph of the map $-2|x_n^p|$ is the tent map. To avoid divergence, the following conditions have to be fulfilled.

If $x_{n+1}^j = 1 - 2|x_n^j| + k^j((1-e_j)x_n^{j+1} + e_px_n^j) < -1$ then add 2

If $x_{n+1}^j = 1 - 2|x_n^j| + k^j((1-e_j)x_n^{j+1} + e_px_n^j) > 1$ then subtract 2

However another problem with chaotic systems is autonomy and any modification in the system could lead to the loss of randomness. Hence the aim is to simplify the applied model while maintaining security and increasing work-speed.

IV. SOLVING THE PROBLEM

We suggest that instead of switching between two different generators, to change only the parameters of the same generator (structurally speaking) depending on the message bit (0 or 1). The chaotic system sensitivity allows us to slightly

change parameters in order to create generators with new dynamical properties. The question is if the new generator will have the same good characteristics of randomness and chaoticity.

We investigated the system (1) and propose to add a switching parameter a .

$$a = \begin{cases} 1, m_n = 1 \\ 0.1, m_n = 0 \end{cases}$$

where m_n is a bit of a message and equal to 1 or 0. The parameter a is added to the system (1):

$$\begin{aligned} x_{n+1}^1 &= 1 - 2|x_n^1| + ak^1((1-e_1)x_n^2 + e_1x_n^1) \\ x_{n+1}^2 &= 1 - 2|x_n^2| + ak^2((1-e_2)x_n^3 + e_2x_n^2) \\ &\vdots \\ x_{n+1}^p &= 1 - 2|x_n^p| + ak^p((1-e_p)x_n^p + e_px_n^p) \end{aligned} \quad (2)$$

If $x_{n+1}^j = 1 - 2|x_n^j| + ak^j((1-e_j)x_n^{j+1} + e_px_n^j) < -1$
then add 2

If $x_{n+1}^j = 1 - 2|x_n^j| + ak^j((1-e_j)x_n^{j+1} + e_px_n^j) > 1$
then subtract 2

where a is a parameter of the chaotic system that switches depending on a bit of a message m_n . For encrypting bit '1' of the binary message $a=1$ (Lozi system) and for bit '0' $a=0.1$ (modified Lozi system). Adding additional parameter allows to increase the size of the encryption key.

Two systems Lozi – (Z1) and modified Lozi – (Z1') with parameter $a=1$ for the first and $a=-0.1$ for the second system are compared while other parameters being the same: $p=2$ (two-dimensional system) $e_1=10 \times 10^{-10}$, $e_2=2e_1$, x_0 is a random value (fig. 4).

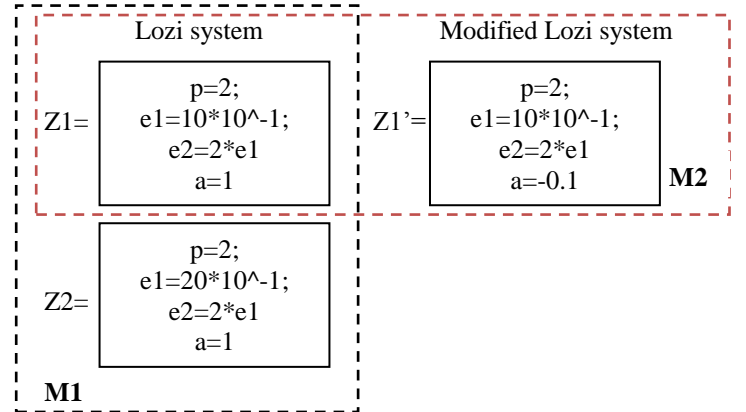

Figure 4. Transmitter parameters

The Lozi system (Z1 and Z2) is recognizable due to its lozenges after plotting where points are fall in less frequently

(fig.5). x_1, x_2 $3 \cdot 10^6$ points have been taken for the plot and the initial $2 \cdot 10^6$ points were cut off as transients.

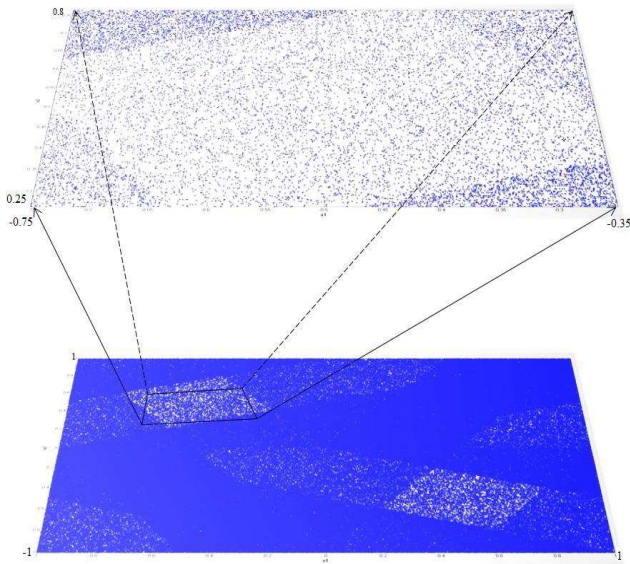

Figure 5. Lozi system phase space (x1,x2)

It was noticed that the lozenges have been removed in the modified Lozi system ($Z1'$) where $a=0.1$ (fig.6). The same plotting parameters were taken to analyze $Z1'$ system.

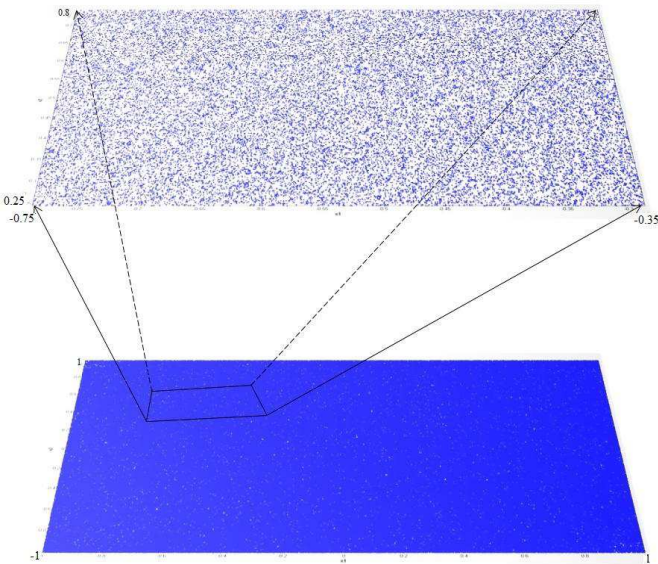

Figure 6. Modified Lozi system plotting (x1,x2) where $a=-0.1$

After 10^6 iterations the new system exhibits very few scattered empty points on the plane that implies flat distribution and chaotic behavior and the lozenges with smaller density have been removed.

After detaining system with new complex behavior we need to know if the randomness has been preserved. In addition

to confirm obtained system complexity we use largest Lyapunov exponent.

The latter is used to prove chaos existence in the system [9]. A positive largest Lyapunov exponent indicates chaos and value of this index defines the chaos degree. Lyapunov exponent characterizes the average rate of exponential divergence of close phase trajectories. If d_0 is an initial distance between two initial points of the phase trajectories in time t distance between trajectories, that go out of this points will be: $d(t)=d_0e^{\lambda t}$, where λ is called the Lyapunov exponent. Each dynamical system is characterized by spectrum Lyapunov exponent $\lambda_i (i=1,2,\dots,n)$ where n is an equation number needed for system description.

The aforementioned examination methods for randomness give the possibility to determine chaotic generators quality and security.

To check the system for chaos existence Largest Lyapunov Exponent (LLE) approach is applied by using free software package TISEAN [10]. The sequence must be saved in ASCII format and after that is called the function by `lyap_r` from matlab:

```
system([tiseanPath, 'lyap_r -s20 -o lyapunov.dat
Lozi_m.dat']);
```

The LLE for Lozi system is equal 0.6599, for modified Lozi system is 0.7232.

Another advantage of such modification is that the output systems $Z1$ and $Z1'$ (where $a=1$ and $a=-0.1$) trajectories don't converge to each other (fig.7). To plot sequences has been taken for instance interval from 500 000 to 500 100 iterations.

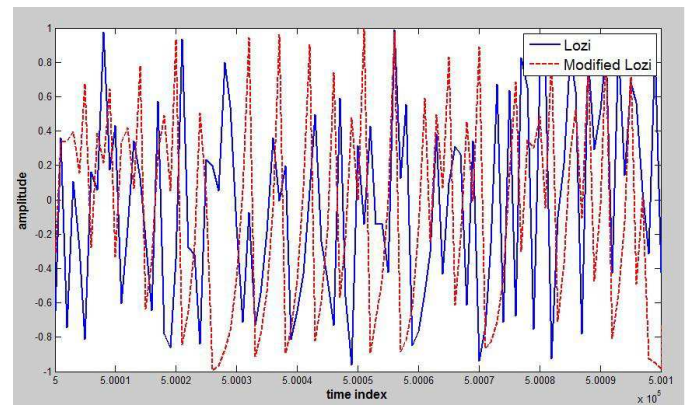

Figure 7. Trajectories of the Lozi and the modified Lozi systems don't converge to each other

Thus the appropriateness of adding switched parameter a to Lozi system is demonstrated and although modeled by deterministic map, the analyzed chaotic generator with new parameter exhibits excellent random properties.

V. RANDOMNESS TESTS FOR SWITCHED ENCRYPTING MODEL BASED ON MODIFIED LOZI SYSTEM

Randomness sequences statistical properties are displayed as graphical dependencies in appearance that drive conclusions about the sequence properties. This group consists of different set tests such as a histogram of distribution,

autocorrelation function, cross correlation function, distribution of elements on the plane that are applied to analyze M2. M2 is the switched chaotic model (fig.3) where Z1 and Z1' generators are used (fig.4).

Autocorrelation function is described as equation (3) and is used as a qualitative tool for checking randomness. The random sequence has autocorrelations near zero for any and all time-lag. If one or more of the autocorrelations strongly deviate from zero, it indicates non-randomness.

$$R_x(j) = \frac{1}{N} \sum_{i=1}^N x_i x_{i+j} \quad (3)$$

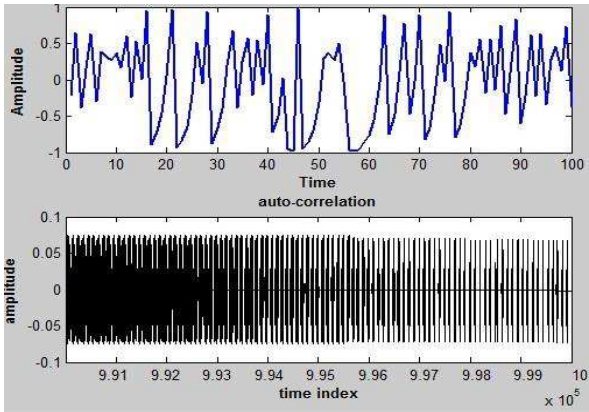

Figure 8. Autocorrelation

The cross correlation function (4) however measures the dependence of the values of one signal x_i of Z1 generator on another signal x_i' of Z1' generator.

$$R_{x_1 x_2}(j) = \frac{1}{N} \sum_{i=1}^N x_{1i} x_{2i+j} \quad (4)$$

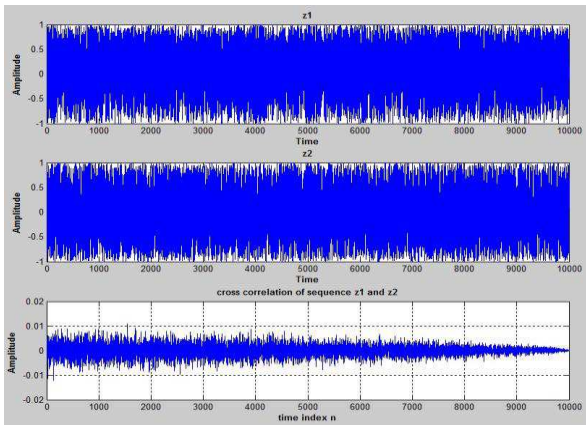

Figure 9. Cross correlation

Distribution is the secure demonstration of randomness in cryptography. This quantifier has been chosen as being more informative than the histogram. In the random case x is uniformly distributed on the interval. Distribution histograms allow us to estimate samples partition in the studied sequence, and to determine the frequency of occurrence of a specific value. For the random sequences the frequency character

should be about the same. It is demonstrated on fig.10 that M2 output sequence propagation is proportional in the interval $[-1, 1]$ where $F(y) = \text{number of output samples} \leq y / \text{total number of output samples}$ and this for all values in the output vector Y .

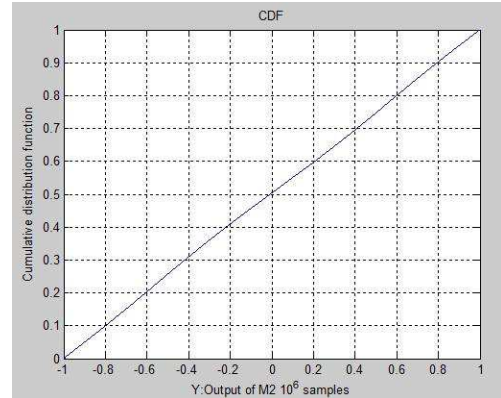

Figure 10. Cumulative distribution function (cdf), of the output of M2 (Z1-Z1')

The iteration M2' from 500 000 to 1000 000 possess such features:

- Minimum value: -1.0
- Maximum value: 1.0
- Sample mean: -1.7167e-04
- Sample median (50th percentile): -9.9044e-04
- Sample standard deviation: 0.5739

The modified Lozi system with new parameter has sufficiently good results: high complexity; auto-correlation (fig. 8) and cross-correlation (fig. 9) near to zero, normal distribution (fig. 10), balance on $\{-1, 1\}$. Thus it seems that sequences are really chaotic, but we need to perform additional tests. To verify more precisely randomness statistical NIST test and largest Lyapunov exponent are used.

VI. TWO MODELS COMPARISON

Two switched encrypting models based on Lozi and modified Lozi systems have been compared. For the first model M1 we take two generators Z1 and Z2 with different ϵ -value (fig. 4) while the other parameters are the same: $p=2$ (two-dimensional systems), x_0 is randomly chosen. For the second model M2 we take two generators Z1 and Z1' (fig. 4).

Each of the models encrypts 4 million bits of the message. To generate the message, "Bernoulli Binary Generator" block of the Simulink with 0.5 probability of a zero has been used. The initial 1 mln points were cut off as transients out of 4 mln.

NIST requires binary form values hence for efficient parsing randomness we need to make binarization of the sequences according to IEEE-754 standard for 32 bit form.

64 bit binarization has not been used because $x_i = [-1, 1]$, so that mantissa in binary form for integer part is the same and takes 11 bits information that are non-changeable and it leads to faulty verification for randomness.

31 bits for the decimal part and 1 bit for the sign according to IEEE-754 standard for 32 bit were taken. The Matlab function quantizer([32,31]) for reservation 32 cells is used, where the first bit for the sign is kept. Consequently function num2bin(q,data) makes binarization, where q – 32 ‘cells’ and data – value which we want to binarize. For example:

```
data = -0.4893
bin = 1100000101011101001111000011011
data = 0.8087
bin = 01100111100000110111101101001010
```

Where first bit is 0 when ‘data’-value is positive and 1 when – negative. After binarization of the tested systems, NIST tests have been applied.

NIST statistical tests are used as a tool to verify sequences produced by generator for randomness. For each test it received conclusion about acceptance or refusal. Each of the tests is based on calculation value test statistic that is data function. This statistics takes weighted P-value which determines if the sequence is random.

The NIST package includes 15 statistical tests, aim of which is the estimation of randomness measure for binary sequences: Frequency, BlockFrequency, CumulativeSums, Runs, LongestRun, Rank, FFT, NonOverlappingTemplate, OverlappingTemplate, Universal, ApproximateEntropy, RandomExcursions, Serial, LinearComplexity [5].

TABLE I. TWO MODELS COMPARISATION

Test Name	Two Lozi generators	Modified Lozi and Lozi generators
Frequency	100 /100	99/100
BlockFrequency	98 /100	96/100
CumulativeSums	100 /100	99/100
Runs	99 /100	100/100
LongestRun	97/100	100/100
Rank	99/100	98/100
FFT	99/100	99/100
NonOverlappingTemplate	99/100	100/100
OverlappingTemplate	98/100	98/100
Universal	98 /100	100/100
ApproximateEntropy	99 /100	99/100
RandomExcursions	63/63	66/66
RandomExcursions Variant	63/63	66/66
Serial	98/100	99/100
LinearComplexity	96/100	99/100
largest Lyapunov exponent	0.3005	0.4609
Time executing – 4mln bits	2.9866e+04	2.1755e+04

As seen in the table (1) the results of the two systems are different, that means that chaotic behavior has changed and we succeeded to obtain new sequences while maintaining randomness, what was our aim. The performances of the switched M2(Z1-Z1’) model have been studied for autocorrelations, cross-correlations, NIST tests and Lyapunov exponents.

VII. RESULTS AND FUTURE WORK TO BE UNDERTAKEN

The proposed transformation in the Lozi system allows us to switch a parameter (depending on the bit of a message) to receive quickly splitting trajectories and improved randomness. The speed of execution by classical switched two independent chaotic generators (M1) is worse. Encrypting time for 400000 bit information is 2.9866e+04 matlab’s time units, for the switched M1 model between two generators and 2.1755e+04 for the proposed model M2 with switched parameter.

We received new chaotic behavior that passed several tests better and the largest Lyapunov exponent is higher than the standard form of Lozi system. But we made studies only with one parameter and the new system should be more precisely studied. Future questions: if the system with new parameter is better or not; is it possible to increase chaoticity of the switched chaotic model; observers need to be designed for the decrypting model as well.

VIII. SUMMARY

The switching chaos-based encrypted model was achieved by using Lozi chaos system with adding switched parameter a depending on 0/1 bit of the message. The modified Lozi system was verified for randomness by auto-correlation, cross-correlation, and distribution. It successfully passed NIST tests, and largest Lyapunov exponent has been increased showing strong chaotic behavior. The execution speed has been increased. Such method offers to have larger encryption key and allows us in the future research to make different modification to improve security and robustness.

REFERENCES

- [1] F.Lau, C.Tse, “Chaos-based digital communication systems” (book) Hong Kong, China, Springer, Jun 4, 2003. - 228 p.
- [2] Yang T, Yang LB, Yang CM. Breaking chaotic switching using generalized synchronization: examples. IEEE Trans Circuits Syst I, 1998;45:1062.
- [3] Kazuyuki, A.: Chaos and Its Applications. IUTAM Symposium on 50 Years of Chaos: Applied and Theoretical (2012), pp. 199-203
- [4] National Institute of Standard and Technology “Random Number Generation and Testing”, available at <http://csrc.nist.gov/rng/>
- [5] A.A. Koronovskii, O.I. Moskalenko, A.E. Hramov. On the use of chaotic synchronization for secure communication, physical sciences journal 2009 (in russian).
- [6] Andrew D., P. Jose, 1999. “Chaotic Generation OF PN Sequences: AVLSI Implementation”, proceedings of the 1999 IEEE International Symposium on Circuits and Systems, pp:454-457.
- [7] R. Lozi , E Cherrier “Noise-resisting ciphering based on a chaotic multi-stream pseudo-random number generator”, 6th International Conference on Internet Technology and Secured Transactions, 11-14 December 2011, 1, Abu Dhabi, United Arab Emirates
- [8] Espinel, I. Taralova, R.Lozi “New alternate ring-coupled function for random number generation”, Journal of Nonlinear Systems and Applications 2012
- [9] L. D. Iasemidis, J. C. Sackellares, H. P. Zaveri, & W. J. Williams, “Phase space topography and the Lyapunov exponent of electrocorticograms in partial seizures”, Brain Topography, 2 (1990), pp. 187 – 201
- [10] R. Hegger, H. Kantz, T. Schreiber, “Practical implementation of nonlinear time series methods: The TISEAN package”, CHAOS, 9, 413, (1999)