



HAL
open science

Virtual lab based on co-simulation to include impairments of wireless telecommunication such as GSM-R in the evaluation of ERTMS

Patrick Sondi, Marion Berbineau, Mohamed Kassab, Martine Wahl, Christophe Gransart, Etienne Lemaire, G. Mariano, Mohamed Ghazel, Vincent Benard, Walter Schon

► To cite this version:

Patrick Sondi, Marion Berbineau, Mohamed Kassab, Martine Wahl, Christophe Gransart, et al.. Virtual lab based on co-simulation to include impairments of wireless telecommunication such as GSM-R in the evaluation of ERTMS. TRA - Transport Research Arena, Apr 2014, Paris, France. hal-00985733

HAL Id: hal-00985733

<https://hal.science/hal-00985733v1>

Submitted on 30 Apr 2014

HAL is a multi-disciplinary open access archive for the deposit and dissemination of scientific research documents, whether they are published or not. The documents may come from teaching and research institutions in France or abroad, or from public or private research centers.

L'archive ouverte pluridisciplinaire **HAL**, est destinée au dépôt et à la diffusion de documents scientifiques de niveau recherche, publiés ou non, émanant des établissements d'enseignement et de recherche français ou étrangers, des laboratoires publics ou privés.

Virtual lab based on co-simulation to include impairments of wireless telecommunication such as GSM-R in the evaluation of ERTMS

Patrick Sondi^{1*}, Marion Berbineau², Mohamed Kassab², Martine Wahl², Christophe Gransart², Etienne Lemaire³,
Georges Mariano³, Mohamed Ghazel³, Vincent Benard³, Walter Schön⁴

¹Laboratoire d'Informatique Signal et Image de la Côte d'Opale (LISIC), Calais, France

²Laboratoire Électronique Ondes et Signaux pour les Transports (IFSTTAR/LEOST), Villeneuve d'Ascq, France

³Évaluation des Systèmes de Transports Automatisés et de leur Sécurité (IFSTTAR/ESTAS), Villeneuve d'Ascq, France

⁴Heuristique et Diagnostic des Systèmes Complexes (HEUDIASYC), CNRS UMR7253, Compiègne, France

Abstract

The deployment of the European Rail Traffic Management System (ERTMS) is mandatory along European railway corridors, but it will follow a long and expensive process. Thus, there is a need for faster roll-out and reduction in cost for the certification and authorization necessary to put equipment into service. One of the solutions to accelerate the process relies on making intensive use of lab-testing before real deployment. The ANR VEGAS project, labeled by i-Trans will design, develop and evaluate a virtual laboratory based on co-simulation by connecting an ERTMS functional simulator with a simulator dedicated to telecommunication technologies evaluation. In this way, the co-simulation will allow evaluating the functional subsystem behavior while taking into account the impairments related to the telecommunication subsystem (radio propagation impairments such as bad radio links and cuts, electromagnetic interferences or attacks). This paper presents the ongoing work on this virtual laboratory, the preliminary results and interesting prospective work in this context.

Keywords: Co-simulation ; European Rail Traffic Management System ; European Train Control System ; GSM-R

Résumé

Le déploiement du système européen de gestion du trafic ferroviaire (ERTMS) est obligatoire sur les principales lignes européennes, mais ce processus sera long et coûteux. Dans ce contexte, il faut trouver des solutions permettant d'accélérer et de réduire les coûts liés à la certification et à la mise en service de nouveaux équipements. L'une d'elles repose sur l'utilisation de laboratoires virtuels pour évaluer les technologies avant de coûteux prototypes et tests réels sur voies. Le projet VEGAS, financé par l'ANR et labélisé par le pôle de compétitivité i-Trans, conçoit, développe et évalue un laboratoire virtuel basé sur la co-simulation. L'idée est de connecter un simulateur de la composante fonctionnelle de l'ERTMS avec un simulateur de réseau modélisant la composante télécommunication afin de réaliser des évaluations qui prennent en compte les aléas liés aux communications (mauvaise liaison radio, coupures, interférences électromagnétiques, charge sur le réseau, etc). Cet article présente les travaux en cours sur le laboratoire virtuel, les résultats préliminaires et les perspectives.

Mots-clé: Co-simulation ; ERTMS ; ETCS ; GSM-R

* Patrick Sondi, Associate Professor. Tel.: +33-321-465-867; fax: +33-321-463-669.
E-mail address: patrick.sondi@lisic.univ-littoral.fr



Nomenclature

ERTMS	European Rail Traffic Management System
ETCS	European Train Control System
OPNET	Optimum Network Performance
GSM-R	Global System for Mobile Communications-Railway
UIC	International Union of Railway
MA	Movement Authority
EOA	End Of Authority
RBC	Radio Block Center
MS	Mobile Station
BTS	Base Transceiver Station
ITS	Intelligent Transport Systems
GPRS	General Packet Radio Service
WIMAX	Worldwide Interoperability for Microwave Access
RBC	Radio Block Center
MAC/RLC	Medium Access Control/Radio Link Control
UMTS	Universal Mobile Telecommunication System
TDMA	Time Division Multiple Access
BSC	Base Station Controller
MSC	Mobile Switching Center
SS7	Signalling System 7
GMSC	Gateway Mobile Switching Center
HLR	Home Location Register
PSTN	Public Switched Telephone Network

1. Introduction

In order to harmonize the different train control systems deployed in Europe and to optimize traffic efficiency by dynamic train control, the International Union of Railways introduced the European Rail Traffic Management System (ERTMS). This system relies on two major components which are the GSM-R (GSM-Railway) subsystem that ensures wireless communications between the train and the control center, and the functional subsystem, identified as the European Train Control System (ETCS), that ensures train control by defining the signaling exchanged with the control center via the GSM-R. The deployment of ERTMS is mandatory along European railway corridors, but it will follow a long and expensive process. Thus, there is a need for faster roll-out and reduction in cost for the certification and authorization necessary to put equipment into service. One of the solutions to accelerate the process relies on making intensive use of lab-testing before real deployment.

The ANR VEGAS project, labeled by the competitive cluster i-Trans will design, develop and evaluate a virtual laboratory based on co-simulation. Indeed, while existing ERTMS simulators usually model only the behavior of the functional subsystem, this project aims at connecting an ERTMS simulator with a simulator dedicated to the evaluation of telecommunication technologies. In this way, the co-simulation will allow us evaluating the functional subsystem performance while taking into account the impairments related to the telecommunication subsystem (radio propagation impairments such as bad radio links and cuts, electromagnetic interferences or attacks and also network load).

One key target of VEGAS is to evaluate an evolution of the ERTMS telecommunication subsystem from the GSM-R towards a 4G technology such as LTE in order to prepare the future of railway communications. Such a virtual lab will allow railway industry to anticipate the consequences of various scenarios and will contribute to increase quality, reliability and safety of railway transport while maintaining a high productivity by reducing the trial costs. The originality of the VEGAS project relies on three main points. Firstly, VEGAS is the first proposal that will design a co-simulation approach in order to develop a simulation-based testbed for ERTMS evaluation. Secondly, VEGAS will be the first initiative that integrates a complete model of the telecommunication subsystem from the physical to the application layer in a platform dedicated to ERTMS evaluation. Finally, instead of building a new tool from scratch, VEGAS will rely on a validated industrial tool, the ERTMS simulator by ERSAs, and will connect it to the network simulator OPNET. After a brief presentation of the



ERTMS and related work on the evaluation of its major components in section 2, we describe our approach to co-simulation in section 3. In section 4, we present the ongoing developments in both simulators in order to realize the virtual laboratory, and section 5 concludes the paper.

2. ERTMS overview

The International Union of Railway (UIC) introduced the European Rail Traffic Management System (ERTMS) in order to harmonize the different train control systems in use in Europe and optimize the railway traffic and infrastructure usage by dynamic train control. The European Union (EU), which coordinates ERTMS development and legally and financially supports its implantation, decided that its deployment is mandatory on the major European corridors in case of new installations or of an upgrade of the train control or radio communication systems. An overview on railway signaling systems, including the description of all the components of ERTMS, is proposed by Midya & Thottappillil (2008). We will focus on two major components which are the European Train Control System (ETCS) and the radio telecommunication subsystem (GSM-R).

2.1. The ERTMS functional subsystem

The European Train Control System (ETCS) is dedicated for train signaling and control, while achieving three objectives (Levêque & De Cicco, 2008):

- Improved safety by train driving supervision: during its movement, the train receives information about running limitations (speed, distance, etc) in the form of a Movement Authority (MA) that defines a place on the track (End of Authority - EOA), which it must not pass.
- Higher performance by increasing speed and capacity: the driver obtains movement information directly through displays and follows safely the speed limitation until the EOA without look at trackside signals.
- Interoperability: contrary to trackside signaling systems based on colors depending on national rules, ETCS is the appropriate train control system for the lines belonging to different railway administrations.

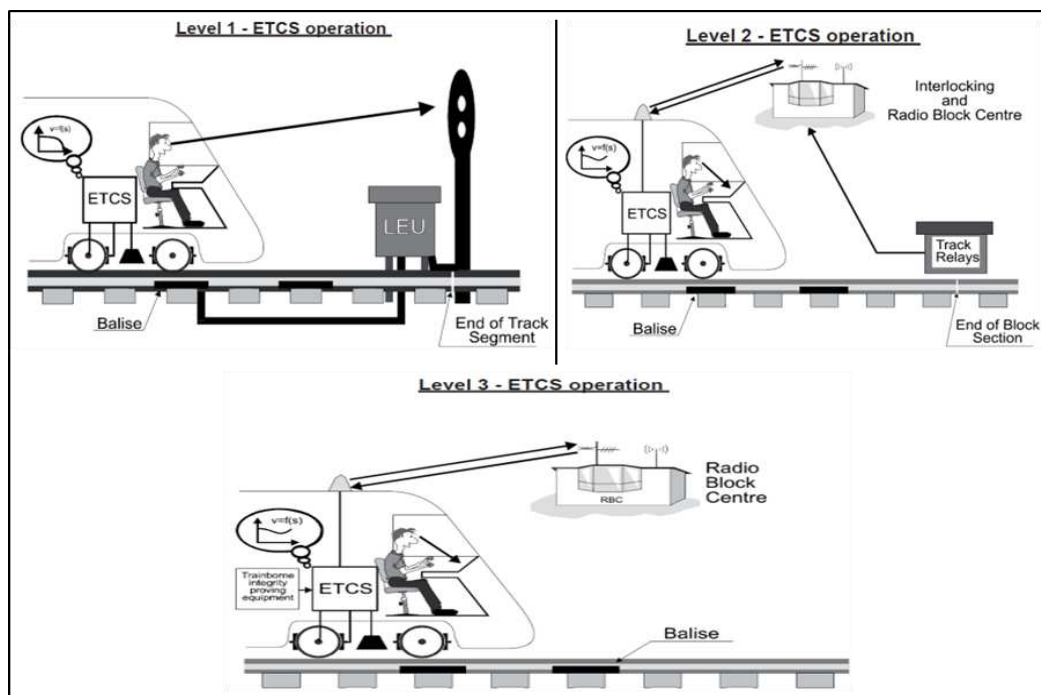

Fig. 1. ETCS operational levels (adopted from Levêque & De Cicco, 2008).

To achieve these goals progressively on the different railroads, ETCS specifications define different ETCS implementation levels for the lines in relation with trackside equipment. Among all the configurations, including those specifying the interactions with non ETCS equipment, we focus on the next three configurations (Fig. 1):



- ETCS level 1: train equipped with ETCS operating on a line equipped with Eurobalises, and optionally Euroloop or Radio in-fill to exchange messages between the train and the trackside. The train obtains its position and movement data set from the balises and it calculates the braking curves for its movement.
- ETCS level 2: train equipped with ETCS operating on a line controlled by a Radio Block Center (RBC) and equipped with Eurobalises and GSM-R. The train is permanently connected to the RBC using GSM-R infrastructure. In this way, the control center can update the information about trains movement in real-time and supervise them more dynamically. Therefore, Eurobalises mainly serve as a reference location. However, the train detection and train integrity supervision are still performed by trackside equipment.
- ETCS level 3: similar to level 2, except that the train location and the train integrity supervision are performed by onboard equipment inside the train, and no longer by trackside equipment. Eurobalises only serve as a reference location. In the future, this information could be obtained from systems such as GPS or Galileo.

The ETCS applications play a key-role in safety and efficient supervision of railway traffic. For this reason, their conception and evolution follow a stringent validation process. In this context, testbeds are particularly useful in order to perform fast and low-cost preliminary evaluations. Some simulators dedicated to ERTMS evaluation are presented in (Mera et al., 2007) and (Müller, 2003). The ERTMS simulator used in this work has been implemented following the subset 026 specifications (UNISIG, 2010), and the resulting simulation platform is compliant with the requirements for ERTMS testbeds. Though such ERTMS simulators usually include a GSM-R interface, the functioning of their telecommunication subsystem is idealized. Therefore, it is not possible to evaluate accurately the values of telecommunication-related metrics such as end-to-end delay, loss rate, network load, throughput, retransmission count per message, etc. Moreover, the impact of a dysfunction in the telecommunication subsystem on the behavior of the whole system cannot be simulated with these tools. As a result, in their current state, such simulators cannot be used in order to evaluate accurately other prospective telecommunication technologies than the GSM-R in the context of ERTMS scenarios.

2.2. The ERTMS telecommunication subsystem

The telecommunication subsystem is actually the second major component of the ERTMS. In the ERTMS level 2, its main part is currently implemented using the GSM-R (Fig. 2). This technology is based on the classical GSM architecture, but it uses specific frequency bands dedicated to railway communications. The Base Transceiver Stations (BTS) are placed every 3 to 7 kilometers along the railway in order to ensure high redundancy and to support high speeds up to 500 km/h.

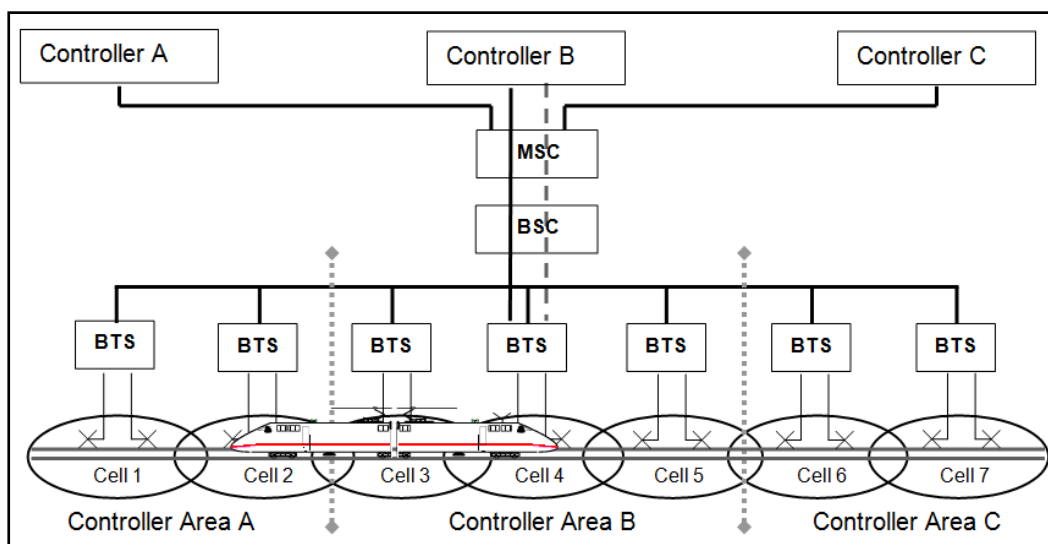

Fig. 2. GSM-R infrastructure with redundant Base Transceiver Stations in each cell.

The telecommunication subsystem plays a key-role in the ERTMS since it ensures the communications between the control center and the train for the traffic related to both the signaling and the applications. For these reasons, stringent requirements have been specified for the telecommunication technologies candidate that could be



adopted in ERTMS. Since the adoption of GSM-R, many evolutions have occurred in transportation. Indeed, the development of Intelligent Transport Systems (ITS) have brought new applications for safety and monitoring of transport systems, and also new services for customers and user-friendly applications.

In this context, the GSM-R may not still be the appropriate technology (Sniady et al, 2012; Sondi et al, 2012). In addition, mobile telephony operators in Europe have moved to 3G technologies and they are even planning to evolve towards 4G technologies such as LTE. Moreover, the industrials announced in 2009 the end of maintenance operations on GSM equipment for ending 2015 before they commit recently to ensure them until 2025. This situation will oblige railroad operators to resort to specialized services for manufacturing and maintaining GSM equipment in order to keep GSM-R operational. Consequently, GSM-R may still not be the least expensive technology for ERTMS wireless communications in a few years.

For these reasons mentioned above, several researchers have proposed to investigate other telecommunication technologies for the ERTMS, such as GPRS (Ruesche et al, 2008), WIMAX (Aguado et al, 2007) and recently LTE (Sniady et al, 2012). Some analytical and simulation based evaluations on these telecommunication technologies are proposed in the literature regarding various telecommunication metrics. However, most of the related experiments concern only the behavior of the telecommunication subsystem and are disconnected from the functional part of the ERTMS. The ETCS applications evaluated are modeled approximately in terms of the messages that they generate during the simulation scenarios, but the behavior of the functional component of ERTMS is not actually modeled in these scenarios. Consequently, it is possible to evaluate the value of the telecommunication metrics for some particular messages exchanged during the scenario, but it is not possible to actually observe the behavior of the functional component of ERTMS when a dysfunction occur in the telecommunication component simulated.

These observations emphasize the need of an evaluation tool for the ERTMS in which both the functional and the telecommunication subsystems can be simulated, and in which the impact of the behavior of one component on the functioning of the other component can be studied accurately.

3. Our co-simulation approach to ERTMS evaluation

We propose a new approach based on a co-simulation platform that will connect the ERTMS simulator with a simulator especially designed for telecommunication technologies, namely OPNET, in order to design a simulation tool dedicated to joint evaluation of both functional and telecommunication subsystems of ERTMS.

3.1. The co-simulation platform

In any ERTMS level 2 scenario, each train moves on a specific track as described in figure 2. The train sends to the control center via the RBC various information on its movement through GSM-R and it receives specific instructions (MA) by the same way. Therefore, under the assumption that all the communications occurring in the scenario between the train and the RBC meet the requirements imposed by ERTMS at the GSM-R interface, the behavior of the functional subsystem can be accurately evaluated using the ERTMS simulator.

Following the same reasoning, let us consider a scenario simulated on the ERTMS simulator where the movement (successive positions, instant velocities, etc) of the train in the time is completely stored, as well as all the sequence of the messages exchanged in the time with the RBC during this movement. Under the assumption that we are able to reproduce precisely the same movement in OPNET and the same sequence of messages following the same chronology, it is possible to obtain precisely the value of the end-to-end delay for each message exchanged. Other telecommunication related metrics can be studied in the same way. Based on these observations, we can state that an ERTMS simulation session can be regarded either:

- as a simulation of the functional subsystem based on a set of assumptions on the functioning of the telecommunication subsystem;
- as a simulation of the telecommunication subsystem where the inputs are based on a realistic functioning of the functional subsystem.

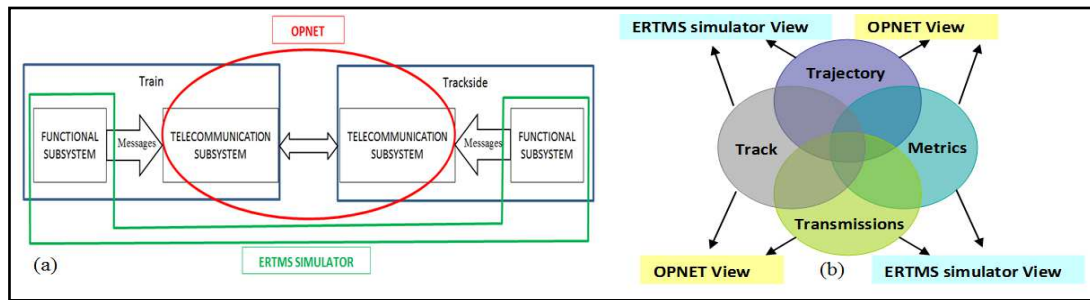

Fig. 3. Co-simulation architecture and concepts.

Following these ideas, the co-simulation platform architecture can be described as in fig. 3.a. The functional subsystem is simulated using the ERTMS simulator, and the telecommunication subsystem is simulated using OPNET. The key-elements that synchronize both simulators are the movement of the train and the messages exchanged with the control center during this movement.

3.2. Co-simulation concepts

Any ERTMS scenario can be partially modeled inside each one of both simulators in order to evaluate the related components. To ensure the coherency of each partial scenario modeled inside a simulator with the original ERTMS scenario, the following concepts are introduced:

- the **Track**: this concept represents the physical and static elements that materialize the railroad, the network infrastructure, the localization and signaling systems components. Each particular point j of a Track T_i can be fully described by a $T_{ij}=(L_{ij},P_{ij})$ where L_{ij} is its location (e.g latitude, longitude and altitude) and P_{ij} is a description of its properties (e.g color, size, type,...). The precise definitions should follow railway standards.
- The **Trajectory**: refers to the movement of one train during a specific scenario S_k on a set of Tracks $T_1, \dots, T_i, \dots, T_p$. Each step j of the Trajectory TS can be fully described by $TS_j=(T_{ij}, D_{ij}, V_{ij})$ where T_{ij} is the element of the Track T_i that the train passes at the date D_{ij} while moving with a speed V_{ij} . In this way, the movement of any train during an ERTMS scenario can be reproduced faithfully inside any of the simulators.
- The **Transmissions**: refer to the set of messages exchanged between each train and the control center during a scenario S_k . Each message j sent at a moment MS_j of the scenario S_k can be fully described either in a:
 - spatial reference domain** by $MS_j=(T_{ij}, M_j)$ where T_{ij} is the point of a Track T_i at which the message j was sent, and M_j is a full description of the message j ;
 - temporal reference domain** by $MS_j=(D_j, M_j)$ where D_j is the date at which the message j was sent in the scenario S_k , and M_j is a description of the message j ;
 - spatio-temporal reference domain** by $MS_j=(T_{ij}, D_j, M_j)$ when $TS_j.T_{ij}=MS_j.T_{ij}$ in the spatial reference domain and $TS_j.D_{ij}=MS_j.D_j$ in the temporal one. In this case, the scenario partial model is perfectly synchronized with the original scenario.

Even when a Trajectory is perfectly reproduced in both simulators, the transmission and the reception of the messages performed when the train is located between two elements of the Trajectory may not occur exactly and simultaneously at the same date and the same intermediate location in both the original scenario and the partial scenario of each simulator. For these reasons, we distinguished the spatial and the temporal domains for the Transmissions, and this will be very useful in the design of our co-simulation protocol.

- the **Metrics**: refer to the indicators that are evaluated during a scenario S_k . In an ERTMS functional simulator, one can mainly evaluate the conformity of the train behavior with the ERTMS safety specifications. In a telecommunication simulator, one can evaluate the metrics such as end-to-end delays, loss rate, handover duration, etc. For any scenario S_k , we state that:

the ordered set ES_k of the instructions given to the train by the control constitutes the Metrics for this scenario S_k in the ERTMS simulator.

the Metrics in OPNET is the set ES_k formed by the values of the metrics for each message j and that are stored in the message description M_j (e.g end-to-end delay, retransmission count), and by the values of the metrics attached to each specific element of the Track T_i located at the point h and that are stored in its properties description P_{ih} (e.g for a RBC: the number of trains connected simultaneously, lost messages per train, average queuing delay, duration of connection loss per train, etc).



When generating the partial view of an ERTMS scenario for a specific simulator, a specific view must be generated for each one of these four concepts (see Fig. 3b). According to the component evaluated by one specific simulator and the related metrics considered, the related view will contain more or less details.

3.3. Co-simulation modes

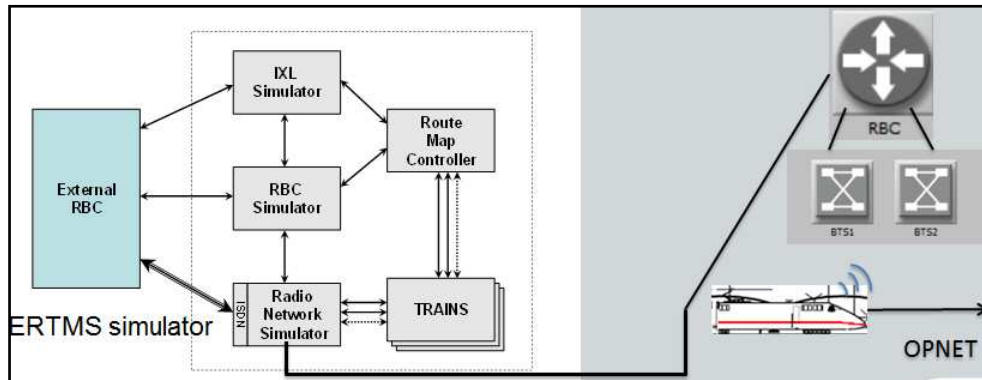

Fig. 4. Co-simulation modes: offline and online

In order to perform a co-simulation, the ERTMS simulator and OPNET can be connected in live for an online simulation or it can be done offline by replaying a scenario previously run in one simulator into the other.

Online simulation presents the advantage of running both functional and telecommunication subsystems simultaneously, thus allowing a more realistic evaluation of the entire ERTMS scenario. In this mode, the model of the telecommunication subsystem implemented in OPNET replaces the Radio Network Simulator of the ERTMS simulator (Fig. 4). The Trajectory information of the train is transmitted in live to OPNET so that the train follows the same movement in both simulators. The messages generated by the train in the ERTMS simulator go without delay through the OPNET train model where they are sent to the OPNET RBC model through BTS1 or BTS2, under realistic conditions of mobility, propagation and network transmissions. They are then routed without delay from the OPNET RBC model to the RBC Simulator inside the ERTMS simulator for functional processing. The messages generated by the RBC Simulator to the train follow the inverse process.

However, online co-simulation suits better in a context where all the models are at a release stage, and when all the problems related to the synchronization of both simulators are solved. During the development process, offline co-simulation is necessary; especially when some parts of the models are still being refined. In this mode, the scenario is first simulated with the ERTMS simulator and the information about the Track, Trajectory, Transmissions and Metrics are backed up. In this way, it is possible to check that the scenario is valid from a functional point of view. This scenario is then replayed in OPNET to evaluate the behavior of the telecommunication subsystem under realistic functional constraints. The debugging process is easier in this mode since it is possible to determine quickly which simulator is concerned with a specific error and use its built-in debugger to fix it.

3.4. Offline co-simulation protocol

Online co-simulation mode implies live exchange of data between both the ERTMS simulator and OPNET. The co-simulation process is directly under the control of the functional subsystem simulated by the ERTMS simulator which is already validated as compliant with ERTMS specification (UNISIG, 2010). Therefore, any abnormal situation occurring either due to the telecommunication subsystem or to the functional one will lead to an immediate reaction of the control system. In this way, it is obvious to validate a co-simulation and analyze the results obtained for both subsystems and for the entire system.

However, in the offline mode, a scenario previously evaluated on the ERTMS simulator is replayed in OPNET. Though we are sure that this scenario is valid from a functional point of view, while it will be running in OPNET we will have no functional warning if the telecommunication subsystem behaves abnormally. In these conditions, we need some formalized mechanisms that will allow us determining if an offline co-simulation is



valid based on the partial simulation performed in OPNET during the replay phase. We also need accurate methods that will allow us analyzing the results obtained through OPNET concerning each subsystem and the entire system.

3.4.1 Notations, assumptions and definitions

In order to describe clearly the offline co-simulation protocol that we propose to tackle these problems, we introduce the following notations and assumptions:

- We denote by $SO_n(S_k, T_k[], TS_k[], MS_k[], ES_k[])$ and $SE_n(S_k, T_k[], TS_k[], MS_k[], ES_k[])$ the n^{th} simulation session in OPNET and in ERTMS simulator, respectively, of the scenario S_k , and where:
 - $T_k[]$ is the set containing all the tracks** involved in S_k , and that can be referenced as T_1, T_2, \dots, T_p . A reference to the simulation session can be given by denoting $SO_1.S_2.T_3$ the third track used in the first simulation session in OPNET of the scenario S_2 , for example;
 - $TS_k[]$ is the ordered set of the steps encountered on the trajectory TS** during the simulation of the scenario S_k . A reference to the simulation can be given as well, for example by using the notation $SE_3.S_1.TS_6$ for the sixth step on the trajectory of the scenario S_1 during its third simulation in the ERTMS simulator
 - $MS_k[]$ is the ordered set of the messages sent during the simulation** of the scenario S_k . For example, $SO_1.S_4.MS_{1024}$ is the 1024th message sent during the first simulation of scenario 4 in OPNET;
 - $ES_k[]$ is the ordered set of the instructions received by the train** in the ERTMS simulator or the set of Metrics observed in OPNET, respectively.
- We assume that each co-simulation process of one scenario S_k must start with a valid functional view of this scenario. In other word, only $SE_0(S_k, \dots)$ exists, but not $SO_0(S_k, \dots)$.
- We assume that the $(n+1)^{th}$ simulation of a scenario S_k in one simulator depends on the simulations $SO_n(S_k, \dots)$ and $SE_n(S_k, \dots)$ of this scenario S_k . Of course, $SO_1(S_k, \dots)$ depends only on $SE_0(S_k, \dots)$ since $SO_0(S_k, \dots)$ does not exist.
- We define an equivalence relation between two successive simulations of a scenario S_k in the ERTMS simulator as follows:

$$\left((|SE_n.ES_k[]| = |SE_{(n+1)}.ES_k[]|) \text{ AND } (SE_n.ES_k[i] = SE_{(n+1)}.ES_k[i], \forall i) \right) \rightarrow (SE_n = SE_{(n+1)})$$
- When the values of all the telecommunication metrics observed on a scenario S_k during a simulation SO_n in OPNET meet the constraints imposed by ERTMS specifications on the GSM-R, we can write it as follows:

$$SO_n.ES_k \subset QOS$$

3.4.2 Offline co-simulation protocol overview

Using the notations and definitions presented in section 3.4.1, the main procedure of the protocol for offline co-simulation can be described as follows:

```

Offline_Cosimulation_Main_Procedure: Scenario  $S_k$ 
1. Consider the scenario  $S_k$ , generate a view for the ERTMS simulator and run  $SE_0(S_k, \dots)$ .
2. Based on  $SE_0(S_k, T_k, TS_k, MS_k, ES_k)$ , generate the view for OPNET and run  $SO_1(S_k, \dots)$ 
3. Based on  $SE_n(S_k, T_k, TS_k, MS_k, ES_k)$  and  $SO_{n+1}(S_k, T_k, TS_k, MS_k, ES_k)$ , generate a view for ERTMS simulator and run  $SE_{n+1}(S_k, \dots)$  /* initially  $n=0$  */
IF  $SE_{n+1} = SE_n$  THEN
  IF  $SO_{n+1} \subset QOS$  THEN STOP ON SUCCESS
  ELSE THEN
    Based on  $SE_{n+1}(S_k, T_k, TS_k, MS_k, ES_k)$ , generate OPNET view and run  $SO_{n+2}(S_k, \dots)$ 
    SET  $n=n+1$  AND GOTO STEP 3 /* The operator decides when to abandon */
  END IF
ELSE STOP ON FAIL
END IF
  
```

Fig. 5. Offline co-simulation protocol



3.4.3 Offline co-simulation validation and interpretation of the results

An offline co-simulation is currently an interactive process controlled by a human user. Yet at step 1, we get through $SE_0(S_k, T_k, TS_k, MS_k, ES_k)$ a valid simulation of the scenario S_k from a functional point of view. At step 2, we obtain through $SO_1(S_k, T_k, TS_k, MS_k, ES_k)$ the functioning of the telecommunication subsystem under a realistic functional behavior $SE_0(S_k, T_k, TS_k, MS_k, ES_k)$. Particularly $SO_1.ES_k$ provides the values of all the telecommunication metrics that were considered as of interest in the study of the considered scenario.

However, $SO_1(S_k, T_k, TS_k, MS_k, ES_k)$ may introduce some variations on the dates at which some messages are received, or cause loss of some important messages which could cause a different behavior of the functional subsystem. For this reason, the entire co-simulation can be validated only if the scenario based on $SO_1(S_k, T_k, TS_k, MS_k, ES_k)$ is valid from a functional point of view and leads to the same ordered set of instructions than $SE_0(S_k, T_k, TS_k, MS_k, ES_k)$ (step 3). In addition, if the condition $SO_1 \subset QOS$ is verified, it can be concluded that a valid co-simulation in which both functional and telecommunication subsystems meet ERTMS constraints has been performed.

In case the condition $SO_1 \subset QOS$ is not verified, the result $SE_{n+1} = SE_n$ only establishes that the co-simulation is valid. However, the telecommunication subsystem architecture needs improvement in order to meet ERTMS requirements. The operator can make the necessary improvements and repeat the co-simulation process until he gets a satisfactory configuration. When the validation test fails, this means that the scenario has changed from a functional point of view and that it makes no sense to continue iterating based on the resulting data. In this case, the co-simulation cannot be validated for the related scenario.

The mechanisms proposed in this section 3 are voluntary intuitive and constitute an attempt to formalize the description of the operations in the context of co-simulation, especially in order to evolve toward automatic operations at all levels (generation of test scenarios, evaluation by co-simulation, validation and interpretation of the results). Naturally, these mechanisms can be refined. For example, it is possible to define additional validation conditions such as the difference between the dates of transmissions of any message j in both simulators can be slightly different without exceeding a given threshold (e.g $|SE_n.S_k.MS_j - SO_n.S_k.MS_j| < \epsilon$). Other similar conditions can be specified considering spatial properties.

4. Preliminary results

The co-simulation approach proposed in this paper is part of the work dedicated to the development of a virtual laboratory for ERTMS components evaluation (VEGAS). The ERTMS simulator is a complete and operational commercial tool compliant with the specifications for ERTMS testbeds. The related models for track and scenario design and evaluation are available and ready for use, and it also supports interactions with external tools through a CORBA interface, thus allowing online co-simulation. The main remaining implementations concerning this tool are related to automatic data input in the context of an offline co-simulation, and to the integration of the telecommunication subsystem model being implemented in OPNET.

A complete model of the telecommunication subsystem, especially a model of the GSM-R in OPNET is still needed. The OPNET Modeler provides a model for the UMTS, WIMAX and LTE technologies, but not for the GSM. Several custom GSM models have been proposed for the OPNET simulator, but they all present severe limitations that impede their straightforward use in ERTMS context. One of these models is a GPRS model (Ruesche et al, 2008) that focuses on data transmission and does not implement completely GSM signaling, thus impeding the study of situation such as handover which is a critical operation in ERTMS. The physical layer of the model is also very simplified, thus impeding deep analysis of the impairments which is one of the main motivations of our work. Another custom GSM model is available in the OPNET contributed models repository. Originally designed in order to study the GSM technology from the point of view of signaling, it implements almost all the features including signaling messages, measures procedures, different handover procedures, user actions, SIM operations, interconnection with other networks and all the components of a GSM network (MS, BTS, BSC, MSC, SS7, GMSC, HLR, PSTN). However, the model misses some important features: the Link layer and the TDMA frames are not modelled, the transmission of Voice and Data are not modelled. We are currently improving this model in order to complete all the features and adapt it to obtain a GSM-R model.



We assumed that a co-simulation always start with a valid scenario from a functional point of view. It may appear that such scenario can be obtained only after a first simulation using the ERTMS simulator. However, if we consider the traces of a train that moved on real-world ERTMS level 2 lines while being controlled by ETCS, the scenario resulting from these traces is a valid scenario from a functional point of view. Considering that such a scenario is our scenario S_k , we can use it to generate the related views for both OPNET and ERTMS simulator. Therefore, it is obvious that simulating S_k using the ERTMS simulator will result in $SE_\theta(S_k, T_k, TS_k, MS_k, ES_k)$ which will be valid from a functional point of view since S_k is. As a result, provided that there exist real-world traces of ERTMS scenarios that are recognized as valid from a functional point of view and that provide sufficient information to build data input that have the same structure than $SE_\theta(S_k, T_k, TS_k, MS_k, ES_k)$, these data can be used directly to perform $SO_I(S_k, \dots)$ and obtain the behavior of the telecommunication subsystem under a realistic functioning of a valid functional ERTMS scenario. Some industrials such as ALSTOM and RFF already provide such real-world traces for research purposes. In a recent work (Sondi et al., 2013), we used the traces provided by ALSTOM in order to validate the preliminary GSM-R models developed in OPNET.

5. Conclusion

In this paper, we described the co-simulation approach that we have developed in order to design a virtual laboratory for ERTMS functional and telecommunication subsystems evaluation. The models of the GSM-R in OPNET are still being developed, and they will be evaluated using real-world traces of trains moving on ERTMS lines. In our future work, we will perform the evaluations of several ERTMS scenarios using the virtual lab, and we will introduce new models in order to evaluate other prospective technologies such as LTE.

Acknowledgements

The present research work is supported the VEGAS project (<http://vegas.ifsttar.fr>) funded by ANR (ANR-12-VPTT-0004) and labelled by i-Trans, the CISIT, the FEDER, and the Region Nord - Pas de Calais. The authors gratefully acknowledge the support of these Institutions.

References

- Aguado, M., Onandi, O., Jacob, E., Pinedo, C., Saiz, P., Higuero, M. (2007). Wimax Role on CBTC Systems. *ASME/IEEE JRCICE2007*, Pueblo, Colorado, USA.
- Levêque, O., & De Cicco, P. (2008). ETCS Implementation Handbook. UIC Infrastructure Department, 2008.
- Mera, J. M., Gomez-Rey, I., Campos, A. (2007). ERTMS/ETCS test simulation bench. *Urban Transport and the Environment in the 21st Century*, XIII, United Kingdom.
- Midya, S., & Thottappillil, R. (2008). An overview of electromagnetic compatibility challenges in European Rail Traffic Management System. *Transportation Research Part C: Emerging Technologies* 16(5), 515-534, Elsevier.
- Müller, H. K. (2003). ERTMS: on track for success. *UIC ERTMS Conference 2003*, Leipzig, UIC, 2003.
- Sniady, A., & Soler, J. (2012). An Overview of GSM-R Technology and its shortcomings. *ITS Telecommunications (ITST), 2012 12th International Conference on*, pp.626-629.
- Sondi, P., Berbineau, M., Kassab, M., Mariano, G. (2013). Generating Test Scenarios Based on Real-World Traces for ERTMS Telecommunication Subsystem Evaluation. In *Proceedings of Nets4Cars/Nets4Trains 2013*, M. Berbineau et al (Eds.), Springer-verlag, LNCS 7865, pp. 223–231.
- Sondi P., Kassab M., Berbineau M., Aguado M., Lemaire E. (2012). Toward a Common Platform for Simulation-Based Evaluation of Both Functional and Telecommunication Subsystems of the ERTMS. *JRC 2012*.
- Ruesche, S. F., Steuer, J., Jobmann, K. (2008). Increase of Efficiency in Wireless Train Control Systems (ETCS level 2) by the Use of Actual Packet-Oriented Transmission Concepts. *IEEE/ASME JRC2008*, Delaware, USA.
- UNISIG (2010). System Requirement Specification, ERTMS specifications, subset 026 v2.3.0, UNISIG.