



**HAL**  
open science

## Design and Characterization of Automated Color Sensors System

Maher Assaad, Israel Yohannes, Amine Bermak, Dominique Ginhac, Fabrice Meriaudeau

► **To cite this version:**

Maher Assaad, Israel Yohannes, Amine Bermak, Dominique Ginhac, Fabrice Meriaudeau. Design and Characterization of Automated Color Sensors System. International Journal on Smart Sensing and Intelligent Systems, 2014, 7 (1), pp.1-12. 10.21307/ijssis-2017-642 . hal-00947786

**HAL Id: hal-00947786**

**<https://hal.science/hal-00947786>**

Submitted on 17 Feb 2014

**HAL** is a multi-disciplinary open access archive for the deposit and dissemination of scientific research documents, whether they are published or not. The documents may come from teaching and research institutions in France or abroad, or from public or private research centers.

L'archive ouverte pluridisciplinaire **HAL**, est destinée au dépôt et à la diffusion de documents scientifiques de niveau recherche, publiés ou non, émanant des établissements d'enseignement et de recherche français ou étrangers, des laboratoires publics ou privés.



## DESIGN AND CHARACTERIZATION OF AUTOMATED COLOR SENSOR SYSTEM

Maher Assaad<sup>1,\*</sup>, Israel Yohannes<sup>1</sup>, Amine Bermak<sup>2</sup>, Dominique Gin hac<sup>3</sup> and, Fabrice Meriaudeau<sup>3</sup>

<sup>1</sup>*Department of Electronics and Communication Engineering, American University of Ras Alkhaimah, Ras Alkhaimah, United Arab Emirates.*

<sup>2</sup>*Department of Electronic and Computer Engineering, Hong Kong University of Science and Technology, Clear Water Bay, Kowloon, Hong Kong, SAR.*

<sup>3</sup>*Laboratoire Electronique, Informatique et Image, University of Burgundy, Dijon, France.*

Emails: maher.assaad@aurak.ae, izzrael@gmail.com, eebermak@ee.ust.hk, dominique.ginhac@u-bourgogne.fr, fabrice.meriaudeau@u-bourgogne.fr

---

**Submitted:**

**Accepted:**

**Published:**

---

**Abstract:** *The paper presents a color sensor system that can process light reflected from a surface and produce a digital output representing the color of the surface. The end-user interface circuit requires only a 3-bit pseudo flash analog-to-digital converter (ADC) in place of the conventional/typical design comprising ADC, digital signal processor and memory. For scalability and compactness, the ADC was designed such that only two comparators were required regardless of the number of color/wavelength to be identified. The complete system design has been implemented in hardware (bread board) and fully characterized. The ADC achieved less than 0.1 LSB for both INL and DNL. The experimental results also demonstrate that the color sensor system is working as intended at 20 kHz while maintaining greater than 2.5 ENOB by the ADC. This work proved the design concept and the system will be realized with integrated circuit technology in future to improve its operating frequency.*

**Index Terms:** Color sensor, light sensor, analog to digital converter (ADC), flash ADC

## I. INTRODUCTION

Color sensor systems are increasingly being used in automated applications to detect automation errors and monitor quality at the speed of production line. They are used in assembly lines to identify and classify products by color. The objectives of their usage include to check the quality of products [1-3], to facilitate sorting and packaging [4-6], to assess the equality of products in storage [7, 8], and to monitor waste products [9]. Consequently, there is abundant of color sensors and the choice is often application-driven [22, 23]. Low cost and simple color sensors are preferred over sophisticated solutions for less demanding applications where the top priority is cost and power consumption. This paper presents such a sensor that is based on an embedded analog-to-digital converter (ADC) as the end-user interface circuit. The proposed system is capable of differentiating up to eight different colors and thus, it is specifically targeted for automated applications where few colored products need to be detected.

The principle of detection embedded in our color sensor system is based on reflectance property of a colored surface, as illustrated in Figure 1. When a white light is shined on a surface, the surface will reflect a specific spectrum while absorbing all the other spectra. For example, a white light focused onto a red surface is reflected as red. The reflected red light impinges on the light transducer producing a corresponding output voltage that is typical of the reflected red color. By interpreting this output voltage using an interface circuit, the color can be determined.

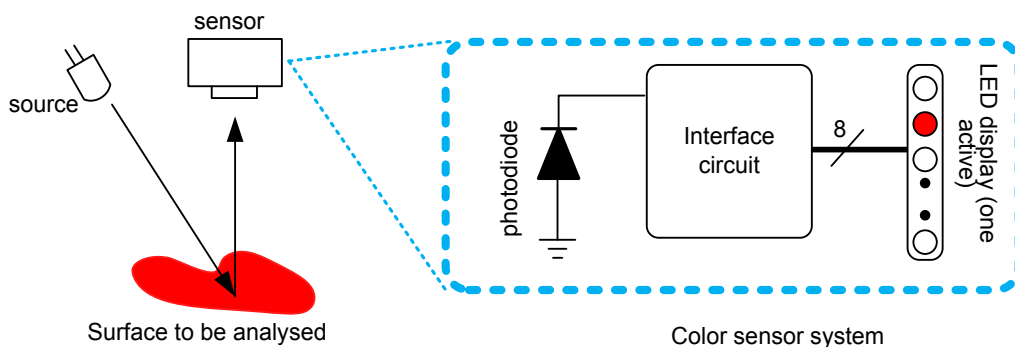

Figure 1. Surface color detection principle based on reflectance.

The success of a color sensor by reflection depends on the detector, the illuminant (light source) and the target object. Black and white objects reflect respectively 0 and 100% of the incident light falling on them while other colors reflect selected parts in the visible spectra.

Rough, glossy or dirty surfaces make the detection rather complicated since their reflectance property is different, and the source of light affects the color saturation of the object being detected [10]. For our system, the most appropriate source is a nearly pure white light (i.e. D65 daylight).

The detector of the color sensor system also plays a crucial role for efficient color recognition. A photodiode is used in the proposed color sensor system as the principal detector element. Photodiodes generate electron and hole carriers upon exposure from visible light inducing photocurrent. The maximum photo-current can be given by (1.1) [11, 12]:

$$I_{ph} = (1 - R) * (1 - e^{-\alpha*d}) * q * \frac{P_{in}}{h * \nu} \quad (1.1)$$

where  $R$  is the surface reflectivity of the photodiode;  $d$  is depth from the silicon surface;  $\alpha$  is the absorption coefficient which is dependent on the material property (e.g. silicon or GaAs);  $q$  is electron charge;  $P_{in}$  is the power of incident light;  $h$  is Planck's constant ; and  $\nu$  is the frequency of incident light. The following sections present the system design, the operating principle and the characterization of our color sensor system.

## II. COLOR SENSOR SYSTEM DESIGN

The proposed color sensor system incorporates a detector and a dedicated interface circuit. The interface circuit offers a lower cost and power consumption solution, compared with the conventional design. As depicted in Figure 2(a), conventional color sensor systems comprise (i) a light transducer, (ii) a pre-amplifying block to amplify the sensor signal and/or convert the signal from current to voltage domain, (iii) an ADC, (iv) a digital signal processor (DSP) for color recognition which may include a memory, digital comparator arrays, arithmetic units and so on to produce the final color output. In our design, we minimize the component count by storing the color table (mapping between color and photodiode output voltage) with variable resistors acting as analog memory, and generate digital color code using an embedded ADC (refer to Figure 2(b)) eliminating the need for further processing components.

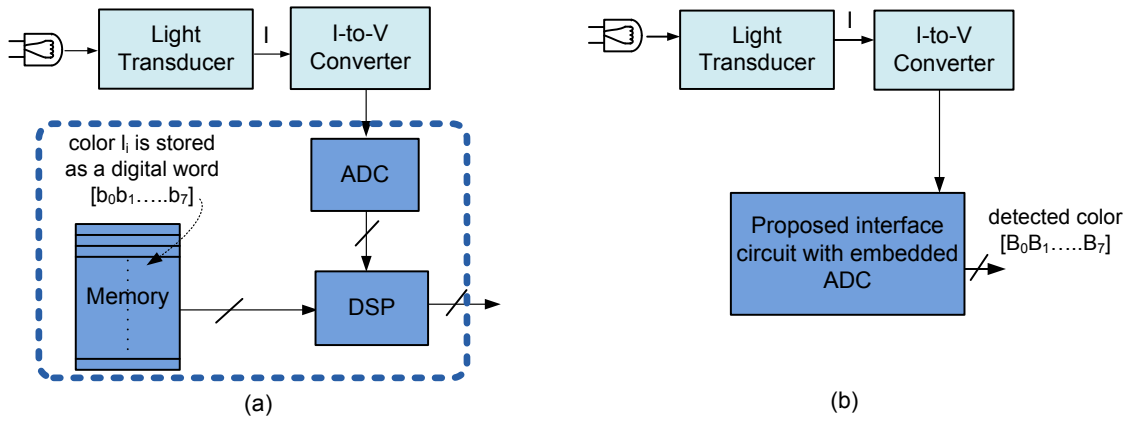

Figure 2. Block diagram of (a) conventional color detection scheme (b) color detection using the proposed color sensor system.

#### a. Transducer

The complete block diagram of the proposed color sensor system is shown in Figure 3. It comprises of a monolithic device OPT301 [13], an opto-electronic integrated circuit containing a light sensing element (photodiode) and a transimpedance amplifier on a monolithic device. The responsivity of the photodiode is dependent on the wavelength and the radiant power of the incident light falling on it. The photovoltage versus wavelength response normalized with the incident power is shown in Fig 3(a). The gain response is adjustable by using the feedback resistor  $R_F$  such that the output photovoltage is the product of the photocurrent ( $I_{phd}$ ) and  $R_F$  ( $V_{phd} = I_{phd} * R_F$ ).

#### b. Interface Circuit

The interface circuit is based on a pseudo flash ADC (shown in Fig 3(b)) that has been customized to meet the requirements of the targeted application. Indeed, the selection of a specific ADC architecture is always driven by design requirements. For high-speed, low-resolution applications, the flash architecture is a promising approach [14]; for applications such as sensor networks that do not require high speed and can tolerate data latency but have ultra-low power requirements, successive approximation (SAR) ADCs are usually used [15, 16]. Often designers combine features of one or more architectures to achieve the desired performance. The ADC designed in this work offers a balance between power consumption and speed by combining features of a flash and a digital ramp ADC. The interface circuit

needs two comparators only, regardless of the number of colors,  $N_{\text{color}}$ , to be identified. This minimizes the power as well as the on-chip area, especially when  $N_{\text{color}}$  is large.

The proposed design uses a set of tunable resistors, which form part of the ADC to store the color table. This is easily achieved as the photodiode displays a monotonous response  $V_{\text{phd}}$  to different wavelength/color. If the full scale of the ADC is 2 V, we could thus map different voltage intervals for different colors as shown in Table 1. These intervals can be easily adjusted based on calibration result from the photodiode. The proposed design uses eight indicator blinking LEDs as a simple yet clear means to indicate the final output for user through a 3-to-8 decoder where each LED represents one color/voltage interval.

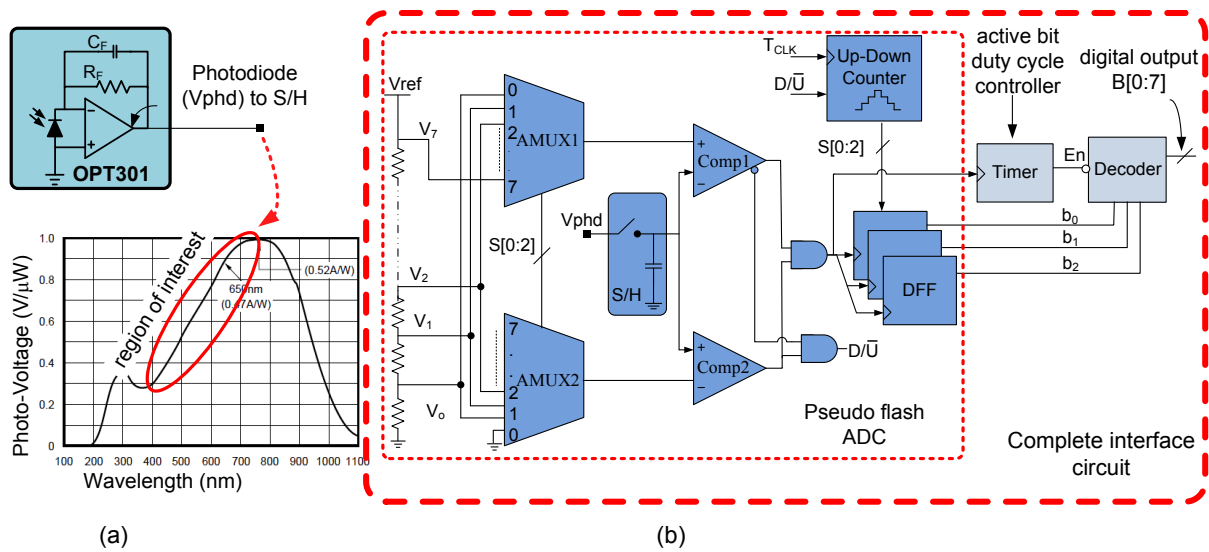

Figure 3. Proposed color sensor system (a) OPT301 photodiode and its gain adjustable photo-voltage response. (b) Interface circuit of the color sensor.

Table 1: Reference voltage intervals and their corresponding color values

Color	Designation	Voltage intervals
Violet	B0	0.00 – 0.25
Indigo	B1	0.25 – 0.50
Blue	B2	0.50 – 0.75
Green	B3	0.75 – 1.00
Yellow-Green	B4	1.00 – 1.25
Yellow	B5	1.25 – 1.50
Orange	B6	1.50 – 1.75
Red	B7	1.75 – 2.00

The timer block serves the function of adjusting the duty cycle of the LED blinking. In the case of fast color change, the timer holds the output for longer time so that the output is visually distinguished by a user. Otherwise for constant outputs, the timer limits the duty cycle so the LEDs does not draw current continuously there by lowering the power dissipation. The design also incorporates a sampler after the photodetector to ensure dynamic (time varying) color detection with minimum error.

### III. OPERATING PRINCIPLE OF THE INTERFACE CIRCUIT

The operating principle of the proposed design is depicted in the conceptual diagram Figure 4. The two analog multiplexers switch through the reference voltages creating a closed interval dynamic voltage reference. The comparators compare the photodiode response  $V_{phd}$  with the moving reference (signals  $AMUX1$  and  $AMUX2$ ) until the correct interval is found ( $V_3$  and  $V_4$  in Fig 4(b)). Then the comparators will fire simultaneously as can be seen in Figure 4(b). At this point, the counter state is registered and outputs the corresponding digital code. This code is kept in the display until a new color is detected.

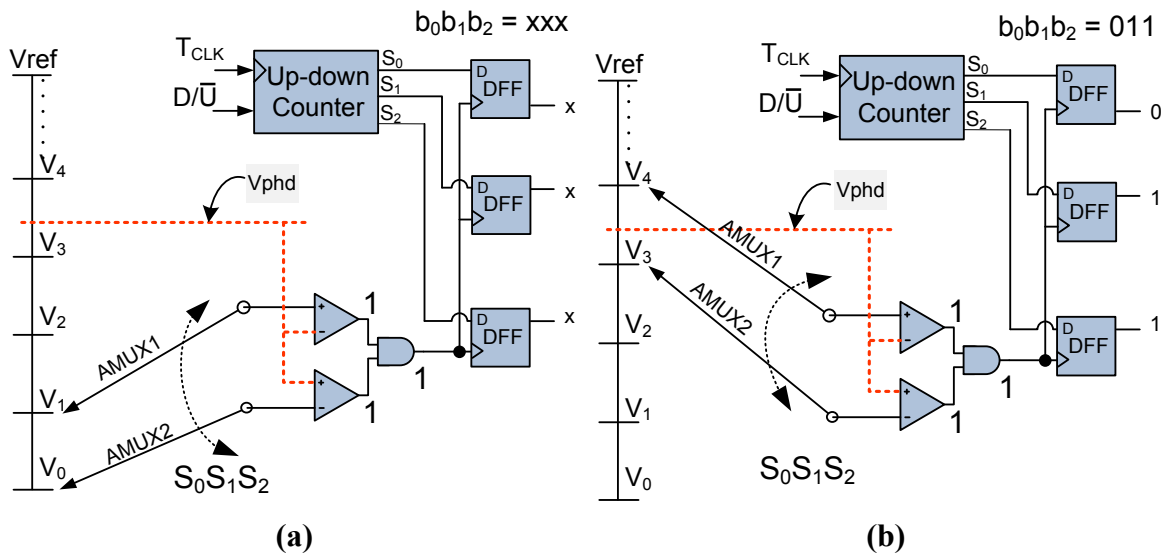

Figure 4. Conceptual diagram illustrating operation of the embedded ADC. (a) The AMUX's switch through the ladder voltage until both comparators fire, during this time the output is not updated from previous detection. (b) Both comparators fire indicating conversion process is completed.

The multiplexers are controlled by an up-down counter, which in turn is controlled by the comparison result ( $D/\bar{U}$ ). Compared with using one-sided regular counter, the proposed search scheme provides a faster conversion speed with a small hardware overhead.

As mentioned, the key advantage of the proposed system is the minimization of components count in the interface circuit which is the number of comparators being fixed to two, regardless of the number of detectable colors, as opposed to the  $2^N-1$  comparators in a conventional flash ADC, albeit with some trade-off in conversion speed. For the present 3-bit implementation, the average sampling speed of the interface circuit  $\tau_s$ , without the timer effect, is estimated to be 4 clock cycles; in the worst case condition where the AMUXs have to switch through all reference levels to reach the desired interval,  $\tau_s$  is 8 clock cycles; in the best case where the desired interval is found on its first search,  $\tau_s$  is one clock cycle. The average sampling rate can then be estimated as half the maximum rate. One clock cycle ( $\tau_{clk}$ ) can be measured based on the propagation delay of the constituent ICs, in this case  $1/\tau_{clk} = 2.8$  MHz. This gives  $1/\tau_s$ , a sampling rate of 700 kHz for the interface circuit,

$$\tau_{clk} \geq \delta_{pd} = \delta_{COUNTER} + \delta_{MUX} + \delta_{COMP} + \delta_{AND} + \delta_{DFF} \quad (1.2)$$

$$\tau_{clk} \leq \tau_s \leq 8 * \tau_{clk} \quad (1.3)$$

$$(\tau_s)_{avg.} = 0.5 * (\tau_{clk})_{MAX} = 4\tau_{clk} \quad (1.4)$$

where,  $\delta_{pd}$  is the total propagation delay and  $\delta_{counter}$ ,  $\delta_{MUX}$ ,  $\delta_{AND}$ ,  $\delta_{DFF}$  are the propagation delay of counter, AMUX, comparator, AND gate and D flip flop (DFF) respectively. As mentioned previously, the stored voltages using the variable resistors represent color voltages, which are calibrated to the sensor system before measurement begins.

#### IV. EXPERIMENT RESULTS

The proposed color sensor system has been implemented using discrete components for a quick proof of design concept. Validation was carried out by characterizing the embedded ADC then the complete color sensor system. Experimental setup for a quick proof of concept implementation on a project board is shown in Figure 5.



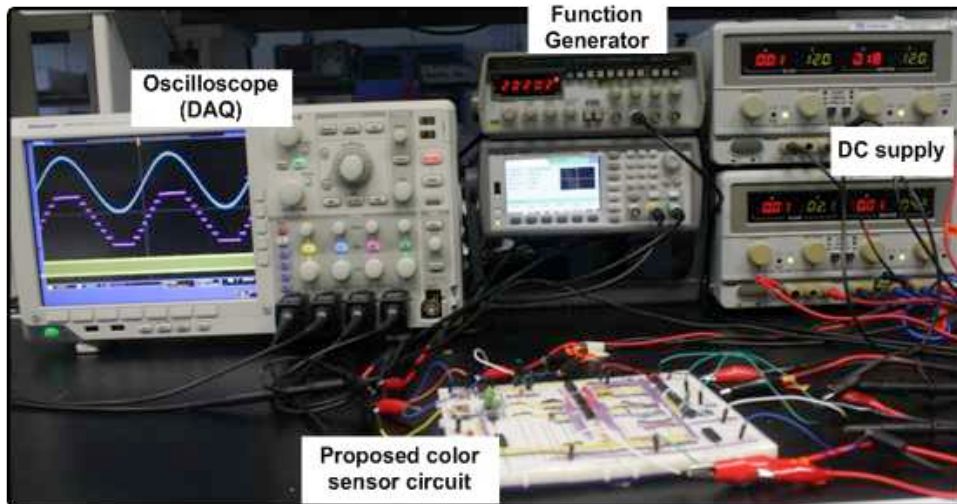

Figure 5. Experimental setup to test the proposed color sensor

#### a. Interface Circuit Characterization

The principal element of the interface circuit, the pseudo Flash ADC, was realized for a full-scale voltage of 2 V. The typical static and dynamic performance of the ADC is plotted in Figure 6. The plots show that the static characteristic of the ADC is good, achieving 0.1 LSB for both INL and DNL. In addition, regarding the dynamic characteristics, it achieved more than 2.5 ENOB at 20 kHz input frequency (input color change) on a project board.

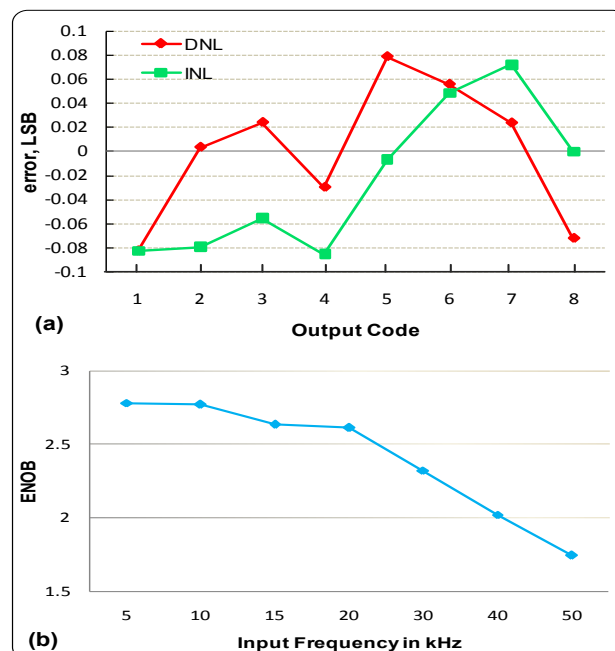
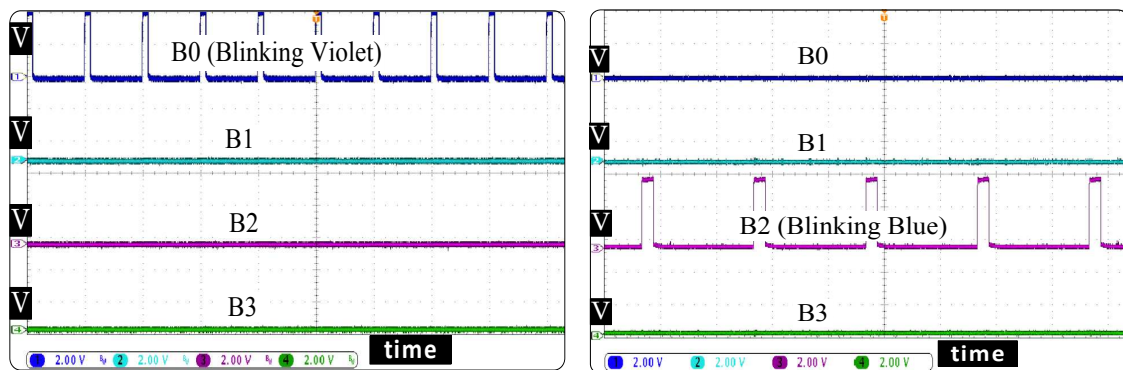

Figure 6. Embedded ADC characteristics in proposed interface circuit. (a) Differential and integral nonlinearity errors. (b) Effective number of bits against input frequency (in kHz). The interface circuit is running at  $1/\tau_s = 700$  kHz.

## b. Color Sensor System Characterization

Experiment results from the complete color sensor system, i.e. the digital outputs for different detected colors, as captured from the TDS oscilloscope are shown in Figure 7. The TDS oscilloscope has only 4 channels, hence 4 out of the 8 (output code: B0 to B7) decoded bits are shown at a time. Each bit is connected to one LED, i.e. B0 represents violet, B1 indigo, B2 blue, B3 green, B4 yellow-green, B5 yellow, B6 orange, and B7 red color respectively. As illustrated, the duty cycle of the output can be varied by using the timer in order to reduce the power drawn by the LEDs and also ensure minimum time for output to be discerned by user.



(a) B0 = 1, color violet detected.

(b) B2 = 1, color blue detected.

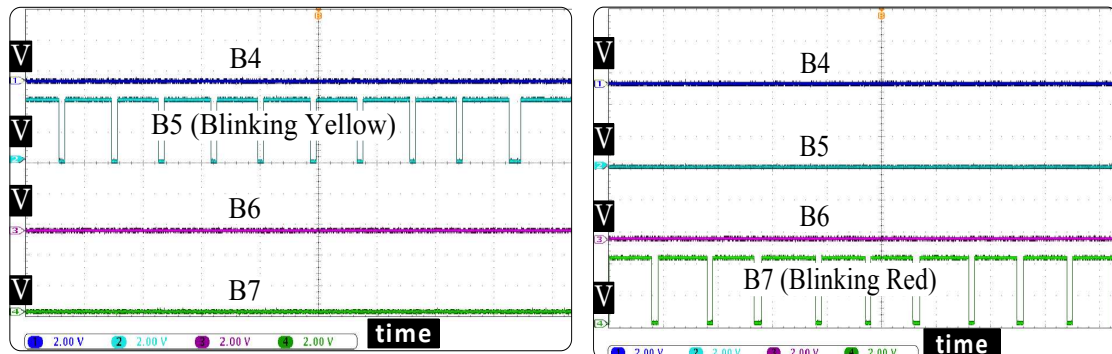

(c) B5 = 1, color yellow detected.

(d) B7 = 1, color red detected.

Figure 7. Experimental result from the proposed sensor system. The output bits and their corresponding color is shown. (Only four bits are shown at a time from a 4-channel oscilloscope).

## V. DISCUSSION

In our previous work [17, 18], we have proposed color sensor based on similar color detection mechanism. This work includes significant improvements over the previous such as (i) it uses two-sided counter (up/down) instead on one sided which contributed to improved efficiency and speed of conversion (ii) it enables dynamic (online) detection by incorporating a sampler after the light transducer unit (iii) it implements output control by regulating duty cycle using timer, which attributes to saving power. ADC characterization result of the interface circuit is also included. The core design concept about the proposed color sensor system is low component-count and scalability. While the design has been implemented for 3-bit (8 different colors), it can easily be extended to detect more than eight different colors. Apart from being low component count and low power consumption, the advantage of the proposed system is its ability to generate a digital output/code representing directly the detected color. This ensures a straightforward computation and eliminates the need of further data processing. This is desirable for easy and fast integration with subsequent units in the production line. The proposed system can be applied for assembly lines where products need to be sorted by color or colored mark. Experimental results show that the system is working as intended. For a successful detection, careful manual calibration of the voltage intervals is required before use. Future work includes integrating a dedicated CMOS photodiodes that suitable for color sensing as in [19-21] along with the proposed interface circuit on a single chip and introducing auto calibration mechanism.

## VI. CONCLUSION

A new, automated color sensor system based on an embedded 3-bit pseudo flash ADC has been realized and successful experimental results of the sensor system and the interface circuit is presented. Admittedly, the operating frequency (successful color detection rate) of the complete system is rather low, i.e. goes up to 20 kHz for  $> 2.5$  effective number of bits, which is mainly attributed to its current implementation as discrete components; however it can be significantly improved by using integrated circuit technology (i.e. much lower gate propagation delay). The proposed color sensor system design is low-cost, has low component count and simple yet scalable for higher resolution. We envisage it to be applied in automated color detection applications such as color sorting and matching applications.

## REFERENCES

- [1] C. Zhang and K. S. Suslick, "Colorimetric sensor array for soft drink analysis," *J. Agric. Food Chem.*, vol. 55, pp. 237-242, 2007.
- [2] P. D. Oram and J. Strine, "Color measurement of a solid active pharmaceutical ingredient as an aid to identifying key process parameters," *J. Pharm. Biomed. Anal.*, vol. 40, pp. 1021-1024, 2006.
- [3] M. Frank, *et al.*, "High-speed industrial color and position sensors," *Electronic Imaging'99*, pp. 50-57, 1999.
- [4] A. Pacquit, *et al.*, "Development of a smart packaging for the monitoring of fish spoilage," *Food Chem.*, vol. 102, pp. 466-470, 2007.
- [5] E. J. Cadieux Jr, *et al.*, "System and method for visually inspecting a cigarette packaging process," ed: Google Patents, 2002.
- [6] D.-J. Lee and R. S. Anbalagan, "High-speed automated color-sorting vision system," in *Optical Engineering Midwest'95*, pp. 573-579, 1995.
- [7] J. V. Popov-Raljić, *et al.*, "Investigations of bread production with postponed staling applying instrumental measurements of bread crumb color," *Sensors*, vol. 9, pp. 8613-8623, 2009.
- [8] J. V. Popov-Raljić and J. G. Laličić-Petronijević, "Sensory properties and color measurements of dietary chocolates with different compositions during storage for up to 360 days," *Sensors*, vol. 9, pp. 1996-2016, 2009.
- [9] R. Bogue, "Optical chemical sensors for industrial applications," *Sensor Review.*, vol. 27, pp. 86-90, 2007.
- [10] R. Baribeau, *et al.*, "Color reflectance modeling using a polychromatic laser range sensor," *IEEE T Pattern. Anal.*, vol. 14, pp. 263-269, 1992.
- [11] B. V. Zeghbrock, "p-n Junctions," *Principles of Semiconductor Devices*, ed: <http://ecee.colorado.edu/~bart/book/>, 2011.
- [12] M. J. Deen and P. K. Basu, "Silicon Photodetectors," *Silicon Photonics*, ed: John Wiley & Sons, Ltd, 2012, pp. 197-247.
- [13] H. L. L. Ling, "Integrated Photodiode and Amplifier OPT301," *International Electronic Elements*, vol. 12, p. 017, 2002.
- [14] G. Torfs, *et al.*, "Low-power 4-bit flash analogue to digital converter for ranging applications," *Electronics letters*, vol. 47, pp. 20-22, 2011.

- [15] S.-K. Lee, *et al.*, "A 21 fJ/conversion-step 100 kS/s 10-bit ADC with a low-noise time-domain comparator for low-power sensor interface," *IEEE J Solid-State Circuits*, vol. 46, pp. 651-659, 2011.
- [16] M. D. Scott, *et al.*, "An ultra-low power ADC for distributed sensor networks," *ESSCIRC 2002*, pp. 255-258, Florence, Italy, 2002.
- [17] M. Assaad, *et al.*, "Two-Stage Interface Circuit Design for a 32-Color Resolution Optical Sensor," *IEEE Sensors Journal*, vol. 13, pp. 610-617, 2013.
- [18] M. Assaad and I. Yohannes, "Design and characterization of multi-color sensor circuit," *IEICE Electronics Express*, vol. 8, pp. 2093-2099, 2011.
- [19] X. Fang, *et al.*, "Colorimetric porous photonic bandgap sensors with integrated CMOS color detectors," *IEEE Sensors Journal*, vol. 6, pp. 661-667, 2006.
- [20] A. Longoni, *et al.*, "The transverse field detector (TFD): A novel color-sensitive CMOS device," *IEEE Electronic Device Letters*, vol. 29, pp. 1306-1308, 2008.
- [21] P. Catrysse, *et al.*, "An integrated color pixel in 0.18 $\mu$ m CMOS technology," *Electron Devices Meeting, 2001. IEDM'01. Technical Digest. International*, pp. 24.4. 1-24.4. 4., 2001.
- [22] H. Escid, *et al.*, "0.35 mm CMOS optical sensor for an integrated transimpedance circuit," *the International Journal on Smart Sensing and Intelligent Systems*, vol. 4, no. 3, pp. 467-481, September 2011.
- [23] K. Ogawa, *et al.*, "optical probe current sensor module using the Kerr effect of exchange-coupled magnetic film and its application to IGBT switching current measurements," *the International Journal on Smart Sensing and Intelligent Systems* , vol. 5, no. 2, pp. 347-361, June 2012.