



HAL
open science

An Online Trajectory Generator-Based Impedance Control For Co-manipulation Tasks

Sarra Jlassi, Sami Tliba, Yacine Chitour

► **To cite this version:**

Sarra Jlassi, Sami Tliba, Yacine Chitour. An Online Trajectory Generator-Based Impedance Control For Co-manipulation Tasks. IEEE Haptics Symposium (HAPTICS), Feb 2014, Houston, Texas, United States. pp.391–396, 10.1109/haptics.2014.6775487 . hal-00911088v3

HAL Id: hal-00911088

<https://hal.science/hal-00911088v3>

Submitted on 27 Mar 2014

HAL is a multi-disciplinary open access archive for the deposit and dissemination of scientific research documents, whether they are published or not. The documents may come from teaching and research institutions in France or abroad, or from public or private research centers.

L'archive ouverte pluridisciplinaire **HAL**, est destinée au dépôt et à la diffusion de documents scientifiques de niveau recherche, publiés ou non, émanant des établissements d'enseignement et de recherche français ou étrangers, des laboratoires publics ou privés.

An Online Trajectory Generator-Based Impedance Control For Co-manipulation Tasks

Authors: *Sarra Jlassi, Sami Tliba and Yacine Chitour*

S. Jlassi, S. Tliba and Y. Chitour are with Laboratoire des Signaux et Systèmes UMR8506, Univ Paris-Sud, CNRS, SUPELEC, 3 rue Joliot Curie, 91192 Gif-sur-Yvette, France (corresponding author e-mail: sami.tliba@lss.supelec.fr).

Université Paris-Sud XI,
U.F.R. des Sciences d'Orsay
Layout by Sami TLIBA, © September 2013

UMR : Laboratoire des Signaux & Systèmes
Projet : Robotic comanipulation
Type : Preprint to "2014 IEEE HAPTICS Symposium"

Abstract

This paper addresses the problem of heavy load co-manipulation in the context of physical human-robot interactions (PHRI). During PHRI, the resulting motion should be truly intuitive and should not restrict in any way the operator's will to move the robot such he would like. The idea proposed in this paper consists in considering the PHRI problem for handling tasks as a constrained optimal control problem. For this purpose, we have designed a new modified impedance control method named *Online Trajectory generator-Based Impedance (OTBI) Control*. This method relies on the implementation of a specific event controlled online trajectory generator (OTG) interconnected to a classical structure of impedance control allowing a good tracking of the generated trajectory. This OTG is designed so as to translate the human operator intentions to ideal trajectories that the robot must follow. It works as an automaton with two states of motion whose transitions are controlled by comparing the magnitude of the force to an adjustable threshold, in order to enable the operator to keep authority over the robot's states of motion. The key idea of this approach consists in generating a velocity trajectory for the end-effector that would stay collinear at every moment to the PHRI force. The overall strategy is applied to a two DOF robot.

keywords: Physical Human-Robot Interaction; Co-manipulation; Online Trajectory Generation; Impedance Control

1 Introduction

For the past ten years, robots are more and more envisioned as helpers of mankind, closely cooperating with and assisting people in their daily life. Several active areas of research concern physical human-robot interaction (PHRI). In [Charnnarong et al., 1995], robots help in alleviating therapists of the physical rigors of their work, freeing them to concentrate on patient needs. The concept of human extender was introduced in [Kazerooni and Guo, 1993] and deeply studied. The purpose was to boost the force capacity of human limbs while retaining the human brain as the high-level controller. These devices allow human operator (HO) and robot to exchange mutually informations: the HO applies small forces along a desired direction where he wants to drive the robot, and the robot's position is sensed by the HO. The robot assists the HO during his motion while relieving him from the important effort without any human perceptible resistive forces like inertia, friction *etc.* The concept of *virtual fixtures* was introduced in [Rosenberg, 1993] and conceived as collaborative control strategies that help humans to perform robot-assisted manipulation tasks by limiting movement into restricted regions and/or by influencing movement along desired paths. The benefits of virtual fixtures for PHRI were evaluated in [Bowyer et al., 2013] in order to improve the HO's performance in terms of both speed and accuracy, since they can alert the user for changes in the state of the environment and support hand-eye coordination for object manipulation tasks. During PHRI, the skills of HO and industrial robot should be combined and the resulting cooperative motion should be truly intuitive and should not restrict in any way the human motion. This is often referred to as transparency. There are still many challenges on the road to achieving an efficient PHRI [Santis et al., 2008]. These challenges are mainly related to the fundamental problem of ensuring the user safety. Any collision involving the robot and the human must result in a soft bouncing of the robot. This is named compliant behavior. One of the most commonly used control approach to give interactive robots a compliant behavior is the so called impedance/admittance control [Akella et al., 1999]. Its purpose is to reduce the interaction point (IP) mechanical impedance so as to make it equal to that of HO [Buerger, 2005]. In the context of co-manipulation for handling tasks, impedance control based methods have few drawbacks, particularly noticeable during the starting and the stopping phases.

This paper presents a novel modified impedance control method named *Online Trajectory-Based Impedance (OTBI) Control*. This control method consists of an event controlled online trajectory generator associated to a classical structure of impedance control allowing a good tracking of the generated trajectory. It is obvious that the force applied by the HO is the only physically exchanged signal, showing the robot how to move according to his will. Indeed, this force gives the information about the desired displacement direction of the end-effector. But, this direction should necessarily be collinear to the IP velocity. In [Jlassi et al., 2012], the idea of maintaining to the maximum the collinearity of the end-effector velocity and the interaction force was proposed to concur in achieving a transparent co-manipulation. The

required force to accomplish the co-manipulation task is supplied by the robot's actuators, controlled in order to ensure a good trajectory tracking. Furthermore, for sake of safety, we consider that the displacement velocity should not entirely depend on HO's desire but must be conform to a given velocity template. The literature provides a very rich set of approaches and algorithms of trajectory generation for industrial manipulators [Kroger, 2012]. In this paper we address the case of force sensor-based trajectory generation. The interaction force processing should contribute to both interpreting the triggering times of movements/immobility and in commanding how the robot has to move or stop, while leaving the final position under the human authority. The trajectory is calculated on-line, *i.e.* each desired position is updated during every control cycle because the input values based on the HO force (intensity and direction) may change unpredictably.

The remainder of this paper is organized as follows: After a brief study in Section 2 about the impedance control evolution, an analysis of the co-manipulation requirements and their consequences on the problem statement is presented in Section 3. The control strategy based on the criterion of collinearity between the interaction force and the end-effector velocity is presented in Section 4. The description of the proposed OTG is developed in Subsection 4.3. The controller design is explained in Section 4.4. Section 5 proposes an illustration of this approach for a 2DOF robot.

2 Impedance control for physical human robot interaction

Based on studies analyzing the cooperation between two human operators when accomplishing a heavy loads handling task,

the authors in [Ikeura and Inooka, 1995] have investigated the HO characteristics and have shown that the damping parameters in the impedance model are the predominant coefficients that allow setting the acceleration/deceleration features in the context of PHRI. In the context of human-robot co-manipulation for handling tasks classical impedance control based methods have shown few drawbacks, particularly noticeable during the starting and the stopping phases. First, as explained in [Duchaine and Gosselin, 2009], the use of a fixed virtual damping can lead to an inefficient co-manipulation. Indeed, if the damping is set to a low value the robot will tend to accelerate, then, when the HO wants to stop the robot the system will be unstable and the robot arm could collapse, which may cause a serious danger to the HO. In the case of high damping, the robot will be hard to manipulate and thereby restricts the human motion. In this latter case, the human operator can not operate as fast as if it is in cooperation with another HO. Another drawback of admittance control is related to security. Admittance control is known to potentially exhibit unstable behaviour when facing rigid environments [Surdilovic, 1996]. This problem is difficult to be solved in the context of PHRI since human operators, who acts as the environment, have a variable stiffness. In order to solve these problems, the so called variable impedance control was introduced. Several works dealing with this control method were published. The variable impedance control proposed in [Ikeura and Inooka, 1995] consisted in choosing where the virtual damping coefficient between two prescribed values according to the end-effector velocity. Later, they proposed in [Ikeura et al., 2002] to adjust on-line the damping parameters, in an optimal manner by minimizing a selected cost function. An online adjustment of this coefficient based on a real-time estimation of the human arm stiffness was also proposed in [Tsumugiwa et al., 2002]. More recently, in order to insure a better PHRI with respect to transparency, it was proposed in [Duchaine and Gosselin, 2009] to continuously adapt the virtual damping coefficient as a function of the human *intention*. This method allows satisfying a good co-manipulation task. However, one drawback of this approach is that the estimation of the HO intention was performed using the time derivative of the measured force and position, for which the measurement noises can cause problems with the numerical differentiation (dividing by zero, *etc.*).

In this paper, the co-manipulation problem for load handling is addressed in a different way. The proposed control method, named *Online Trajectory generator-Based Impedance (OTBI) Control*, consists in an interconnection between an event-controlled online trajectory generator and a control structure achieving a trajectory tracking with good properties. In particular, compared to other methods, the one proposed here appears as a good alternative to overcome the static equilibrium issue while handling a load.

3 Problem description: requirements and trade-offs

This work focuses on heavy load handling tasks characterized by having motion with moderate velocities. A potential application field for the strategy proposed in this paper is the manufacturing industry such as construction industry and assembly where material handling requires considerable efforts. The main purpose is reducing these efforts, decreasing the consumed time and the costs of these activities. In the following, we consider industrial robots with a load linked to the last arm with which the HO interacts. A force sensor measures the interaction force and gives its corresponding coordinates along each direction in the end-effector frame. The robot actuators are torque controlled and without saturation. Moreover, position and velocity measurements are available.

The human-robot co-manipulation problem is considered here as the achievement of a master-slave relationship, for which the HO decides when and where the robot should move. In other words, the HO contributes in the co-manipulation process by making a visual feedback loop of the current robot configuration with the desired one that he has in mind (as depicted in Figure 1 of [Jlassi et al., 2012]). This problem consists in guaranteeing the safety of the HO while manipulating the robot from its end-effector and driving it to the desired position without having to exert the whole required force to move the load, or even to perceive the resistive forces due to the robot dynamics such as its strong inertia, joints friction etc. Hence, this problem should be designed in a way that it satisfies the co-manipulation's requirements *i.e.* security, assistance and transparency as detailed in [Jlassi et al., 2012]. The level of importance of each requirement depends on the expected purpose of co-manipulation. For the case of heavy load handling task, ensuring the maximum possible of transparency may cause a serious danger for the operator. Thus a trade-off between transparency and security appears necessary. Here, this trade-off will of-course be in favor of security. The main difference between the proposed approach and other works dealing with PHRI lies in the sought control objectives formulation. Our control objectives are based on the key concept that the velocity of the IP should remain collinear at every moment to the force exerted by the HO while being of moderate amplitude. The collinearity concurs to achieve part of the transparency requirement whereas a velocity of moderate amplitude allows to partly fulfill the security. Indeed, the standard ISO-10218 developed by the International Organization for Standardization specifies the safety requirements for the integration of industrial robots in the context of PHRI by imposing an upper bound to the velocity of the end-effector, it must not exceed $0.25m/s$. In [Moon and Virk, 2009] a study on the various existing standards was presented. All these studies show that the robot velocity is the most important parameter to control. In order to comply with the security constraint, the velocity of the robot must be bounded during the co-manipulation task. The acceleration and jerk must also be bounded to insure comfort for the HO as well as robot attrition. Notice that exerting a force is the only way for the HO to transmit the information that contains intrinsically the desired direction of displacement and this direction is given by the velocity vector at each instant. In consequence, the measured force should serve in generating a trajectory for the end-effector velocity that this latter has to track. Moreover, the trajectory to track must be generated online by an appropriate real-time processing of this information while leaving the desired position under the HO authority. To cope with safety requirement, the kinetic energy stored by the robot during the motion has to be limited by imposing either a profile or a template to the desired trajectory for the end-effector velocity. A template basically consists in imposing an upper bound on the magnitude of the end-effector velocity. But, this also requires imposing an upper bound on its successive derivatives in order to filter the tremors introduced by the exerted force. On the other hand, the choice of a profile, which consists in using parameterized functions, is easier to implement in an OTG and allows to cope with the problem of tremors. This latter approach will thus be adopted in the sequel.

4 Control Strategy

As explained previously, the control strategy is both based on the online generation of an appropriate trajectory that the end-effector has to track and a control structure for the trajectory tracking with a given impedance property. The overall

control strategy is described in Figure 1. For its implementation, the measurements of the interaction force, as well as the positions and velocities of the joints are necessary.

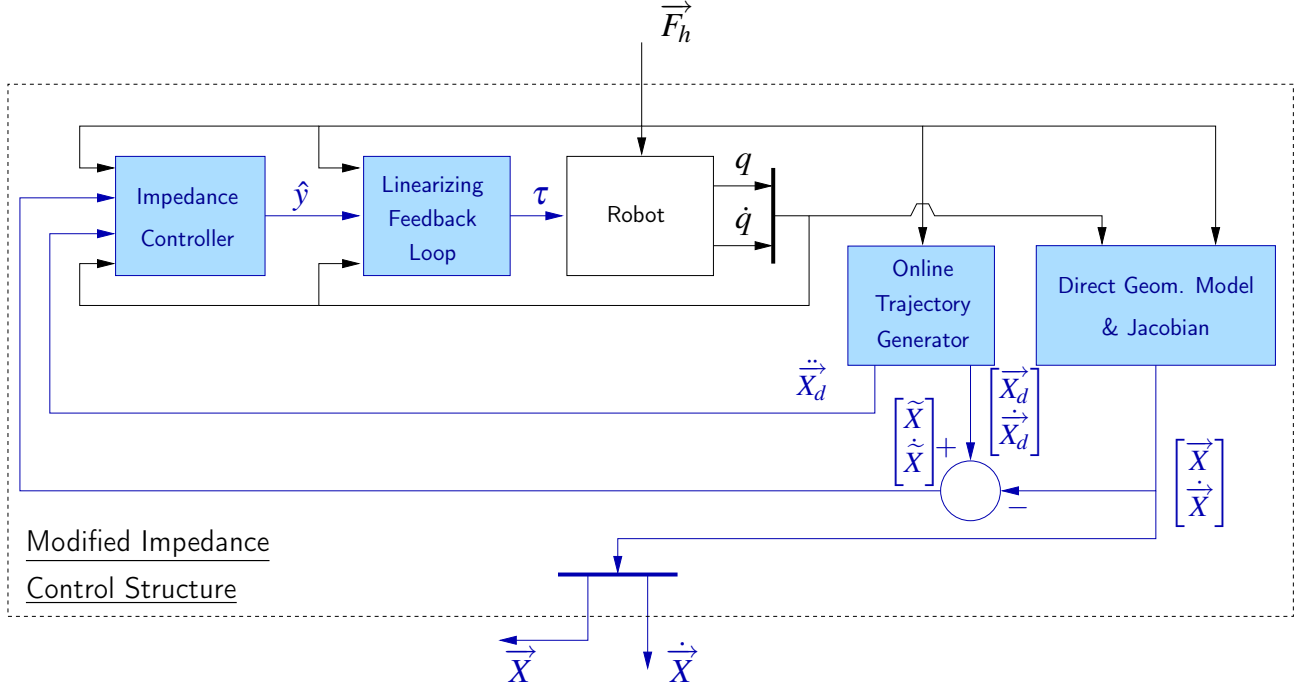

Figure 1: Modified impedance control structure.

4.1 Working frame and notations

Let n be the total number of the Degrees Of Freedom (DOFs). The dynamical model of the robot is given by

$$M(q)\ddot{q} + C(q, \dot{q})\dot{q} + g(q) = \tau + \tau_h, \quad (1)$$

where $q \in \mathbb{R}^n$, $\dot{q} \in \mathbb{R}^n$ and $\ddot{q} \in \mathbb{R}^n$ are the vectors of the generalized joints displacements, the generalized joints velocities and the generalized joints accelerations respectively. The vector of applied motor torques is denoted by $\tau \in \mathbb{R}^n$. The vector of PHRI torques is denoted by $\tau_h = J(q)^T \vec{F}_h$, where \vec{F}_h is the interaction force and $J(q)$ is the manipulator Jacobian matrix. The terms $M(q) \in \mathbb{R}^{n \times n}$, $C(q, \dot{q}) \in \mathbb{R}^n$ and $g(q) \in \mathbb{R}^n$ are employed to denote the inertia matrix, the vector of centrifugal and Coriolis forces and the vector of gravitational forces respectively. In the following, we denote the desired task space positions, velocities, and accelerations as $\vec{X}_d := [x_d \ y_d]^T \in \mathbb{R}^2$, $\dot{\vec{X}}_d$, and $\ddot{\vec{X}}_d$, respectively. Without loss of generality we will focus our development on the case of planar robots. Let $\vec{X} := [x \ y]^T \in \mathbb{R}^2$ be the position vector of the end-effector and $\vec{F}_h \in \mathbb{R}^2$ the vector of forces exerted at the end-effector. This force vector is characterized by its Euclidean norm noted $F_h := \|\vec{F}_h\|_2$ and its orientation, defined by the unitary vector, noted \vec{U}_{θ_h} where θ_h is the angle formed by the interaction force \vec{F}_h and a unitary vector of the fixed frame.

4.2 Collinearity between force and end-effector velocity

As mentioned in Section 3, maintaining to the maximum the collinearity of the end-effector velocity and the interaction force while having the same direction, should concur in achieving a transparent co-manipulation. The co-manipulation expected requirements should lead the end-effector velocity and the interaction force to satisfy a relationship like

$$\dot{\vec{X}} = \chi(q, \dot{q}, \vec{F}_h), \quad (2)$$

under the constraints of zero cross-product $\vec{\dot{X}} \times \vec{F}_h = \vec{0}$ and of positive scalar product $\langle \vec{\dot{X}} | \vec{F}_h \rangle > 0$, where $\chi(q, \dot{q}, \vec{F}_h)$ is a mathematical operator that can be assimilated to an admittance relationship, but which expression is non-trivial and certainly hard to express analytically, because it has to satisfy all the requirements in an optimal manner. In particular, $\chi(q, \dot{q}, \vec{F}_h)$ should be able to cope with discrete events such as the human decision of starting or stopping the robot motion, and to maintain a stable robot equilibrium position, robust to exogenous disturbances. Usually, this operator is described in frequency domain and taken as a linear admittance. As mentioned in Section 2, it is hard to cope with start and stop phases using simply linear admittance. In this paper, the seeking of the operator $\chi(q, \dot{q}, \vec{F}_h)$ is addressed using a two-step approach, following the method described thereafter.

4.3 Online Trajectory Generator

The block diagram of this component is described by Figure 2. Each step of the interaction force measurement processing is detailed and justified in the sequel.

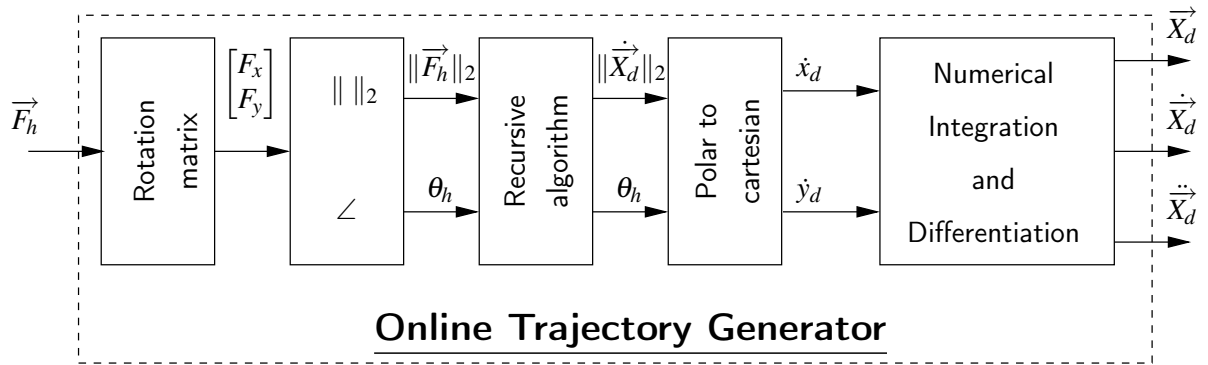

Figure 2: Block diagram of the Online Trajectory Generator.

a) Force intensity processing

Define two force thresholds, the first noted f_{th+} allows distinguishing the intention to move the robot if the interaction force amplitude is greater than f_{th+} with a rising edge. The second, noted f_{th-} , is used to detect the will to stop it if the force is lower. Both threshold concur in defining a hysteresis detection to prevent small changes corresponding to unwanted triggering events, from having any effect. Let h_r be the logical quantity that switches to 1 when the force measurement crosses the threshold f_{th+} with a rising edge and h_f that switches to 1 when the force measurement crosses the threshold f_{th-} with a falling edge. When h_r switch to 1, it means that the robot enters into a state of motion, noted Σ_{motion} , and it remains there. It is therefore an event from which two phases follow each other, a transient phase corresponding to the motion startup, noted ϕ_{rise} , and a phase of established motion, ϕ_{cruise} . When h_f switch to 1, it means that the robot enters into a state of immobility, noted Σ_{imm} , and stops at the desired position. It is also an event from which two phases follow each other, a transient phase corresponding to the decelerating motion until the stop, noted ϕ_{fall} , and another one in which the robot configuration is maintained in a equilibrium position, ϕ_{stop} . To realize a more natural motion, the transient phases and the one of established motion should be customizable. Let ϵ_f be the duration of ϕ_{fall} and ϵ_r that of ϕ_{rise} . These settings depend on the nature of the manipulated object, its environment and the HO's and robot capabilities. The customization of the transient part should allow adjusting the reaction time to match the minimum effort that can apply the operator, according to his abilities. The setting of the established motion phase should be compatible with the constraint imposed on the IP's velocity, *i.e.* with a velocity of constant and moderate amplitude, noted V_0 . Only the duration control of ϕ_{stop} and ϕ_{cruise} is left to the HO's decision. Hence, the interaction force processing allows the identification of the initiation moment denoted t_0 , of the rising or the falling phase, making thus the OTG event-controlled with two discrete states governed by the automaton of Figure 3. This moment is captured by comparing continuously the increasing magnitude of this force with f_{th+} or the decreasing magnitude with f_{th-} . The sequencing of each phase always

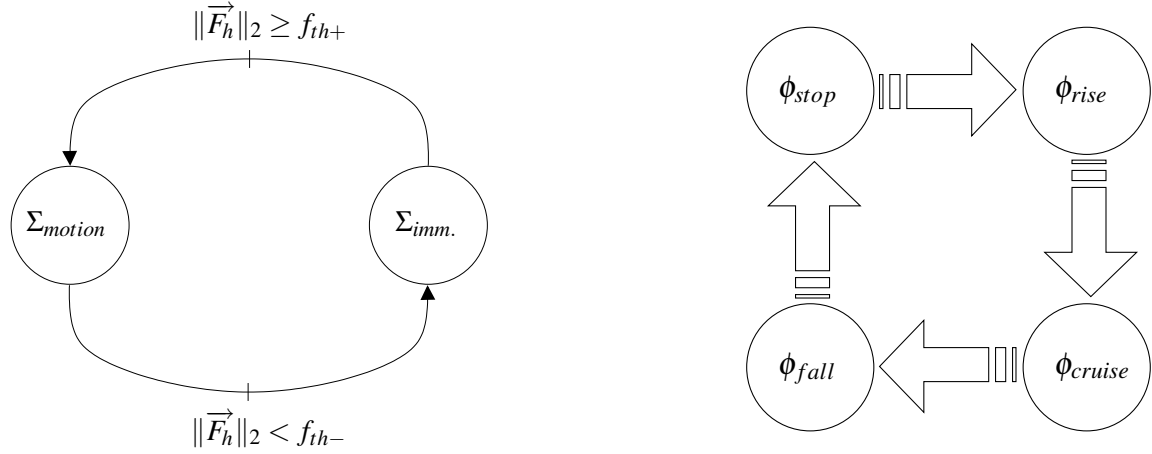

Figure 3: Automaton governing the motion states (left). Periodical cycle of phases (right).

follows the same closed periodical cycle as depicted in Figure 3. Figure 4 depicts the force F_h , the trajectory progression of the end-effector velocity during PHRI and the force thresholds. In this figure, we voluntarily increased the reaction times in order to distinguish the different succeeding motion phases, depending on the position of F_h with respect to the force thresholds. The durations of each phase (ϕ_{stop} , ϕ_{rise} , ϕ_{cruise} and ϕ_{fall}) is shown.

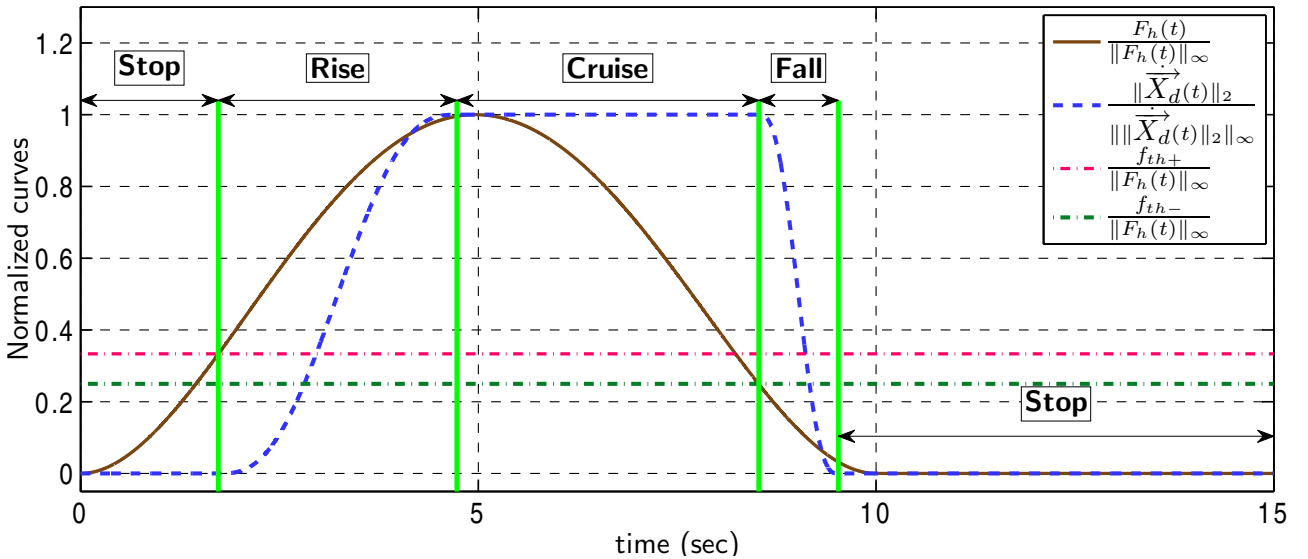

Figure 4: Desired velocity profile generated by the processing of the interaction force measurement.

b) Low-jerk velocity profile

The role of the OTG is to convert the real-time processing of the interaction force into displacement instructions of the IP, that depend on the phase in which is the PHRI. These instructions should rely on a specific velocity profile, noted $V_p(t)$, that meets the expected requirements on the norm of \vec{X}_d , viz safety, transparency and fluidity of movement interaction. A clear understanding of the human arm motions, as studied extensively by authors in [Tee et al., 2010], should contribute to a better consideration of the co-manipulation requirements in the definition of the trajectories to track. However, for simplicity and conciseness reasons of this paper, we made the choice of not including the human arm's dynamic to model the PHRI in terms of force and common trajectories, whereas it should be included for a more rigorous and complete study. In return, a simpler representation of the PHRI is considered. Since natural trajectories are required for a safe, smooth and comfortable interaction between the HO, the robot and the hanged load, we adopted the minimal-jerk trajectories to represent the PHRI. Indeed, smoothness can be quantified as a function of jerk as reported in [Hogan, 1985]. It is now

well established and experimentally demonstrated that limiting jerk is important for reducing the robot attrition as well as for improving fast and accurate tracking [Piazzi and Visioli, 2000]. Moreover, it leads to a smoother control of the actuators, which reduces the excitation of the manipulator's fast dynamics such as vibrating modes. This consequently reduces danger for the HO, wear of the actuators, *etc.* To gather these specifications, the proposed low-jerk time function $V_p(t)$ imposed to $\|\vec{X}_d\|$ and satisfying each phase's requirement is given by a piecewise defined polynomial based on the following quintic polynomial

$$V_p(t) = V_i + (V_f - V_i) \left(10 \left(\frac{t-t_0}{T} \right)^3 - 15 \left(\frac{t-t_0}{T} \right)^4 + 6 \left(\frac{t-t_0}{T} \right)^5 \right)$$

where T , V_i and V_f are parameters governed by the current phase, as described in Table 1.

Phase	Parameters setting	Velocity profile expression
ϕ_{stop}	$T \neq 0, V_i = 0, V_f = 0$	$V_p(t) = 0$
ϕ_{rise}	$T = \varepsilon_r, V_i = 0, V_f = V_0$	$V_p(t) = V_0 \left(10 \left(\frac{t-t_0}{\varepsilon_r} \right)^3 - 15 \left(\frac{t-t_0}{\varepsilon_r} \right)^4 + 6 \left(\frac{t-t_0}{\varepsilon_r} \right)^5 \right)$
ϕ_{cruise}	$T \neq 0, V_i = V_0, V_f = V_0$	$V_p(t) = V_0$
ϕ_{fall}	$T = \varepsilon_f, V_i = V_0, V_f = 0$	$V_p(t) = V_0 \left(1 - 10 \left(\frac{t-t_0}{\varepsilon_f} \right)^3 + 15 \left(\frac{t-t_0}{\varepsilon_f} \right)^4 - 6 \left(\frac{t-t_0}{\varepsilon_f} \right)^5 \right)$

Table 1: Phase dependent velocity profile expression.

c) Force direction processing

The desired velocity \vec{X}_d of the IP should remain collinear at every moment to the force exerted by the HO while having the same direction. Thus the angle formed by the IP's desired velocity and the interaction force $\left(\vec{X}_d, \vec{F}_h \right)$ should be zero during the co-manipulation task, which is equivalent to ensuring $\vec{X}_d \times \vec{F}_h = 0$ with $\langle \vec{X}_d | \vec{F}_h \rangle > 0$. In other words, \vec{X}_d should have the same orientation angle than \vec{F}_h , namely θ_h . So, the direction to track, given by the unitary vector \vec{U}_{θ_h} , has to be extracted from the measured force \vec{F}_h . The force sensor delivers the coordinates of \vec{F}_h in the end-effector frame. A simple use of rotational transformations gives the corresponding coordinates in task space frame, $\vec{F}_h = \begin{bmatrix} F_x & F_y \end{bmatrix}^T$. Then, the orientation angle is given by $\theta_h = \tan^{-1} \left(\frac{F_y}{F_x} \right)$. In consequence, once the desired norm of \vec{X}_d computed as indicated in Paragraph b), the coordinates of \vec{X}_d in task-space frame are easily derived by the relation: $\vec{X}_d = V_p \vec{U}_{\theta_h}$. The desired position \vec{X}_d is obtained by a coordinate numerical integration of \vec{X}_d , using for example an Euler explicit method, whereas the corresponding acceleration ($\ddot{\vec{X}}_d$) is deduced through basic numerical differentiation.

d) Recursive algorithm

Because the HO may change his desired motion unpredictably (a sudden presence of an obstacle, an unexpected change of destination *etc.*), the real-time processing of the interaction force requires to store the starting or stopping moment t_0 of the robot's motion in memory, together with the values of the corresponding state, *i.e.* position, velocity and acceleration. Since the desired motion signals $\left(\vec{X}_d, \dot{\vec{X}}_d, \ddot{\vec{X}}_d \right)$ are generated in real-time, the information needed at the next computation cycle must be stored at each instant. Thereby, the algorithm for generation of these guidelines is necessarily recursive. It is described by the block diagram in Figure 5.

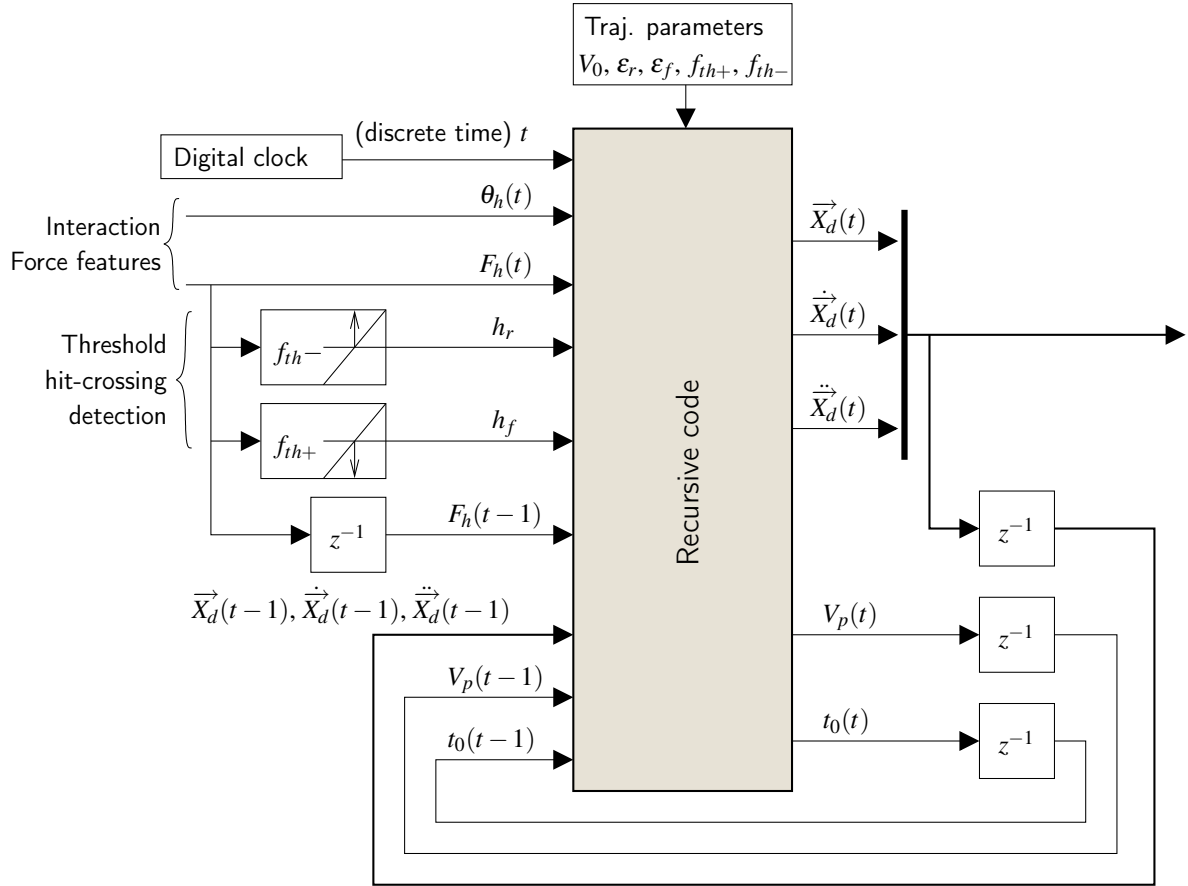

Figure 5: Block-scheme of the recursive algorithm.

4.4 Trajectory tracking with given impedance property

It is assumed here that the robot never takes a singular configuration, so that the Jacobian is always invertible. Moreover, the joints' positions and velocities are assumed to be measured. The robot parameters and the handled load are supposed to be quite well known. As indicated in Figure 4, the trajectory tracking is ensured through two controllers. The first realizes a linearization of the nonlinear motion equations in (1). It is based on the control law

$$\tau = M(q)\hat{y} + C(q, \dot{q})\dot{q} + g(q) - J(q)^T \vec{F}_h, \quad (3)$$

where \hat{y} is a new input vector whose expression is given thereafter. Substituting (3) in (1) and by considering the invertibility of $M(q)$, then, the motion equations (1) become

$$\ddot{q} = \hat{y}. \quad (4)$$

The second controller is design, from the exact linearized system in (4), in order to ensure trajectory tracking in task space, with some properties stated by the desired mechanical impedance of the robot along these trajectories. According to [Hogan, 1985], an impedance controller imposes, along each direction of the task space, a desired impedance relation between the robot end-effector displacement and the interaction force. Usually, the desired impedance is chosen linear and of second order, as in a mass-spring-damper system. In that case, it is given, in Laplace domain,

$$F_h(s) = Z(s)\dot{X}(s),$$

where Z is the desired mechanical impedance and $s \in \mathbb{C}$ is the Laplace variable. In terms of end-effector position, we can write

$$F_h(s) = sZ(s)X(s),$$

where $sZ(s) := M_d s^2 + B_d s + K_d$,

M_d , B_d and K_d are the desired inertia, damping and stiffness matrices of mass-spring-damper system respectively.

Let $\tilde{X} = \vec{X}_d - \vec{X}$, the task space error between the desired and the actual end-effector position. Let the control law of the second controller be given by

$$\hat{y} = J^{-1} M_d^{-1} \left(M_d \ddot{\tilde{X}}_d + B_d \dot{\tilde{X}} + K_d \tilde{X} - M_d J \dot{q} - \mathcal{W} \vec{F}_h \right). \quad (5)$$

Since we have

$$\ddot{\tilde{X}} = J \ddot{q} + \dot{J} \dot{q},$$

then, the resulting impedance control along the trajectories is

$$M_d \ddot{\tilde{X}} + B_d \dot{\tilde{X}} + K_d \tilde{X} = \mathcal{W} \vec{F}_h,$$

where $\mathcal{W}(q) := J(q)M(q)^{-1}J^T(q)$ (called the *mobility tensor*). As indicated in [Siciliano et al., 2009], the matrices M_d , B_d and K_d must be chosen to be constant and diagonal, positive definite for M_d and semi-positive definite for B_d and K_d . The convergence speed of the tracking error depends on the values taken for these matrices. These parameters also permit to tune the impedance felt by the HO when the robot tracks the generated trajectory. A stiff impedance allows a rejection of an excessive interaction force amplitude during the co-manipulation, but it decreases the feeling of comfort and smoothness of the physical interaction, *i.e.* the transparency. On the contrary, an elastic impedance increases the feeling of transparency but it deteriorates the tracking properties like precision, speed *etc.*

5 Application and simulation results

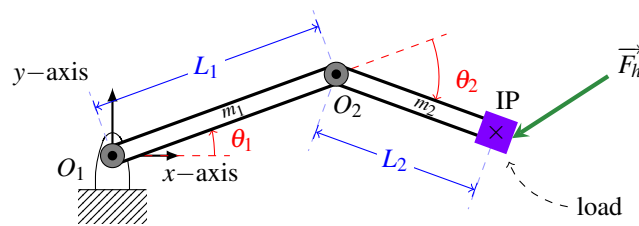

Figure 6: A planar robot with two joints holding a load of mass M .

Our control strategy is illustrated through the planar robot with two joints depicted in Figure 6. This robot holds a load of mass M at the end-effector. Each joint is actuated with its own motor. The first [*respectively* the second] is located at point O_1 [*resp.* O_2] and exerts a torque denoted τ_1 [*resp.* τ_2]. The angular position of the first [*resp.* the second] arm with respect to the fixed frame [*resp.* w.r.t. the first arm] is denoted by θ_1 [*resp.* θ_2]. The HO drives the robot by applying a force \vec{F}_h at the IP.

Denote by $q = [q_1 \ q_2]^T := [\theta_1 \ \theta_1 + \theta_2]^T$. The following simulations were done using MATLAB. The parameters are $m_1 = 10 \text{ kg}$, $m_2 = 8 \text{ kg}$, $M = 2 \text{ kg}$, $L_1 = 5 \text{ m}$, $L_2 = 4 \text{ m}$ and $g = 9.81 \text{ m/s}^2$. The rise and fall times are set to $\varepsilon_r = \varepsilon_f = 0.3 \text{ s}$. The thresholds are set to $f_{ih+} = 1 \text{ N}$ and $f_{ih-} = 0.75 \text{ N}$.

As a first step, in order to emphasize the importance of the collinearity criterion, a *simulation test* was done. To move the load, without the mechanical power's assistance of the robot, from the initial position ($q_1^i = -\pi/3, q_2^i = \pi/18$)

to the final one ($q_1^f = -\pi/6, q_2^f = \pi/4$), the HO needs to apply a force whose amplitude and direction are as shown in Figure 7 (left). This force results in a velocity of the end-effector shown in Figure 7 (right). One can notice that force and end-effector velocity have not the same direction. For the case of co-manipulation, the HO is now exerting a force having the same direction (orientation) than that of the end-effector velocity from the *simulation test*, but with a considerably lower amplitude, in order to emphasize the satisfaction of the assistance criterion, *i.e.* in order to show that the robot ensures the provision of the necessary power to move the handled object or to maintain it in a desired equilibrium position. The impedance parameters are set as follows: $M_d = \text{diag}(1, 1)$, $B_d = \text{diag}(198, 198)$ and $K_d = \text{diag}(0, 0)$. The trajectory tracking simulations for the obtained control law are depicted in Figure 9. One can observe a good trajectory tracking for both position and velocity. Figure 8 highlights the fulfillment of the requirement of collinearity between the force applied by the HO and the velocity of the end-effector. This collinearity is obviously observed during the motion state. When the norm of the applied force crosses the threshold f_{th+} while increasing, the velocity of the end-effector quickly converges toward the orientation of the force and it remains collinear till the occurrence of the immobility state.

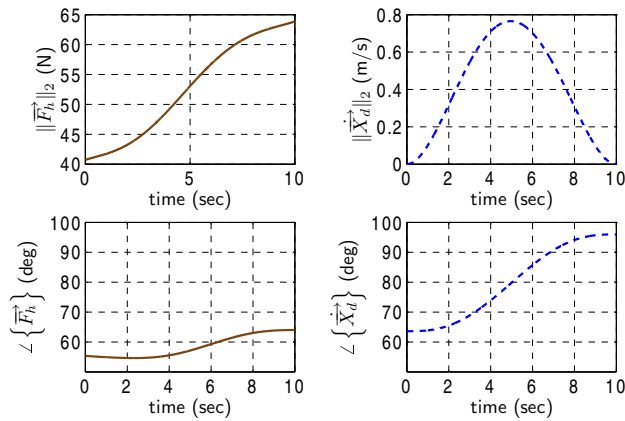

Figure 7: Directions (bottom) and amplitudes (top) of the interaction force (left) vs the IP velocity (right), case of *simulation test*.

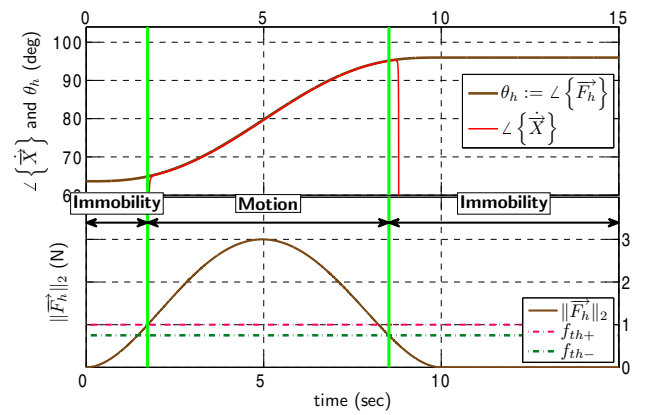

Figure 8: Top: collinearity achievement between the interaction force and the velocity of the end-effector. Bottom: amplitude of the applied interaction force.

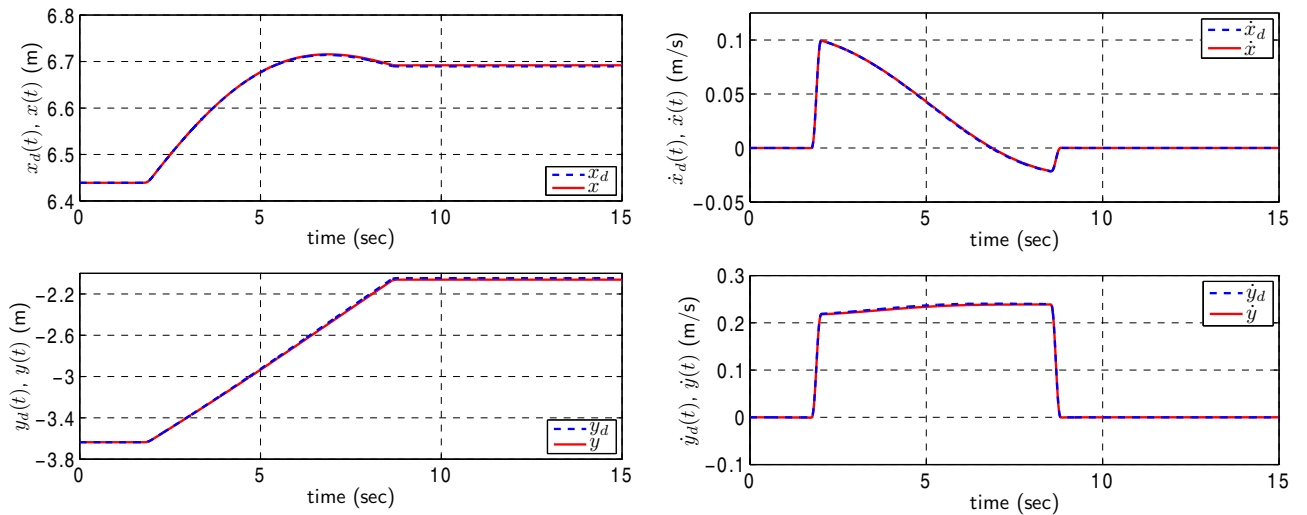

Figure 9: Trajectory tracking: coordinates, in the fixed reference, of the IP position (left) and velocity (right).

6 Conclusion

This paper addressed the co-manipulation problem for handling tasks through a modified impedance control method named *Online Trajectory-generator Based Impedance (OTBI) Control*. This approach mainly lies on the implementation

of a specific event-controlled online trajectory generator (OTG), that delivers trajectories to track when the operator exerts a force which amplitude is greater than a given threshold of low intensity, combined with a control structure that ensures a trajectory tracking with an impedance property. The proposed approach permitted to address the issue of maintaining the immobility of the robot configuration when there is no interaction force.

References

- [Akella et al., 1999] Akella, P., Peshkin, M., Colgate, E., Wannasuphprasit, W., Nagesh, N., Wells, J., Holland, S., Pearson, T., and Peacock, B. (1999). Cobots for the automobile assembly line. In *Robotics and Automation, ICRA'99. Proc. of IEEE Int. Conf. on*, volume 1.
- [Bowyer et al., 2013] Bowyer, S., Davies, B., and Rodriguez y Baena, F. (2013). Active constraints/virtual fixtures: A survey. *Robotics, IEEE Trans. on*, pages 1–20.
- [Buerger, 2005] Buerger, S. (2005). *Stable, High-force, Low-impedance Robotic Actuators for Human-interactive Machines*. Massachusetts Institute of Technology, Department of Mechanical Engineering.
- [Charnnarong et al., 1995] Charnnarong, J., Hogan, N., Krebs, H. I., and Sharon, A. (1995). Interactive robot therapist. In *US Patent*, volume 5.
- [Duchaine and Gosselin, 2009] Duchaine, V. and Gosselin, C. (2009). Safe, stable and intuitive control for physical human-robot interaction. In *Robotics and Automation, ICRA'09. Proc. of IEEE Int. Conf. on*.
- [Hogan, 1985] Hogan, N. (1985). Impedance control - An approach to manipulation. I - Theory. II - Implementation. III - Applications. *ASME Trans. Journal of Dyn. Syst., Meas. and Control B*, 107:1–24.
- [Ikeura and Inooka, 1995] Ikeura, R. and Inooka, H. (1995). Variable impedance control of a robot for cooperation with a human. In *Robotics and Automation, ICRA'95. Proc. of the IEEE Int. Conf. on*, volume 3.
- [Ikeura et al., 2002] Ikeura, R., Moriguchi, T., and Mizutani, K. (2002). Optimal variable impedance control for a robot and its application to lifting an object with a human. In *Robot and Human Interactive Communication. Proc. of the 11th IEEE Int. Workshop on*, pages 500–505.
- [Jlassi et al., 2012] Jlassi, S., Tliba, S., and Chitour, Y. (2012). On human-robot co-manipulation for handling tasks: Modeling and control strategy. In *Proc. of the 10th IFAC Symposium on Robot Control (SYROCO 2012)*, page 710, Dubrovnik, Croatia.
- [Kazerooni and Guo, 1993] Kazerooni, H. and Guo, J. (1993). Human extenders. *Journal of Dyn. Syst., Meas. and Control*, 115:281 – 290.
- [Kroger, 2012] Kroger, T. (2012). On-line trajectory generation: Nonconstant motion constraints. In *Robotics and Automation, ICRA'12. Proc. of IEEE Int. Conf. on*, pages 2048–2054.
- [Moon and Virk, 2009] Moon, S. and Virk, G. (2009). Survey on iso standards for industrial and service robots. In *ICCAS-SICE, 2009*, pages 1878–1881.
- [Piazzi and Visioli, 2000] Piazzi, A. and Visioli, A. (2000). Global minimum-jerk trajectory planning of robot manipulators. *Industrial Electronics, IEEE Trans. on*, 47(1):140–149.
- [Rosenberg, 1993] Rosenberg, L. B. (1993). Virtual fixtures: Perceptual tools for telerobotic manipulation. In *Proc. of the IEEE Virtual Reality Annual International Symposium*, Washington, DC, USA. IEEE Computer Society.

- [Santis et al., 2008] Santis, A. D., Siciliano, B., Luca, A. D., and Bicchi, A. (2008). An atlas of physical human-robot interaction. *Mechanism and Machine Theory*, 43(3):253–270.
- [Siciliano et al., 2009] Siciliano, B., Sciavicco, L., Villani, L., and Oriolo, G. (2009). *Robotics: Modelling, Planning and Control*. Springer-Verlag.
- [Surdilovic, 1996] Surdilovic, D. (1996). Contact stability issues in position based impedance control: theory and experiments. In *Robotics and Automation, ICRA'96. Proc. of the IEEE Int. Conf. on*, volume 2.
- [Tee et al., 2010] Tee, K. P., Franklin, D. W., Kawato, M., Milner, T. E., and Burdet, E. (2010). Concurrent adaptation of force and impedance in the redundant muscle system. *Biol. Cybern.*, 102(1).
- [Tsumugiwa et al., 2002] Tsumugiwa, T., Yokogawa, R., and Hara, K. (2002). Variable impedance control based on estimation of human arm stiffness for human-robot cooperative calligraphic task. In *Robotics and Automation, ICRA'02. Proc. of the IEEE Int. Conf. on*, volume 1, pages 644–650.