



HAL
open science

Effects of exercise during growth and alternative rearing systems on muscle fibers and collagen properties

Florence Gondret, Sylvie Combes, Louis Lefaucheur, Bénédicte Lebreton

► To cite this version:

Florence Gondret, Sylvie Combes, Louis Lefaucheur, Bénédicte Lebreton. Effects of exercise during growth and alternative rearing systems on muscle fibers and collagen properties. *Reproduction Nutrition Development*, 2005, 45 (1), pp.69-86. 10.1051/rnd:2005003 . hal-00900543

HAL Id: hal-00900543

<https://hal.science/hal-00900543v1>

Submitted on 11 May 2020

HAL is a multi-disciplinary open access archive for the deposit and dissemination of scientific research documents, whether they are published or not. The documents may come from teaching and research institutions in France or abroad, or from public or private research centers.

L'archive ouverte pluridisciplinaire **HAL**, est destinée au dépôt et à la diffusion de documents scientifiques de niveau recherche, publiés ou non, émanant des établissements d'enseignement et de recherche français ou étrangers, des laboratoires publics ou privés.

Effects of exercise during growth and alternative rearing systems on muscle fibers and collagen properties

Florence GONDRET^{a*}, Sylvie COMBES^b, Louis LEFAUCHEUR^a,
Bénédicte LEBRET^a

^a INRA, Unité Mixte de Recherches sur le Veau et le Porc, 35590 Saint Gilles, France
^b INRA, Station de Recherches Cunicoles, BP 27, 31326 Castanet-Tolosan Cedex, France

(Received 10 June 2004; accepted 15 October 2004)

Abstract – Muscle characteristics, and particularly fiber type frequency and collagen properties, may be a source of variation in eating meat quality. Expanded space allowance in alternative breeding systems theoretically increases animal physical activity during growth. This review deals with effects of endurance training and spontaneous exercise in large areas in- and out-doors, on muscle characteristics in rabbits and pigs, two species of agronomic interest, and rats. Endurance training induces a fast-to-slower transition in myofiber contractile characteristics, following the IIB → IIX → IIA → I transformation sequence. These changes are accompanied by a greater ability to transport fatty acids intracellularly, and (or) by enhanced activities of the mitochondrial reference enzymes. Newly synthesized heat-soluble collagen may be observed in the recruited muscles after endurance training in rats. Depending on the experiments (stocking density, ambient temperature, gender, and muscles), area allowance in- or out-of-doors, does not affect fiber type frequency compared with conventional systems or results in a lower proportion of type IIB/X fibers at the benefit of slower twitch fibers. Muscle lipids and collagen content are generally not modified by expanded indoor area, however, a higher proportion of non-soluble collagen may be observed in free-range animals in doors compared with confined ones. It is impossible to state a general rule for lipid stores and collagen properties in animals reared out-of-doors. Therefore, exercise studies are unsuitable to predict adaptative responses in muscle characteristics to alternative outdoor rearing systems, and in fine meat quality.

myofiber type / intramuscular lipids / pig / rabbit / exercise / collagen heat-solubility

1. INTRODUCTION

Skeletal muscle is a heterogeneous tissue mainly composed of myofibers embedded into connective tissue. Individual muscle fibers are separated by the endomysium, whereas fiber fascicles are delineated by the

perimysium, in which adipocytes may develop. Finally, the epimysium surrounds the entire muscle. Contractile and metabolic properties of muscle fibers play a key role in muscle function, determining the speed of contraction, force velocity, and resistance to fatigue. Collagen, the main protein in

* Corresponding author: Florence.Gondret@rennes.inra.fr

muscle connective tissue, is generally described as a supporting, force-transferring and absorbing element that prevents the myofibers from over-stretching [1]. Besides these physiological functions, the size and type frequency of the myofibers have been reported to influence meat texture and eating quality traits [2–4]. Evidence from bovines also indicates that connective tissue myofibrils, especially the quantity of collagen and thermal stability of collagen cross-links, may influence meat firmness and mechanical properties [5, 6]. The results are far less numerous in other species and not conclusive [7], although a relationship between soluble collagen levels and technological yield of the processed meat has been suggested in pigs [8].

Breeding factors act differently on these muscle characteristics, depending on whether they concern foetal, perinatal, or growing periods. Attention has been recently focused on the myogenic programming and postnatal myofiber development, as affected by early nutrition [9], genetic factors [10], or hormonal treatments [11]. It is also well-known that the amount, composition, and arrangement of the intramuscular connective tissue change with age in bovines [12, 13], however variations in collagen properties during growth have been less investigated in farm monogastrics than in laboratory rats [14]. Finally, physical stimuli induced by chronic electrical stimulation [15] or by endurance training [14] are known to affect both myofiber characteristics and collagen properties in laboratory rodents.

In farm species, there has been a growing interest in alternative breeding systems, since meat quality and animal welfare are thought to be improved [16]. Since space allowance is expanded, and distance between bedding and feeding area is increased in these breeding systems, in- or out-of-doors, the effects of physical activity during growth on the muscle properties are now of practical importance. The aim of this review was to address whether endurance training during growth, and spontaneous exercise in expanded areas,

in- or out-of-doors, may influence muscle fiber characteristics, energy metabolic equilibrium, and collagen properties in pigs and rabbits. Data derived from trained rats are illustrated.

2. MUSCLE CHARACTERISTICS DURING NORMAL GROWTH

2.1. Myofibers

Based on the histochemical myofibrillar ATPase technique [17], myofibers in adult muscles have been classified for a long time into slow-twitch fatigue-resistant type I with a low ATPase activity and force production, and fast-twitch type IIA and type IIB with a higher ATPase activity, a lower fatigue index, and a higher maximum tetanic tension. Such contractile characteristics are determined by the types of myosin cross-bridge, which are coded for by different myosin heavy chain (MyHC) isoform genes. So far, four MyHC (slow I, and fast IIA, IIX and IIB) have been evidenced in adult skeletal muscles of rats [18], rabbits [19], and pigs [2, 20]. Thus, previously named IIB fibers are actually type IIX in humans [21], and either IIX or IIB in pigs and rabbits [19, 20]. Contractile and metabolic properties are generally related [22]. Thus, slow-twitch type I fibers are rich in mitochondria, which display both higher maximal enzyme activities of the tricarboxylic acid (TCA) cycle and a superior relative capacity to oxidize fatty acids compared with mitochondria of type II fibers [23]. The three fast fiber types also differ with regards to their oxidative capacities, with type IIA fibers being the most oxidative, type IIB fibers the least oxidative, and type IIX intermediate [24]. Finally, type I fibers contain about 4-fold more intracellular triglycerides (TG) than type IIA fibers, and about 30-fold more than type IIB/X fibers, as shown in rabbits [25]. Conversely, the majority of type II fibers exhibit both higher glycogen content and glycolytic enzyme activities compared

to type I fibers [26]. Phosphocreatine content in the different fibers is aligned in an order similar to that determined by contractile power, i.e., approximately twofold higher in the fastest (IIB) fibers than in the slowest (type I) fibers [27, 28]. However, there are minor incompatibilities between contractile type and energy metabolism, with some type IIA fibers having oxidative activities as low as the majority of type IIB fibers in rabbits for instance [22].

2.2. Energy-yielding muscle substrates

Carbohydrates (muscle glycogen and blood glucose), fat (in the form of TG, non-esterified fatty acids, and ketone bodies), and phosphocreatine are the main fuels used for ATP production to provide energy for protein turnover and muscle contraction (for a review, see [29]). In muscles, the rates of oxidation of glucose and fat are generally inversely related [30]. Carbohydrates are mainly converted to lactate in fast-twitch muscle (anaerobic glycolysis), whereas they are converted into acetyl-CoenzymeA and enter the TCA cycle (oxidative catabolism) in slow-twitch muscles. Long-chain fatty acids of both extra- and intra-muscular sources may be partially degraded in peroxisomes to yield acyl-CoA with a shorter chain length, which are then transported into the mitochondrial matrix. This latter step is considered to be rate-limited by carnitine palmitoyltransferase I (CPT I) activity. Both peroxisomal and mitochondrial rates of fat oxidation are higher in slow-twitch muscles than in fast-twitch muscles [31, 32].

Overall, there is evidence that fast-twitch muscles have greater glycogen stores than slow-twitch ones [33]. On the contrary, intramuscular fat content is largely unrelated to fiber type frequency [34, 35], since TG deposited as lipid droplets represent only a small fraction (5–20%) of muscle TG content [36, 37]. Variability of muscle fat content in livestock species is then rather ascribed to changes in number and (or) size

of intramuscular adipocytes clustered along fiber fasciculi [37, 38].

2.3. Collagen

Collagen is actually a family of genetically, biochemically and immunologically different proteins [39]. More than 24 different types of collagen have been identified so far. They form a wide range of structures, nevertheless they are usually divided into two groups, the fibrillar and non-fibrillar collagens. In pigs and rats, as in other mammalian skeletal muscles, type I and III (fibrillar) collagens are distributed at all three levels of muscle connective tissue, whereas type IV (non-fibrillar) is located exclusively in the endomysial basement membrane [14, 40, 41]. Type V collagen is a minor collagen found in the endomysium [14]. It is widely accepted that collagen content in rats is higher in slow-twitch muscles involved in posture than in fast-twitch muscles used occasionally for brief voluntary movements [14]. More collagen is also observed in slow than in fast portions of a same muscle, and around slow-twitch fibers than around fast-twitch fibers dissected in a given muscle [42]. When a large number of muscles is considered (Fig. 1), there is, however, no clear relationship between collagen content and myofiber type frequency in livestock species.

Collagen structures are stabilized by the formation of covalent crosslinks, linking individual molecules and fibrils together. During collagen maturation, reducible crosslinks formed by the initial condensation products are rapidly replaced by non-reducible crosslinks, leading to increased stability, decreased solubility of the protein, and enhanced resistance to some proteases [12]. The major end result in skeletal muscle is the formation of acid-stable collagen crosslink hydroxylslylpyridinoline. A positive relationship between the degree of hydroxylslylpyridinoline cross-linking and thermal stability of collagen has been found [43]. In general, locomotor muscles possess more crosslinking than postural muscles [44].

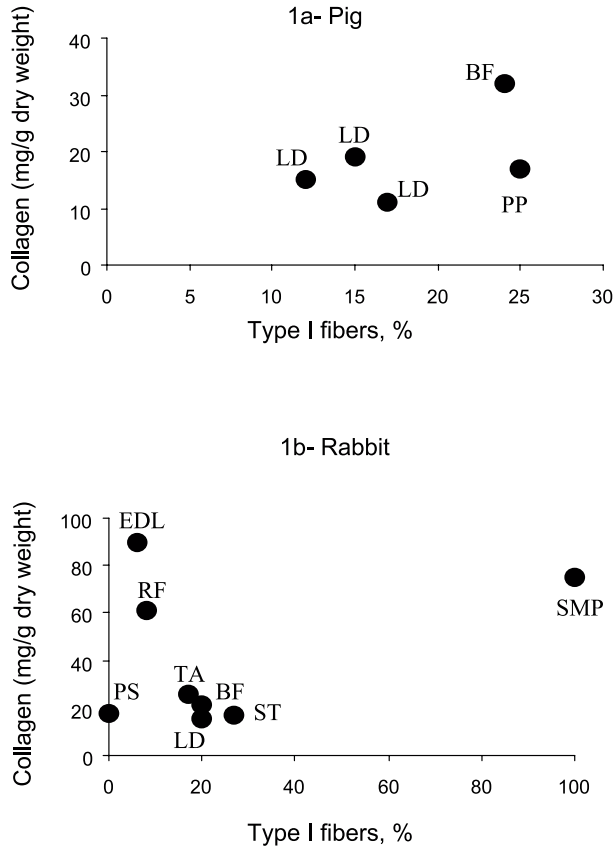

Figure 1. Collagen content in various skeletal muscles of pigs (1a) and rabbits (1b), plotted against the relative proportion of type I myofibers. The muscles under study are *biceps femoris* (BF [70, 96, 126–128]), *extensor digitorum longus* (EDL [57, 60]), *longissimus dorsi* (LD [41, 70, 96, 126]), *pectoralis profundus* (PP [41]), *psoas* (PS [57, 60]), *rectus femoris* (RF [57, 60]), *semimembranosus proprius* (SMP [57, 60]), *semitendinosus* (ST [126]), and *tibialis anterior* (TA [126]).

2.4. Age-related changes in myofiber and collagen characteristics

Fiber number is considered to be set before birth in the majority of species including pigs [45], but may continue to multiply up to 17 days post-natal in some rabbit muscles [46]. Thereafter, muscle growth occurs exclusively through an increase in fiber length and diameter, with an increase in fiber length preceding that in fiber diameter. In various species, the growth of fiber

diameter is mainly related to live weight, with a rapid increase during the immediate postnatal period followed by a decelerating rate to reach a plateau thereafter [47–49]. Another adaptation to postnatal life is the progressive changes in MyHC expression and in energy-generating enzyme activities. Embryonic and perinatal MyHC, the predominant MyHC isoforms expressed in neonatal muscles, are replaced by adult MyHC isoforms through a series of developmentally regulated transitions [20, 50, 51]

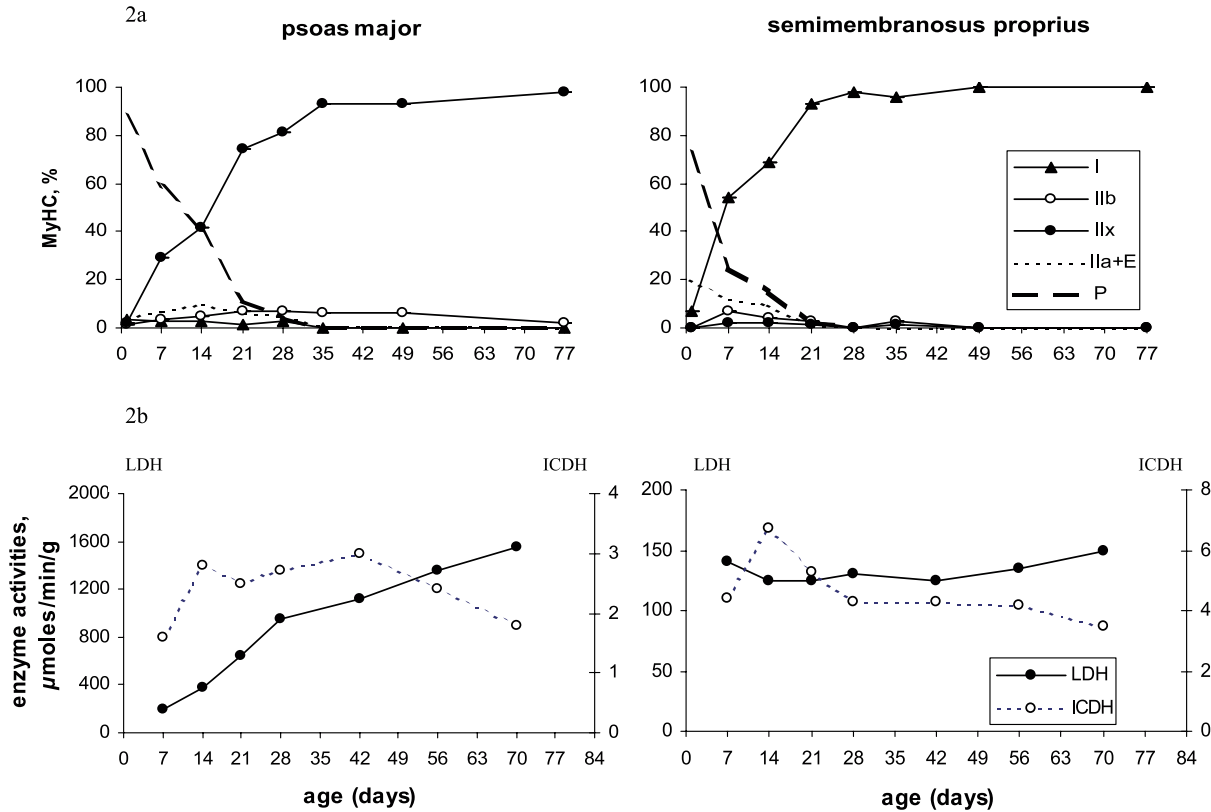

Figure 2. Age-related changes in contractile (2a) and metabolic (2b) characteristics in rabbit fast-twitch *psoas major* and slow-twitch *semimembranosus proprius* muscles. The proportions of adult (I, IIa, IIx, IIb) or developmental (embryonic [E], perinatal [P]) myosin heavy chain isoforms (MyHC) [50], and enzyme activities representative of glycolytic (lactate dehydrogenase, [LDH]) or oxidative (isocitrate dehydrogenase, [ICDH]) pathways [53] are represented against chronological age (in days).

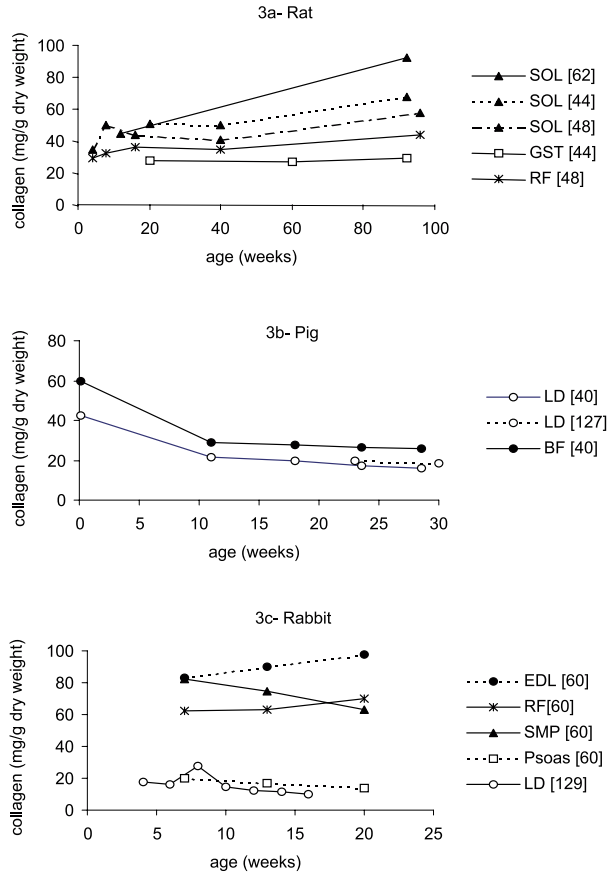

Figure 3. Age-related changes in collagen content in skeletal muscles of rats (3a), pigs (3b), or rabbits (3c). Abbreviations: *biceps femoris* [BF], *extensor digitorum longus* [EDL], *gastrocnemius* [GST], *longissimus dorsi* [LD], *rectus femoris* [RF], *semimembranosus proprius* [SMP], *soleus* [SOL].

in a muscle-specific pattern (Fig. 2). Enzyme levels in the oxidative and glycolytic pathways are low in all fibers during foetal life, however, all muscles can be classified as mostly oxidative at birth [52, 53]. Interestingly, an increase in oxidative enzyme activities is observed during 2–5 weeks following birth in the muscles of rabbits (Fig. 2) and pigs [53, 54], irrespective of energy metabolism in the adult. Thereafter, the metabolic evolution leads to an orientation towards anaerobic energy metabolism, especially in fast-twitch muscles [53–55]. In parallel, the relative proportion of lipid-rich

fibers undergoes a dramatic decrease following birth in fast-twitch muscles of pigs [56] and rabbits [37], whereas TG progressively accumulates in intramuscular adipocytes [37, 56, 57]. Surprisingly, a decrease in muscle lipid content is observed during the first months of age in fast-twitch muscles of laboratory rats [58].

Both metabolism and properties of collagen also change with age. As shown in Figure 3, an initial fall in collagen content following birth has been found in the muscles of pigs under study [40, 59] and in some rabbit muscles [60]. It can be explained by

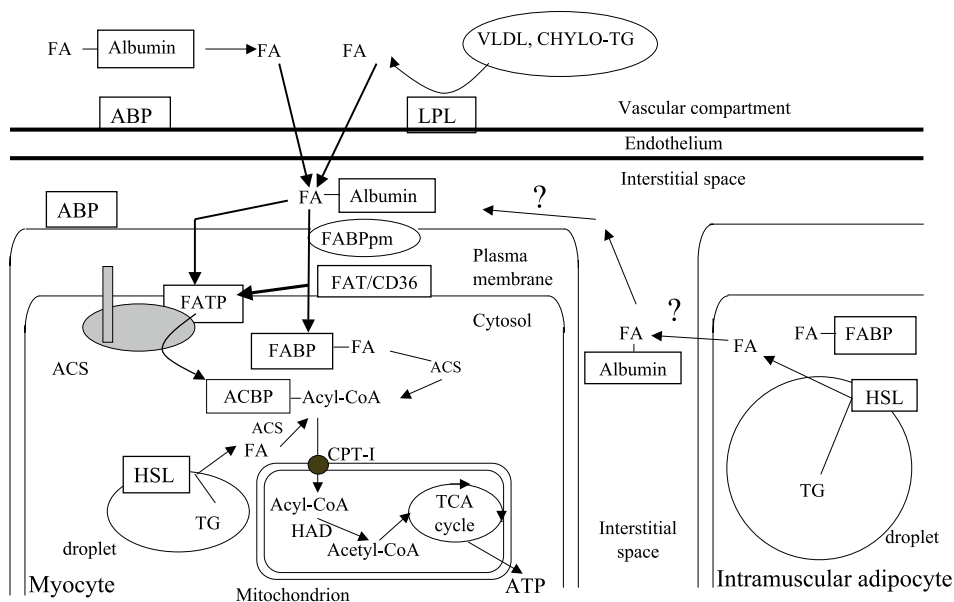

Figure 4. Proposed scheme of fatty acid transport and utilization in skeletal muscle. Fatty acids (FA) are transported to the muscle via the blood either complexed to albumin or incorporated into triglycerides (TG) in circulating chylomicrons (CHYLO) and very low density lipoproteins (VLDL). They are released from lipoproteins through the action of the lipoprotein lipase (LPL) bound to the luminal face of endothelial cells, whereas the albumin binding protein (ABP) might be decisive in the dissociation of the albumin-fatty acid complex. In the interstitial space, FA are bound again to albumin. Several proteins are putatively involved in the translocation of long-chain FA through the plasma membrane, such as fatty acid translocase with a sequence similar to human CD36 antigen (FAT/CD36), plasma membrane-associated fatty acid binding proteins (FABPpm) acting as scavenger, and a family of fatty acid transport proteins (FATP1-6). Long-chain FA could bind directly to FATP closely associated with sarcolemmal acyl-Coenzyme A synthetase (ACS). Alternatively, FA could first bind to FAT/CD36 to be delivered either to FATP, or to cytosolic fatty acid binding proteins (FABP) and activated into acyl-Coenzyme A (acyl-CoA) by intracellular ACS [131–132]. Acyl-CoA esters are bound in the aqueous cytoplasm to acyl-CoA binding proteins (ACBP). They enter into the mitochondrion via carnitine palmitoyl transferase I (CPT-I), and are cleaved in the beta-oxidation pathway (β -hydroxylacyl-Coenzyme A dehydrogenase, HAD). The acetyl-Coenzyme A molecules produced are oxidized through the tricarboxylic acid cycle (TCA). Whether fatty acids released from intramuscular adipocytes through local hormone sensitive lipase (HSL) activity may contribute a physiological relevance to lipid utilization in the myofibers during exercise is questionable.

a “dilution effect” of collagen in a period of marked increase in myofiber diameter, since activities of collagen biosynthesis enzymes are high in young tissues and fall rapidly thereafter [61]. However, an increase in collagen concentration has been reported in some rabbit muscles from weaning to sex-

ual maturity [60], and in rat muscles in youth and old age [44, 48, 62]. This probably arises from a decrease in collagen degradation out of proportion to the decrease in its synthesis [44, 62]. An enlargement in perimysium thickness with age has also been observed in pigs [63]. On the contrary,

a well established fact in all muscles is that intermolecular reducible cross-links of collagen are progressively replaced by non-reducible thermally stable hydroxylysylpyridinoline [44, 59, 64], leading to a decrease in the heat-solubility of collagen with age in pigs [40, 59], rabbits [60], and rats [44, 62]. In this process, type III collagen (a characteristic of embryonic and young tissues) is progressively replaced by type I collagen [61].

3. MUSCLE RESPONSES TO PHYSICAL TRAINING

3.1. Endurance training induces a fast-to slow-twitch fiber transformation

Endurance training consists in long-lasting and chronic exercises of moderate intensity (50–75% of the maximal oxygen consumption, VO_2max). The prevalent experimental design is treadmill training. Recruitment of particular muscles during treadmill exercise can be proven by blood flow elevation in those muscles in pigs [65] and rats [66]. When normalized by live weight, there is no clear effect of endurance training on the mean cross-sectional area of the myofibers in pigs [28] and rats [58, 67]. On the contrary, treadmill training induces a clear remodeling in fiber types proportion. Since the activation threshold is lower in type I fiber motor neurons than in type II neurons [29], type I fibers will do most of the contractile work during exercise at low intensity, while increasing numbers of type IIA, type IIX, and finally type IIB fibers will be recruited when work intensity increases. Therefore, a lower proportion of type IIB fibers is observed following endurance training, to the benefit of either type IIX ([68] in pigs), type IIA ([69, 70] in pigs; [58, 67, 71] in rats), or type I fibers ([28, 70] in pigs; [58, 67, 71] in rats). The magnitude of the switch between the three fast subtypes and eventually slow-twitch type I fibers depends on the intensity and duration of exercise, the composition and function of

the recruited muscle, and gender [70]. Changes in myofiber type composition in response to endurance training may be brought about by switching on one subset and repressing another subset of genes. As demonstrated during chronic electrical stimulation at low frequency that mimics forced contractile activity, fast-twitch muscle is optimized for fatigue resistance by sequential repression of IIB, IIX and IIA MyHC genes, and activation of the slow MyHC gene [72–74].

3.2. Endurance training induces a greater muscle reliance on fat oxidation

The rebuilding of the contractile system in response to mechanical strain of low-to-moderate intensity is accompanied by a shifting metabolism to oxidative processes. Since the capacity of the body to store carbohydrates is limited, an increased capacity to oxidize fats in working muscles during sustained exercise is advantageous. Therefore, an early adaptation to endurance training is a greater ability of the muscle cell to bind fatty acids (Fig. 4), as shown by higher fatty acid binding protein mRNA level (FABP3 isoform) in muscles from endurance-trained men or from mice undergoing voluntary wheel running [75, 76], and higher muscle CPT-I activity in rats [77]. Another adaptation concerns an increase in mitochondria number, as shown by elevated activities of mitochondrial marker enzymes in trained pigs [68, 69, 78] and rats [58, 79], and up-regulation of genes related to oxidative phosphorylation in mice [76]. These alterations in the muscle metabolic profile in response to endurance training are similar to the increase in fatty-acid translocase FAT/CD36 expression [80, 81], mitochondrial volume and enzyme activities of terminal oxidation [15], observed after chronic low-frequency stimulation of fast-twitch muscles in rats or rabbits.

Different oxidizable lipid sources are of outstanding importance to cover muscle energy demand. The relative contribution

of fatty acids derived from TG-rich lipoproteins to muscle energy production probably represents only 5–15% [82, 83]. Plasma fatty acids are considered to supply half of the fatty acids oxidized in the leg during exercise in man [84]. However, it seems unlikely that lipolysis in the adipose tissue is the rate-limiting step for muscle lipid oxidation during exercise [83]. Conversely, intra-muscular TG are supposed to be an important substrate for the contracting muscle during long-lasting moderate-intensity exercise (up to 60% VO_2max , [85]). Utilization of intra-muscular fat stores is made possible by activation of muscle hormone sensitive lipase (HSL), at both enzyme activity [86] and mRNA [75] levels. Because myofiber TG droplets are located in the close vicinity of muscle mitochondria [87], released fatty acids are then considered to be readily available for oxidation. In contrast, fatty acids released from adipocytes must be first complexed with albumin for their vascular transport to myofibers. Considering the low interstitial albumin concentration, the physiological relevance of fatty acids derived from intramuscular adipocytes during exercise is controversial. For instance, a decrease in myocellular lipids is shown after moderate exercise [88–90], whereas there is no evidence for any changes in TG stored within intra-muscular adipocytes [88]. The replenishment of myocellular stores is generally permitted by an increase in the clearance of circulating TG through elevated muscle lipoprotein lipase (LPL) activity, as evidenced in treadmill-trained rats compared to untrained animals [91]. Increased expression of sterol regulatory element-binding protein 1 (SREBP-1), a key transcription factor regulating lipogenesis from carbohydrate sources, has also been recently postulated as a new mechanism for muscle TG replenishment [92].

3.3. Endurance training effects on muscle substrate stores

In the literature, data dealing with muscle TG variation in response to exercise has

to be interpreted with caution, regarding the following factors. (1) The distinction or not between myocellular TG, adipocyte TG, and muscle total TG (the sum of myocellular TG and intra-muscular adipocyte TG). (2) The questionable representation of a needle biopsy because of the high coefficient of variation for lipid content between repeated biopsies (up to 25% according to [93]). (3) The different methodologies used to assess muscle TG content (biochemical assays, non invasive ^1H magnetic resonance spectroscopy, electron microscopic morphometry [94]). (4) The intensity, duration and pattern of the exercise. (5) The sampling time after the last bout of exercise. (6) The dietary supply before, during, and after exercise [90, 95]. As an example of controversy, muscles from treadmill-trained or untrained animals exhibit similar amounts of total lipids in pigs [96] and rats [58], whereas a higher resting myocellular TG content is observed in trained compared to untrained men [89, 97].

Because of substrate competition in energy production [30], an increased mitochondrial fatty acid oxidation during exercise may be accompanied by a reduction in muscle ability for carbohydrate catabolism in trained animals. However, major enzymes involved in glycolysis or glycogenolysis pathways are little or not affected by endurance training in the muscles of pigs [68] and rats [58]. These findings are contrasted by decreased activities of various glycogenolytic, glycolytic and gluconeogenic enzymes in muscles from rats submitted to prolonged endurance training [98], or lower activity of lactate dehydrogenase in blood from treadmill-trained rabbits [99]. Although glycogen depletion in muscle during exercise is reduced as an adaptation to endurance training, glycogen content is still depleted just after treadmill running in rabbits [100]. The average glycogen concentration in resting conditions is, however, higher in trained than in untrained pigs [78] and rats [101]. Phosphocreatine content is not affected by treadmill running in pigs [28], whereas it is improved in trained muscles of rats [101].

Taken together, these adaptations to endurance training, i.e. higher lipid and glycogen stores, are likely physiologically relevant to meet the energy demand and reduce muscle reliance on exogenous substrates during exercise.

3.4. Associated modifications in collagen properties

Treadmill training has generally no impact on muscle collagen content in pigs [96, 102] and rats [44, 62, 103, 104]. However, an increase in collagen content in slow-twitch muscles has been reported after life-long intense treadmill training in rats [48, 61]. Regular treadmill work prevents the age-related increase in hydroxylysylpyridinoline concentration in slow-twitch muscles of rats [44, 62]. Similarly, an increased proportion of heat-soluble collagen has been reported in the fast-twitch *biceps femoris* of male pigs following endurance training [96]. These changes likely result from the accretion of newly synthesized immature collagen [44], since activities of collagen biosynthetic enzymes are enhanced by endurance training [61]. Another report fails to show any evidence for training effects on the heat-solubility of collagen [103], however, collagen turn-over may be accelerated as suggested by an increased activity of prolyl 4-hydroxylase or higher incorporation of ³H-proline into collagen hydroxyproline (collagen biosynthesis) in trained rats [103, 105, 106].

4. SPONTANEOUS PHYSICAL EXERCISE IN LIVESTOCK SPECIES

The effects of increasing spontaneous physical activity with access to large areas, in- or out-of-doors, are summarized in Table I, in comparison with muscle adaptations to endurance training.

4.1. Indoor space allowance

Myofiber diameter, fiber type percentage, or muscle metabolic enzyme activities

are not affected by an exploratory behavior in large indoor pens [107], or by a moderate walk along a corridor [108, 109]. However, a contractile profile similar to that observed following treadmill training may be observed in muscles of free-range animals performing a relatively high daily amount of physical activity. For instance, a fast-to-slower transition in contractile myofiber characteristics has been reported in four muscles of free-range pigs compared with the conventional system [70], since the high stocking density (area per pig) in this experiment forced the animals to escape from social assaults by trotting and jumping. Similarly, rabbits housed in large pens equipped with hurlers, displayed higher proportions of type IIA fibers and (or) type I fibers at the expense of type IIB/X fibers in various muscles [57], and increased oxidative enzyme activities (citrate synthase and β -hydroxyacyl-Coenzyme A dehydrogenase) in *semimembranosus* and *biceps femoris* muscles [110], compared with confined rabbits. Cross-sectional areas of myofibers are generally not affected by indoor space area [57, 70, 109], although a moderate hypertrophy of the myofibers has been reported in *longissimus* muscle of free-range pigs [70].

Numerous investigators did not show any changes in muscle lipid and (or) glycogen contents in animals exercising indoors compared with conventional systems [96, 107, 111]. However, Dal Bosco et al. [112] reported a higher glycogen content in fast-twitch muscles of pen-housed rabbits compared with caged rabbits. Collagen properties may be not affected by rearing systems [60, 96], whereas higher amounts [60] and lower heat-solubility [60, 96] of collagen have been reported in some muscles of pen-housing animals compared with conventional reared ones.

4.2. Alternative outdoor rearing systems

Animals reared out-of-doors have a large area over which to walk, but also a diverse environment providing various stimuli for

Table I. Respective effects of endurance training, and space allowance, in- or out-of-doors, on muscle characteristics in pigs and rabbits.

Traits	Treatment		
	Endurance training	Indoor large-scale pens	Outdoor rearing
Pigs			
Myofiber types, %	→ [70] ↗ I or IIA, ↘ IIB/X [28, 70] ↗ IIX, ↘ IIB [68]	→ [70, 107] ↗ I or IIA, ↘ IIB/X [70]	→ [113, 116] ↗ IIA, ↘ IIB/X [113, 114, 117] ↘ IIB/X [115, 116]
Cross-sectional area	→ [28, 70]	→ [70, 109] ↗ [70]	→ [113, 117] ↘, ↘ (I, IIA) [113, 114]
Citrate synthase activity	→ [68, 96, 130] ↗ [68]	→ [96, 108]	→ [117] ↗ [113]
Fat content	→ [96]	→ [96, 107–109]	→ [115, 118] ↘ [113, 119, 120] ↗ [113, 116, 121]
Glycogen content, GP ^a	↗ [78]	→ [109]	→ [117, 120, 121] ↗ [113, 120, 121]
Collagen content	→ [96, 102] ↗ [96]	→ [96]	↘ [124]
Collagen heat-solubility	→ [96] ↗ (male) [96] ↘ (female) [96]	→ [96] ↘ [96]	↗ [124]
Rabbits			
Myofiber types, %		↗ I or IIA, ↘ IIB/X [57]	
Citrate synthase activity		↗ [110]	
Fat content		→ [110, 111]	→ [123] ↘ [123]
Glycogen content, GP ^a		→ [110] ↗ [112]	
Collagen content		→ [60] ↗ [60]	→ [123] ↗ [123]
Collagen heat-solubility		↘ [60]	→ [123]

^a To take into account glycogen degradation occurring during slaughter or in vivo when biopsy samples are taken, determination of glycolytic potential (GP), i.e. the sum of the main components producing lactic acid postmortem, is frequently used.

investigating behavior. More type IIA and less type IIB/X have been reported in three of five muscles studied, including *semimembranosus* and *longissimus*, in outdoor compared with indoor pigs [113, 114]. Other studies also show a lower proportion of type IIB/X in the *tibialis cranialis* mus-

cle of outdoor reared compared with indoor housed pigs, but not in the *semimembranosus* and *biceps femoris* muscles [115, 116]. Finally, pigs in a semi-outdoor housing system (free access to an outdoor area) also exhibit both a higher proportion and a larger relative area of type IIA fibers at the expense

of type IIB/X fibers in the *longissimus* muscle [117]. Muscle metabolic enzyme activities, however, seem to adapt more to cold-exposure out of doors [113] than to physical activity solely [117]. Fiber size is not [113, 117] or little affected by rearing condition, since a slight decrease in mean cross-sectional area [113] or in cross-sectional areas of type I and IIA fibers [114] have been sometimes observed in some muscles from outdoor compared with indoor pigs.

It is impossible to state a general rule on the influence of the outdoor rearing system on intramuscular fat content, because of differences in climatic conditions, space allowance, genotypes, feeding levels, and diet composition offered to the animals. For instance, the meat of free-range or organic animals contains similar [118] or less intramuscular fat levels [113, 119, 120] than the meat of indoor animals. Likewise, increased [121] or similar [117, 122] intramuscular fat levels are observed in animals of the semi-outdoor housing system compared to indoor rearing. Concerning muscle glycogen, many studies report higher stores at slaughter in outdoor or free-range pigs compared with indoor pigs for *semimembranosus* and *biceps femoris* muscles [113, 117, 119], but the results for *longissimus* muscle are more controversial [120, 121]. There are few investigations on the adaptation of collagen properties to outdoor rearing systems. Based on six different muscles, Combes et al. [123] documented that collagen content is similar or slightly higher in organic outdoor rabbits than in confined animals, however, the heat-solubility of collagen is not modified by the rearing system. On the contrary, both lower amounts and higher heat-solubility of collagen have been demonstrated in the *longissimus* muscle of semi-extensively reared pigs compared with conventional ones [124].

5. CONCLUSION

In rats, and farm animals to a lesser extent, there is considerable evidence that exercise training results in a fast-to-slower

transition in contractile myofiber characteristics, together with improved capacity for aerobic ATP generation derived from fatty acids. However, there is a threshold for induction of the adaptation process depending on exercise intensity, muscles, and gender. With these considerations in mind, modifications in myofiber characteristics are not necessarily observed in free-range animals, in- or out-of-doors, compared with confined animals. Furthermore, responses on muscle lipid content and collagen properties in outdoor free-range animals may be either similar to or opposite of those observed in endurance trained animals, since the confounding effects of exercise, ambient temperature, substrate allowance and substrate quality, may interact together. Therefore, exercise training studies are largely unsuitable to predict the effects of free range rearing systems on many muscle characteristics and, in fine, on meat eating quality.

There is some evidence that pork meats of outdoor or semi-outdoor housing systems have lower ultimate pH and(or) higher drip loss [119, 121] – parameters that are generally associated with bad meat quality –, and display lower instrumental or sensory tenderness [119] compared with meats of conventional rearing systems. However, others found no important differences in meat quality between outdoor pigs and pigs confined indoors [114, 120, 122]. In rabbits, meat pH is lower in indoor pen-housing systems compared with conventional cages [111, 112], whereas ultimate pH is higher and loin meat tenderness is improved in organic rabbits raised outdoors compared with conventional indoor animals [123, 125]. There is no standard alternative system for pig or rabbit production. Thus, generalizations about muscle properties and meat quality from alternative rearing must be approached with great care.

REFERENCES

- [1] Purslow PP. Strain-induced reorientation of an intramuscular connective tissue network: implication for passive elasticity. *J Biochem* 1989, 22: 22–31.

- [2] Chang KC, da Costa N, Blackley R, Southwood O, Evans G, Plastow G, Wood JD, Richardson RI. Relationships of myosin heavy chain fiber types to meat quality traits in traditional and modern pigs. *Meat Sci* 2003, 64: 93–103.
- [3] Karlsson A, Enfält AC, Essen-Gustavsson B, Lundström K, Rydhmer L, Stern S. Muscle histochemical and biochemical properties in relation to meat quality during selection for increased lean tissue growth rate in pigs. *J Anim Sci* 1993, 71: 930–938.
- [4] Maltin CA, Warkup CC, Matthews KR, Grant CM, Porter AD, Delday MI. Pig muscle fiber characteristics as a source of variation in eating quality. *Meat Sci* 1997, 47: 237–248.
- [5] Lepetit J, Grajales A, Favier R. Modelling the effect of sarcomere length on collagen thermal shortening in cooked meat: consequence on meat toughness. *Meat Sci* 2000, 54: 239–250.
- [6] Purslow PP. The intramuscular connective tissue matrix and cell/matrix interactions in relation to meat toughness. In: *Proc 45th Int Congress Meat Sci Tech (IcoMST)*, 1999, p 210–219.
- [7] Avery NC, Sims TJ, Warkup C, Bailey AJ. Collagen cross-linking in porcine *M. longissimus lumborum*: absence of a relationship with variation in texture at pork weight. *Meat Sci* 1996, 42: 355–369.
- [8] Boutten B, Brazier M, Morche N, Morel A, Vendevre JL. Effects of animal and muscle characteristics on collagen and consequences for ham production. *Meat Sci* 2000, 55: 233–238.
- [9] Maltin CA, Delday MI, Sinclair KD, Steven J, Sneddon AA. Impact of manipulations of myogenesis in utero on the performance of adult skeletal muscle. *Reproduction* 2001, 122: 359–374.
- [10] Rehfeldt C, Fiedler I, Dietl G, Ender K. Myogenesis and postnatal skeletal muscle growth as influenced by selection. *Livest Prod Sci* 2000, 66: 177–188.
- [11] Rehfeldt C, Kuhn G, Vanselow J, Furbass R, Fiedler I, Nurnberg G, Clelland AK, Stickland NC, Ender K. Maternal treatment with somatotropin during early gestation affects basic events of myogenesis in pigs. *Cell Tissue Res* 2001, 306: 429–440.
- [12] Bailey AJ, Light ND. The effect of ante- and post-mortem factors on meat connective tissue: growth rate, handling and conditioning. In: *Connective tissue in meat and meat products*, Elsevier Applied Science, London, 1989, p 195–224.
- [13] Nishimura T, Ojima K, Liu A, Hattori A, Takahashi K. Structural changes in the intramuscular connective tissue during development of bovine semitendinosus muscle. *Tissue Cell* 1996, 28: 527–536.
- [14] Kovanen V. Effects of aging and physical training on rat skeletal muscle. An experimental study on the properties of collagen, laminin, and fiber types in muscles serving different functions. *Acta Physiol Scand* 1989, 577 (Suppl): 1–56.
- [15] Pette D, Vrbova G. Adaptation of mammalian skeletal muscle fibers to chronic electrical stimulation. *Rev Physiol Biochem Pharmacol* 1992, 120: 116–202.
- [16] Rainelli P. L'image de la viande de porc en France. *Attitude des consommateurs*. *Courrier Environ INRA* 2001, 42: 47–60.
- [17] Brooke MH, Kaiser KK. Muscle fiber types: how many and what kind? *Arch Neurol* 1970, 23: 369–379.
- [18] Schiaffino S, Gorza L, Sartor S, Saggin L, Ausoni S, Vianello M, Gundersen K, Lomo T. Three myosin heavy chain isoforms in type 2 skeletal muscle fibers. *J Muscle Res Cell Motil* 1989, 10: 197–205.
- [19] Hämaläinen N, Pette D. Patterns of myosin isoforms in mammalian skeletal muscle fibers. *Microscopy Res Techn* 1995, 30: 381–389.
- [20] Lefaucheur L, Ecolan P, Plantard L, Gueguen N. New insights into muscle fiber types in the pig. *J Histochem Cytochem* 2002, 50: 719–730.
- [21] Bottinelli R, Reggiani C. Human skeletal muscle fibres: molecular and functional diversity. *Prog Biophys Mol Biol* 2000, 73: 195–262.
- [22] Reichmann H, Pette D. A comparative microphotometric study of succinate dehydrogenase activity levels in type I, IIA and IIB fibers of mammalian and human muscles. *Histochem* 1982, 74: 27–41.
- [23] Jackman MR, Willis WT. Characteristics of mitochondria isolated from type I and type IIB skeletal muscle. *Am J Physiol* 1996, 270: C673–C678.
- [24] Hämaläinen N, Pette D. The histochemical profiles of fast fiber types IIB, IID and IIA in skeletal muscles of mouse, rat and rabbit. *J Histochem Cytochem* 1993, 41: 733–743.
- [25] Wakata N., Kawamura Y., Kobayashi M., Araki Y., Kinoshita M. Histochemical and biochemical studies on the red and white muscle in rabbit. *Comp Biochem Physiol B* 1990, 97: 543–545.

- [26] Peter JB, Barnard RJ, Edgerton VR, Gillespie CA, Stempel KE. Metabolic profiles of three fiber types of skeletal muscle in guinea pigs and rabbits. *Biochemistry* 1972, 11: 2627–2633.
- [27] Conjard A, Peuker H, Pette D. Energy state and myosin heavy chain isoforms in single fibers of normal and transforming rabbit muscles. *Pflügers Arch – Eur J Physiol* 1998, 436: 962–969.
- [28] Uhrin P, Liptaj T. Effect of training on fiber composition and phosphate metabolites in rest measured in vitro in muscles of young pigs. *Comp Biochem Physiol B* 1992, 102: 397–401.
- [29] Hultman E. Fuel selection, muscle fibre. *Proc Nutr Soc* 1995, 54: 107–121.
- [30] Randle PJ. Regulatory interactions between lipids and carbohydrates: the glucose fatty acid cycle after 35 years. *Diabetes Metab Rev* 1998, 14: 263–283.
- [31] Gondret F, Damon M, Jadhao SB, Houdebine LM, Herpin P, Hocquette JF. Age-related changes in glucose utilization and fatty acid oxidation. *J Muscle Res Cell Motil* 2004, 25: 405–410.
- [32] Herpin P, Vincent A, Fillaut M, Piterira B, Hocquette JF. Mitochondrial and peroxisomal fatty acid oxidation capacities increase in the skeletal muscles of young pigs during early postnatal development but are not affected by cold stress. *Reprod Nutr Dev* 2003, 43: 155–166.
- [33] Fernandez X, Tornberg E. A review of the causes of variation in muscle glycogen content and meat ultimate pH in pigs. *J Muscle Foods* 1991, 2: 209–235.
- [34] Alasnier C, Réminon H, Gandemer G. Lipid characteristics associated with oxidative and glycolytic fibres in rabbit muscles. *Meat Sci* 1996, 43: 213–224.
- [35] Leseigneur-Meynier A, Gandemer G. Lipid composition of pork muscle in relation to the metabolic type of the fibres. *Meat Sci* 1991, 29: 229–241.
- [36] Essen-Gustavsson B, Karlsson A, Lundström K, Enfält AC. Intramuscular fat and muscle fiber lipid contents in halothane-gene-free pigs fed high or low protein diets and its relation to meat quality. *Meat Sci* 1994, 38: 269–277.
- [37] Gondret F, Mourot J, Bonneau M. Comparison of intramuscular adipose tissue cellularity in muscles differing in their lipid content and fibre type composition during rabbit growth. *Livest Prod Sci* 1998, 54: 1–10.
- [38] Gondret F, Lebreton B. Feeding intensity and dietary protein level affect adipocyte cellularity and lipogenic capacity of muscle homogenates in growing pigs, without modification of the expression of sterol regulatory element binding protein. *J Anim Sci* 2002, 80: 3184–3193.
- [39] Van der Rest M, Garrone R. Collagen family of proteins. *FASEB J* 1991, 5: 2814–2823.
- [40] Lebreton B, Listrat A, Clochefer N. Age-related changes in collagen characteristics of porcine loin and ham muscles. In: *Proc 44th Int Congress Meat Sci Tech (IcoMST)*, 1998, p 718–719.
- [41] Nakamura YN, Iwamoto H, Ono Y, Shiba N, Nishimura S, Tabata S. Relationship among collagen amount, distribution and architecture in the *M. longissimus thoracis* and *M. pectoralis profundus* from pigs. *Meat Sci* 2003, 64: 43–50.
- [42] Kovanen V, Suominen H, Heikkinen E. Collagen of slow-twitch and fast-twitch muscle fibers in different types of rat skeletal muscles. *Eur J Appl Physiol Occup Physiol* 1984, 52: 235–242.
- [43] Smith SH, Judge MD. Relationship between pyridinoline concentration and thermal stability of bovine intramuscular collagen. *J Anim Sci* 1991, 69: 1989–1993.
- [44] Zimmerman SD, McCormick RJ, Vadlamudi RK, Thomas DP. Age and training alter collagen characteristics in fast- and slow-twitch rat limb muscle. *J Appl Physiol* 1993, 75: 1670–1674.
- [45] Handel SE., Stickland NC. The growth and differentiation of porcine skeletal muscle fibre types and the influence of birth weight. *J Anat* 1987, 152: 107–119.
- [46] Nougères J. Étude de l'évolution du nombre des fibres musculaires au cours de la croissance post-natale du muscle chez le lapin. *CR Soc Biol Montpellier* 1972, 166: 165–172.
- [47] Fiedler I, Wegner J, Feige KD. A growth model for fiber diameter in two muscles in the pig. *Arch Tierzucht* 1991, 34: 57–62.
- [48] Kovanen V, Suominen H, Peltonen L. Effects of aging and life-long physical training on collagen in slow and fast skeletal muscle in rats. A morphometric and immuno-histochemical study. *Cell Tissue Res* 1987, 248: 247–255.
- [49] Nougères J. Étude histologique de la croissance postnatale des muscles *soleus* et *acessorius latissimi dorsi* chez le lapin commun. *Ann Biol Anim Biophys* 1973, 17: 799–806.

- [50] Gondret F, Lefaucheur L, d'Albis A, Bonneau M. Myosin isoform transitions in four rabbit muscles during postnatal growth. *J Muscle Res Cell Motility* 1996, 17: 657–667.
- [51] McKoy G, Leger ME, Bacou F, Goldspink G. Differential expression of myosin heavy chain mRNA and protein isoforms in four functionally diverse rabbit skeletal muscles during pre- and post-natal development. *Dev Dyn* 1998, 211: 193–203.
- [52] Bacou F, Vigneron P. Évolution périnatale des voies métaboliques glycolytiques et oxydatives de divers types de muscles squelettiques du lapin et du poulet. *Ann Biol Anim Bioch Biophys* 1976, 16: 675–686.
- [53] Briand M, Boissonnet G, Laplace-Marieze V, Briand Y. Metabolic and contractile differentiation of rabbit muscles during growth. *Int J Biochem* 1993, 25: 1881–1887.
- [54] Lefaucheur L, Vigneron P. Postnatal changes in some histochemical and enzymatic characteristics of three pig muscles. *Meat Sci* 1986, 16: 199–216.
- [55] Salomon FV, Michel G, Gruschwitz F. Development of fiber type composition and fiber diameter in the *longissimus* muscle of the domestic pig (*Sus scrofa domestica*). *Anat Anz* 1983, 154: 69–79.
- [56] Hauser N, Mourou J, de Clerq L, Renart C, Remacle C. The cellularity of developing adipose tissue in Piétrain and Meishan pigs. *Reprod Nutr Dev* 1997, 37: 617–626.
- [57] Ducomps C. Adaptations fonctionnelles du muscle squelettique à l'exercice de haute intensité: effets sur le collagène, les propriétés mécaniques passives et la distribution des fibres musculaires. PhD thesis, University Paul Sabatier Toulouse III, 2002.
- [58] Kovanen V, Suominen H. Effects of age and life-time physical training on fiber composition of slow and fast skeletal muscles in rats. *Pflügers Arch* 1987, 408: 543–551.
- [59] Andersen MK, Caperna TJ, McCormick RJ. Porcine somatotropin (pST) alters intramuscular collagen cross-linking of growing pigs. *FASEB J* 1992, 6: A1942.
- [60] Ducomps C, Doutreloux JP, Darche B, Combes S, Lebas F, Mauriège P. Effects of jump training on passive mechanical stress and stiffness in rabbit skeletal muscle: role of collagen. *Acta Physiol Scand* 2003, 178: 215–224.
- [61] Kovanen V, Suominen H. Age- and training-related changes in the collagen metabolism of skeletal muscle. *Eur J Appl Physiol Occup Physiol* 1989, 58: 765–771.
- [62] Gosselin LE, Adams C, Cotter TA, McCormick RJ, Thomas DP. Effect of exercise training on passive stiffness in locomotor skeletal muscle: role of extracellular matrix. *J Appl Physiol* 1998, 85: 1011–1016.
- [63] Fang SH, Nishimura T, Takahashi K. Relationship between development of intramuscular connective tissue and toughness of pork during growth of pigs. *J Anim Sci* 1999, 77: 120–130.
- [64] Nakano T, Thompson JR, Aberne FX. Concentration of the collagen crosslink pyridinoline in porcine skeletal muscle *epipygium*. *Can Inst Food Sci Technol J* 1985, 18: 100–105.
- [65] Armstrong RB, Delp MD, Goljan EF, Laughlin MH. Progressive elevations in muscle blood flow during prolonged exercise in swine. *J Appl Physiol* 1987, 63: 285–291.
- [66] Musch TI, Poole DC. Blood flow response to treadmill running in the rat *spinotrapezius* muscle. *Am J Physiol* 1996, 271: H2730–H2734.
- [67] Perhonen M, Takala TE, Kovanen V. Effects of prolonged exposure to and physical training in hypobaric conditions on skeletal muscle morphology and metabolic enzymes in rats. *Pflügers Arch* 1996, 432: 50–58.
- [68] McAllister RM, Reiter BL, Amann JF, Laughlin MH. Skeletal muscle biochemical adaptations to exercise training in miniature swine. *J Appl Physiol* 1997, 82: 1862–1868.
- [69] Essen-Gustavsson B, Lindholm A. Influence of exercise on muscle metabolic characteristics in pigs and backfat thickness at slaughter. In: *Proc 5th Intern Conf Production Disease in Farm Animals*, 1983, p 356–362.
- [70] Petersen JS, Henckel P, Oksbjerg N, Sorensen MT. Adaptations in muscle fiber characteristics induced by physical activity in pigs. *Anim Sci* 1998, 66: 733–740.
- [71] Green HJ, Klug GA, Reichmann H, Seedorf U, Wiehrer W, Pette D. Exercise-induced fibre type transitions with regard to myosin, parvalbumin, and sarcoplasmic reticulum in muscles of the rat. *Pflügers Arch* 1984, 400: 432–438.
- [72] Jaschinski F, Schuler M, Peuker H, Pette D. Changes in myosin heavy chain mRNA and protein isoforms of rat muscle during forced contractile activity. *Am J Physiol* 1998, 274: C365–C370.

- [73] McKoy G, Ashley W, Mander J, Yang SY, Williams N, Russell B, Goldspink G. Expression of insulin growth factor-1 splice variants and structural genes in rabbit skeletal muscle induced by stretch and stimulation. *J Physiol* 1999, 516: 583–592.
- [74] Schuler M, Pette D. Fiber transformation and replacement in low-frequency stimulated rabbit fast-twitch muscles. *Cell Tissue Res* 1996, 285: 297–303.
- [75] Schmitt B, Fluck M, Decombaz J, Kreis R, Boesch C, Wittwer M, Graber F, Vogt M, Howald H, Hoppeler H. Transcriptional adaptations of lipid metabolism in *tibialis anterior* muscle of endurance-trained athletes. *Physiol Genomics* 2003, 15: 148–157.
- [76] Wu H, Gallardo T, Olson EN, Williams RS, Shohet RV. Transcriptional analysis of mouse skeletal myofiber diversity and adaptation to endurance exercise. *J Muscle Res Cell Motil* 2003, 24: 587–592.
- [77] Tikkanen HO, Naveri HK, Harkonen MH. Alteration of regulatory enzyme activities in fast-twitch and slow-twitch muscles and muscle fibres in low-intensity endurance-trained rats. *Eur J Appl Physiol Occup Physiol* 1995, 70: 281–287.
- [78] Essen-Gustavsson B, Lundström K, Larsson G, Lindholm A, Nordin AC, Hansson I, Tornberg E. The effect during growth of moderate exercise on muscle metabolic characteristics in vivo and relation to meat quality and sensory properties. In: *Proc 34th Int Congress Meat Sci Tech (IcoMST)*, 1988, p 27–30.
- [79] Holloszy JO, Coyle EF. Adaptations of skeletal muscle to endurance exercise and their metabolic consequences. *J Appl Physiol*. 1984, 56: 831–838.
- [80] Bonen A, Dyck DJ, Ibrahim A, Abumrad NA. Muscle contractile activity increases fatty acid metabolism and transport and FAT/CD36. *Am J Physiol* 1999, 276: E642–E649.
- [81] Luiken JJ, Han XX, Dyck DJ, Bonen A. Coordinately regulated expression of FAT/CD36 and FACS1 in rat skeletal muscle. *Mol Cell Biochem* 2001, 223: 61–69.
- [82] Jeukendrup AE, Saris WH, Wagenmakers AJ. Fat metabolism during exercise: a review. Part I: fatty acid mobilization and muscle metabolism. *Int J Sports Med* 1998, 19: 231–244.
- [83] Smekal G, von Duvillard SP, Pokan R, Tschan H, Baron R, Hofmann P, Wonisch M, Bachtl N. Effect of endurance training on muscle fat metabolism during prolonged exercise: agreements and disagreements. *Nutrition* 2003, 19: 891–900.
- [84] Havel RJ, Pernow B, Jones NL. Uptake and release of free fatty acids and other metabolites in the legs of exercising men. *J Appl Physiol* 1967, 23: 90–99.
- [85] Romijn JA, Coyle EF, Sidossis LS, Gastaldelli A, Horowitz JF, Endert E, Wolfe RR. Regulation of endogenous fat and carbohydrate metabolism in relation to exercise intensity and duration. *Am J Physiology* 1993, 265: E380–E391.
- [86] Langfort J, Ploug T, Ihlemann J, Holm C, Galbo H. Stimulation of hormone-sensitive lipase activity by contractions in rat skeletal muscle. *Biochem J* 2000, 351: 207–214.
- [87] Oscari LB, Essig DA, Palmer WK. Lipase regulation of muscle triglyceride hydrolysis. *J Appl Physiol* 1990, 69: 1571–1577.
- [88] Brechtel K, Niess AM, Machann J, Rett K, Schick F, Claussen CD, Dickhuth HH, Haering HU, Jacob S. Utilisation of intramyocellular lipids (IMCLs) during exercise as assessed by proton magnetic resonance spectroscopy (1H-MRS). *Horm Metab Res* 2001, 33: 63–66.
- [89] Decombaz J, Schmitt B, Ith M, Decarli B, Diem P, Kreis R, Hoppeler H, Boesch C. Post-exercise fat intake repletes intramyocellular lipids but no faster in trained than in sedentary subjects. *Am J Physiol Regul Integr Comp Physiol* 2001, 281: R760–R769.
- [90] Larson-Meyer D, Newcomer BR, Hunter GR. Influence of endurance running and recovery diet on intramyocellular lipid content in women: a H-NMR study. *Am J Physiol Endocrinol Metab* 2002, 282: E95–E106.
- [91] Borensztajn J, Rone MS, Babirak SP, McGarr JA, Oscari LB. Effect of exercise on lipoprotein lipase activity in rat heart and skeletal muscle. *Am J Physiol* 1975, 229: 394–397.
- [92] Ikeda S, Miyazaki H, Nakatani T, Kai Y, Kamei Y, Miura S, Tsuboyama-Kasaoka N, Ezaki O. Up-regulation of SREBP-1c and lipogenic genes in skeletal muscles after exercise training. *Biochem Biophys Res Commun* 2002, 296: 395–400.
- [93] Wendling PS, Peters SJ, Heigenhauser GJ, Spriet LL. Variability of triacylglycerol content in human skeletal muscle biopsy samples. *J Appl Physiol* 1996, 81: 1150–1155.
- [94] Howald H, Boesch C, Kreis R, Matter S, Billeter R, Essen-Gustavsson B, Hoppeler H. Content of intramyocellular lipids derived by electron microscopy, biochemical assays, and (1)H-MR spectroscopy. *J Appl Physiol* 2002, 92: 2264–2272.

- [95] Decombaz J, Fleith M, Hoppeler H, Kreis R, Boesch C. Effect of diet on the replenishment of intramyocellular lipids after exercise. *Eur J Nutr* 2000, 39: 244–247.
- [96] Petersen JS, Berge P, Henckel P, Sorensen MT. Collagen characteristics and meat texture of pigs exposed to different levels of physical activity. *J Muscle Food* 1997, 8: 47–61.
- [97] Staron RS, Hikida RS, Hagerman FC, Dudley GA and Murray TF. Human skeletal muscle fiber type adaptability to various workloads. *J Histochem Cytochem* 1984, 32: 146–152.
- [98] Green HJ, Reichmann H, Pette D. Fibre type specific transformations in the enzyme activity pattern of rat *vastus lateralis* muscle by prolonged endurance training. *Pflügers Arch* 1983, 399: 216–222.
- [99] Szabo A, Romvari R, Bogner P, Febel H, Szendro Z. Metabolic changes induced by regular submaximal aerobic exercise in meat-type rabbits. *Acta Vet Hung* 2003, 51: 503–512.
- [100] Meng H, Pierce GN. Metabolic and physiological response of the rabbit to continuous and intermittent treadmill exercise. *Can J Physiol Pharmacol* 1990, 68: 856–862.
- [101] Bastien C, Sanchez J. Phosphagenes and glycogen content in skeletal muscles after treadmill training in young and old rats. *Eur J Physiol* 1984, 52: 291–295.
- [102] Hawrysh ZJ, Murray DM, Bowland JP. Effects of exercise on palatability and cooking characteristics of pork. *Can J Anim Sci* 1974, 54: 191–195.
- [103] Kovanen V, Suominen H, Heikkinen E. Connective tissue of fast and slow skeletal muscle in rats- effects of endurance training. *Acta Physiol Scand* 1980, 108: 1373–1380.
- [104] Kovanen V, Suominen H, Heikkinen E. Mechanical properties of fast and slow skeletal muscle with special reference to collagen and endurance training. *J Biomech* 1984, 17: 725–735.
- [105] Koskinen SOA, Wang W, Ahtikoski AM, Kjaer M, Han XY, Komulainen J, Kovanen V, Takala TES. Acute exercise induced changes in rat skeletal muscle mRNAs and proteins regulating type IV collagen content. *Am J Physiol* 2001, 280: R1292–R1300.
- [106] Suominen H, Kiiskinen A, Heikkinen E. Effects of physical training on metabolism of connective tissues in young mice. *Acta Physiol Scand* 1980, 108: 17–22.
- [107] Gentry JG, McGlone JJ, Blanton JR, Miller MF. Impact of spontaneous exercise on performance, meat quality and muscle fiber characteristics of growing/finishing pigs. *J Anim Sci* 2002, 80: 2833–2939.
- [108] Enfält AC, Lundström K, Hansson I, Karlsson A, Essen-Gustavsson B, Hakansson J. Moderate indoor exercise: effect on production and carcass traits, muscle enzyme activities and meat quality in pigs. *Anim Prod* 1993, 57: 127–135.
- [109] Lewis PK, Rakes LY, Brown CJ, Noland PR. Effect of exercise and pre-slaughter stress on pork muscle characteristics. *Meat Sci* 1989, 26: 121–129.
- [110] Gondret F, El Ramouz R, Fernandez X, Combes S. Influence de l'exercice physique au cours de l'engraissement sur le métabolisme musculaire chez le lapin. *Viandes Prod. Carnés, Proc 10^e Journ Sci Muscle Techn Viandes* 2004, p 35–36.
- [111] Dal Bosco A., Castellini C., and Mugnai C. Rearing rabbits on a wire net floor or straw litter: behaviour, growth and meat qualitative traits. *Livest Prod Sci* 2002, 75: 149–156.
- [112] Dal Bosco A, Castellini C, Mugnai C. Effect of rearing system (cage or pen) on post-mortem evolution of pH and qualitative traits of rabbit meat. In: ITAVI (Ed), *Proc 9th Journ Rech Cunicole*, 2001, p 35–38.
- [113] Bee G, Guex G, Herzog W. Free-range rearing of pigs during the winter: adaptations in muscle fiber characteristics and effects on adipose tissue composition and meat quality. *J Anim Sci* 2004, 82: 1206–1218.
- [114] Gentry JG, McGlone JJ, Miller MF, Blanton JR. Environmental effects on pig performance, meat quality, and muscle characteristics. *J Anim Sci* 2004, 82: 209–217.
- [115] Andrés AI, Ruiz J, Ventanas J., Tejada AF, Mayoral AI. Muscle fibre type in Iberian pigs: influence of crossbreeding with Duroc breed and rearing conditions. *Ann Zoot* 1999, 48: 397–406.
- [116] Andrés AI, Cava R, Mayoral AI, Tejada AF, Morcuende D, Ruiz J. Oxidative stability and fatty acid composition of pig muscles as affected by rearing system, crossbreeding and metabolic type of muscle fiber. *Meat Sci* 2001, 59: 39–47.
- [117] Lebret B, Massabie P, Granier R, Juin H, Mourot J, Chevillon P. Influence of outdoor rearing and indoor temperature on growth performance, carcass, adipose tissue and muscle traits in pigs, and on the technological and eating quality of dry-cured hams. *Meat Sci* 2002, 62: 447–455.

- [118] Sather AP, Jones SDM, Schaefer AL, Colyn J, Roberston WM. Feedlot performance, carcass composition and meat quality of free-range reared pigs. *Can J Anim Sci* 1997, 77: 225–235.
- [119] Enfält AC, Lundström K, Hansson I, Lundeheim N, Nyström PE. Effects of outdoor rearing and sire breed (Duroc or Yorkshire) on carcass composition and sensory and technological meat quality. *Meat Sci* 1997, 45: 1–15.
- [120] Olsson V, Andersson K, Hansson I, Lundström K. Differences in meat quality between organically and conventionally produced pigs. *Meat Sci* 2003, 64: 287–297.
- [121] Lebret B, Couvreur S, Dourmad JY, Meunier-Salaun MC, Guingand N, Robin P, Hassouna M, Cariolet R. Influence of husbandry method on animal welfare and meat quality traits in pigs. *J Rech Porcine* 2004, 36: 53–62.
- [122] Van der Wal PG, Mateman G, De Vries AW, Vonder MA, Smulders FJM, Geesink GH, Engel B. “Scharrel” (free range) pigs: carcass composition, meat quality and taste-panel studies. *Meat Sci* 1993, 34: 27–37.
- [123] Combes S, Lebas F, Lebret L, Martin T, Jehl N, Cauquil L, Darce B, Corboeuf MA. Comparison between organic and standard rabbit breeding system: carcass traits and chemical composition of 6 muscles from the leg. In: ITAVI (Ed), Proc 10th Journ Rech Cunicole, 2003, p 133–136.
- [124] Berge P, Touraille C, Boccard R, Fournier R, Bayle MC. Pork quality as affected by animal age and lean colour. In: Proc 37th Int Congress Meat Sci Tech (IcoMST), 1991, p 52–55.
- [125] Combes S, Lebas F, Juin H, Lebret L, Martin T, Jehl N, Cauquil L, Darce B, Corboeuf MA. Comparison between organic and standard breeding system: sensory analysis and mechanical toughness of meat. In: ITAVI (Ed), Proc 10th Journ Rech Cunicole, 2003, p 137–140.
- [126] Gilka J, Hornich M. The colour of some rabbit muscles and the content of connective tissue. *Zivocisna Vyroba* 1975, 20: 763–778.
- [127] Candek-Potokar M, Zlender B, Lefaucheur L, Bonneau M. Effects of age and/or weight at slaughter on *longissimus dorsi* muscle: Biochemical traits and sensory quality in pigs. *Meat Sci* 1998, 48: 287–300.
- [128] Candek-Potokar M, Lefaucheur L, Zlender B, Bonneau M. Effect of slaughter weight and/or age on histological characteristics of pig *longissimus dorsi* muscle as related to meat quality. *Meat Sci* 1999, 52: 195–203.
- [129] Palanska O, Zelnick J, Gazo M, Palenik S. A study of the physical, chemical and biochemical properties of the skeletal musculature of the domestic rabbit (*Oryctolagus cuniculus*) during the course of post-natal development. *Fleischwirtsch* 1981, 61: 266–268.
- [130] Fitts RH, Cassens RG, Kauffman RG. Characteristics of skeletal muscle fiber types in the miniature pigs and the effects of training. *Can J Physiol Pharmacol* 1973; 51: 825–831.
- [131] Glatz JFC, Schaap FG, Binas B, Bonen A, van der Vuss GJ, Luiken JJFP. Cytoplasmic fatty acid-binding protein facilitates fatty acid utilization by skeletal muscle. *Acta Physiol Scand* 2003, 178: 367–371.
- [132] Stahl A. A current review of fatty acid transport proteins. *Pflügers Archiv* 2004, 447: 722–727.