



**HAL**  
open science

## Molecular confirmation of a fourth lineage in honeybees from the Near East

Pierre Franck, Lionel Garnery, Michel Solignac, Jean-Marie Cornuet

► **To cite this version:**

Pierre Franck, Lionel Garnery, Michel Solignac, Jean-Marie Cornuet. Molecular confirmation of a fourth lineage in honeybees from the Near East. *Apidologie*, 2000, 31 (2), pp.167-180. 10.1051/apido:2000114 . hal-00891704

**HAL Id: hal-00891704**

**<https://hal.science/hal-00891704>**

Submitted on 11 May 2020

**HAL** is a multi-disciplinary open access archive for the deposit and dissemination of scientific research documents, whether they are published or not. The documents may come from teaching and research institutions in France or abroad, or from public or private research centers.

L'archive ouverte pluridisciplinaire **HAL**, est destinée au dépôt et à la diffusion de documents scientifiques de niveau recherche, publiés ou non, émanant des établissements d'enseignement et de recherche français ou étrangers, des laboratoires publics ou privés.

Original article

## Molecular confirmation of a fourth lineage in honeybees from the Near East

Pierre FRANCK<sup>a</sup>, Lionel GARNERY<sup>b</sup>, Michel SOLIGNAC<sup>b</sup>,  
Jean-Marie CORNUET<sup>a\*</sup>

<sup>a</sup> Laboratoire de Modélisation et Biologie Evolutive, URLB-INRA,  
488 rue Croix de Lavit, 34090 Montpellier, France

<sup>b</sup> Laboratoire Population, Génétique et Évolution, CNRS, Gif-sur-Yvette, France

(Invited paper)

**Abstract** – The mitochondrial DNA (mtDNA) from 75 honeybee colonies from the Lebanon was characterized by *Dra*I restriction fragment length polymorphism (RFLP) of the COI-COII intergenic region. The seven observed haplotypes were different enough from all haplotypes already known in *Apis mellifera* to justify their assignment to a fourth mtDNA lineage. The nucleotide sequence of a 380 base pair (bp) fragment of the NADH2 gene was determined for two haplotypes, which showed a high similarity with two published sequences from *A. m. lamarkii* and *A. m. meda*. A microsatellite analysis of a large Lebanese population sample (50 colonies, 8 loci) suggests that Near East populations are also differentiated at the nuclear level from the three previously characterized evolutionary branches of the species *A. mellifera*.

*Apis mellifera* / mtDNA / microsatellite / evolutionary history / Near East

### 1. INTRODUCTION

The evolutionary history of the species *Apis mellifera* was first addressed on morphometric grounds. Based on a multivariate analysis of an extensive set of samples, Ruttner et al. [30] proposed the first scenario in 1978. This hypothesis was long

considered the standard in the field. According to these authors, the western honeybee originated in Asia and invaded Africa and Europe in three distinct evolutionary branches, a South and Central African branch (A), a North African and West European branch (M) and a North Mediterranean branch (C). This scenario was further refined

---

\* Correspondence and reprints  
E-mail: cornuet@ensam.inra.fr

by the addition of a fourth evolutionary branch, called O, which included the Near and Middle Eastern subspecies (*anatoliaca*, *adami*, *cyprica*, *syriaca*, *meda*, *caucasica* and *armeniaca*) [29]. This scenario received support from several morphometrical studies performed on local populations of West European and North African subspecies [5–7, 25].

Morphological characters are not well suited to phylogeographical studies because they can be sensitive to environmental selection pressures. In that respect, mitochondrial DNA (mtDNA) is a much better genetic marker [2]. The first studies on mtDNA variation globally agreed with Ruttner's scenario [4, 16, 31, 32] in that they showed the existence of three mitochondrial lineages corresponding roughly to three of the evolutionary branches (A, M and C). These three evolutionary branches were also supported by a microsatellite analysis of nine populations belonging to seven different subspecies from Europe and Africa [11]. The main difference provided by molecular markers was the inclusion of North African subspecies (*A. m. intermissa* and *sahariensis*) in the African branch instead of the West European branch [16]. The first clue to a possible fourth lineage was the deep branching of an Egyptian sample in a general phylogenetic tree of mtDNA haplotypes from many subspecies of honeybees [31]. Note that in Ruttner's classification [29, 30], the Egyptian geographic race, *A. m. lamarkii*, was included in the branch A and not in the branch M. A second and more convincing clue to a fourth lineage was given by Arias and Sheppard who sequenced approximately 700 base pairs (bp) in the NADH dehydrogenase 2 region of the mtDNA from 14 different honeybee subspecies [1]. Two sequences, one common to two *lamarkii* colonies from Assiout (Egypt) and the other from a single *meda* colony from Latakya (Mediterranean coast of Syria) clustered together and away from all other sequences, supporting the hypothesis of a fourth lineage. Note also here that

the sequence of a second *meda* colony (located a few hundred kilometers eastward from the former) unambiguously belonged to lineage C. Another subspecies considered by Ruttner as a member of branch O is *A. m. anatoliaca* which is distributed over most of the Turkish territory and comes into contact with *meda* in South Eastern Turkey. A survey of Turkish colonies showed that all of them also had mtDNA haplotypes belonging to lineage C [33] (see also [23] for isozyme analysis). A similar conclusion had already been reached from samples of the subspecies *caucasica* [16, 31].

Considering the very small number of colonies supporting the hypothesis of a fourth mtDNA lineage and their scattered and rather unexpected geographical distribution, further studies were needed to answer the following questions: i) how real is this putative fourth mtDNA lineage; and ii) if definite proof of its existence can be given, how does it relate to Ruttner's branch O? In this paper, we analyzed the mtDNA variation of 75 Lebanese colonies (subspecies *syriaca*) with a test previously shown to be powerful in various honeybee population surveys [13, 18–20]. This test consists of analyzing the COI-COII intergenic region which is composed of a varying number of two basic sequences named P/Po and Q [8]. The sequence P discriminates among the three mitochondrial lineages: it is absent in lineage C, contains 54–56 bp in lineage M (sequence P) and 62–69 bp in lineage A (sequence Po). Lineage C haplotypes contain a single sequence Q (192–193 bp), whereas lineages A and M haplotypes can contain from one up to four sequences Q (192–196 bp). In addition, there is a variation revealed by *DraI* restriction fragment length polymorphism (RFLP), mainly in lineages A and M, resulting in more than 50 different haplotypes known so far.

We also characterized a Lebanese population with eight microsatellite loci. The congruence between mitochondrial lineages and evolutionary branches (based on

characters under nuclear genetic determinism) has been shown to be partial on several occasions [13, 14]. For instance in the Iberian peninsula, where a variable mixture of lineages A and M haplotypes exists in a pure M nuclear genetic background, we found a Portuguese population sample with a pure lineage A mtDNA [13]. It is then essential to check the congruence of mitochondrial and nuclear based information, and microsatellites are among the best markers for that purpose [10].

## 2. MATERIALS AND METHODS

### 2.1. Sampling and DNA extraction

A total sample of 75 honeybees, each representing a different colony, was collected in the Lebanon. This total sample was composed of 50 honeybees representing a single population from El-Hermel (Northern Lebanon) and 25 honeybees from various locations dispersed over Beirut. Honeybees were individually placed in 1.5-mL Eppendorf tubes containing 1 mL of 95% ethanol for transportation to the laboratory. Total DNA was extracted from one leg with a chelex-based protocol [12].

Nine additional populations from Malawi (Chelinda, *A. m. monticola*, branch A), South Africa (Pretoria, *A. m. scutellata*, branch A), Guinea (Nimba, *A. m. adansonii*, branch A), Morocco (Al-Hoceima, *A. m. major*, branch A), France (Valenciennes, *A. m. mellifera*, branch M), Sweden (Umeo, *A. m. mellifera*, branch M), Spain (Toledo, *A. m. iberica*, branch M), Italy (Forli, *A. m. ligustica*, branch C), and Greece (Chalkidiki, *A. m. macedonica*, branch C) were used for comparison (see [11, 13, 15, 18–20] for original data).

### 2.2. mtDNA

The mtDNA region including the tRNA<sup>leu</sup> gene, the COI-COII intergenic

region and the 5' end of the COII sub-unit gene was polymerase chain reaction (PCR)-amplified according to a protocol detailed elsewhere [17]. A fraction of the PCR product was run on a 1% agarose gel for total size determination and the remaining fraction was restricted with *DraI* prior to electrophoresis on 7.5% polyacrylamide gel. Among the newly found haplotypes, some, corresponding to the most frequent types (70 over 75 colonies), were sequenced for further characterization (Fig. 1).

Another region located in the NADH dehydrogenase subunit 2 gene and encompassing 380 bp from position 740 to 1110 [9, 24] was also sequenced in different new haplotypes of the COI-COII region using cycle sequencing. All sequences were obtained through a standard protocol on an ABI 370 automated sequencer using *Taq* F5 and dye-labeled terminators (Perkin-Elmer).

### 2.3. Microsatellites

Eight microsatellite loci were scored: *A43*, *B124*, *A88*, *A113*, *A28*, *A24*, *A8* and *Ap43*. The protocol followed was the same as in previous studies [11, 13, 20].

### 2.4. Statistical and phylogenetic analyses

Unbiased estimates and standard deviations of gene diversity of mtDNA and microsatellite loci were calculated according to Nei and Tajima [27] and Nei [26] respectively. Exact tests for genetic structure were computed using the GENEPOP package version 3.1 [28]. Genetic differentiation between populations was computed using unbiased estimates of *F<sub>st</sub>* values provided by GENEPOP and the (d<sub>μ</sub>)<sup>2</sup> microsatellite distance [21].

Phylogenies of mitochondrial haplotypes were reconstructed using the neighbour-joining algorithm and a *P*-distance. Presence/absence of bp substitutions and insertions/deletions along the COI-COII



intergenic sequence were coded as 1/0. When a component was missing, the corresponding characters were coded as missing data (e.g., insertions/deletions and substitutions within the P sequence in lineage C). A neighbour-joining tree from population samples was calculated from microsatellite data using the chord distance of Cavalli-Sforza and Edwards [3]. Bootstrap values were computed over 2 000 replications [22], re-sampling either individuals within populations (microsatellite data) or characters (mitochondrial sequences).

### 3. RESULTS

#### 3.1. MtDNA data

All 75 Lebanese colonies were characterized by new haplotypes of the COI-COII region, which fall into seven different categories, noted as O1a, O1b, O1c, O1', O1'', O2 and O3 (Tabs. I and II). Most of these haplotypes O display a sequence P of the same length as that found in the African lineage, i.e., equivalent to sequence Po [17]. The most easily detected exception is haplotype O3 which has a 5 bp deletion in sequence Po (Fig. 1). The main difference between haplotypes O and A is the presence in the former haplotypes of an additional restriction site at position 16, yielding a 66 or 67 bp DNA fragment (Fig. 1 and Tab. II), the difference in size being due to the deletion of one base at site *i*. The haplotypes O1a, O1b and O1c differ from each

other by small insertion/deletions (1 or 2 bp) within the Po and the Q sequences, which were not easily detected using restriction (Fig. 1 and Tab. II). Haplotypes O1' and O1'' have, respectively, two and three Q sequences. The haplotype O1c was also detected (and sequenced) in one *A. m. lamarckii* colony from Assiout (Fig. 1).

A total of 66 characters provided by the sequencing of the COI-COII region were used to reconstruct a phylogeny of 17 haplotypes (Fig. 2). The resulting neighbor-joining tree unambiguously unites the haplotypes from the Lebanon and Egypt within a fourth lineage called O in reference to Ruttner [29]. All other haplotypes are clearly assigned to their previously described lineage [13]. Note that the divergence values of COI-COII sequences between lineage O and other lineages are of the same order of magnitude (2 to 3.5%) as those observed among lineages A, C and M (Tab. III).

Among the different haplotypes O, O1a and O3 were randomly chosen for ND2 sequence determination. The two ND2 sequences appeared very similar to those of group II reported by Arias and Sheppard [1]. This group II includes a colony (MEDA1) sampled at Latakya (Syria) for which the ND2 sequence is identical to that of our haplotype O1a, and another colony (LAMARC) from Assiout (Egypt) for which this sequence differs by one transition at position 1050 from that of haplotype O3.

---

**Figure 1.** Partial sequences of haplotypes of the COI-COII intergenic region. This region includes the tRNA<sup>leu</sup> gene and a non coding sequence made up of two components, P/Po and Q. Substitution sites are numbered from 1 to 27 and insertion/deletion sites are labelled from *a* to *n*. Sites *f*, 5, 9, 12, 14, 15, 18 and 27 are not variable in the eight sequences presented here and refer to sites that are variable in the whole set of known sequences. *Dra*I restriction sites are indicated in bold characters (TTTAAA). The first sequence (*A. m. syriaca*, haplotype O2) contains two tandemly repeated sequences Q. Only the first sequence Q which is characterized by a terminal deletion of 15 bp is presented in the figure. The second sequence Q of this haplotype is identical to that of haplotype O3. This second sequence Q is denoted by a star (\*) after the terminal deletion in the first sequence Q.





**Table II.** Origin, restriction lengths and variable sites of the COI-COII haplotypes used for phylogenetic analysis.

Subspecies, origin, Restriction lengths haplotype	Restriction lengths (Total sizes)	P sequences										Q sequences										COII gene																				
		1	a	b	c	d	e	f	2	3	4	5	6	7	8	9	g	h	i	j	10	11	12	13	14	k	l	15	16	m	n	17	18	19	20	21	22	23	24	25	26	27
<i>A. m. syriaca</i> , Lebanon, O2	47/108/67 <sup>2</sup> /114/420 823 <i>PoQQ</i>	A	0	0	0	0	0	0	T	A	C	A	G	A	C	A	0	0	0	0	T	A	T	A	C	+3	-1	T	A	0	-15 <sup>b</sup>	T	C	A	C <sup>b</sup>	T	C	T	T	C	G	T
<i>A. m. syriaca</i> , Lebanon, O3	47/103/67/420 637 <i>PoQ</i>	A	0	0	-5	0	0	0	T	/	C	A	G	A	C	A	0	0	0	0	T	A	T	A	C	+3	-1	T	A	0	0	T	C	A	C	T	C	T	T	C	G	T
<i>A. m. syriaca</i> , Lebanon, O1a	47/108/66/420 641 <i>PoQ</i>	A	0	0	0	0	0	0	T	A	C	A	A	A	C	A	0	0	-1	0	T	A	T	A	C	+3	-1	T	A	0	0	T	C	G	C	T	C	T	T	C	G	T
<i>A. m. syriaca</i> , Lebanon, O1b	47/110/66/420 643 <i>PoQ</i>	A	0	0	0	0	+2	0	T	A	C	A	G	A	C	A	0	0	-1	0	T	A	T	A	C	+3	-1	T	A	0	0	T	C	G	C	T	C	T	T	C	G	T
<i>A. m. lamarkii</i> , Egypt, O1c	47/108/67/420 642 <i>PoQ</i>	A	0	0	0	0	0	0	T	T	C	A	G	A	C	A	0	0	0	0	T	A	T	A	C	+3	-1	T	A	0	0	T	C	G	C	T	C	T	T	C	G	T
<i>A. m. major</i> , Morocco, A8	47/591 638 <i>PoQ</i>	A	0	0	0	0	0	0	C	A	C	A	A	A	T	A	-1	+1	-1	-1	A	A	T	G	C	0	0	T	T	0	0	C	C	G	T	C	C	T	T	T	G	T
<i>A. m. intermissa</i> , Algeria, A9	47/783 830 <i>PoQQ</i>	A	0	0	0	0	0	0	C	A	C	A	A	A	T	A	-1	+1	-1	-1	A	A	T	G	C	0	0	T	T	0	0	C	C	A	T	C	C	T	T	T	G	T
<i>A. m. scutellata</i> , Algeria, A4	47/107/191/483 828 <i>PoQQ</i>	A	0	0	0	0	0	0	C	A	C	A	A	-1 <sup>c</sup>	T	A	-1	+1 <sup>a</sup>	-1	-1	A	A	T	A	C	0	0	T	T	0	0	C	C	G	T	C	C	T	T	T	G	T
<i>A. m. iberica</i> , Spain, A1	47/108/483 838 <i>PoQQ</i>	A	0	0	0	0	0	0	C	A	C	A	A	A	T	A	-1	+1	-1	-1	A	A	T	A	C	0	0	T	T	0	0	C	C	G	T	C	C	T	T	T	G	T
<i>A. m. iberica</i> , Spain, M8	114/28/65 <sup>2</sup> /131/422 825 <i>PoQ</i>	T	0	-4	-5	-4	0	0	/	/	T	A	A	T	T	T	0	0	0	0	T	T	T	A	C	0	0	T	A	+2	0	C	C	A	T	C	C	C	T	T	G	T

mtDNA and microsatellites of Lebanese bees



**Table II.** (Continued).

<i>A. m. iberica</i> , Spain, M3	47/94/65/422 828 PQ	A 0 -4 -5 -4 0 -1 / / T A A T T A 0 0 0 0 T T T A C 0 0 T A +2 0 C C A T C C C T T G A
<i>A. m. iberica</i> , Spain, M7'	47/95/65 <sup>3</sup> /131 <sup>2</sup> /422 1021 PQQQ	A 0 -4 -5 -4 0 0 / / T A A T T A 0 0 0 0 T T T A C 0 0 T A +2 0 C C A T C C C T T G T
<i>A. m. mellifera</i> , France, M6	142/65/422 629 PQT	A 0 -4 -5 -4 0 0 / / T A A T T A 0 0 0 0 T T T A C 0 0 T A +2 0 C C A T C C T T T G T
<i>A. m. mellifera</i> , France, M4	142/65 <sup>2</sup> /131/422 825 PQQT	A 0 -4 -5 -4 0 0 / / T A A T T A 0 0 0 0 T T T A C 0 0 T A +2 0 C C A T C C T T T G T
<i>A. m. ligustica</i> , Italy, C1	47/41/64/420 572 QA	A -67 / / / / / / / / / / / / -1 +1 -1 0 T A T A C 0 0 T A 0 0 C C G T T T C C T A T
<i>A. m. carnica</i> , Croatia, C2a	47/40/64/420 571 QA	A -67 / / / / / / / / / / / / -1 0 -1 0 T A T A A 0 0 T A 0 0 C C G T C T C T T A T
<i>A. m. caucasica</i> , France, C2b	47/40/63/421 571 QA	A -67 / / / / / / / / / / / / -1 0 -1 0 T A T A C 0 0 A A 0 0 C C G T C T C T T A T

<sup>a</sup> Insertion *h* is not present in the second sequence Q; <sup>b</sup> deletion *n* is not present in the second sequence Q in which a cytosine is observed in position 20; <sup>c</sup> one bp deletion in position 7 coded as missing data for phylogenetic reconstruction.

The restriction length fragments and the total size of the PCR amplifications are indicated in base pairs (bp). The exponent number refers to the number of equal size fragments. Nucleotide information is labelled for substitution sites (numbered from 1 to 27) and insertion (+) / deletion (-) is indicated in bp (labelled from *a* to *n*) as in Figure 1. Haplotypes O1' and O1'' differ from O1a and O1c haplotypes by one additional restriction fragment of 129 bp; both 66 and 67 bp fragments are observed (see text).

### 3.2. Microsatellite data

Heterozygosity estimates at microsatellite loci in the population from El-Hermel range from 0.367 (A28) to 0.872 (A43), with an average of  $0.647 \pm 0.173$ . Allelic frequencies are available at <http://www.ensam.inra.fr/URLB>. A Fisher exact test for genic differentiation confirms the high differentiation of El-Hermel in comparison with the other nine populations at all scored microsatellite loci ( $P < 0.0017$ ). Multilocus *Fst* and  $(d\mu)^2$  values ranged from 0.141 to 0.415 and from 4.50 to 46.58 respectively in pairwise population comparisons with El-Hermel (Tab. IV). Apart from the  $(d\mu)^2$  between El-Hermel and Chalkidiki (lineage C), these values are well in the range of comparisons between lineages (Tab. IV). The neighbor-joining tree using Cavalli-Sforza and Edwards' distance between populations shows that the population from El-Hermel branches on the edge, linking populations of the evolutionary branch C to the clade of the other two branches (A and M), i.e., close to the putative root of the tree (Fig. 3).

### 4. DISCUSSION

The high genetic divergence between mitochondrial haplotypes from the Lebanon

and those of previously described lineages A, M and C provides further proof of the existence of a Near Eastern evolutionary lineage in *A. mellifera*. The high genetic differentiation at microsatellite loci between the population from El-Hermel and populations from other branches also reinforces the hypothesis of a branch O. The similarity of mitochondrial ND2 and COI-COII sequences observed between *A. m. syriaca* and a few colonies from the subspecies *A. m. lamarckii* and *A. m. meda* permits a more precise assessment of the distribution area of this new lineage.

The branch O defined by Ruttner on a morphometric basis encompasses Near and Middle Eastern subspecies *anatoliaca*, *caucasica*, *meda*, *syriaca*, *adami*, *cypria* and *armeniaca* [29]. Only the first four subspecies have been investigated with mitochondrial markers, and among them only *A. m. syriaca* displays haplotypes differing significantly from those of other lineages. *A. m. caucasica* and *A. m. anatoliaca* are clearly related to other subspecies from the branch C [16, 33]. *A. m. meda* displays two widely different mitochondrial haplotypes, one from lineage O and the other from lineage C [1]. These molecular results suggest that the lineage C extends far beyond Eastern Europe into the Northern Middle East. The northern limit of lineage O might be

**Figure 2.** Neighbor-joining tree using the *P*-distance between the COI-COII haplotypes. The trees were established for 17 haplotypes with 66 informative sites (Tab. II). A, M, O, and C refers to the four major lineages of haplotypes (see text). Bootstraps values have been computed over 2 000 iterations by resampling the variable sites.

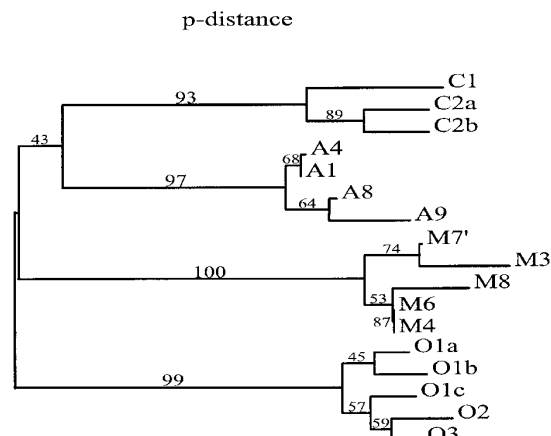

**Table III.** Ranges of sequence divergence percentage within and between lineages using the COI-COII intergenic region.

	Lineage O	Lineage A	Lineage M	Lineage C
Lineage O	0.3–0.6			
Lineage A	2.0–3.5	0.2–0.9		
Lineage M	2.4–3.0	2.2–3.0	0.3–0.8	
Lineage C	2.1–2.5	1.6–2.1	1.6–2.3	0.3–0.7

**Table IV.** Pairwise multilocus unbiased estimates of *Fst* provided by GENEPOP (below diagonal) and  $d\mu^2$  distance (above diagonal).

	Her (O)	Sev (M)	Ume (M)	Val (M)	Hoc (A)	Nim (A)	Che (A)	Pre (A)	Cha (C)	For (C)
Her (O)		<b>46.58</b>	<b>35.38</b>	<b>36.26</b>	<b>22.64</b>	<b>15.28</b>	<b>17.64</b>	<b>19.11</b>	<b>4.50</b>	<b>13.56</b>
Sev (M)	<b>0.415</b>		4.55	9.66	24.75	22.20	29.38	23.27	30.15	52.37
Ume (M)	<b>0.407</b>	0.071		9.37	14.94	12.91	17.81	12.27	43.10	54.35
Val (M)	<b>0.388</b>	0.045	0.030		20.24	18.08	26.37	17.79	41.01	43.41
Hoc (A)	<b>0.211</b>	0.276	0.267	0.250		3.81	2.42	3.20	23.62	39.23
Nim (A)	<b>0.156</b>	0.313	0.295	0.284	0.047		1.33	1.24	13.84	25.60
Che (A)	<b>0.147</b>	0.275	0.267	0.259	0.049	0.005		1.79	15.83	31.43
Pre (A)	<b>0.141</b>	0.285	0.274	0.264	0.061	0.011	0.010		17.46	30.87
Cha (C)	<b>0.214</b>	0.548	0.528	0.509	0.279	0.231	0.204	0.201		5.63
For (C)	<b>0.306</b>	0.531	0.502	0.490	0.325	0.268	0.248	0.243	0.162	

Population names are abbreviated as three underlined letters: *Seville*, *Umeo*, *Valenciennes*, *Al-Hoceima*, *Nimba*, *Chelinda*, *Pretoria*, *El-Hermel*, *Chalkidiki*, *Forli*.

within the distribution area of the subspecies *A. m. meda* where the finding of two highly diverged haplotypes suggests a possible secondary hybridization between lineages O and C. In addition, although *A. m. lamarckii* has been assigned to the branch A according to morphometry [29], limited mitochondrial data suggest that the lineage O is also present in Egypt. The lineage O would thus extend outside the Middle East into North-eastern Africa.

The accumulation of genetic changes in lineage O probably results from its isolation in the Arabian Peninsula during inferior Pleistocene glaciations. Note, however, that the Lebanese population from

El-Hermel displays a low genetic differentiation with the Greek population from Chalkidiki at microsatellite loci. The characterization of a mitochondrial lineage O is not necessarily corroborated by the identification of a branch O at nuclear level. As previously observed in Spain and Italy [13, 14], morphometry and molecular markers such as mtDNA and microsatellite loci can be non-concordant.

In conclusion, the analysis of Lebanese honeybees with molecular markers provides further evidence of a fourth lineage in *Apis mellifera*. However, the analysis of additional subspecies from the Middle East and from the Horn of Africa will certainly help

## Cavalli-Sforza and Edwards chord distance

**Figure 3.** Neighbor-joining tree using the Cavalli-Sforza and Edwards distance between populations (eight microsatellite loci). The trees were established for ten populations. A, M, O, and C refers to the four evolutionary branches in *A. mellifera*. Bootstrap values have been computed over 2 000 iterations by resampling the individuals within the populations.

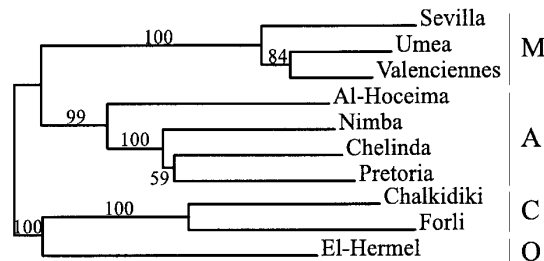

assess the distribution area of lineage O. These subspecies encompass *A. m. meda*, *A. m. caucasica*, *A. m. anatoliaca* for the Northern bounds, and *A. m. lamarckii*, *A. m. yemenitica* down to *A. m. litorea* for the Southern limits. If the above hypothesis of a past isolation of branch O in the Arabian Peninsula has any basis, the molecular characterization of *A. m. yemenitica* would be of high interest, as it might be central in the distribution area of this lineage. Both microsatellite and mitochondrial markers will be useful for the understanding of the phylogeography of the honeybee in the Middle East and to resolve relationships among lineages.

#### ACKNOWLEDGMENTS

The authors are most grateful to M. Colin, V.R. Habib, D. Azar and the association 'Apis Liban' for their helping to collect samples.

**Résumé – Confirmation sur des bases moléculaires de l'existence d'une quatrième lignée évolutive chez les abeilles domestiques du Proche Orient.** Sur la base d'une analyse morphométrique extensive, Ruttner et ses collaborateurs avaient conclu que les races d'abeilles (*Apis mellifera* L.) pouvaient être regroupées en trois grandes branches évolutives désignées respectivement par A (races du centre et du sud de

l'Afrique), M (races nord-africaines et ouest-européennes) et C (races nord-méditerranéennes). Ultérieurement, Ruttner a regroupé les races du Proche et Moyen Orient (*anatoliaca*, *adami*, *cypria*, *syriaca*, *meda*, *caucasica* et *armeniaca*) dans une quatrième branche nommée O. Les premières études avec des marqueurs moléculaires (ADN mitochondrial d'abord, microsatellites ensuite) ont globalement confirmé l'existence des trois premières branches, la principale différence étant l'inclusion des races nord-africaines dans la branche A. Cependant, dans une étude fondée sur la séquence du gène mitochondrial ND2, Arias et Shepard ont trouvé deux colonies, l'une en Egypte (*A. m. lamarckii*) et l'autre en Syrie occidentale (*A. m. meda*), divergeant suffisamment des autres échantillons pour justifier leur appartenance à une lignée différente des trois premières. Par ailleurs, des analyses de colonies turques (*A. m. anatoliaca*) et caucasiennes (*A. m. caucasica*) avaient montré que ces deux races appartenaient sans ambiguïté à la lignée C. Considérant le nombre très réduit (deux) de colonies en faveur de l'hypothèse d'une quatrième lignée évolutive chez l'abeille d'une part, et leur répartition géographique en partie inattendue d'autre part, nous avons voulu vérifier l'hypothèse de l'existence de cette lignée à partir de la caractérisation moléculaire d'un large échantillon de colonies libanaises. Cet échantillon a été constitué par 75 abeilles (représentant chacune une colonie

différente). Cinquante de ces abeilles représentent une population et proviennent de la région d'El-Hermel (Nord Liban). Les 25 autres abeilles proviennent de sites dispersés autour de Beyrouth. Huit microsattellites ont été typés sur les 50 abeilles d'El-Hermel et l'ADN mitochondrial des 75 abeilles a été caractérisé par un test rapide décrit antérieurement. Les ressemblances entre ces haplotypes et le fort niveau des différences observées avec ceux des autres lignées sont en faveur de l'hypothèse qu'ils appartiennent à une quatrième lignée. La séquence du gène ND2 dans la colonie de Syrie occidentale d'Arias et Sheppard coïncide exactement avec la séquence correspondante de l'un des sept haplotypes libanais, et celle de leur colonie égyptienne diffère par une seule base de celle d'un autre haplotype libanais. Les haplotypes libanais appartiennent donc à la même lignée mitochondriale que les colonies syrienne et égyptienne d'Arias et Sheppard, et nous la désignerons par la lettre O. Les données microsattellites indiquent une différenciation élevée de la population d'El-Hermel par rapport à un ensemble de populations de référence des trois autres lignées. En conclusion, il existe bien une quatrième branche évolutive caractérisée par une nouvelle lignée mitochondriale, mais ses limites géographiques et les races concernées diffèrent selon les types de marqueurs utilisés. Par rapport à l'hypothèse de Ruttner, les données mitochondriales indiquent une aire de distribution décalée vers le sud et empiétant sur l'Afrique du nord.

***Apis mellifera* / ADNmt / microsattelite / histoire évolutive / Proche Orient**

**Zusammenfassung – Molekulare Bestätigung eines vierten Abstammungastes bei Honigbienen im Nahen Osten.** Auf Grund einer ausführlichen morphometrischen Analyse kamen Ruttner und seine Mitarbeiter zum Schluss, dass sich die Rassen der Honigbienen in drei große evolutive Äste

gliedern, die als Ast A (Zentral- und Südafrikanische Rassen), M (Nordafrikanische und Westeuropäische Rassen) und C (Nordmediterrane Rassen) bezeichnet wurden. Später hat Ruttner die Rassen des nahen und mittleren Orients (*anatoliaca*, *adami*, *cypria*, *syriaca*, *meda*, *caucasica* und *armeniaca*) in einem 4. Zweig, dem Ast O, abgetrennt. Die ersten Studien mit molekularen Markern (zunächst mitochondriale DNA, später Mikrosatelliten) haben insgesamt die Existenz von drei Hauptästen bestätigt, wobei eine prinzipielle Differenz durch die Zugehörigkeit der Nordafrikanischen Rassen in den Ast A bestand.

Während einer Untersuchung, die sich auf die Sequenz des Gens N2 aus Mitochondrien stützt, fanden Arias und Sheppard zwei Völker, eins von Ägypten (*A. m. lamarckii*) und das andere vom westlichen Syrien (*A. m. meda*), die ausreichend deutlich von den anderen Proben abwichen, um ihre Zugehörigkeit zu einem unterschiedlichen Ast als die drei ersten zu rechtfertigen. Auf einem anderen Wege, mit Analysen von türkischen Völkern (*A. m. anatoliaca*), und kaukasischen Völkern (*A. m. caucasica*) wurde gezeigt, dass diese beiden Rassen ohne Zweifel zum Ast C gehören. Unter Anbetracht der zum einen sehr geringen Probenzahl (2), die für die Hypothese eines 4. evolutiven Astes sprach, und zum anderen wegen der nicht erwarteten geographischen Verteilung, wollten wir die Hypothese der Existenz dieses Astes mit Hilfe der molekularen Charakterisierung von einer großen Anzahl an Proben mit libanesischen Bienenvölkern verifizieren. Diese Proben bestanden aus 75 Bienen (jede entsprach einem anderen Volk). Fünfzig dieser Bienen repräsentierten eine Population und stammten aus der Region von El-Hermel (Nord Libanon). Die 25 anderen Bienen stammten aus verschiedenen Gebieten der Umgebung Beiruts. Acht Mikrosatelliten wurden bei den 50 Bienen von El-Hermel typisiert und die Variation der mitochondrialen DNA der 75 Bienen wurde durch den bereits früher beschriebenen Schnell-

test bestimmt. Die Ähnlichkeiten zwischen diesen Haplotypen und die Stärke des Niveaus der beobachteten Unterschiede zu denen der anderen Äste unterstützen die Hypothese, dass diese zu einem 4. Ast gehören. Die Sequenz des Gens ND2 vom Volk aus Westsyrien von Arias und Sheppard stimmen genau mit der Sequenz überein, die einem der sieben libanesischen Haplotypen entsprechen. Das Gen aus ihrem ägyptischen Volk unterscheidet sich nur in einer einzigen Base von dem eines anderen libanesischen Haplotypen. Demnach gehören die libanesischen Haplotypen zu demselben mitochondrialen Ast wie die syrischen und ägyptischen Völker von Arias und Sheppard und wir bezeichnen ihn mit dem Buchstaben O. Die untersuchten Mikrosatelliten zeigen eine erhöhte Differenzierung der Population von El-Hermel auf Grund der Einheitlichkeit der Referenzpopulationen der drei anderen Äste. Als Schlussfolgerung läßt sich feststellen, es gibt sicher einen 4. evolutiven Ast, der durch eine neue mitochondriale Linie charakterisiert ist. Aber seine geographischen Grenzen und die betroffenen Rassen werden entsprechend der eingesetzten Typen von Markern noch unterschiedlich eingeordnet. In Bezug auf die Hypothese von Ruttner weisen die Ergebnisse mit den Mitochondrien darauf hin, dass das Gebiet mit diesen Rassen südlich verschoben scheint und sich weiter nach Nordost-Afrika ausbreitet.

***Apis mellifera* / mtDNA / Mikrosatellit /  
Entwicklungsgeschichte / Naher Osten**

**REFERENCES**

- [1] Arias M.C., Sheppard W.S., Molecular phylogenetics of honeybee subspecies (*Apis mellifera* L.) inferred from mitochondrial DNA sequence, *Mol. Phyl. Evol.* 5 (1996) 557–566.
- [2] Avise J.C., Arnold J., Ball R.M., Intraspecific phylogeography: the mitochondrial DNA bridge between population genetics and systematics, *Annu. Rev. Ecol. Syst.* 18 (1987) 489–522.
- [3] Cavalli-Sforza L., Edwards A.W.F., Phylogenetic analysis: models and estimation procedures, *Am. J. Hum. Genet.* 19 (1967) 233–257.
- [4] Cornuet J.-M., Fresnaye J., Étude biométrique de colonies d'abeilles d'Espagne et du Portugal, *Apidologie* 20 (1989) 93–101.
- [5] Cornuet J.-M., Garnery L., Mitochondrial DNA variability in honeybees and its phylogeographic implications, *Apidologie* 22 (1991) 627–642.
- [6] Cornuet J.-M., Fresnaye J., Tassencourt L., Discrimination et classification de populations d'abeilles à partir de caractères biométriques, *Apidologie* 6 (1975) 145–187.
- [7] Cornuet J.-M., Daoudi A., Mohssine E.H., Fresnaye J., Étude biométrique de populations d'abeilles marocaines, *Apidologie* 19 (1988) 355–366.
- [8] Cornuet J.-M., Garnery L., Solignac M., Putative origin and function of the intergenic region COI and COII of *Apis mellifera* L. mitochondrial DNA, *Genetics* 128 (1991) 393–403.
- [9] Crozier R.H., Crozier Y.C., The mitochondrial genome of the honeybee *Apis mellifera*: complete sequence and genome organisation, *Genetics* 133 (1993) 97–117.
- [10] Estoup A., Cornuet J.-M., Microsatellite evolution: inferences from population data, in: Goldstein D.B., Schlötterer C. (Eds.), *Microsatellites Evolution and Applications*, Oxford Univ. Press, Oxford, 1999, pp. 49–65.
- [11] Estoup A., Garnery L., Solignac M., Cornuet J.-M., Microsatellite variation in honeybee (*Apis mellifera* L.) populations: hierarchical genetic structure and test of the infinite allele and stepwise mutation models, *Genetics* 140 (1995) 679–695.
- [12] Estoup A., Largiadèr C.R., Perrot E., Chourrout D., Rapid one-tube DNA extraction for reliable PCR detection of fish polymorphic markers and transgenes, *Mol. Mar. Biol. Biotechnol.* 5 (1996) 295–298.
- [13] Franck P., Garnery L., Solignac M., Cornuet J.-M., The origin of west European subspecies of honeybees (*Apis mellifera*): new insights from microsatellite and mitochondrial data, *Evolution* 52 (1998) 1119–1134.
- [14] Franck P., Cornuet J.-M., Solignac M., Garnery L., Honeybee phylogeography in Europe: new insights from the analysis of Italian honeybees with microsatellite and mitochondrial markers, in: Schwarz M. P., Hogendoorn K. (Eds.), *Social Insects at the Turn of the Century*, Proc. XIII Int. Congr. IUSSI, Flinders Univ. Press, Adelaide, Australia, 1999, p. 170.
- [15] Franck P., Loiseau A., Oldroyd B., Hepburn H.R., Garnery L., Solignac M., Cornuet J.-M., Population genetics of African honeybees: new insights from microsatellites and mitochondrial data, in: 7th IBRA Conf. Tropical Bees, Chiang Mai, 19–25 March, 2000 (in press).
- [16] Garnery L., Cornuet J.-M., Solignac M., Evolutionary history of the honeybee *Apis mellifera* inferred from mitochondrial DNA analysis, *Mol. Ecol.* 1 (1992) 145–154.



- [17] Garnery L., Solignac M., Celebrano G., Cornuet J.-M., A simple test using restricted PCR-amplified mitochondrial DNA to study the genetic structure of *Apis mellifera* L., *Experientia* 49 (1993) 1016–1021.
- [18] Garnery L., Mosshine E.H., Oldroyd B.P., Cornuet J.-M., Mitochondrial DNA variation in Moroccan and Spanish honeybee populations, *Mol. Ecol.* 4 (1995) 465–471.
- [19] Garnery L., Franck P., Baudry E., Vautrin D., Cornuet J.-M., Solignac M., Genetic biodiversity of the west European honeybee (*Apis mellifera mellifera* and *A. m. iberica*). I. Mitochondrial DNA, *Genet. Sel. Evol.* 30 (1998) 31–47.
- [20] Garnery L., Franck P., Baudry E., Vautrin D., Cornuet J.-M., Solignac M., Genetic biodiversity of the west European honeybee (*Apis mellifera* and *A. m. iberica*). II. Microsatellite loci, *Genet. Sel. Evol.* 30 (1998) 49–74.
- [21] Goldstein D.B., Ruiz Linares A., Cavalli-Sforza L.L., Feldman M.W., Genetic absolute dating based on microsatellites and origin of modern humans, *Proc. Natl. Acad. Sci. USA* 92 (1995) 6723–6727.
- [22] Hedges S.B., The number of replication replications needed for accurate estimation of the bootstrap *P*-value in phylogenetic studies, *Mol. Biol. Evol.* 9 (1992) 366–369.
- [23] Kandemir I., Kence A., Allozyme variability in the central Anatolian honeybee (*Apis mellifera* L.) populations, *Apidologie* 26 (1995) 503–510.
- [24] Koulianos S., Crozier R.H., Mitochondrial DNA sequence data provides further evidence that the honeybees of Kangaroo island Australia are of hybrid origin, *Apidologie* 27 (1996) 165–174.
- [25] Lebdigrissa K., Msadda K., Cornuet J.-M., Fresnaye J., Phylogenetic relationships between the Tunisian honeybee *Apis mellifera intermissa* and neighbouring African and west Mediterranean honeybee breeds, *Landbouwtijdschrift* 44 (1991) 1231–1238.
- [26] Nei M., Estimation of average heterozygosity and genetic distance from a small number of individuals, *Genetics* 89 (1978) 145–163.
- [27] Nei M., Tajima F., DNA polymorphism detectable by restriction endonucleases, *Genetics* 97 (1981) 583–590.
- [28] Raymond M., Rousset F., GENEPOP (version 1.2): population genetics software for exact test and ecumenism, *J. Hered.* 86 (1995) 248–250.
- [29] Ruttner F., *Biogeography and Taxonomy of Honeybees*, Springer-Verlag, Berlin, Heidelberg, 1988.
- [30] Ruttner F., Tassencourt L., Louveaux J., Biometrical-statistical analysis of the geographic variability of *Apis mellifera* L., *Apidologie* 9 (1978) 363–381.
- [31] Smith D.R., Mitochondrial DNA and honeybee biogeography, in: Smith D.R. (Ed.), *Diversity in the Genus Apis*, Westview Press and IBH Publ., Oxford, 1991, pp. 131–176.
- [32] Smith D.R., African bees in the Americas: insights from biogeography and genetics, *Trends Ecol. Evol.* 6 (1991) 17–21.
- [33] Smith D.R., Slaymaker A., Palmer M., Kaftanoglu O., Turkish honeybees belong to the east Mediterranean mitochondrial lineage, *Apidologie* 28 (1997) 269–274.



