



HAL
open science

A new WPAN Model for NS-3 simulator

K. El Ghomali, N. Elkamoun, K. M. Hou, Y. Chen, Jean-Pierre Chanet,
Jian-Jin Li

► **To cite this version:**

K. El Ghomali, N. Elkamoun, K. M. Hou, Y. Chen, Jean-Pierre Chanet, et al.. A new WPAN Model for NS-3 simulator. NICST'2103 New Information Communication Science and Technology for Sustainable Development: France-China International Workshop, Sep 2013, Clermont-Ferrand, France. 8 p. hal-00876429

HAL Id: hal-00876429

<https://hal.science/hal-00876429v1>

Submitted on 24 Oct 2013

HAL is a multi-disciplinary open access archive for the deposit and dissemination of scientific research documents, whether they are published or not. The documents may come from teaching and research institutions in France or abroad, or from public or private research centers.

L'archive ouverte pluridisciplinaire **HAL**, est destinée au dépôt et à la diffusion de documents scientifiques de niveau recherche, publiés ou non, émanant des établissements d'enseignement et de recherche français ou étrangers, des laboratoires publics ou privés.

A new WPAN Model for NS-3 simulator

Khalid EL GHOLAMI^{#*1}, Najib ELKAMOUN^{#2}, Kun Mean HOU^{*1}, Yibo CHEN^{*+3}, Jean-Pierre CHANET⁺³, Jianjin LI^{*1}

[#] *Dept. of physics, STIC Laboratory, Chouaib Doukkali University
El Jadida, Morocco*

² elkamoun@ucd.ac.ma

^{*} *Dept. of Computer sciences, LIMOS laboratory CNRS UMR 6158, Blaise Pascal University
Clermont-Ferrand, France*

¹ {khalid.elgholami, kun-mean.hou, jjli}@isima.fr

⁺ *UR TSCF, IRSTEA, Cemagref
Clermont-Ferrand, France*

³ {yibo.chen, jean-pierre.chanet}@cemagref.fr

Abstract— Wireless sensor networks are one of the most challenging topics in research world due to the nature of the wireless communication and the constraints related to the sensor's components. However, this field knows a very fast progress and new technologies are involved. One of the hottest trends of the future WSN is the I/WoT 'Internet/Web of Things'. For the wireless medium access and radio transmission (MAC and PHY), I/WoT has chosen the IEEE 802.15.4 standard. Some researchers have proposed simulation models to analyze this standard in different simulation environment. In this paper we propose a new WPAN model for the NS-3 simulator. This model implements most of the IEEE 802.15.4 standard feature and modes of operations. Furthermore, a 6LoWPAN Model is used to incorporate the IEEE 802.15.4 into the IPv6 architecture by interfacing the IPv6 model of NS-3 with our new IEEE 802.15.4 standard model. Thus, we believe that this WPAN work can be seen as a foundation for future I/WoT simulation on NS-3.

Keywords: IEEE 802.15.4; 6LoWPAN; NS-3; I/WoT; WSN;

I. INTRODUCTION

I/WoT are the future of wireless sensor network applications where each object in our real life will be connected to the internet and can use the web to access and share information. This enable a vast range of applications and a paradigm shift on the way we use internet. However, these new possibilities face many challenging research problems, since these objects are mostly high resource constraint sensors. Low computational power, low memory, scares energy resources and unreliable (lossy) wireless communication are the major problems in this research area. Moreover, nowadays simulation has become a centerpiece that allows us to model, analyze and evaluate new technologies in order to predict the system behavior before real implementation and deployment. It can also be used as part of a real system as it is the case in the simulator-controlled real-world WSN systems.

With this in mind, we proposed a WPAN model for the NS-3 simulator [1] "Network Simulator 3", which is compliant with the IEEE 802.15.4 standard. Our model is based on the NS-2 [2] WPAN model [3]. It supports the Beacon-enabled, non beacon-enabled, and also the beaconless mode that can be used by I/WoT. It's a highly configurable model that allows the user to control the simulation, and get many types of outputs (using pcap API, ASCII, Animation). In this paper, we

also tested this model through a 6LoWPAN adaptation layer implementation that allows us to transmit IPv6 packets over the IEEE 802.15.4 network. Although the current version of this 6LoWPAN supports HC1 and HC_UDP [4] header compression (HC) techniques is a simplified and outdated one but it still has its value as a test case because 6LoWPAN enables P2P connection between wireless nodes using IPv6, and this is the precondition for bringing I/WoT to this platform.

II. OVERVIEW OF THE IEEE 802.15.4 STANDARD

A. IEEE 802.15.4 MAC protocol

This standard proposes a MAC sub-layer that may operate in two alternative modes: non beacon-enabled and beacon-enabled modes. In the non beacon-enabled MAC, the devices manage the channel access using the unslotted CSMA/CA algorithm to avoid collisions. No synchronization is needed and Quality of Service 'QoS' is not guaranteed in this mode, which makes it suitable for application without QoS constraints. In the beacon-enabled mode the network uses a superframe to control the channel access. Figure 1 describes the IEEE 802.15.4 standard superframe format. The latter can be divided into two portions; the active portion and the inactive portion. In one hand, the active portion of the superframe is used to exchange different packets between network nodes. It may optionally be divided into two periods: 1) contention access period (CAP), where network nodes use the slotted CSMA/CA algorithm to contend for channel access. 2) Collision free period (CFP) where the channel is reserved and can be used exclusively by the reserving node using a slot called GTS "Guaranteed Time Slot". The CFP period is optional and it's used by low-latency applications or applications with specific bandwidth requirements. In addition, the sleep portion of the superframe, that is also optional, is used by the nodes to increase their lifetime.

In beacon enabled mode, the entire network is supervised by a node called PAN 'Personal Area Network' Coordinator by advertising periodically a packet called beacon at the beginning of the superframe. The beacons are used to synchronize the attached devices, to identify the PAN, and to describe the structure of the superframe. The beacon may also

provide additional information about the pending addresses and probably the GTS configuration. The superframe timing is based essentially on the Beacon Order (BO) and the Superframe Order (SO). The Final CAP Slot parameter is also used to mark off the CAP period. We use the following equations to calculate different periods:

$$BI = aBaseSuperframeDuration \times 2^{BO} \text{ (symbols)} \quad (I)$$

$$SD = aBaseSuperframeDuration \times 2^{SO} \text{ (symbols)} \quad (II)$$

Where $aBaseSuperframeDuration$ and $aBaseSlotDuration$ are two constants predefined by the standard as 960 and 60 symbols respectively and denote the minimum length of the superframe and that of the slot respectively. Each symbol corresponds to a number of bits depending on the selected physical layer. BI (beacon interval) is the length of the whole superframe. The name comes from the fact that the superframe is bounded by two beacon transmissions. Finally, the Superframe Duration (SD) is the active period length.

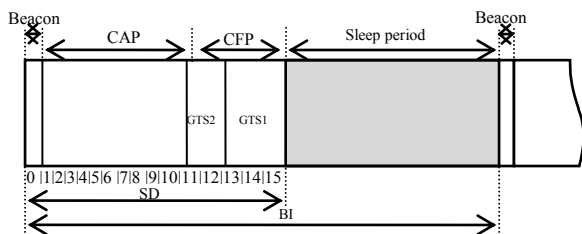

Figure 1. IEEE 802.15.4 superframe structure with options

An additional mode named beaconless may be used as an alternative for simple networks. This mode doesn't support association where all the network nodes are equivalents. Short addresses are not allowed, which turns this mode to a simple unslotted CSMA/CA MAC layer (mesh network). This mode is adopted in the context of I/WoT where the RPL protocol is responsible for building and managing the network topology (using DODAG).

B. IEEE 802.15.4 PHY layer

The PHY (Physical) layer is responsible for transmitting the bit stream to the wireless channel through its radio transceiver. It also receives and decodes the transmitted signals and forward data to the MAC sub-layer. This layer is also responsible for controlling the transceiver status, selecting the channel frequency and performing additional tasks that may be required by the next layers; such as energy detection, clear channel assessment (CCA) and Link Quality Indicator (LQI) measurement for received packets. The IEEE 802.15.4 PHY may operate in three alternative ISM (industrial, scientific and medical) radio bands as detailed in table I.

C. Protocols stack architecture and rules of communication between different layers.

As indicated in figure 2, the interaction between the PHY and the MAC layers is following the OSI (Open System Interconnection) model with a high level of abstraction between layers. The communication is allowed only via

standard interfaces or SAP (Service Access Point), where each layer provides services to its upper layer. Each service may be accessed through up to 4 primitives [5]; request, indication, response and confirm. The PHY layer provides two types of services to the MAC layer through PD-SAP and PLME-SAP interfaces. The first one is used by the MAC layer to send/receive MAC data to/from the PHY layer. The second is used for the rest of the management services. The MAC sub-layer in its turn provides two types of services to its higher layers. The data transfer services (send, receive and purge data) are accessed through the MCPS-SAP interfaces by the SSCS convergence sub-layer. The MLME-SAP is accessed by the upper layer for management purposes. Association, disassociation, scan are some examples among other services provided by the MAC sub-layer to the upper layers.

TABLE I
FREQUENCY BANDS AND BIT/SYMBOL RATES [6]

PHY (MHz)	Frequency band (MHz)	Spreading parameters		Data parameters
		Modulation	Bit Rate (kb/s)	Symbol rate (Ksymbol/s)
868/915	868–868.6	BPSK	20	20
	902–928	BPSK	40	40
868/915 (optional)	868–868.6	ASK	250	12.5
	902–928	ASK	250	50
868/915 (optional)	868–868.6	O-QPSK	100	25
	902–928	O-QPSK	250	62.5
2450	2400–2483.5	O-QPSK	250	62.5

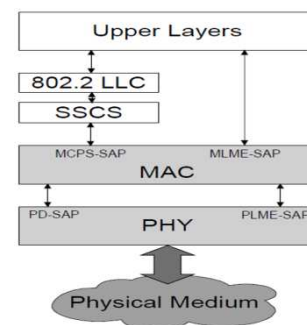

Figure 2. LR-WPAN device architecture [6]

III. OVERVIEW OF THE 6LOWPAN STACK

Nowadays various implementations of 6LoWPAN stacks are available, which has been proved its importance and indispensability for the next generation WSN since IETF 6LoWPAN Working Group was formed. In [7], we presented a survey on the current 6LoWPAN implementations such as uIP/Contiki, SICSslowpan, 6lowpancli, B6LoWPAN, BLIP, NanoStack and Jennic's stack. These emerging research projects or productions reflected the efforts of this domain, and the influence and interest brought by adopting IPv6 in WPAN networks. Thanks to the contribution of 6LoWPAN Working Group, they solved the existed problems of special requirements for IPv6 protocol extended for WPAN steadily

(such as fragmentation and reassembly, header compression, neighbor discovery adaptation, etc.).

The basic concept of 6LoWPAN stack is illustrated in figure 3. 6LoWPAN is an adaptation layer dedicated to various header compression techniques specified in [4] and [8]. The former mainly proposed a mechanism for optimizing the compression for unicast link-local addresses. Specification [4] is an improved version, especially for some issues like: optimizations for multi-cast address, adding more compression on the traffic class and flow label field, using share contexts for non-link-local addresses. Notice that [8] will be replaced by [4], as it supports only one HC technique, but this decision has not been chartered yet.

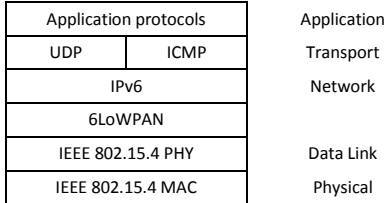

Figure 3. Basic structure of 6LoWPAN stack

For a better compatibility with IPv6, the 6LoWPAN adaptation layer also uses header stacking and defines encapsulation header stack that are added in front of each IPv6 datagram. Considering the limited MTU of IEEE 802.15.4, 6LoWPAN will dramatically reduce the IPv6 header size to a few bytes, which is the main target of this adaptation layer. Furthermore, as we mentioned in the introduction, enabling to carry IPv6 packets over the IEEE 802.15.4 frames doesn't mean that this WPAN is a smart object networks, but it is the prerequisite for I/WoT.

IV. RELATED WORKS

A. Existing IEEE 802.15.4 standard simulation models

Since 2003, when the first standard for LR-WPAN network has been released (i.e. IEEE 802.15.4-2003 standard), several models have been proposed for different simulation platforms to evaluate and study the behavior of this standard and other proposed new IEEE 802.15.4-like Protocols. Reference [3] proposed a WPAN simulation model for the NS-2 simulator. This model supports most of the standard functionalities. Security and GTS management and usage is not supported. Authors in [9] proposed another simulation model for OPNET simulator their module enable only the beacon-enabled MAC mode with GTS management support. The unslotted CSMA/CA MAC protocol was not implemented, and the PAN management is also not supported. Another model is proposed in [10] for the OMNeT++ simulator. This model has many features, and was validated against some test-beds.

In this paper we propose a new WPAN model for the IEEE 802.15.4 standard. It's is based on the NS-2 WPAN model; one of the most used models in WSN research community.

B. Overview of the NS-3 simulator

NS-3 (Network Simulator - 3) is supposed to be the successor of the well-know NS-2 simulator. NS-2 has many

inconvenient, technical issues and limitations, which have motivated the development of NS-3 simulator that can provide better modularity and performance to replace the original simulator. The key concepts behind it are modularity, re-usability and extensibility. However, it's not a new version of NS-2, but completely a new simulator. NS-3 is a discrete-event network simulator for internet written in pure C++. This simulator can be distinguished from its competitors by following a set of high level design goals. For instance, Callback-driven events and connections, flexible core with helper layer, emphasis on emulation and the alignment with real-world interfaces like the sockets and net devices. A performance comparison amongst some simulators was performed in [11], and revealed that NS-3 demonstrated the best overall performance. It is worth to talk about its tracing file function, especially, that it can generate both of the standard text files and simulation output in the PCAP format.

V. WPAN SIMULATION MODEL ON NS-3

Our NS-3 WPAN model follows the same IEEE 802.15.4 device architecture (see figure 2 and 4), where the MAC, PHY, SSCS and the upper layer communicate exclusively via standard interfaces using NS-3 Callbacks. This new design allows a better separation between different layers and makes our model easy to extend. Beside this architecture we adopt the NS-3 network device philosophy. This network device is very important in NS-3 simulator since it allows the upper layer to communicate with any type of data link layer in the same way. No changes are needed in the upper layer to be able to support our model.

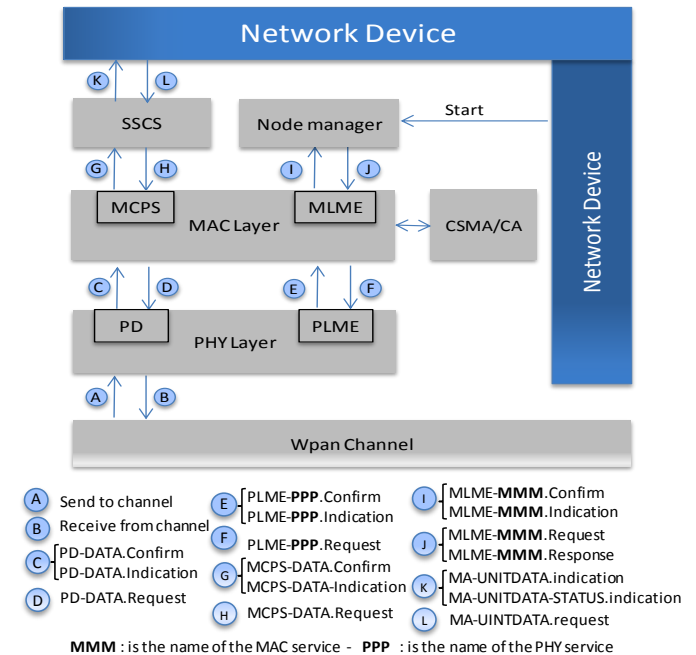

Figure 4. WPAN model architecture

The same logic is used in 6LoWPAN model for a clear structure and easy configuration, which can be easily installed and compliant with our WPAN model as illustrated in figure 5.

Our WpanNetDevice also facilitates the nodes setting, by linking the callbacks and setting the PHY and MAC layer to their default configuration. Moreover, the user has a large set of possible configuration to customize the PHY and the MAC layers. He can change physical layer type, the channel mask, MAC sub-layer mode, MAC configuration and many other simulation parameters.

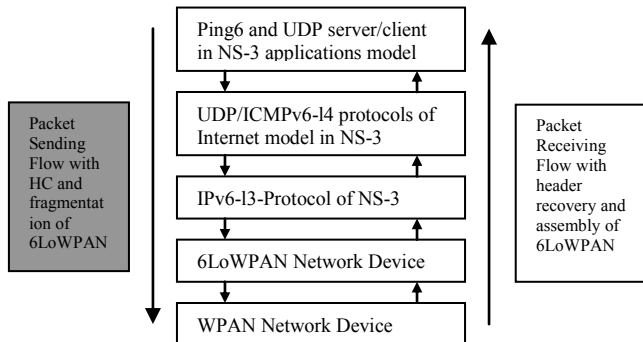

Figure 5. 6LoWPAN Model architecture

A. PHY Layer

In our model all the PHY layers defined by the IEEE 802.15.4-2006 standard are supported. Different data rates, symbol rates, channel ranges and pages are implemented to provide a better comparison amongst different physical layers. The WpanPhy module allows sending and receiving data from/to the wireless channel (WpanChannel in our case), performing Energy Detection (ED), CCA and the channel selection. It also measure (calculates in simulation) the LQI of the received packet and forward this value to the MAC sub-layer. All these services are offered to the MAC layer through the PLME and PD callbacks. The attributes required to configure the PHY layer are managed by the Ppib module which represents the PPIB “PHY PAN Information Base”.

B. MAC layer

This component supports different MAC modes; beacon-enabled, non beacon-enabled and beaconless. In latter mode the user can start the network nodes at the beginning of the simulation since there is no association. The medium access is managed using the unslotted CSMA-CA. All the nodes are similar and use only extended 64 MAC addresses. In non beacon-enabled mode, the nodes can use short addresses after being associated to their coordinator; that can be the 6LoWPAN gateway in the context of I/WoT. The medium access is controlled by the unslotted CSMA-CA algorithm since the beacon transmission is disabled and no synchronization is needed. In beacon-enabled mode, the user can provide some parameter to manage the superframe such as the BO and SO parameters, device capability (FFD or RFD), etc. The MAC attributes are managed by the Mpib module “MAC PAN Information Base”.

For data verification, we implemented an FCS mechanism employing a 16-bit ITU-T cyclic redundancy check (CRC) calculation algorithm as specified by the standard. The CRC checking can be disabled to speed up the simulation.

C. SSSC Layer

SSCS ‘Service-specific convergence sub-layer’ is a simple adaptation layer that provides an interface between an instance of an IEEE 802.2 LLC sub-layer and the IEEE 802.15.4 MAC sub-layer trough the MCPS primitives. In our model, the SSSC adapt message exchanged between WpanMac module and the WpanNetDevice module through the primitives specified in the IEEE 802.15.4 standard.

D. WPAN Device Manager

This component is not defined in the standard specification. However it was introduced in our model since the current existing NS-3 upper layers has no mechanism to manage the node via its MLME-SAP. This module holds all the management operation, and can use the MAC management services through the MLME-SAP callbacks. Moreover, this component may be ignored when using any upper layer that can manage the node (e.g. ZigBee). No change is required in the MAC layer in this case; we only need to connect the MAC MLME-SAP callbacks to the new upper layer model.

E. WPAN Network Device

The WPAN network device (WpanNetDevice) covers both the software driver and the simulated hardware as it’s the case of all link layer models in NS-3. In our model the WPAN network device is a kind of container that holds the IEEE 802.15.4 protocol stack including the NodeManager module. It’s also responsible for connecting different layers interfaces using NS-3 callbacks. All the device settings are centralized in this component and can be exclusively done through it.

The WpanNetDevice also replace the 802.2 LLC sub-layer and can exchanges messages between SSSC and upper layers using standard interfaces as described in figure 4 (K and L primitives). However, the user can disable the LLC/SNAP header since it may not be needed by some upper layers.

F. 6LoWPAN Layer

This 6LoWPAN layer is based on the structure of an open source project [12] for NS-3. The implementation is based on [13] RFC and inspire from the SICSLoWPAN implementation of Contiki. The main reason that we still follow the old standard because it’s simplified and sufficient to be a test case for our intricate WPAN model. There are several necessary improvements for the facets like HC_UDP, timer for storage of 6LoWPAN fragmentations, UDP, ICMPv6 and IPv6 models of NS-3, and also some adjustments for a better observation in WireShark. As an assistant of testing WPAN model, this 6LoWPAN layer supports the interconnection between our WPAN model and upper layers of NS-3. Furthermore, this provides more choices for our future work of building I/WoT protocol stack on this simulator.

G. Wireless channel

The WpanChannel is the component that simulates the real shared wireless media. It’s used to propagate the transmitted signals (Packets) to all connected radio transceivers that are in POS (Personal Operating Space) of the sender and that use the same channel frequency and modulation type.

H. Energy model

Our energy model is based on the NS-3 energy framework proposed in [14]. We extended a new energy device model that we named WpanDeviceEnergyModel. This module can use any of the existing energy source models. The concept is simple as illustrated in figure 6, after each operation done by the radio transceiver (Rx, Tx, Idle, sleep, etc.) the amount of current is consumed from the battery (energy source). If the battery is empty the node is notified and it cannot receive any further signal from the channel (considered as a dead node). In what concern the beacon enabled mode, especially when $BO > SO$, the MAC layer can put the node to sleep/awake mode to save energy.

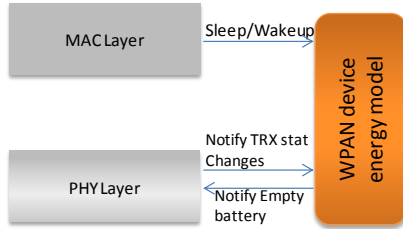

Figure 6. WPAN Energy Device Model

I. Tracing

NS-3 provides different type of tracing and logging capabilities. In our model we can enable all sorts of simulation outcomes offered by NS-3. First, we provide some tracing helpers to produce different ASCII trace files in order to collect as much outputs as we can from simulation. However, to avoid large trace files and overwhelming output data; mainly in heavy simulations, we provide the possibility to specify the type of information needed in outputs. Second, we provided another important feature by using the pcap (Packet Capture) API to trace sent and received packets information. In our implementation, the bit stream in the packet buffer is fully compliant with the IEEE 802.15.4 standard and 6LoWPAN protocol and can be decoded using any packet capture analyzing tools (see figure 7). Third, animation is also an interesting tool that can be used in order to analyze visually the network behavior. It's also very important for teaching purposes to visualize the nodes distribution, the network operation and formation. For this reason we modified the NS-3 NetAnim [15] interfaces to support our new module. An example of one hope topology formed by one Edge Router and 63 nodes is displayed in figure 8 using the NetAnim tool.

VI. PERFORMANCE EVALUATION

The aim of this performance evaluation is to test the basic operations and features proposed by our WPAN model. Table II summaries the common simulation parameters used in all scenarios. Figure 7 shows an example of packets captured using NS-3 pcap tracing feature. It shows a 50 bytes UDP packet sent using IPv6 protocol and 6LoWPAN adaptation layer. The MAC layer operates in beacon-enables mode and the nodes use the MAC short addresses. The MAC FCS calculation is enabled to check the packet integrity. We can clearly see that the bit streams of the packet headers are

compliant with their corresponding standards. The 6LoWPAN layer compressed about 30% of the original IPv6 packet size (Original Frame 98 bytes / compressed Frame 68 bytes).

TABLE II
COMMON SIMULATION PARAMETERS

Parameter	Value
Topology	Star
Application	UDP client/server
Network Layer	IPv6/6LoWPAN
MAC/PHY	IEEE 802.15.4
Packet size (application)	50 bytes
Propagation loss model	FriisPropagationLossModel
Propagation delay	ConstantSpeedPropagationDelayMode



Figure 7. Example of using Wireshark to analyze captured UDP packet sent over the IEEE 802.15.4 standard

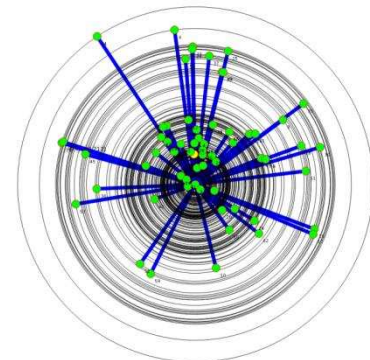

Figure 8. Example of WPAN star network using NetAnim animation tool

A. Test the propagation loss models

Scenario 1: propagation model without interference

The comparison amongst existing propagation models is out of the scope of this paper. However, our WPAN model was successfully simulated and tested with all of them. The aim of this scenario is to verify data transmission through the WPAN physical channel. In this scenario, we set two nodes; a sender which is a fixe node that send continuously 50 bytes UDP packets every 100ms (4kbps), and a destination mobile node moving away from the first node's position in a constant speed (0.1m/s). The MAC sub-layer operates in beaconless mode in order to avoid any interruptions due to the association time, beacon transmissions or sleep time. We use the 2.4GHz PHY with a receiver sensitivity of -85dBm and a transmit power of 1mW (0dBm). Figure 9 points out the evolution of the received signal strength for different distances. The measured RSS continues to decrease while the receiver rolls away from the sender. The receiver continues to receive the packets until nearly 82 meters. After this distance, the RSS decreases to less than -85dBm and the signal is considered as undetectable. This distance represents the transmission range that can vary depending different factors such as transmitting power and the receiving sensitivity.

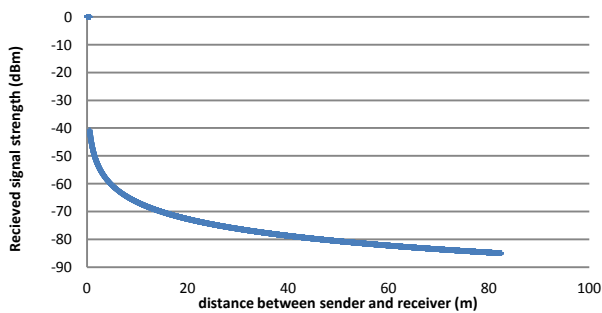

Figure 9. RSSI vs. distance using Friis model without interference (2 nodes)

Figure 10 shows, for the same scenario, the measured LQI after a successful signal reception (RSSI above the Rx Threshold). We can easily notify that after 60 meters the link quality indicator start decreasing from the maximum value (255) until nearly 128 which can be considered as the minimum acceptable LQI. After that distance, the signal is not detected by the destination node's transceiver.

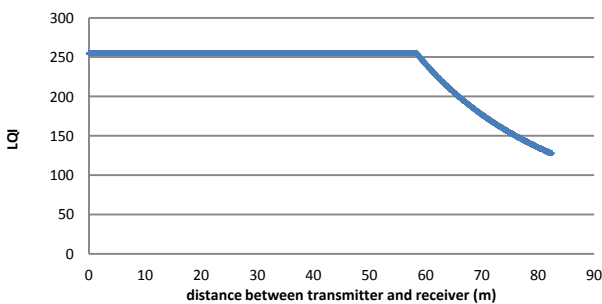

Figure 10. LQI vs. distance using Friis model without interference (2 nodes)

Scenario 2: propagation model with interference

In this scenario we set a network of 19 source nodes with fix positions in addition to a one moving destination node. We kept the same simulation parameters from previous scenario

for all sending nodes. If we compare figure 11 with figure 9; we remark that the RSSI has increased in some positions. This behavior can be explained by the influence of the interference, since the device provides the total measured power during packet reception time, hence, the measured power (Or RSSI) may be higher than the received packets power. These results confirm the fact that the RSSI is not the best parameter to use in order to evaluate the quality of the link.

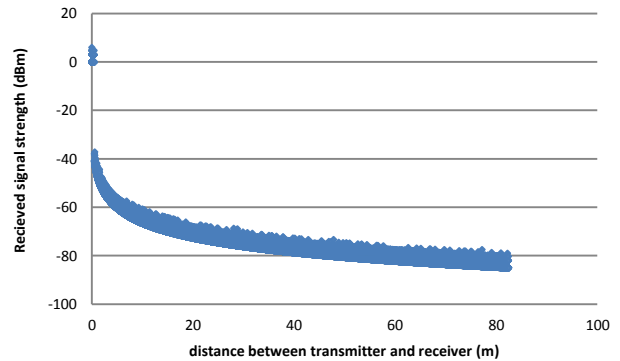

Figure 11. RSSI vs. distance using Friis model propagation loss, with interference (20 nodes)

The LQI can be a better indicator for the link quality; this is brought to light by the results illustrated in figure 12 for the same scenario. When interference occurs, the LQI decreases considerably to indicate a bad LQI. This LQI becomes lower when the number of simultaneous collisions increases (different LQI levels), which reflects the correct link quality. The adopted LQI measurement algorithm in our model (ported from NS-2 WPAN model) uses energy and SNR measurement to provide a better estimation of the link quality.

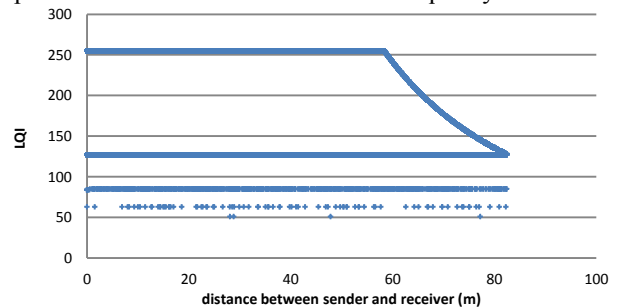

Figure 12. LQI vs. distance using Friis propagation loss model, with interference (20 nodes)

B. Delay (Different MAC)

Scenario 3: Beaconless

In this scenario we aim to measure the one hop delay using all existing PHY layers for different nodes densities (From 2 to 64 nodes in a star topology). All source nodes send 50 bytes UDP packets each 0.1s (4kbps) to a single sink node. Figure 13 reveals that the measured delay is influenced by three factors; first, the nodes density that has a considerable impact on the medium access time. When the number of contenders increases, the collisions probability increases. And according to the CSMA-CA algorithm, the backoff exponent increases to reduce the number of collisions, which will be

translated to high additional delay. The second factor is the bandwidth provided by the used PHY layer. If the bandwidth is not sufficient, the number of collisions increases and the contention for medium access becomes ruder, which leads us to the same conclusion of the previous factor. The last factor is the symbol rate; this parameter has an impact on the internal MAC sub-layer mechanism, since the backoff is calculated in terms of symbols, which means that the backoff time becomes more significant if the symbol rate is slow. This impact is highlighted in the case of the 868MHz O-QPSK PHY layer, where, even with a bit rate of 250 Kbps (same as 2.4GHz, 915 MHz ASK), the delay is higher than all these layers. The reason behind this behavior is that the symbol rate of the PHY 868 MHz O-QPSK is very low (12.5 ksymbol/s), which leads to a longer backoff translated to an extra delay.

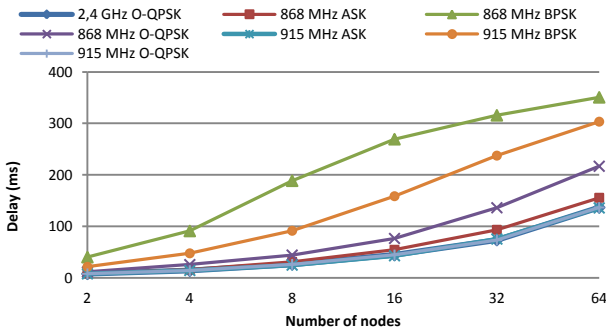

Figure 13. Delay vs. Number of nodes for different PHY Layers

Scenario 4: Beacon enabled

In this scenario we evaluate the influence of the superframe parameters (i.e. BO and SO) on the transmission delay. This performance metric is evaluated for different node numbers. We send UDP packets from different sources to one sink at a rate of 4 Kbps. BO is fixed to 8 and BO varies from 2 up to 8. Figure 14 shows that the delay increase by lowering the duty cycle (or in other words, when the sleep time increases), since when BO>SO, the nodes can switch between sleep and wakeup periods to save energy. During sleep time, the senders store the application data in their buffers queue until the beginning of the next superframe. This storage time is translated to an additional delay. The energy/delay tradeoff is one of the major problems WSN networks, which leads the network designer to choose carefully the data rate and the duty cycle ratio according to the sensors constraints and the application requirements in terms of QoS ‘Quality of Service’.

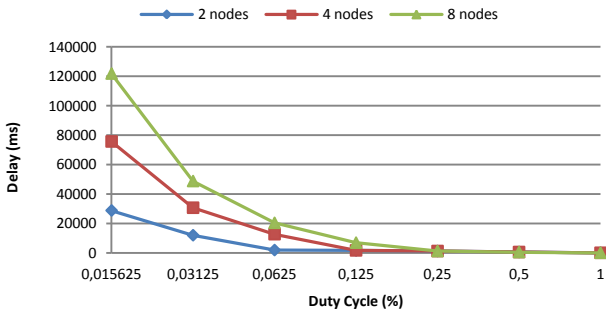

Figure 14. Delay vs. Beacon Order for different nodes densities

C. Throughput (different PHY)

The IEEE 802.15.4 is designed for low data rate networks (e.g. WSN). Hence, it proposes a set of PHY layers with different bandwidths up to 250 Kbps as defined by the standard specification. The aim of this sub-section is to evaluate the throughput for these PHY layers under different network conditions. We start by the measurement of the maximum effective throughput using PHY 2.4 GHz which provides theoretically up to 250 Kbps. As we can see in figure 15, the measured throughput follows the application layer data rate until nearly 56 Kbps. After that limit, even if we increase the data rate, the throughput stays limited to 56 Kbps.

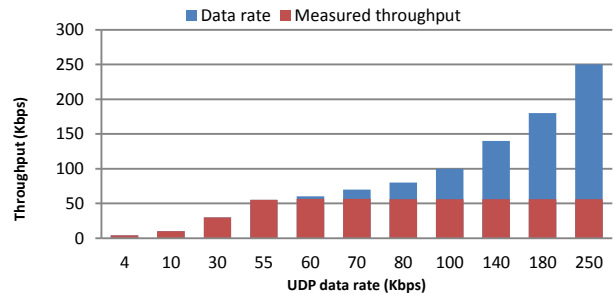

Figure 15. Maximum Throughput for different data rates

These results can be justified by the bandwidth wastage due to packet overhead, the CSMA/CA algorithm (backoffs and CCA) and the IFS (Inter-Frame Spacing) time.

In figure 16, we compare the maximum throughput with the standard bandwidth for all existing PHY variants. We note that we measured the received UDP throughput and the MAC DATA throughput to analyze the influence of the appended headers (overhead) to the UDP packets on the size of the packets and by consequence on the bandwidth efficiency. We get the same behavior as in the previous scenario. As we indicated before, we send UDP packets using IPv6 layer protocol that adds a big header if compared to the maximum payload size allowed by the IEEE 802.15.4 MAC layer “aMaxMACPayloadSize” (MAC constant equal to 118 bytes and represent the maximum number of octets that can fit in the MAC payload). The MAC layer in its turn may append up to 25 bytes to the upper layer packets. In some worst case the packet header size can be equal to or more than the application layer payload length. However, thanks to the 6LoWPAN layer, we can compress most of this header to smaller size to increase the bandwidth efficiency by using some compression algorithms such as HC1 and HC2.

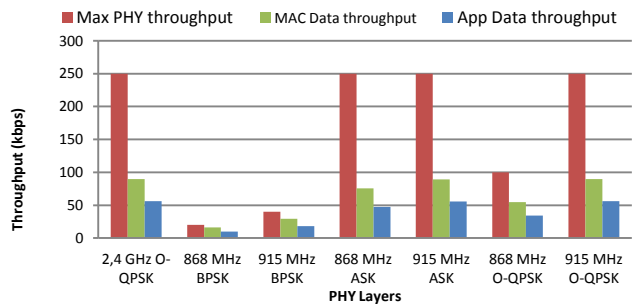

Figure 16. Maximum and effective data throughput for different PHYs

In figure 17, we measured the throughput in different nodes densities. Obviously, the bandwidth utilization for each node decreases when the number of contenders increases because of interference as illustrated in the curves.

What is said for delay is also true for throughput, since the throughput limit is governed by both the PHY layer type (physical modulation) and the MAC layer protocol. The symbol rate has an influence on the throughput since the CSMA-CA backoff calculation uses number of symbols but not number of octets. For instance, the 868MHz ASK and 868 MHz O-QPSK PHY layers have the same data rate but different symbol rates, which causes the throughput to be different. However, 915 MHz O-QPSK and 2.4 GHz O-QPSK have the same bandwidth and symbol rates; hence the throughput is quite the same (the two curves confounded).

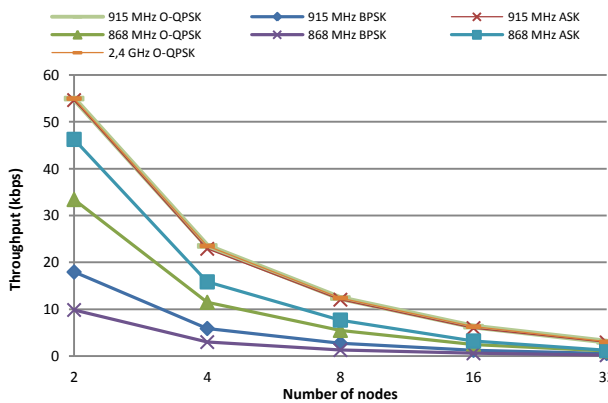

Figure 17. Throughputs using different IEEE 802.15.4 PHY layers for different nodes numbers

VII. CONCLUSION & PERSPECTIVES

In this paper we presented a new WPAN model for the NS-3 simulator. This model implements most of the IEEE 802.15.4 standard features such as different MAC sub-layer modes and all specified physical layers. We also respected in our model, the abstraction concept, where the communication between different layers is allowed only via standard interfaces (SAP). Different tracing possibilities are presented and some helpers are provided to ease simulation setup. The performance evaluation through different scenarios demonstrated that this model provides the expected behavior.

The obtained results are encouraging and open many research perspectives. For our future works we aim to implement the GTS management (only GTS request command management is available now). We are also working on the implementation of other I/WoT components such as RPL (Routing Protocol for Low power and Lossy networks), ND mechanism (Neighbor discovery) and CoAP (Constrained Application Protocol); in order to build up a complete I/WoT protocol stack in NS-3 simulator. Another interesting target for our future works is to validate our model against real test-bed by using the iLive nodes [16][17].

ACKNOWLEDGMENT

This project is supported by the Franco-Moroccan cooperation program "STIC", the CNRST Morocco, the

French government research program "Investissements d'avenir" through the IMobS3 Laboratory of Excellence (ANR-10-LABX-16-01), by the European Union through the program Regional competitiveness and employment 2007-2013 (ERDF-Auvergne region), and by the Auvergne region.

REFERENCES

- [1] "NS-3: Network Simulator 3." [Online]. Available: <http://www.nsnam.org>.
- [2] "The Network Simulator - ns-2." [Online]. Available: <http://www.isi.edu/nsnam/ns>.
- [3] J. Zheng, Myung J. Lee, "A comprehensive performance study of IEEE 802.15.4," *Sens. Netw. Oper. IEEE Press Wiley Intersci.*, vol. 4, pp. 218-237, 2006.
- [4] J. Hui and P. Thubert, "Compression Format for IPv6 Datagrams over IEEE 802.15.4-Based Networks." [Online]. Available: <http://tools.ietf.org/html/rfc6282>.
- [5] "ISO/IEC 9646-7:1995 - Information technology -- Open Systems Interconnection -- Conformance testing methodology and framework -- Part 7: Implementation Conformance Statements."
- [6] IEEE Computer Society, "802.15.4 IEEE Standard for Information technology." 2006.
- [7] C. Yibo, K. Hou, H. Zhou, H.-L. Shi, X. Liu, X. Diao, H. Ding, J.-J. Li, and C. de Vaulx, "6LoWPAN Stacks: A Survey," in *2011 7th International Conference on Wireless Communications, Networking and Mobile Computing (WiCOM)*, 2011, pp. 1-4.
- [8] N. Kushalnagar, G. Montenegro, D. E. Culler, and J. W. Hui, "Transmission of IPv6 Packets over IEEE 802.15.4 Networks." [Online]. Available: <http://tools.ietf.org/html/draft-ietf-6lowpan-format-13>.
- [9] P. Jurcik, A. Koubaa, M. Alves, E. Tovar, and Z. Hanzalek, "A Simulation Model for the IEEE 802.15.4 protocol: Delay/Throughput Evaluation of the GTS Mechanism," in *15th International Symposium on Modeling, Analysis, and Simulation of Computer and Telecommunication Systems, 2007. MASCOTS '07*, 2007, pp. 109-116.
- [10] F. Chen and F. Dressler, "A Simulation Model of IEEE 802.15.4 in OMNeT," in *In 6. GI/ITG KuVS Fachgespräch Drahtlose Sensornetze, Poster Session*, 2007, pp. 35-38.
- [11] E. Weingartner, H. vom Lehn, and K. Wehrle, "A Performance Comparison of Recent Network Simulators," in *IEEE International Conference on Communications, 2009. ICC '09*, 2009, pp. 1-5.
- [12] Pecorella and Tommaso, "ns-3-6LoWPAN." [Online]. Available: <http://code.nsnam.org/tpecorella/ns-3-6LoWPAN>.
- [13] G. Montenegro, N. Kushalnagar, J. Hui, and D. Culler, "RFC 4944-IPv6 over Low Power Wireless Personal Area Networks (6LoWPAN) RFC."
- [14] H. Wu, S. Nabar, and R. Poovendran, "An energy framework for the network simulator 3 (NS-3)," in *Proceedings of the 4th International ICST Conference on Simulation Tools and Techniques*, ICST, Brussels, Belgium, Belgium, 2011, pp. 222-230.
- [15] "NetAnim - Nsnam." [Online]. Available: <http://www.nsnam.org/wiki/index.php/NetAnim>.
- [16] H.-L. Shi, K. M. Hou, H.-Y. Zhou, and X. Liu, "Energy Efficient and Fault Tolerant Multicore Wireless Sensor Network: E²MWSN," in *2011 7th International Conference on Wireless Communications, Networking and Mobile Computing (WiCOM)*, 2011, pp. 1-4.
- [17] "iLive Platform." [Online]. Available: <http://edss.isima.fr/auth/home.php>.