



HAL
open science

Decomposing oriented graphs into 6 locally irregular oriented graphs

Julien Bensmail, Gabriel Renault

► **To cite this version:**

Julien Bensmail, Gabriel Renault. Decomposing oriented graphs into 6 locally irregular oriented graphs. 2014. hal-00869778v2

HAL Id: hal-00869778

<https://hal.science/hal-00869778v2>

Preprint submitted on 19 Jun 2014

HAL is a multi-disciplinary open access archive for the deposit and dissemination of scientific research documents, whether they are published or not. The documents may come from teaching and research institutions in France or abroad, or from public or private research centers.

L'archive ouverte pluridisciplinaire **HAL**, est destinée au dépôt et à la diffusion de documents scientifiques de niveau recherche, publiés ou non, émanant des établissements d'enseignement et de recherche français ou étrangers, des laboratoires publics ou privés.

Decomposing oriented graphs into 6 locally irregular oriented graphs

Julien Bensmail, Gabriel Renault

Univ. Bordeaux, LaBRI, UMR 5800, F-33400 Talence, France
CNRS, LaBRI, UMR 5800, F-33400 Talence, France

June 19, 2014

Abstract

An undirected graph G is locally irregular if every two of its adjacent vertices have distinct degrees. We say that G is decomposable into k locally irregular graphs if there exists a partition $E_1 \cup E_2 \cup \dots \cup E_k$ of the edge set $E(G)$ such that each E_i induces a locally irregular graph. It was recently conjectured by Baudon *et al.* that every undirected graph admits a decomposition into at most 3 locally irregular graphs, except for a well-characterized set of indecomposable graphs. We herein consider an oriented version of this conjecture. Namely, can every oriented graph be decomposed into at most 3 locally irregular oriented graphs, i.e. whose adjacent vertices have distinct outdegrees? We start by supporting this conjecture by verifying it for several classes of oriented graphs. We then prove a weaker version of this conjecture. Namely, we prove that every oriented graph can be decomposed into at most 6 locally irregular oriented graphs. We finally prove that even if our conjecture were true, it would remain NP-complete to decide whether an oriented graph is decomposable into at most 2 locally irregular oriented graphs.

Keywords: oriented graph, locally irregular oriented graph, decomposition into locally irregular graphs, complexity

1 Introduction

A common class of graphs is the class of *regular graphs*, which are graphs whose all vertices have the same degree. One could naturally wonder about an antonym notion of *irregular graphs*. In this scope, maybe the most natural definition for an irregular graph could be a graph whose all vertices have distinct degrees. Unfortunately this definition is not suitable for undirected simple graphs as an easy argument shows that such a graph with at least two

vertices necessarily has two vertices with the same degree. Indeed, assume G has n vertices and is irregular. Since G is simple, the degree sequence of its vertices is $(0, 1, \dots, n - 1)$. But if one vertex of G has degree $n - 1$, then all of its vertices have degree at least 1. This contradicts the fact that some vertex of G has degree 0.

Several studies then aimed at finding ways for introducing irregularity in undirected simple graphs. One first solution, introduced by Chartrand *et al.* [3], is to turn an undirected simple graph G into an irregular *multigraph*, i.e. a graph with multiple edges, by multiplying the edges of G (i.e. replacing them with several multiple edges). This led to the introduction of the notion of *irregularity strength*, where the irregularity strength $s(G)$ of G can be defined as the least integer $s(G) \geq 2$ for which G can be turned into an irregular multigraph by multiplying each of its edges at most $s(G)$ times.

Since the notion of irregularity above does not fit with undirected simple graphs, we have to consider a weaker notion of irregularity. We may e.g. want a graph to be irregular locally rather than totally. This definition was notably introduced by Alavi *et al.* [1], who defined a *highly irregular* graph as a graph whose every two adjacent vertices have distinct degrees. To accord our terminology to the one introduced in [2], which inspired our investigations, a highly irregular graph is said *locally irregular* throughout this paper. An undirected simple graph G may of course not be locally irregular, e.g. if G is regular, so once again we could try to turn G into a locally irregular multigraph (this consideration gave birth to the so-called *1-2-3 Conjecture*, see [7]).

Another direction for introducing irregularity in G is rather to try to “decompose” G into several locally irregular graphs. More formally, we say that G is *decomposable into k locally irregular graphs* if there exists a partition $E_1 \cup E_2 \cup \dots \cup E_k$ of $E(G)$ such that $G[E_i]$ is locally irregular for every $i \in \{1, 2, \dots, k\}$. Note that finding a decomposition of G into k locally irregular graphs is similar to finding an improper k -edge-colouring of G such that each colour class induces a locally irregular graph. Such an edge-colouring is said *locally irregular* for convenience. As usual, we are interested in the least number of colours used by a locally irregular edge-colouring of G . This parameter is called the *irregular chromatic index* of G , denoted $\chi'_{irr}(G)$, and is defined as ∞ when G does not admit any locally irregular edge-colouring (note e.g. that the irregular chromatic index of every path or cycle with odd length is not finite).

It is conjectured that every undirected “colourable” graph G , i.e. whose irregular chromatic index is finite, can be decomposed into at most 3 locally irregular graphs [2]. This conjecture was verified for several classes of graphs, including trees, complete graphs, and regular graphs with large degree which are, in some sense, the least locally irregular graphs. However, no constant

upper bound on the number of necessary colours has been found so far, so no weaker version of the conjecture mentioned above has been proved.

We here consider this problem in the context of oriented graphs, where the notions of regularity and (local) irregularity are with respect to the *out-degree* parameter¹. Namely, an oriented graph \vec{G} is regular (resp. irregular) if all its vertices have the same (resp. distinct) outdegrees. In case every two adjacent vertices of \vec{G} have distinct outdegrees, we say that \vec{G} is locally irregular. The notions of locally irregular arc-colouring and irregular chromatic index of \vec{G} then follows naturally as in the undirected case. Note that, as for the undirected case, our investigations are somehow justified since \vec{G} is irregular if and only if \vec{G} is a transitive tournament. Hence irregular oriented graphs have a very restricted structure. Note further that a single arc is a locally irregular oriented graph, while a single edge is clearly not a locally irregular graph. Therefore, the irregular chromatic index of every oriented graph is defined since a locally irregular $|A(\vec{G})|$ -arc-colouring of \vec{G} , where $A(\vec{G})$ is the set of arcs of \vec{G} , is obtained by assigning one distinct colour to each arc of \vec{G} .

Investigations on small oriented graphs suggest that, as for the undirected case, the irregular chromatic index of every oriented graph should be upper bounded by 3.

Conjecture 1. *For every oriented graph \vec{G} , we have $\chi'_{irr}(\vec{G}) \leq 3$.*

This paper is mainly devoted to Conjecture 1. We support this conjecture by showing it to hold for several classes of graphs in Section 2. We then prove a weaker version of Conjecture 1 in Section 3. Namely, we prove that $\chi'_{irr}(\vec{G}) \leq 6$ for every oriented graph \vec{G} . We finally turn our concerns on algorithmic aspects in Section 4. In particular, we prove that deciding whether the irregular chromatic index of an oriented graph is at most 2 is an NP-complete problem. In case Conjecture 1 turned out to be true, this would imply that oriented graphs with irregular chromatic index 2 are not easy to recognize, unless P=NP. Some concluding remarks and open questions are gathered in concluding Section 5.

Some terminology and notation

Let \vec{G} be an oriented graph, and ϕ be a k -arc-colouring of \vec{G} for some $k \geq 1$. We denote by $V(\vec{G})$ and $A(\vec{G})$ the vertex and arc sets of \vec{G} , respectively. Throughout this paper, the *i-subgraph* of \vec{G} (induced by ϕ) refers to the subgraph of \vec{G} induced by colour i of ϕ for any $i \in \{1, 2, \dots, k\}$. Given a vertex v of \vec{G} , the *i-outdegree* of v refers to the outdegree of v in

¹Note that our investigations could have been done with respect to the *indegrees* instead.

the i -subgraph. We denote this parameter $d_{\phi,i}^+(v)$. We refer the reader to [4] for every other usual notation or terminology.

2 Oriented graphs supporting Conjecture 1

Throughout this section, we exhibit families of oriented graphs for which Conjecture 1 holds. Namely, we prove Conjecture 1 to hold for oriented graphs whose underlying graph has chromatic number at most 3, acyclic oriented graphs, and Cartesian products of oriented graphs with irregular chromatic index at most 3.

2.1 Oriented graphs whose underlying graph is k -colourable

The *underlying graph* of an oriented graph \vec{G} , denoted $und(\vec{G})$, is the undirected graph obtained from \vec{G} by “replacing” every arc by an edge. A *proper k -vertex-colouring* of an undirected graph G is a partition of $V(G)$ into k parts $V_1 \cup V_2 \cup \dots \cup V_k$ such that V_i is an independent set for every $i \in \{1, 2, \dots, k\}$. The *chromatic number* $\chi(G)$ of G is the least number of colours in a proper vertex-colouring of G . In the next result, we show that every oriented graph whose underlying graph is k -colourable, i.e. admits a proper k -vertex-colouring, admits a locally irregular k -arc-colouring.

Theorem 2. *For every oriented graph \vec{G} , we have $\chi'_{irr}(\vec{G}) \leq \chi(und(\vec{G}))$.*

Proof. Without loss of generality, we may assume that \vec{G} is connected. Let $\chi(und(\vec{G})) = k$, and $V_1 \cup V_2 \cup \dots \cup V_k$ be a proper k -vertex-colouring of $und(\vec{G})$. Consider the k -arc-colouring ϕ of \vec{G} obtained by colouring i every arc whose tail lies in V_i for every $i \in \{1, 2, \dots, k\}$. Now consider every two adjacent vertices u and v . By definition of a proper vertex-colouring, we have $u \in V_i$ and $v \in V_j$ for some $i, j \in \{1, 2, \dots, k\}$ with $i \neq j$. Besides, according to how ϕ was obtained, we have $d_{\phi,i}^+(u) \geq 1$ and $d_{\phi,j}^+(u) = 0$, and $d_{\phi,i}^+(v) = 0$ and $d_{\phi,j}^+(v) \geq 1$, while the arc between u and v is coloured either i or j . It should be thus clear that ϕ is locally irregular. \square

As a special case of Theorem 2, we get that every oriented graph whose underlying graph is a tree, a bipartite graph, or more generally a 3-colourable graph agrees with Conjecture 1.

Corollary 3. *For every oriented graph \vec{G} whose underlying graph is 3-colourable, we have $\chi'_{irr}(\vec{G}) \leq 3$.*

2.2 Acyclic oriented graphs

An oriented graph is *acyclic* if it does not admit a circuit as a subgraph. We herein show that every acyclic oriented graph admits a locally irregular 3-arc-colouring.

Theorem 4. *For every acyclic oriented graph \vec{G} , we have $\chi'_{irr}(\vec{G}) \leq 3$.*

Proof. We actually prove a stronger statement, namely that every acyclic oriented graph \vec{G} admits a locally irregular 3-arc-colouring in which only two colours are used at each vertex, i.e. the arcs outgoing from every vertex are coloured with at most two colours. The proof is by induction on the order n of \vec{G} , i.e. its number of vertices. The claim can be easily verified for small values of n , e.g. for $n \leq 3$. Let us thus assume the thesis holds for every oriented graph with order at most $n - 1$. Since \vec{G} is acyclic, there has to be a vertex of \vec{G} with indegree 0. Let v be such a vertex, and denote its neighbours by u_1, u_2, \dots, u_d , i.e. $\overrightarrow{vu_i}$ is an arc for every $i \in \{1, 2, \dots, d\}$, where $d = d^+(v)$.

Let $\vec{H} = \vec{G} - v$. Since removing vertices from an acyclic graph does not create new circuits, the oriented graph \vec{H} is still acyclic. Besides, it admits a locally irregular 3-arc-colouring $\phi_{\vec{H}}$ with the restrictions above according to the induction hypothesis. Now put back v and its adjacent arcs, and try to extend $\phi_{\vec{H}}$, i.e. colour the arcs outgoing from v , to a locally irregular 3-arc-colouring $\phi_{\vec{G}}$ of \vec{G} satisfying the conditions above. We show below that such an extension from $\phi_{\vec{H}}$ to $\phi_{\vec{G}}$ necessarily exists.

For this purpose, we first show that such an extension necessarily exists whenever $d \leq 3$ before generalizing our arguments. If $d = 1$, then, by our assumptions on $\phi_{\vec{H}}$, at most two colours, say 1 and 2, are used at u_1 . Then by colouring 3 the arc $\overrightarrow{vu_1}$, no conflict may arise and $\phi_{\vec{G}}$ remains locally irregular. Besides, only one colour is used at v .

Now, if $d = 2$, then start by colouring 1 all arcs outgoing from v . If $\phi_{\vec{G}}$ is not locally irregular, then one vertex u_{i_1} has 1-outdegree 2 by $\phi_{\vec{H}}$. Now colour 2 all arcs outgoing from v . Again, if $\phi_{\vec{G}}$ is not locally irregular, then it means that one vertex u_{i_2} has 2-outdegree 2 by $\phi_{\vec{H}}$. Now colour 3 all arcs outgoing from v . If $\phi_{\vec{G}}$ is not locally irregular again, then some vertex u_{i_3} has 3-outdegree 2. Since $d = 2$ and there are at most two colours used at each of the u_i 's, it means that we have revealed all the colours used at one of the u_i 's. Assume $i_1 = i_2 = 1$ without loss of generality. Then u_1 has 1- and 2-outdegree 2, while u_2 has 3-outdegree 2. Note then that by setting $\phi_{\vec{G}}(\overrightarrow{vu_1}) = 1$ and $\phi_{\vec{G}}(\overrightarrow{vu_2}) = 3$, the arc-colouring $\phi_{\vec{G}}$ is locally irregular. Since $d = 2$, note further that at most two colours are used at v , as required.

Finally consider $d = 3$. As previously, start by colouring all arcs outgoing from v with a same colour. Again, if $\phi_{\vec{G}}$ is not locally irregular for every of

these three extensions of $\phi_{\vec{H}}$, then we get that a vertex u_{i_1} has 1-outdegree 3, a vertex u_{i_2} has 2-outdegree 3, and one vertex u_{i_3} has 3-outdegree 3. Now fix $\phi_{\vec{G}}(\overrightarrow{vu_{i_1}}) = 1$ (there is no conflict in the 1-subgraph since u_{i_1} has 1-outdegree 3) and colour all of the remaining arcs outgoing from v with a same colour different from 1. Again, if $\phi_{\vec{G}}$ is never locally irregular, then we get that some vertex u_{i_4} has 2-outdegree 2, and some vertex u_{i_5} has 3-outdegree 2. Similarly, if $\phi_{\vec{G}}$ is not locally irregular when assigning $\overrightarrow{vu_{i_2}}$ colour 2 (again, there is not conflict in the 2-subgraph since u_{i_2} has 2-outdegree 3) and all of the other arcs outgoing from v colour 1, then we get that some vertex u_{i_6} has 1-outdegree 2. At this point, all of the colours of the arcs outgoing from the u_i 's are revealed. Since it was revealed that colour 1 is used at u_{i_6} , either colour 2 or 3 is not used at v_{i_6} . Assume this colour is 2 without loss of generality. Now just assign colour 2 to $\overrightarrow{vu_{i_6}}$, and colour 1 to all of the other arcs outgoing from v . Then v and u_{i_6} are adjacent in the 2-subgraph but have distinct 2-outdegrees, namely 1 and 0, respectively, while v and its other two neighbours are adjacent in the 1-subgraph and have distinct 1-outdegrees since v has 1-outdegree 2 and only u_{i_6} was revealed to have 1-outdegree 2. It then follows that $\phi_{\vec{G}}$ is locally irregular. Note further that at most two colours are used to colour the arcs outgoing from v at every moment of the procedure.

We now generalize our arguments for every $d \geq 4$. The colouring scheme we use below is quite similar to the one used so far. If, at some step, the resulting arc-colouring $\phi_{\vec{G}}$ is locally irregular, then we are done. Suppose this never occurs. We start by colouring with only one colour all arcs outgoing from v (Step 1). Since $\phi_{\vec{G}}$ is never locally irregular, it means that some vertex u_{i_1} has 1-outdegree d , some vertex u_{i_2} has 2-outdegree d , and some vertex u_{i_3} has 3-outdegree d . Next, we try to extend $\phi_{\vec{H}}$ to $\phi_{\vec{G}}$ by colouring with some colour α one arc outgoing from v whose head was shown to have α -outdegree strictly more than 1 in earlier steps of the process (i.e. u_{i_1} , u_{i_2} or u_{i_3}), and then colouring all of the other arcs outgoing from v with a colour different from α (Step 2.a). Again, if $\phi_{\vec{G}}$ is not locally irregular for every of these attempts, then we reveal that some vertex u_{i_4} has 1-outdegree $d - 1$, some vertex u_{i_5} has 2-outdegree $d - 1$, and some vertex u_{i_6} has 3-outdegree $d - 1$. Once the vertices u_{i_4} , u_{i_5} and u_{i_6} are revealed, we can reveal additional 1-, 2- and 3-outdegrees as follows. Since u_{i_4} has 1-outdegree $d - 1$, it means that a colour different from 1, say 2, is not used at u_{i_4} . Then colour 2 the arc $\overrightarrow{vu_{i_4}}$, and 1 all of the other arcs outgoing from v . Then we reveal that a vertex u_{i_7} different from u_{i_1} and u_{i_4} has 1-outdegree $d - 1$. Repeating the same strategy with u_{i_5} and u_{i_6} (Step 2.b), we reveal also that two vertices u_{i_8} (different from u_{i_2} and u_{i_5}) and u_{i_9} (different from u_{i_3} and u_{i_6}) have 2- and 3-outdegree $d - 1$, respectively.

Repeat the same strategy as many times as necessary until $\phi_{\vec{G}}$ is locally irregular, or all of the 1-, 2- and 3-outdegrees of the u_i 's are revealed. More

precisely, for every $j = 3, 4, \dots, \lceil \frac{d}{2} \rceil$ taken consecutively, colour with some colour α exactly $j - 1$ of the arcs outgoing from v whose heads were shown to have α -outdegree strictly more than $j - 1$ in earlier steps, and colour the remaining $d - j + 1$ arcs with some different colour $\beta \neq \alpha$ (Step j.a). At Step j.a, we reveal that some vertex $u_{i_{3+6(j-2)+1}}$ has 1-outdegree $d - j + 1$, some vertex $u_{i_{3+6(j-2)+2}}$ has 2-outdegree $d - j + 1$, and some vertex $u_{i_{3+6(j-2)+3}}$ has 3-outdegree $d - j + 1$. Repeating Step j.a but with “forcing” $u_{i_{3+6(j-2)+1}}$ to be one of the $j - 1$ arcs coloured with some colour not appearing at it, and then similarly for $u_{i_{3+6(j-2)+2}}$ and $u_{i_{3+6(j-2)+3}}$ (Step j.b), we reveal that three other vertices, $u_{i_{3+6(j-2)+4}}$, $u_{i_{3+6(j-2)+5}}$ and $u_{i_{3+6(j-1)}}$, have 1-, 2- and 3-outdegree $d - j + 1$, respectively. We refer to Steps j.a and j.b as Step j.

Hence, at each Step j, we reveal that two of the u_i 's have 1-outdegree $d - j + 1$, two of the u_i 's have 2-outdegree $d - j + 1$ and two of the u_i 's have 3-outdegree $d - j + 1$ (except for Step 1 where only one outdegree of each colour is revealed). Since $d \geq 4$ and there are only two colours used at each vertex u_i according to the assumption on $\phi_{\vec{H}}$, and hence at most $2d$ outdegrees to be revealed, it should be clear that all of the 1-, 2- and 3-outdegrees of the u_i 's are revealed once j reaches $\lceil \frac{d}{2} \rceil$. Besides, every 1-, 2- or 3-outdegree is revealed to be strictly more than $\lceil \frac{d}{2} \rceil$ (except when $d = 5$, see below). One can then obtain the locally irregular 3-arc-colouring $\phi_{\vec{G}}$ by assigning colour 1 to $\lceil \frac{d}{2} \rceil$ arcs outgoing from v whose head were shown to have 1-outdegree strictly more than $\lceil \frac{d}{2} \rceil$, and colour 2 to the remaining arcs (there are $\lfloor \frac{d}{2} \rfloor$ of them). Under this colouring, the vertex v has 1- and 2-outdegree $\lceil \frac{d}{2} \rceil$ and $\lfloor \frac{d}{2} \rfloor$, respectively, while its neighbours have 1- and 2-outdegree 0 or strictly greater than these in the 1- and 2-subgraphs, respectively (when $d = 5$, one of the u_i 's, say u_1 , is revealed to have 1-outdegree 3 - in this special case, force \vec{vu}_1 to be coloured 2. For every other value of d , the revealed outdegrees are strictly greater than $\lceil \frac{d}{2} \rceil$). Besides, only two colours are used at v . This ends up the proof. \square

It is worth noting that the stronger statement proved in the proof of Theorem 4 is crucial for our colouring scheme. Indeed, assume e.g. that $d = 1$, that three colours are allowed at each vertex, and that u_1 has 1-, 2- and 3-outdegree exactly 1 by $\phi_{\vec{H}}$. In such a situation, we clearly cannot extend $\phi_{\vec{H}}$ to $\phi_{\vec{G}}$.

2.3 Cartesian products of oriented graphs with irregular chromatic index at most 3

We herein investigate a last family of oriented graphs, namely Cartesian products of oriented graphs with irregular chromatic index at most 3 (the reader is referred to [6] for details on this construction). The main interest for focusing on this operation is that it provides numerous more examples of

oriented graphs verifying Conjecture 1, assuming that we are provided with oriented graphs agreeing with Conjecture 1 themselves.

Theorem 5. *Let \vec{G} and \vec{H} be two oriented graphs such that $\chi'_{irr}(\vec{G}) \leq k$ and $\chi'_{irr}(\vec{H}) \leq \ell$. Then we have $\chi'_{irr}(\vec{G} \square \vec{H}) \leq \max\{k, \ell\}$.*

Proof. Let $\phi_{\vec{G}}$ and $\phi_{\vec{H}}$ be locally irregular k - and ℓ -arc-colourings of \vec{G} and \vec{H} , respectively. Now let $\phi_{\vec{G} \square \vec{H}}$ be the $\max\{k, \ell\}$ -arc-colouring of $\vec{G} \square \vec{H}$ obtained from $\phi_{\vec{G}}$ and $\phi_{\vec{H}}$ as follows:

$$\phi_{\vec{G} \square \vec{H}}(\overrightarrow{(u_1, v_1)(u_2, v_2)}) = \begin{cases} \phi_{\vec{H}}(\overrightarrow{v_1 v_2}) & \text{if } u_1 = u_2, \\ \phi_{\vec{G}}(\overrightarrow{u_1 u_2}) & \text{otherwise.} \end{cases}$$

Note that we have $d_{\phi_{\vec{G} \square \vec{H}}, i}^+(\overrightarrow{(u_1, v_1)}) = d_{\phi_{\vec{G}}, i}^+(u_1) + d_{\phi_{\vec{H}}, i}^+(v_1)$ for every colour $i \in \{1, 2, \dots, \max\{k, \ell\}\}$. Assume $\overrightarrow{(u_1, v_1)(u_2, v_2)}$ is an arc of $\vec{G} \square \vec{H}$ with $\phi_{\vec{G} \square \vec{H}}(\overrightarrow{(u_1, v_1)(u_2, v_2)}) = i$. By definition, we have either $u_1 = u_2$ or $v_1 = v_2$. Suppose $u_1 = u_2$ without loss of generality. Then we have $d_{\phi_{\vec{G}}, i}^+(u_1) = d_{\phi_{\vec{G}}, i}^+(u_2)$, and, because $\phi_{\vec{H}}$ is locally irregular, also $d_{\phi_{\vec{H}}, i}^+(v_1) \neq d_{\phi_{\vec{H}}, i}^+(v_2)$. It then follows that $d_{\phi_{\vec{G} \square \vec{H}}, i}^+(\overrightarrow{(u_1, v_1)}) \neq d_{\phi_{\vec{G} \square \vec{H}}, i}^+(\overrightarrow{(u_2, v_2)})$. Repeating the same argument for every arc of $\vec{G} \square \vec{H}$, we get that $\phi_{\vec{G} \square \vec{H}}$ is locally irregular. \square

Regarding Conjecture 1, we get the following.

Corollary 6. *For every two oriented graphs \vec{G} and \vec{H} such that $\chi'_{irr}(\vec{G}), \chi'_{irr}(\vec{H}) \leq 3$, we have $\chi'_{irr}(\vec{G} \square \vec{H}) \leq 3$.*

3 Decomposing oriented graphs into at most 6 locally irregular oriented graphs

In this section we show, in Theorem 9 below, that every oriented graph has irregular chromatic index at most 6. For this purpose, we first introduce the following observation stating that if an oriented graph \vec{G} can be “decomposed” into arc-disjoint subgraphs $\vec{G}_1, \vec{G}_2, \dots, \vec{G}_k$, then a locally irregular arc-colouring of \vec{G} can be obtained by considering independent locally irregular arc-colourings of $\vec{G}_1, \vec{G}_2, \dots, \vec{G}_k$.

Observation 7. *Let \vec{G} be an oriented graph whose arc set $A(\vec{G})$ can be partitioned into k parts $A_1 \cup A_2 \cup \dots \cup A_k$ such that $\chi'_{irr}(\vec{G}[A_1]) \leq x_1, \chi'_{irr}(\vec{G}[A_2]) \leq x_2, \dots, \chi'_{irr}(\vec{G}[A_k]) \leq x_k$ for some values of x_1, x_2, \dots, x_k . Then $\chi'_{irr}(\vec{G}) \leq \sum_{i=1}^k x_i$.*

Proof. Let $\phi_1, \phi_2, \dots, \phi_k$ be locally irregular x_1 -, x_2 -, ..., x_k -arc-colourings of $\vec{G}[A_1], \vec{G}[A_2], \dots, \vec{G}[A_k]$, respectively, and denote by ϕ the $(\sum_{i=1}^k x_i)$ -arc-colouring of \vec{G} defined as

$$\phi(\vec{a}) = (\phi_i(\vec{a}), i) \text{ for every } \vec{a} \in A(\vec{G}) \text{ such that } \vec{a} \in A_i.$$

By the partition of $A(\vec{G})$, every arc of \vec{G} receives a colour by ϕ , and ϕ uses $\sum_{i=1}^k x_i$ colours. Besides, the subgraph of \vec{G} induced by colour (j, i) is nothing but the subgraph of $\vec{G}[A_i]$ induced by colour j of ϕ_i , which is locally irregular by the definition of ϕ_i . All subgraphs of \vec{G} induced by ϕ are then locally irregular as required. \square

Observation 7 provides an easy upper bound on the irregular chromatic index of every oriented graph which may be partitioned into arc-disjoint subgraphs with upper-bounded irregular chromatic index. In particular, by showing below that every oriented graph can be arc-partitioned into two acyclic oriented graphs (which have irregular chromatic index at most 3, see Theorem 4), we directly get that every oriented graph has irregular chromatic index at most 6.

Lemma 8. *The arc set of every oriented graph \vec{G} can be partitioned into two parts $A_1 \cup A_2$ such that $\vec{G}[A_1]$ and $\vec{G}[A_2]$ are acyclic.*

Proof. Let v_1, v_2, \dots, v_n denote the vertices of \vec{G} following an arbitrary order. Now consider every arc $\vec{v_i v_j}$ of \vec{G} , and

$$\begin{cases} \text{add } \vec{v_i v_j} \text{ to } A_1 \text{ if } i < j, \\ \text{add } \vec{v_i v_j} \text{ to } A_2 \text{ otherwise.} \end{cases}$$

Then observe that if $\vec{v_{i_1} v_{i_2} \dots v_{i_k} v_{i_1}}$, with $i_1 < i_2 < \dots < i_k$, were a circuit of $\vec{G}[A_1]$, then we would have both $i_1 < i_k$ and $i_k < i_1$, a contradiction. A similar contradiction can be deduced from any circuit of $\vec{G}[A_2]$. \square

Theorem 9. *For every oriented graph \vec{G} , we have $\chi'_{irr}(\vec{G}) \leq 6$.*

Proof. According to Lemma 8, there exists a partition $A_1 \cup A_2$ of $A(\vec{G})$ such that $\vec{G}[A_1]$ and $\vec{G}[A_2]$ are acyclic. Since every acyclic oriented graph has irregular chromatic index at most 3 according to Theorem 4, the thesis follows directly from Observation 7. \square

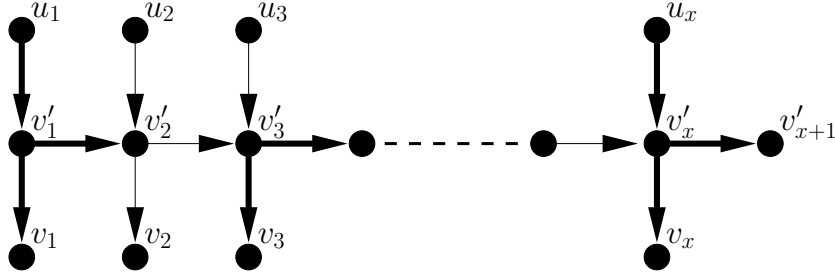

Figure 1: The 2-fiber gadget \vec{F}_2 , and a locally irregular 2-arc-colouring of \vec{F}_2 (thick (resp. thin) arcs are arcs coloured 1 (resp. 2)).

4 Algorithmic complexity

In this section, we deal with the algorithmic complexity of the following decision problem.

LOCALLY IRREGULAR k -ARC-COLOURING

Instance: An oriented graph \vec{G} .

Question: Do we have $\chi'_{irr}(\vec{G}) \leq k$?

Since checking whether \vec{G} is locally irregular can be done in quadratic time, the problem LOCALLY IRREGULAR 1-ARC-COLOURING is in P. In case Conjecture 1 turned out to be true, note that every problem LOCALLY IRREGULAR k -ARC-COLOURING with $k \geq 3$ would be in P. At the moment, by Theorem 9 we only get that LOCALLY IRREGULAR k -ARC-COLOURING is in P for every $k \geq 6$. On contrary, if LOCALLY IRREGULAR k -ARC-COLOURING were shown to be NP-complete for some $k \in \{3, 4, 5\}$, then one would disprove Conjecture 1.

In the light of the previous explanations, only LOCALLY IRREGULAR 2-ARC-COLOURING is of interest at the moment. We prove this problem to be NP-complete in Theorem 12 below. This result implies that, even if Conjecture 1 turned out to be true, no good characterization of oriented graphs with irregular chromatic index at most 2 can exist, unless P = NP.

To prove Theorem 12, we first need to introduce some *forcing* gadgets, i.e. some oriented graphs which will be used in our reduction to “force” the propagation of a locally irregular 2-arc-colouring within an oriented graph.

The *2-fiber* gadget, denoted \vec{F}_2 , is depicted in Figure 1. We refer to the arcs $\vec{v'_1v_1}$, $\vec{v'_2v_2}$, ..., $\vec{v'_xv_x}$ as the *outputs* of \vec{F}_2 . Every output $\vec{v'_iv_i}$ with i odd is referred to as an *odd* output, or as an even output otherwise. Note that \vec{F}_2 is actually made of a same small pattern repeated consecutively from left to right. The dashed section of \vec{F}_2 means that this pattern can be repeated

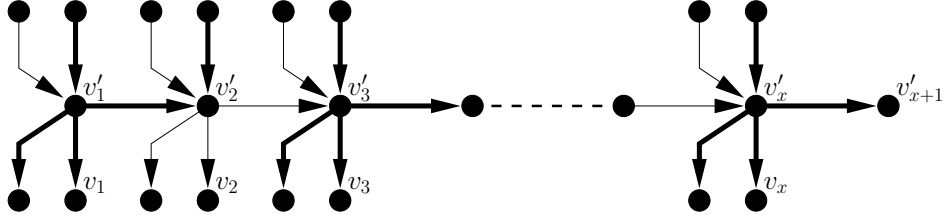

Figure 2: The 3-fiber gadget \vec{F}_3 , where the top-most arcs are outputs of \vec{F}_2 , and a locally irregular 2-arc-colouring of \vec{F}_3 (thick (resp. thin) arcs are arcs coloured 1 (resp. 2)).

an arbitrary number of times, i.e. x can be arbitrarily large, so that \vec{F}_2 has arbitrarily many outputs, which are either even or odd, alternatively. This gadget has the following colouring property.

Lemma 10. *In every locally irregular 2-arc-colouring ϕ of \vec{F}_2 , all of the even outputs of \vec{F}_2 have the same colour, while all of the odd outputs have the second colour. Besides, for every output $\vec{v}'_i v_i$ of \vec{F}_2 , the vertex v'_i has outdegree 2 in the $\phi(\vec{v}'_i v_i)$ -subgraph.*

Proof. Note that for every $i \in \{1, 2, \dots, x\}$, the vertex u_i has α -outdegree 1 by ϕ for some $\alpha \in \{1, 2\}$ and is adjacent to v'_i in the α -subgraph. For this reason, the two arcs $\vec{v}'_i v_i$ and $\vec{v}'_i v'_{i+1}$ cannot have distinct colours by ϕ since otherwise v'_i would have α -outdegree 1 too.

Hence, all of the arcs outgoing from v'_i have the same colour. Suppose e.g. that all of the arcs outgoing from v'_1 are coloured 1. Then v'_1 has 1-outdegree 2, and v'_1 and v'_2 are adjacent in the 1-subgraph. For these reasons, all of the arcs outgoing from v'_2 cannot be coloured 1 since otherwise v'_2 would have 1-outdegree 2 too. Then all of the arcs outgoing from v'_2 are coloured 2 by ϕ . Repeating the same argument from the left to the right of \vec{F}_2 , we get that v'_i has 1-outdegree 2 for every odd i , while v'_i has 2-outdegree 2 otherwise, i.e. when i is even. Furthermore, every two consecutive outputs of \vec{F}_2 have distinct colours. \square

We now generalize the notion of k -fiber gadget for every $k \geq 3$. Consider any value of k such that every i -fiber gadget has been defined for every $i \in \{2, 3, \dots, k-1\}$. Start from a directed path $\vec{v}'_1 v'_2 \dots v'_x v'_{x+1}$ for some arbitrary value of x . For every v'_i with $i \in \{1, 2, \dots, x\}$, add arcs from v'_i towards $k-1$ new vertices with outdegree 0. Call v_i one such resulting vertex. Finally, identify v'_i with the heads of one distinct even output and one distinct odd output of each of $\vec{F}_2, \vec{F}_3, \dots, \vec{F}_{k-1}$. Refer to Figure 2 for an illustration of the 3-fiber gadget \vec{F}_3 . Similarly as for \vec{F}_2 , we refer to the arcs $\vec{v}'_i v_i$ of \vec{F}_k as its

outputs, making again the distinction between even and odd outputs. The generalized fiber gadgets share a similar colouring property as \vec{F}_2 .

Lemma 11. *In every locally irregular 2-arc-colouring ϕ of \vec{F}_k , all of the even outputs of \vec{F}_k have the same colour, while all of the odd outputs have the second colour. Besides, for every output $\vec{v'_i v_i}$ of \vec{F}_k , the vertex v'_i has outdegree k in the $\phi(\vec{v'_i v_i})$ -subgraph.*

Proof. The proof is similar to the one of Lemma 10. Consider every vertex v'_i of \vec{F}_k . Since the heads of one even output and one odd output of \vec{F}_j are identified with v'_i for every $j \in \{2, 3, \dots, k-1\}$, there are two vertices w_1 and w_2 neighbouring v'_i such that:

- w_1 and v'_i are adjacent in the 1-subgraph induced by ϕ ,
- w_2 and v'_i are adjacent in the 2-subgraph induced by ϕ ,
- w_1 has 1-outdegree j and w_2 has 2-outdegree j .

Since this observation holds for every $j \in \{2, 3, \dots, k-1\}$, note that all the arcs outgoing from v'_i must have the same colour by ϕ since otherwise v'_i would have the same outdegree as one of its neighbours in either the 1- or 2-subgraph. Assume all the arcs outgoing from v'_1 have colour 1 by ϕ without loss of generality. Then all arcs outgoing from v'_2 cannot all be coloured 1 since otherwise v'_1 and v'_2 would be adjacent vertices with outdegree k in the 1-subgraph. Then all arcs outgoing from v'_2 have colour 2 by ϕ . Again, by repeating this argument from left to right, similarly as in the proof of Lemma 10, we get that the colours of the outputs of \vec{F}_k alternate between 1 and 2, and that the tail of each output has α -outdegree k , where α is the colour of this output by ϕ . \square

The generalized fiber gadgets described above are actually not all necessary to prove our main result, but using these we can “generate” vertices with arbitrarily large outdegree in either the 1- or 2-subgraph induced by a locally irregular 2-arc-colouring of some oriented graph. Used conveniently (note in particular that if we identify the heads of one even output and one odd output of, say, \vec{F}_2 , with a vertex v , then v cannot have outdegree 2 in the 1- and 2-subgraphs by some locally irregular 2-arc-colouring), one can construct arbitrarily many oriented graphs with various structures and which have irregular chromatic index 3. This should convince the reader that even if Conjecture 1 turned out to be true, oriented graphs with irregular chromatic index 2 do not have a predictable structure.

We are now ready to prove the main result of this section.

Theorem 12. LOCALLY IRREGULAR 2-ARC-COLOURING is *NP-complete*.

Proof. Clearly LOCALLY IRREGULAR 2-ARC-COLOURING is in **NP** since, given a 2-arc-colouring of \vec{G} , one can easily check whether the two subgraphs of \vec{G} it induces are locally irregular (this property can be checked in quadratic time).

We now prove that LOCALLY IRREGULAR 2-ARC-COLOURING is **NP-hard**, and thus **NP-complete** since it is also in **NP**, by reduction from the following well-known **NP-hard** problem [5].

NOT-ALL-EQUAL 3-SATISFIABILITY

Instance: A 3CNF formula F over variables x_1, x_2, \dots, x_n and clauses C_1, C_2, \dots, C_m .

Question: Is F *nae-satisfiable*, i.e. does there exist a truth assignment to the variables of F such that every clause of F has at least one true and one false literal?

NOT-ALL-EQUAL 3-SATISFIABILITY is notoriously hard, even in its monotone form, i.e. when restricted to instances with no negated variable [5]. We hence suppose throughout this proof that every of its instances, i.e. every formula F , has no negated variable.

From F , we construct an oriented graph \vec{G}_F such that

$$\begin{aligned} & F \text{ is nae-satisfiable} \\ & \Leftrightarrow \\ & \vec{G}_F \text{ admits a locally irregular 2-arc-colouring } \phi_F. \end{aligned}$$

We design \vec{G}_F in such a way that the propagation of ϕ_F along \vec{G}_F is representative of the constraints attached to NOT-ALL-EQUAL 3-SATISFIABILITY, i.e. of the consequences on F of setting such or such variable of F to *true*. This is typically done by designing gadgets with specific colouring properties. Throughout this proof, colour 1 of ϕ_F must be thought of as the truth value *true*, while colour 2 represents the truth value *false* of a truth assignment to the variables of F (one could actually switch these two equivalences as we are dealing with NOT-ALL-EQUAL 3-SATISFIABILITY).

The first requirement of NOT-ALL-EQUAL 3-SATISFIABILITY we have to “translate” is that every clause of F is considered satisfied if and only if it has at least one true and one false variable. This is done by “transforming” every clause $C_j = (x_{i_1} \vee x_{i_2} \vee x_{i_3})$ into some clause gadget $\vec{G}_F(C_j)$ in \vec{G}_F with three special arcs \vec{a}_1, \vec{a}_2 and \vec{a}_3 representing the variables of C_j , and such that all of these three arcs cannot have the same colour by ϕ_F . Assuming that, say, $\phi_F(\vec{a}_1) = 1$ (resp. $\phi_F(\vec{a}_1) = 2$) simulates the fact that x_{i_1} supplies C_j with value *true* (resp. *false*), the requirement above then follows naturally from the colouring property of $\vec{G}_F(C_j)$.

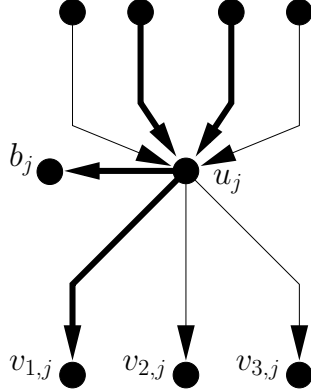

Figure 3: The clause gadget $\overrightarrow{G}_F(C_j)$, where the top-most arcs are outputs of the 3- and 4-fiber gadgets \overrightarrow{F}_3 and \overrightarrow{F}_4 , and a locally irregular 2-arc-colouring of $\overrightarrow{G}_F(C_j)$ (thick (resp. thin) arcs are arcs coloured 1 (resp. 2)).

Consider then every clause $C_j = (x_{i_1} \vee x_{i_2} \vee x_{i_3})$, whose some variables may be the same. The clause gadget $\overrightarrow{G}_F(C_j)$, associated with C_j , is obtained as follows (see Figure 3). Add five vertices $u_j, v_{1,j}, v_{2,j}, v_{3,j}$ and b_j to \overrightarrow{G}_F , as well as all arcs from u_j towards every vertex in $\{v_{1,j}, v_{2,j}, v_{3,j}, b_j\}$. Now identify u_j with the heads of one even output and one odd output of each of \overrightarrow{F}_3 and \overrightarrow{F}_4 , where \overrightarrow{F}_3 and \overrightarrow{F}_4 are the 3- and 4-fiber gadgets. The arcs $\overrightarrow{a_1}, \overrightarrow{a_2}$ and $\overrightarrow{a_3}$ mentioned in the explanations above actually refer to $\overrightarrow{u_j v_{1,j}}, \overrightarrow{u_j v_{2,j}}$ and $\overrightarrow{u_j v_{3,j}}$. Besides, one has to think of every vertex $v_{i,j}$ as a vertex associated with the i^{th} variable of C_j . We show that $\overrightarrow{G}_F(C_j)$ cannot have all of its arcs $\overrightarrow{u_j v_{1,j}}, \overrightarrow{u_j v_{2,j}}$ and $\overrightarrow{u_j v_{3,j}}$ having the same colour by ϕ_F , as required.

Claim 1. *Let C_j be a clause of F , with $j \in \{1, 2, \dots, m\}$. Then one arc of $\overrightarrow{u_j v_{1,j}}, \overrightarrow{u_j v_{2,j}}$ and $\overrightarrow{u_j v_{3,j}}$ has some colour by ϕ_F , while the other two arcs have the second colour.*

Proof. The claim follows from the facts that u_j has outdegree 4 and is adjacent to vertices with outdegree 3 and 4 in both the 1- and 2-subgraphs induced by ϕ_F , namely the tails of some outputs of \overrightarrow{F}_3 and \overrightarrow{F}_4 whose heads were identified with u_j . \square

The second requirement of NOT-ALL-EQUAL 3-SATISFIABILITY we have to model is that, by a truth assignment of the variables of F , a variable provides the same truth value to every clause it appears in. At the moment, this requirement is not met as ϕ_F may be locally irregular but with, say, $\phi_F(\overrightarrow{u_j v_{i,j}}) = 1$ and $\phi_F(\overrightarrow{u_{j'} v_{i',j'}}) = 2$ with the i^{th} variable of C_j being identical

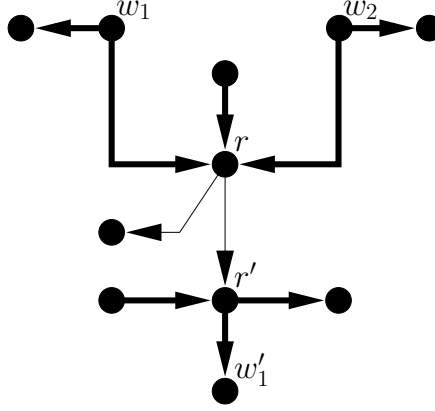

Figure 4: The collecting gadget $\overrightarrow{G^r}$, and a locally irregular 2-arc-colouring of $\overrightarrow{G^r}$ (thick (resp. thin) arcs are arcs coloured 1 (resp. 2)).

to the i^{th} variable of $C_{j'}$, say x_ℓ . Following our analogy above, this would simulate that x_ℓ belongs to both of the clauses C_j and $C_{j'}$, but x_ℓ provides *true* to C_j and *false* to $C_{j'}$ by a truth assignment, which is impossible. Hence, we have to check somehow whether all the arcs $\overrightarrow{u_{j_1}v_{i_1,j_1}}$, $\overrightarrow{u_{j_2}v_{i_2,j_2}}$, ..., $\overrightarrow{u_{j_{n_i}}v_{i_{n_i},j_{n_i}}}$, representing the membership of x_ℓ to the clauses $C_{j_1}, C_{j_2}, \dots, C_{j_{n_i}}$ of F that contain x_ℓ , have the same colour by ϕ_F .

This is done by using the *collecting* gadget $\overrightarrow{G^r}$ depicted in Figure 4. The arcs $\overrightarrow{w_1r}$ and $\overrightarrow{w_2r}$ are called the *inputs* of $\overrightarrow{G^r}$, while $\overrightarrow{r'w'_1}$ is its *output*. Note that w_1, w_2 and r' have outdegree 2. This gadget $\overrightarrow{G^r}$ has the following colouring property.

Claim 2. *Let ϕ be a locally irregular 2-arc-colouring of $\overrightarrow{G^r}$ such that the two arcs outgoing from w_1 have the same colour, and the two arcs outgoing from w_2 have the same colour. Then $\phi(\overrightarrow{w_1r}) = \phi(\overrightarrow{w_2r}) = \phi(\overrightarrow{r'w'_1})$.*

Proof. Assume $\phi(\overrightarrow{w_1r}) = 1$ and $\phi(\overrightarrow{w_2r}) = 2$ without loss of generality. In particular, note that w_1 and r are adjacent in the 1-subgraph, and that w_2 and r are adjacent in the 2-subgraph. Besides, by assumption w_1 has 1-outdegree 2 while w_2 has 2-outdegree 2. For these reasons, note that the two arcs outgoing from r cannot have the same colour since otherwise r would have 1- or 2-outdegree 2, a contradiction. Then one arc outgoing from r has colour 1 by ϕ while the other arc has colour 2, implying that r has both 1- and 2-outdegree 1. But then we necessarily get a contradiction while colouring the arc outgoing from the vertex with outdegree 1 attached to r .

On the contrary, note that if $\phi(\overrightarrow{w_1r}) = \phi(\overrightarrow{w_2r}) = 1$ without loss of generality, then, so that we avoid every contradiction mentioned above, we

have to colour 2 all arcs outgoing from r . Then r and r' are neighbouring vertices in the 2-subgraph, and r has 2-outdegree 2. Since there is a vertex with outdegree 1 attached to r' , again we cannot colour the two arcs outgoing from r' with distinct colours. Then we have to colour 1 the two arcs outgoing from r' . \square

Roughly speaking, assuming we are given two arcs \vec{a}_1 and \vec{a}_2 whose tails necessarily have outdegree 2 in the $\phi_F(\vec{a}_1)$ - and $\phi_F(\vec{a}_2)$ -subgraphs, respectively, we can “check” whether $\phi_F(\vec{a}_1) = \phi_F(\vec{a}_2)$. Namely, take a copy of \vec{G}^{\checkmark} and “replace” the arcs $\vec{w}_1\vec{r}$ and $\vec{w}_2\vec{r}$ with \vec{a}_1 and \vec{a}_2 , respectively. We refer to this operation as *collecting* \vec{a}_1 and \vec{a}_2 (with some copy of \vec{G}^{\checkmark}). According to Claim 2, the arc-colouring ϕ_F cannot then be extended to the collecting gadget if $\phi_F(\vec{a}_1) \neq \phi_F(\vec{a}_2)$. Recall further that if $\phi_F(\vec{a}_1) = \phi_F(\vec{a}_2)$, then all of the arcs outgoing from the tail of the output of the collecting gadget have colour $\phi_F(\vec{a}_1)$, and the tail of the output thus has $\phi_F(\vec{a}_1)$ -outdegree 2. In some sense, this property means that the output of a collecting gadget “memorizes” the colour used at its two inputs.

To end up the construction of \vec{G}_F , proceed as follows. Consider every variable x_i of F with $i \in \{1, 2, \dots, n\}$, and let $\vec{o}_1, \vec{o}_2, \dots, \vec{o}_{n_i}$ denote the n_i arcs of \vec{G}_F representing the membership of x_i to some clause, where n_i is the number of clauses that contain x_i . More precisely, these arcs are of the form $\vec{u}_j v_{i',j}$, where $i' \in \{1, 2, 3\}$ and $j \in \{1, 2, \dots, m\}$, and x_i is the i^{th} variable of C_j . Recall further that if any of these arcs \vec{o} is coloured, say, 1 by ϕ_F , then the tail of \vec{o} has 1-outdegree 2. Start by collecting \vec{o}_1 and \vec{o}_2 with a copy \vec{G}_1 of \vec{G}^{\checkmark} . Then collect the output of \vec{G}_1 and \vec{o}_3 with a new copy \vec{G}_2 of \vec{G}^{\checkmark} . Then collect the output of \vec{G}_2 and \vec{o}_4 with a new copy \vec{G}_3 of \vec{G}^{\checkmark} . And so on. This procedure uses $n_i - 1$ copies of \vec{G}^{\checkmark} .

We claim that we have the desired equivalence between nae-satisfying F and finding a locally irregular 2-arc-colouring ϕ_F of \vec{G}_F . If ϕ_F exists, then for each clause $C_j = (x_{i_1} \vee x_{i_2} \vee x_{i_3})$, one arc of $u_j v_{1,j}, u_j v_{2,j}, u_j v_{3,j}$ has some colour by ϕ_F while the other two arcs have the other colour (Claim 1). Besides, this arc-colouring, because of the collecting gadgets, has the property that all arcs corresponding to the membership of a same variable to some clauses have the same colour (Claim 2). Assuming having $\phi_F(\vec{u}_j v_{i',j}) = 1$ (resp. $\phi_F(\vec{u}_j v_{i',j}) = 2$) simulates the fact that the i^{th} variable of C_j is set to *true* (resp. *false*), we can directly deduce a truth assignment nae-satisfying F from ϕ_F , and vice-versa. This completes the proof. \square

5 Conclusion and open questions

Conjecture 1 remains the most important open question at the moment. Maybe the strategy we proposed in Section 3 could be refined to slightly improve Theorem 9, e.g. by showing that every oriented graph can be decomposed into two subgraphs with irregular chromatic index at most 2 and 3, respectively, or two subgraphs with irregular chromatic index at most 2 plus some isolated arcs, etc. However, we do not think that Conjecture 1 can be tackled using this method.

In particular, it is worth mentioning that Theorem 4 is tight since there are acyclic oriented graphs with irregular chromatic index exactly 3 (so we cannot improve Theorem 9 from 6 to 4 by just improving Theorem 4). To be convinced of this statement, one just has to note that **LOCALLY IRREGULAR 2-ARC-COLOURING** remains **NP-complete** when restricted to acyclic oriented graphs as it can be easily checked that the reduction in the proof of Theorem 12 actually provides acyclic oriented graphs.

It is worth adding that we were not able to prove that Conjecture 1 holds when restricted to tournaments. Although the question can be handled easily for some restricted families of tournaments, e.g. transitive tournaments (which are locally irregular), we could not find any argument for the general case. Until a proof of Conjecture 1 is exhibited, which would solve the problem, we raise the following weaker conjecture.

Conjecture 13. *For every tournament \vec{T} , we have $\chi'_{irr}(\vec{T}) \leq 3$.*

References

- [1] Y. Alavi, G. Chartrand, F.R.K. Chung, P. Erdős, R.L. Graham, and O.R. Oellermann. How to define an irregular graph. *J. Graph Theory*, 11(2):235–249, 1987.
- [2] O. Baudon, J. Bensmail, J. Przybyło, and M. Woźniak. On decomposing regular graphs into locally irregular subgraphs. *Preprint MD 065*, <http://www.ii.uj.edu.pl/preMD/index.php>, 2013.
- [3] G. Chartrand, M.S. Jacobson, J. Lehel, O.R. Oellermann, S. Ruiz, and F. Saba. Irregular networks. *Congress. Numer.*, 64:197–210, 1988.
- [4] R. Diestel. *Graph Theory*, volume 173 of *Graduate Texts in Mathematics*. Springer-Verlag, Heidelberg, third edition, 2005.
- [5] M.R. Garey and D.S. Johnson. *Computers and Intractability: A Guide to the Theory of NP-Completeness*. W. H. Freeman, 1979.

- [6] W. Imrich and S. Klavžar. *Product Graphs: Structure and Recognition*. Wiley-Interscience, New York, 2000.
- [7] M. Karoński, T. Łuczak, and A. Thomason. Edge weights and vertex colours. *J. Combin. Theory, Ser. B*, 91(1):151 – 157, 2004.