

Influence of IGBT Current Rating on the Thermal Cycling Lifetime of a Power Electronic Active Rectifier in a Direct Wave Energy Converter

Thibaut Kovaltchouk¹, Judicaël Aubry², Bernard Multon¹, Hamid Ben Ahmed¹

¹SATIE, ENS Cachan Brittany Branch UEB, Bruz, France

²Mechatronics team, ESTACA Laval, France

Context: Reliability in Wave Energy Converters

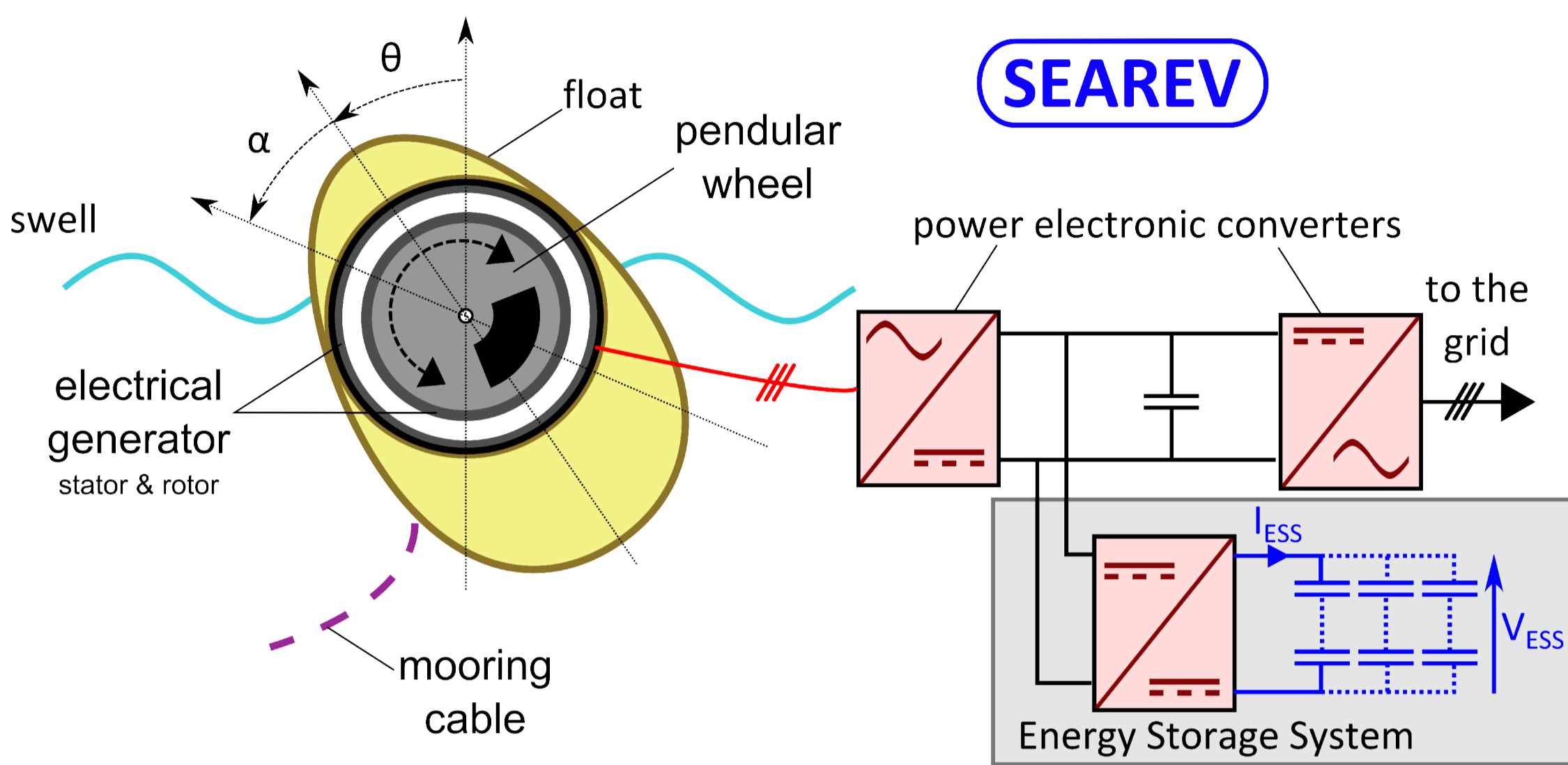

Principle scheme of the SEAREV Direct Wave Energy Converter

Reliability in Wave Energy Converters (WEC) constitutes a key issue for two main reasons. First of all, maintenance operations are restricted due to few weather window opportunities in energetically attractive sites. Secondly mechanical and electrical power fluctuations are strong and frequent during wave energy conversion, especially in a **Direct Wave Energy Converter (DWEC)**, for which wave power fluctuations lead directly to fluctuations in the electrical power produced.

A power electronic converter must offer a tradeoff between cost, size, reliability and performance over the entire operating lifetime (considered to be 20 years in this case). Most recent aging models have provided statistical information and taken into account the various failure modes. It can help the sizing of the IGBT cells and the heatsink.

From a sea elevation profile to junction temperature waveforms

A **multiphysics model** is used to compute current waveforms in the power electronic components from a sea elevation profile. The hydro-mechanical part of the model computes both speed and torque at the PMSG shaft based on the sea elevation profile and a damping law. The electrical model yields voltages and currents in the machine based on torque-speed profiles.

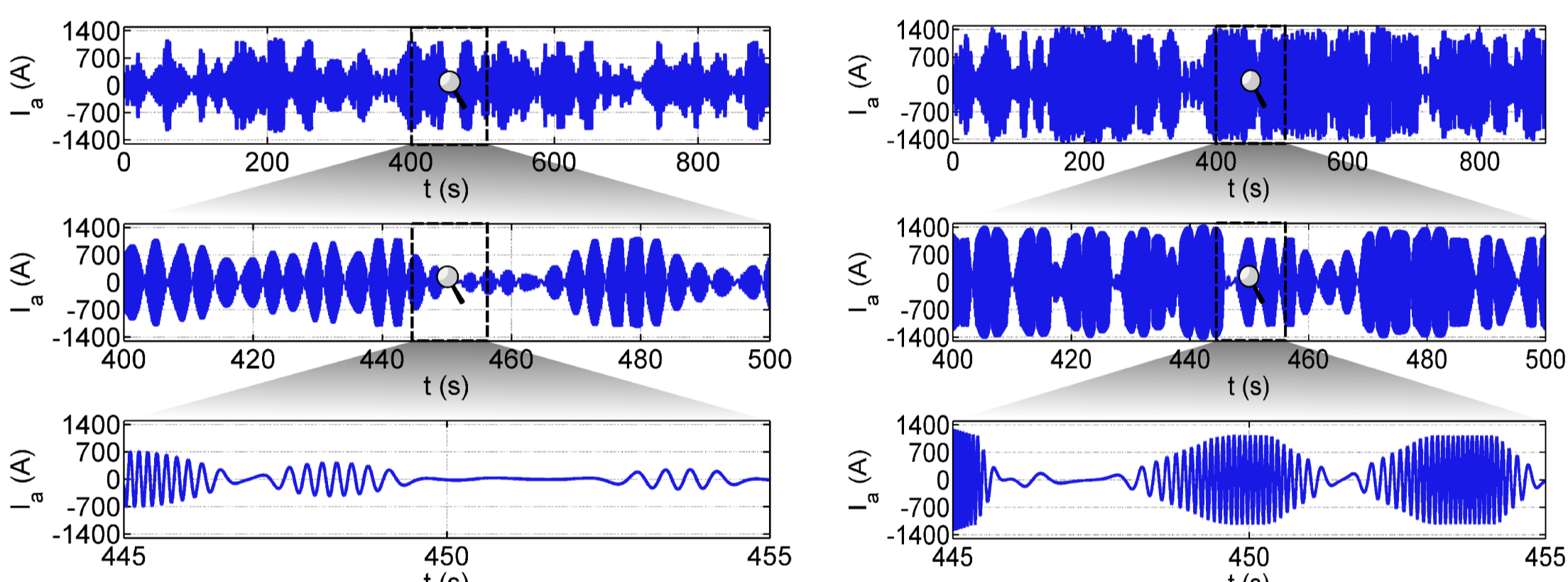

Current waveforms in the first phase of the PMSG vs. time in two sea-state examples: an energetically dominant sea-state (left) and a very powerful sea-state (right)

The losses are calculated as **averages over the modulation period**. They depend on the rated current of IGBTs and diodes and give the heat sources for the thermal model.

$$P_{cond IGBT} = (V_{0IGBT}^* + r_{dIGBT}^* I_c) I_f d_{IGBT}$$

$$P_{sw IGBT} = f_d E_{IGBTref}^* \left(\frac{I_c}{I_{ref}} \right)^{1.1} \left(\frac{V_{DC}}{V_{DCref}} \right)^{1.35}$$

$$P_{cond Diode} = (V_{0Diode}^* + r_{dDiode}^* I_f) I_f d_{Diode}$$

$$P_{sw Diode} = f_d E_{Diode}^* \left(\frac{I_f}{I_{ref}} \right)^{0.6} \left(\frac{V_{DC}}{V_{DCref}} \right)^{0.6}$$

Conduction losses in IGBT and diode with d_x the corresponding duty cycle

Switching losses in IGBT and diode

* V_{0IGBT}^* , r_{dIGBT}^* , V_{0Diode}^* , r_{dDiode}^* , $E_{IGBTref}^*$, E_{diode}^* and I_{ref} are function of current rating.

Foster's network model is used to build the junction-case thermal model.

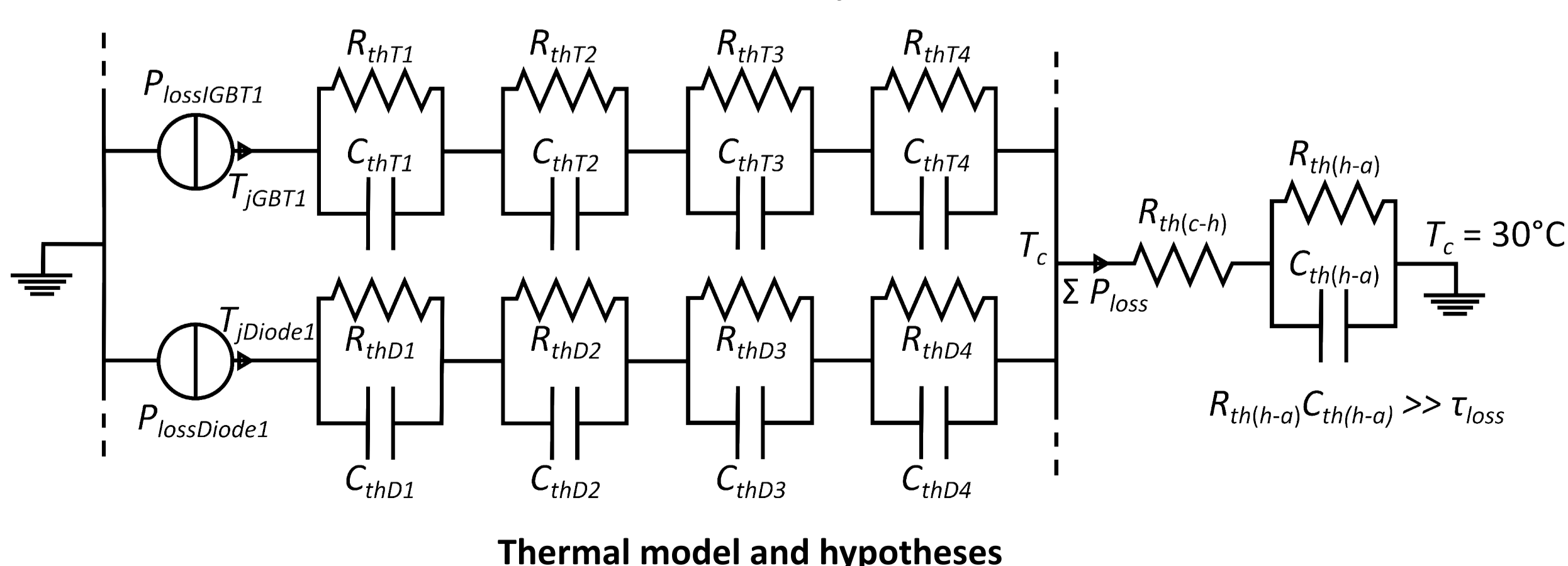

Thermal model and hypotheses

X	V_{0x}	r_{dx} / I_{rated}	$E_x (I_{rated}, 900 V) / I_{rated}$	$R_{th(j-c)} / I_{rated}$	$R_{th(c-h)} / I_{rated}$
IGBT	1.17 V	1.37 $\Omega \cdot A$	0.695 mJ/A	16.7 (K/W)·A	2.12 (K/W)·A
Diode	0.97 V	0.69 $\Omega \cdot A$	1.17 mJ/A	29.4 (K/W)·A	

Loss and thermal model parameters as a function of current rating for ABB HiPak™ 1700 V Soft-Punch-Through technology (parallel connection of 100 A chips)

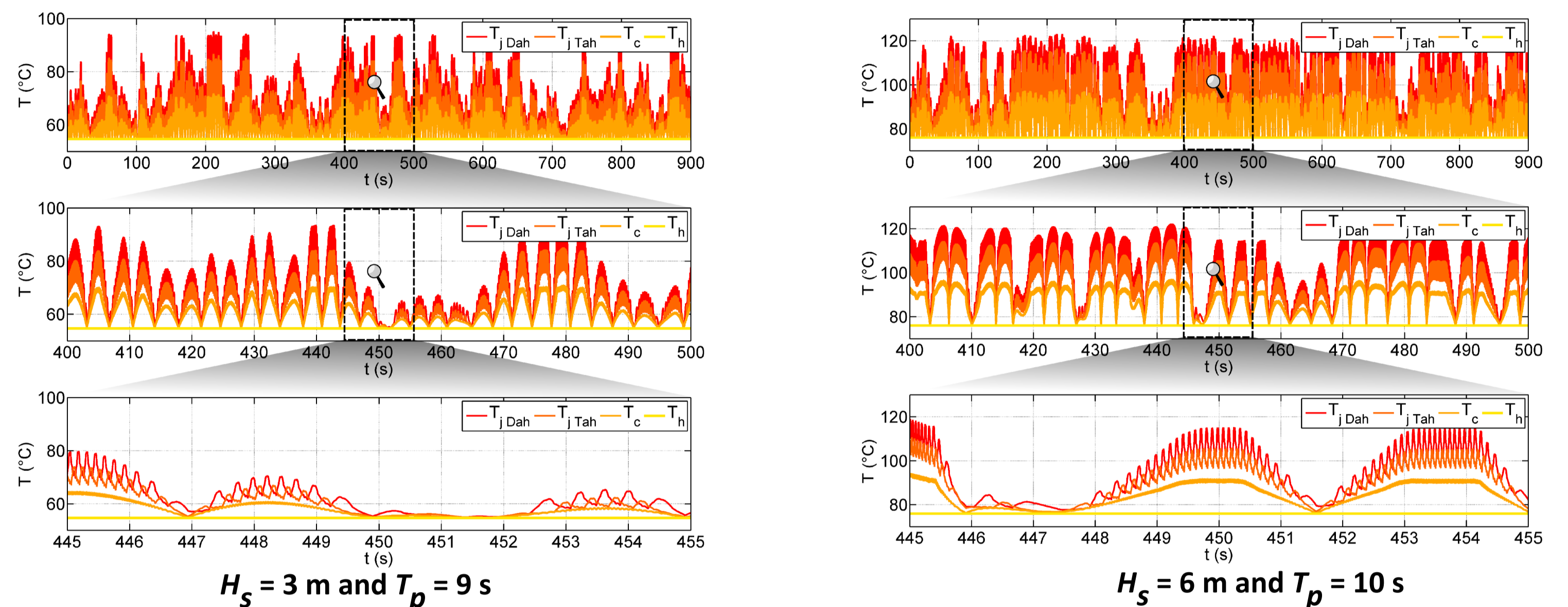

Junction, case and heatsink temperature waveforms for a rated current of 1400 A and heatsink thermal resistance of 7 K/kW in two sea-state examples: an energetically dominant sea-state (left) and a very powerful sea-state (right)

Reliability model of IGBT

Thermal aging models have been built with a **cyclic pattern** of thermal junction temperature. This model's primary assumption is that an aging cycle with a different shape yet the same amplitude, same maximum (or minimum) temperature and same duration causes the same level of damage. A comprehensive model is given by ABB [Load-cycling capability of HiPak™ IGBT modules, E. Özkol, S. Hartmann and H. Duran, 2012].

$$N_{10\%wb} = \begin{cases} 8.56e8 (\Delta T_j - \Delta T_{jcut-off})^{-2} & \text{if } \Delta T_j > \Delta T_{jcut-off} \\ +\infty & \text{if } \Delta T_j \leq \Delta T_{jcut-off} \end{cases}$$

$$N_{10\%sj} = 3.33e141 \times t_{cycle}^{-1.93} T_{jmin}^{-42.2} \Delta T_j^{-15.4} + 1.31e23 \times t_{cycle}^{-0.207} T_{jmin}^{-4.52} \Delta T_j^{-3.29}$$

with $\Delta T_{jcut-off} = 148 - 0.308 T_{jmax}$

Wire bonding cycling based fatigue model

Chip solder joint cycling based fatigue model

$N_{10\%X}$ represents the number of cycles when the probability of failure reaches 10 %.

The **rainflow-counting algorithm** transforms time series into various cycles in order to apply cycling aging models in the case of complex loadings. To associate a damage with a complex loading, the **Miner's cumulative damage rule**.

The distribution of failures follows a **Weibull distribution** for both models, which in turn allows calculating failure probability.

$$F_x(t) = 1 - \exp \left(\ln(0.9) \left(\frac{t}{t_{10\%X}} \right)^{\beta_x} \right)$$

Weibull distribution to calculate failure probability as a function of time

Results

Sea-state	$t_{10\%wb IGBT}$ (IGBT wire bonding)	$t_{10\%sj IGBT}$ (IGBT solder joint)	$t_{10\%wb Diode}$ (Diode wire bonding)	$t_{10\%sj Diode}$ (Diode solder joint)
$H_s = 3$ m; $T_p = 9$ s	> 30 years (∞)	> 30 years (160 years)	> 30 years (160 years)	14 years
$H_s = 6$ m; $T_p = 10$ s	16 years	5.4 years	2.4 years	2.0 years

Single-module lifetime prediction for two sea-state examples with a rated current of 1400 A and a heatsink temperature resistance of 7 K/kW in two sea-state examples: an energetically dominant sea-state and a very powerful sea-state

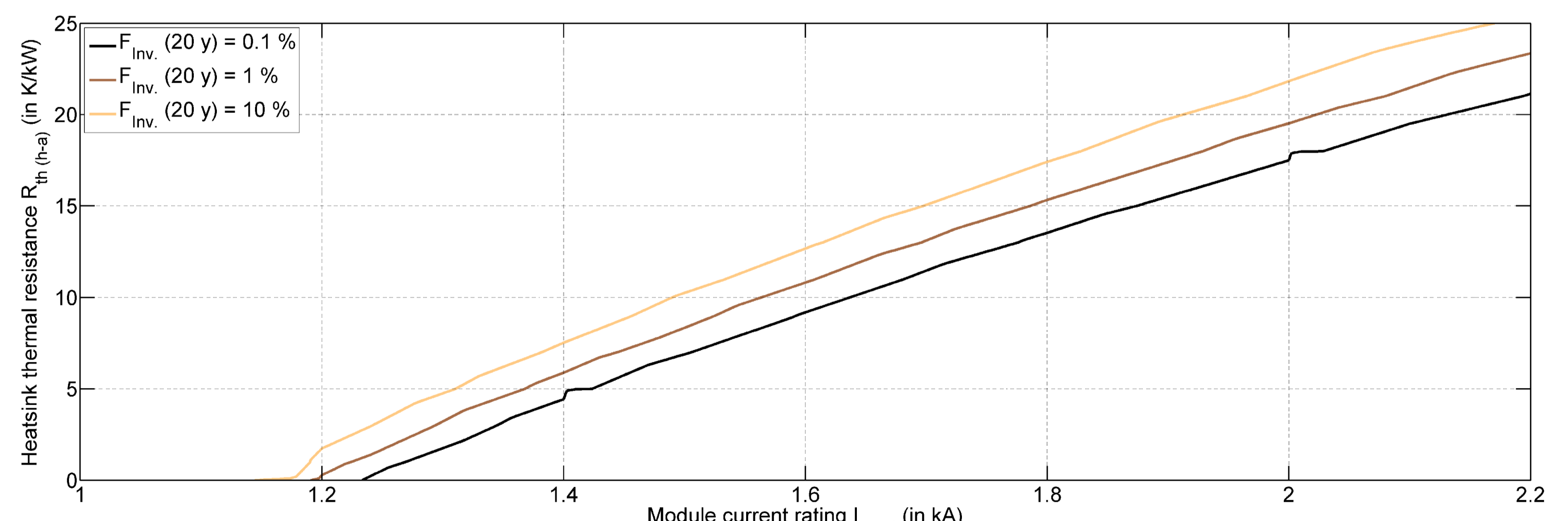

Iso-failure probability at 20 years for the 6 module (complete active rectifier) in all sea-states as a function of both the heatsink thermal resistance and semiconductor current rating. The 106 sea-states probabilities of apparition are related to the French island of Yeu.

Clearly, a small oversizing of modules ($\approx +10\%$) allows the failure rate to drop from 10 % to 0.1 % (gain of a factor 100).

Others failures causes must be investigated (capacitors, gate drives, connectors,...) in power electronic converters. However, this lifetime analysis allows the optimization of the semiconductor module size.

This work has been financed by the French National Research Agency (ANR) within the project "QUALIPHE" (power quality and grid integration of direct wave energy converters), which is part of the "PROGELEC" program.