



**HAL**  
open science

## An example of integrated approach for the technical and economic optimization of maintenance

Emmanuel Rémy, Franck Corset, Stéphane Despréaux, Laurent Doyen, Olivier Gaudoin

► **To cite this version:**

Emmanuel Rémy, Franck Corset, Stéphane Despréaux, Laurent Doyen, Olivier Gaudoin. An example of integrated approach for the technical and economic optimization of maintenance. *Reliability Engineering and System Safety*, 2013, 116, pp.8–19. 10.1016/j.ress.2013.02.001 . hal-00850427

**HAL Id: hal-00850427**

**<https://hal.science/hal-00850427>**

Submitted on 10 May 2023

**HAL** is a multi-disciplinary open access archive for the deposit and dissemination of scientific research documents, whether they are published or not. The documents may come from teaching and research institutions in France or abroad, or from public or private research centers.

L'archive ouverte pluridisciplinaire **HAL**, est destinée au dépôt et à la diffusion de documents scientifiques de niveau recherche, publiés ou non, émanant des établissements d'enseignement et de recherche français ou étrangers, des laboratoires publics ou privés.

# An example of integrated approach to technical and economic optimization of maintenance

Emmanuel Remy<sup>a</sup>, Frank Corset<sup>b</sup>, Stéphane Despréaux<sup>b</sup>, Laurent Doyen<sup>b</sup>, Olivier Gaudoin<sup>b</sup>

<sup>a</sup>EDF R&D - Industrial Risk Management Department, 6 quai Watier, 78401 Chatou Cedex, France

<sup>b</sup>Grenoble University - Jean Kuntzmann Laboratory, BP 53, 38041 Grenoble Cedex 9, France

---

## Abstract

This paper presents a case study of technical and economic optimization of the periodicity of predetermined preventive maintenance actions carried out on a repairable industrial system from an EDF electric power plant. This analysis is conducted with the MARS software tool (MARS for "Maintenance Assessment of Repairable Systems"), developed jointly by Grenoble University and EDF R&D. The innovative aspect of this work lies in the integrated approach that is used, combining two steps. A first estimation step retrospectively assesses maintenance effect on system reliability. A second simulation step predicts the behaviour of the maintained system over the time period set as an objective by the operator.

*Keywords:* Repairable systems reliability, Imperfect repair, Maintenance efficiency, Maintenance optimization, Failure intensity, Non-homogeneous Poisson process, Ageing

---

## 1. Introduction

Maintenance is carried out on repairable industrial systems throughout their life cycle to keep them in, or restore them to, an operating state, while ensuring constraints related to safety, availability and costs. Maintenance, by providing an essential contribution to the operational system reliability, plays a great part in risk management and constitutes a crucial element in the performance of an industrial installation. That is why the quantitative assessment of maintenance effect and its optimization are major strategic challenges for an energy utility company such as EDF, which is a leading player in the European energy industry. From a practical point of view, the process consisting in evaluating then optimizing maintenance efficiency is made of two main successive and eventually iterative steps.

- Step (A) Once the initial maintenance plan is devised and effectively carried out on the system, one must retrospectively confirm its real quality, according to the constraints and objectives initially set by the operator. In order to estimate the intrinsic system reliability and the maintenance efficiency, the data related to the events observed during the system operation (deteriorations, failures and/or survivals) is required. Then one can decide if it is necessary to revise the maintenance plan. Depending on the results of this evaluation, either the maintenance plan remains unchanged if satisfactory or is modified, in which case one moves on to the next step.
- Step (B) If the maintenance plan must (or can) be optimized, for instance by adjusting the frequency of the periodic preventive maintenance actions, one must assess the possible consequences of the considered changes before the modifications are applied, in order to check if the new maintenance plan will be more efficient than the current one, for example on technical and economic criteria. To that

end, simulation techniques must be carried out to determine the potential impact of the upcoming maintenance plan over the time period set as an objective by the operator. These techniques consist in reproducing the future behaviour of the system on the basis of its intrinsic reliability and the efficiency of the maintenance actions previously estimated in step (A).

Thus, as presented in Figure 1, the process which leads to the assessment of the maintenance effect on the system reliability can be seen as an iterative sequence of the two previous steps.

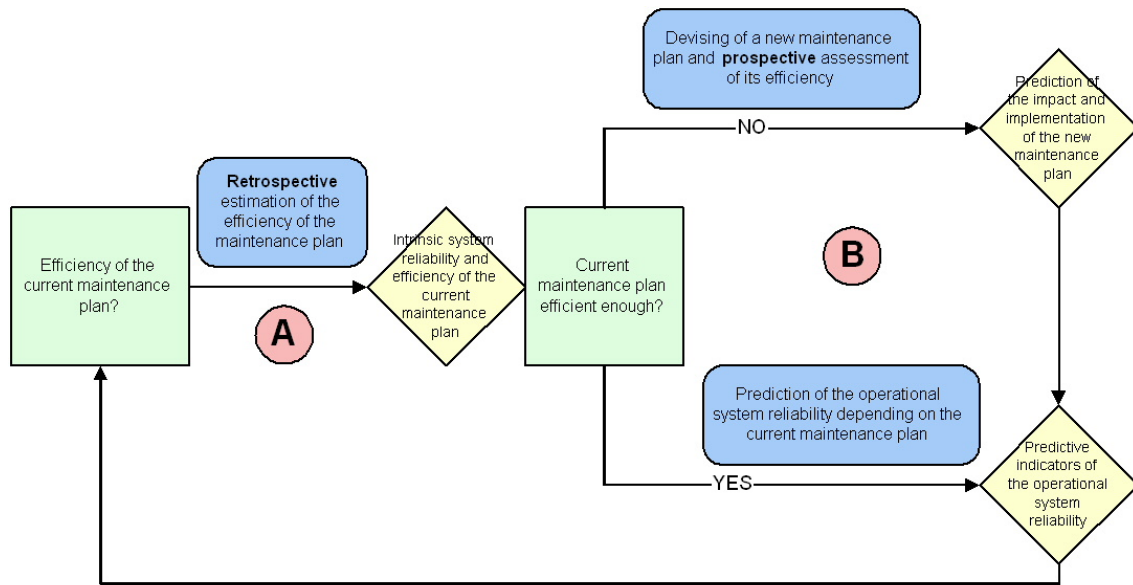

Figure 1: Process consisting in evaluating then optimizing maintenance efficiency

In order to help the plant operator to define efficient maintenance plans, Grenoble University and EDF R&D developed a software tool to the attention of reliability engineers. This software, called MARS for "Maintenance Assessment of Repairable Systems" [1], is an innovative and user-friendly freeware that offers an integrated approach to the whole process of maintenance assessment and optimization previously described. Indeed, by implementing imperfect maintenance models and methods for statistical estimation and stochastic simulation, MARS allows to easily carry out both steps (A) and (B) and thus:

- on the one hand, to estimate the intrinsic wear-out of the system and to assess maintenance effect on system reliability, in order to retrospectively check if the effective maintenance plan reaches the initially set objectives,
- on the other hand, to carry out studies in order to optimize the frequency of the predetermined preventive maintenance in a prospective way.

The aim of this paper is to present the details of this integrated approach and to underline its advantages on an industrial case study. Sections 2 and 3 present theoretical elements about the modelling of maintenance process and the estimation of intrinsic system behaviour and maintenance effect. The case study, carried out on a repairable industrial system from an EDF electric power plant, is presented in depth in Sections 4

to 7. The industrial context and the available OF data are described in Section 4. The probabilistic models considered for the case study, the statistical estimation of their parameters and the calculation of predictive reliability indicators are tackled in Section 5, while uncertainty estimation evaluation is discussed in Section 6. Finally, the numerical results obtained with MARS for the prospective optimization of the periodicity of PM actions are presented in Section 7.

## 2. Maintenance process modelling

Let us consider a maintained industrial system and assume that a Corrective Maintenance (CM) action, or repair, is carried out systematically after each failure. The repair times are supposed to be negligible or not taken into account. Thus the successive random failure times, denoted  $T_i, i \geq 1$ , are equivalently the successive CM times. Let  $X_i, i \geq 1$ , denote the inter-failure times, that is to say  $X_i = T_i - T_{i-1}$  with  $T_0 = 0$ , and  $N_t, t \geq 0$ , the (cumulative) number of failures observed up to time  $t$ . First, let us consider that only CM is carried out on the system. In Section 2.6 we will present the generalization of the models to take into account Preventive Maintenance (PM). From a mathematical point of view,  $\{N_t\}_{t \geq 0}$  is a stochastic point process, fully characterized by its failure intensity defined as [2]:

$$\lambda_t = \lim_{\Delta t \rightarrow 0} \frac{1}{\Delta t} \mathbb{P}(N_{t+\Delta t} - N_{t-} = 1 | T_1, T_2, \dots, T_{N_{t-}}), t \geq 0 \quad (1)$$

where  $N_{t-}$  is the left hand limit of  $N_t$ . Before the first maintenance action, the system failure intensity is the failure rate of a new and non-maintained system. The failure rate is assumed to be a deterministic and continuous function of time, called the initial intensity and denoted  $\lambda(t)$ : it characterizes the intrinsic system reliability, that is to say the one the system would have if it was not maintained. In order to model a continuous behaviour of a system without maintenance, it is usual to consider a Weibull distribution for the first failure time, so that the initial intensity is a power of time  $\lambda(t) = \alpha \beta t^{\beta-1}, t \geq 0$ , where  $\alpha > 0$  is the scale parameter and  $\beta > 0$  is the shape parameter characterizing the speed of the system wear-out:

- if  $0 < \beta < 1$ , the state of the system improves with time (burn-in),
- if  $\beta = 1$ , the state of the system remains stable with time (useful life),
- if  $\beta > 1$ , the system wears out.

### 2.1. Minimal repair model

The minimal repair model assumes that the effect of maintenance is to leave the system in the same state as it was just before failure. It characterizes a maintenance effect that neither improves nor damages the system. This one is "As Bad As Old" (ABAO) after maintenance. Then, the failure process is a standard Non Homogeneous Poisson Process (NHPP), and the failure intensity equals the initial intensity:

$$\lambda_t = \lambda(t), t \geq 0 \quad (2)$$

With an initial intensity of the Weibull type, this failure process is called the Power Law Process (PLP). When  $\beta = 1$ , one comes across the special case of the Homogeneous Poisson Process (HPP). Another usual NHPP model is the log-linear one [2]. More complex initial intensity models can be considered, for instance bathtub shaped models [3] which allow to take into account the three burn-in, useful life and wear-out periods of the system.

## 2.2. Perfect repair model

The perfect repair model assumes that each maintenance action perfectly repairs the system and leaves it as if it was new. The latter is "As Good As New" (AGAN) after maintenance. At time  $t$ , the system is comparable to a similar new system put into operation just after the previous maintenance. The inter-failure times are independent and have the same distribution. The failure process is a Renewal Process (RP) with failure intensity:

$$\lambda_t = \lambda(t - T_{N_{t-}}), t \geq 0 \quad (3)$$

## 2.3. Virtual age models

Obviously standard maintenance reduces failure intensity but does not systematically leave the system as good as new: reality is between the two extreme cases previously presented. In literature, models enabling to take into account a maintenance effect between ABAO and AGAN are known as imperfect maintenance models [4]. Many models have been proposed and the most famous of them are the virtual age models [5]. They are characterized by a sequence  $\{A_i\}_{i \geq 1}$  of positive random variables, with  $A_0 = 0$ , assuming that after the  $i$ -th maintenance action,  $i \geq 1$ , the system behaves as a new one having survived without failing until time  $A_i$ . Thus the failure intensity of a virtual age model is:

$$\lambda_t = \lambda(t - T_{N_{t-}} + A_{N_{t-}}), t \geq 0 \quad (4)$$

$A_i$  is called the effective age of the system after the  $i$ -th maintenance and  $t - T_{N_{t-}} + A_{N_{t-}}$  is called the virtual age of the system at time  $t$ . Therefore the effective age is the virtual age of the system just after repair. The effect of maintenance with this kind of model is to reduce the virtual age of the system. As particular cases of the virtual age model, one comes across the two standard models:

- if  $A_i = T_i$ , maintenance is minimal (ABAO model),
- if  $A_i = 0$ , maintenance is perfect (AGAN model).

There exist several virtual age models with imperfect effect, such as the Arithmetic Reduction of Age models [6] or the Brown-Proschan model [7]. These models present the benefit of differentiating and explicitly characterizing the intrinsic wear-out and the effect of maintenance on the system reliability, which facilitates their physical interpretation, their use in a potential decision process and their appropriation by engineers. Many other imperfect maintenance models, based on different assumption and modelling of the effect of maintenance on the state of the system, have been developed: one can mention the reduction of failure intensity models [6] or the trend-renewal processes [8]. These will not be addressed in this paper.

## 2.4. Arithmetic reduction of age model with infinite memory

The Arithmetic Reduction of Age model with infinite memory, denoted  $ARA_\infty$ , assumes that maintenance reduces the virtual age of the system by an amount which is proportional to its age just before repair [6]. As the virtual age of the system just before the  $i$ -th maintenance,  $i \geq 1$ , is  $T_i - T_{i-1} + A_{i-1}$ , the effective age is:

$$A_i = (T_i - T_{i-1} + A_{i-1}) - \rho(T_i - T_{i-1} + A_{i-1}) = (1 - \rho)(T_i - T_{i-1} + A_{i-1}) \quad (5)$$

where  $\rho$  is the proportionality factor. It can be proved that the failure intensity of the  $ARA_\infty$  model is:

$$\lambda(t) = \lambda \left( t - \rho \sum_{j=0}^{N_{t-}-1} (1 - \rho)^j T_{N_{t-}-j} \right), t \geq 0 \quad (6)$$

This model is a particular Kijima type II model [5] and is the same as the one introduced by Brown et al. [9]. Parameter  $\rho$  characterizes the maintenance efficiency:

- if  $\rho = 1$ , maintenance is perfect (AGAN model),
- if  $0 < \rho < 1$ , maintenance is efficient,
- if  $\rho = 0$ , maintenance is minimal (ABAO model),
- if  $\rho < 0$ , maintenance is harmful and damages the system.

### 2.5. Brown-Proschan model

The Brown-Proschan (BP) model assumes that the system is perfectly repaired (AGAN) with probability  $p$  and minimally repaired (ABAO) with probability  $1-p$  [7]. The effect of maintenance actions is characterized by independent and identically distributed random variables  $B_i$ ,  $i \geq 1$ , following a Bernoulli distribution with parameter  $p$ , equal to 1 if the  $i$ -th repair is AGAN and 0 if it is ABAO. It can be proved that the failure intensity of the BP model is:

$$\lambda(t) = \lambda \left( t - T_{N_t^-} + \sum_{j=1}^{N_t^-} \prod_{k=j}^{N_t^-} (1 - B_k) X_j \right), t \geq 0 \quad (7)$$

Actually the BP model is a virtual age model with:

$$A_i = \sum_{j=1}^i \prod_{k=j}^i (1 - B_k) X_j \quad (8)$$

Parameter  $p$  is called the average repair efficiency. As particular cases of the BP model, one comes across the two standard models:

- if  $p = 0$ , maintenance is minimal (ABAO model),
- if  $p = 1$ , maintenance is perfect (AGAN model).

### 2.6. Taking into account the effect of PM

There exist several PM types. Systematic planned PM (also called predetermined PM) is carried out in accordance with established intervals of time but without previous condition investigation: from a mathematical point of view, PM times are considered to be deterministic. Condition based PM is PM based on performance and/or parameter monitoring and the subsequent actions: therefore PM times are random.

Let us assume now that CM and predetermined PM actions are carried out on the industrial system. To design a model, denoted  $\mathcal{M}$ , characterizing the behaviour of the system, one must select:

- an initial intensity  $\lambda(t)$  to characterize the intrinsic behaviour of the unused system,
- a model to characterize the effect of CM: AGAN, ABAO, ARA $_{\infty}$ , BP, ...
- a model to characterize the effect of PM: AGAN, ABAO, ARA $_{\infty}$ , BP, ...

For instance, the failure intensity for CM efficiency of the  $ARA_\infty$  type with parameter  $\rho_{CM}$  and PM efficiency of the  $ARA_\infty$  type with parameter  $\rho_{PM}$  is [10]:

$$\lambda_t = \lambda \left( t - C_{K_t^-} + \sum_{j=1}^{K_t^-} (1 - \rho_{PM})^{M_t - M_{C_{j-1}}} (1 - \rho_{CM})^{N_t - N_{C_{j-1}}} W_j \right), t \geq 0 \quad (9)$$

where:

- $\{M_t\}_{t \geq 0}$  is the counting process of PM,
- $\{K_t\}_{t \geq 0}$  is the counting process of both kinds of maintenance (CM and PM) that is to say  $K_t = N_t + M_t, \forall t \geq 0$ ,
- $C_i, i \geq 1$ , are the successive maintenance times (CM and PM),
- $W_i, i \geq 1$ , are the successive inter-maintenances times, that is to say  $W_i = C_i - C_{i-1}$  with  $C_0 = 0$ .

In order to model condition based PM, one must use more complex models, for example in a generalized competing risks framework [11], [12] that will not be addressed in this paper.

### 3. Retrospective assessment of intrinsic system behaviour and maintenance effect

Once model  $\mathcal{M}$  is defined and its failure intensity is written, one can jointly estimate the intrinsic behaviour of the new and non-maintained system and the effect of maintenance actions from the available Operation Feedback (OF). Assuming the system was observed over the time interval  $[t_0 = 0; t_{OBS}]$ , OF data is made up of:

- the  $n$  failure times  $t_i, 1 \leq i \leq n$ , of the system (thus the CM times),
- the  $m$  predetermined PM times  $\tau_j, 1 \leq j \leq m$ , when PM actions were carried out on the system.

$\mathbf{d}_{n,m} = (t_1, \dots, t_n, \tau_1, \dots, \tau_m)$  will denote the OF data observed over  $[0; t_{OBS}]$ . If an initial intensity of the Weibull type is assumed,  $\lambda(t) = \alpha \beta t^{\beta-1}, t \geq 0$ , the intrinsic behaviour of the unused and non-maintained system is characterized by the two unknown parameters  $\alpha$  and  $\beta$ . The efficiencies of CM and/or PM are characterized by the unknown parameters  $\rho_{CM}$  and/or  $\rho_{PM}$  in the case of the  $ARA_\infty$  model and by the unknown parameters  $p_{CM}$  and/or  $p_{PM}$  in the case of the BP model.  $\theta$  will denote the  $k = 3$  and/or 4 dimensional vector of the unknown parameters. These parameters can be estimated by using the classical statistical frequentist framework.

This approach is only based on the OF data to estimate the values, fixed but unknown, of the parameter  $\theta$  in model  $\mathcal{M}$ . The standard frequentist estimation method, and generally the most efficient one, is the maximum likelihood method. It consists in maximizing the parametric likelihood function, or equivalently its logarithm, which depends on the unknown parameters  $\theta$  and can be written [2]:

$$\log(L_{t_{OBS}}(\mathbf{d}_{n,m}; \theta)) = \sum_{i=1}^n \log(\lambda_{t_i}) + \int_0^{t_{OBS}} \lambda_s ds \quad (10)$$

The maximum likelihood estimator  $\hat{\theta}^{ML}$  of unknown parameters vector  $\theta$  is then:

$$\hat{\theta}^{ML} = \underset{\theta}{\operatorname{argmax}} \{ \log(L_{t_{OBS}}(\mathbf{d}_{n,m}; \theta)) \} \quad (11)$$

Calculating  $\hat{\theta}^{\text{ML}}$  is a non-linear optimization problem which requires the use of suitable numerical algorithms. Two deterministic algorithms are classically applied [13]:

- Nelder-Mead, which is based on the simplex method and does not require the calculation of the gradient of the function to be optimized,
- BFGS, which forms a part of the quasi-Newton methods class and iteratively constructs an approximate inverse of the Hessian of the function to be optimized.

The numerical convergence of these algorithms may noticeably depend on the initial parameter values chosen by the user. In order to overcome this difficulty, it is wise to carry out a multi-grid strategy, that is to say to apply these algorithms repeatedly by setting different initial values of the parameters at each iteration. Moreover, there is no optimal algorithm since their efficiency depends on the function to be optimized. That is why it is interesting to apply several optimization methods in parallel: if the same solution is obtained with the different algorithms, it is a good numerical convergence indicator.

Note that this approach can be easily generalized to the analysis of maintenance data of several independent systems by multiplying individual likelihood functions. It is implemented in MARS.

#### **4. Description of the industrial context of the case study and the available OF data**

##### *4.1. Industrial context of the case study*

The case study deals with the economiser of the boiler of an EDF coal-fired power station and more precisely the welds at the stub to header and stub to tube locations. The welds are subjected to thermal fatigue leading to the initiation then propagation of cracks that may generate leaks. These require the immediate shutdown of the boiler, and consequently of the plant, which may be critical for the installation and electric power transmission operators when the energy demand is huge and the power grid is over-stretched. In order to manage the technical and economic risks, a specific maintenance plan is carried out:

- when a leak occurs during plant operation, the incriminated weld is repaired without delay to restart the plant as soon as possible,
- scheduled preventive inspections of the hazard zones of the economiser are carried out periodically and the detected cracks are scoured.

Of course the plant operator raises the two following questions:

- considering the operating historic of the economiser, is it possible to quantify the effect of the maintenance plan and does the latter make it possible to manage the potential intrinsic wear-out of the system (step **(A)**)?
- without modifying the nature and the content of the maintenance tasks (if previously considered efficient), is it possible to optimize the periodicity of the predetermined maintenance actions (step **(B)**)?

The aim of the remainder of the paper is to illustrate in concrete terms how the models and the methods previously described and the MARS software tool can be used and help to answer these questions from the operator. All the figures shown in the following are screenshots of MARS.



Table 1: Available OF data

Number of CS	Maintenance type
25	PM
50	CM
93	CM
109	CM
114	PM
141	CM
163	CM
164	CM
195	CM
225	PM
264	CENS

#### 4.2. Available OF data

The OF data was provided by the plant operator. Unfortunately it is not available since the commission date of the plant: it only covers the operation period 1997-2006. Over this time interval, failure (CM) times and scheduled preventive maintenances (PM) times are at our disposal. Table 1 shows this OF data.

The data is not expressed in calendar time, but in the (cumulative) number of cold starts (CS) over the observation period of the plant: indeed, from a physical point of view, this operation parameter is known to be one of the most influential on the wear-out of the economiser welds. Thus, considering year 1997 as the time of reference:

- $n = 7$  leaks (CM) occurred, the first one after 50 CS and the last one after 195 CS,
- $m = 3$  scheduled preventive maintenance (PM) actions were carried out, with a mean periodicity of 100 CS,
- the ending time of the OF data (right censoring) is  $t_{\text{OBS}} = 264$  CS.

All in all, a sample of 11 OF data is available. If one considers the frequentist statistical estimation framework, this number of data may seem too limited to accurately estimate the models presented in Section 2, some of them depending on 4 unknown parameters. That is why it is necessary to be able to evaluate the estimation uncertainty related to the fact that the study relies on a small data sample. This element will be presented in Section 6.

Later on in this paper, we will assume that the economiser was new in 1997, as OF data has only been available since then. Consequently the presented results will characterize the relative wear-out of the economiser since 1997 rather than its absolute one.

Figure 2 gives first qualitative elements about the management of the intrinsic wear-out of the economiser by the maintenance plan which is carried out. It represents the (cumulative) number of failures depending on the (cumulative) number of CS. The vertical dotted lines symbolize the PM times; the crosses on the horizontal axis mark the CM times; the last cross marks the ending time of observation  $t_{\text{OBS}}$  (right censor). One cannot observe a notable trend in the evolution of the number of failures, neither upward nor downward. In contrast, if the maintenance had not overcome the intrinsic wear-out of the economiser, one would have noticed a convex curve typical of an acceleration of the number of leaks despite the CM and PM actions.

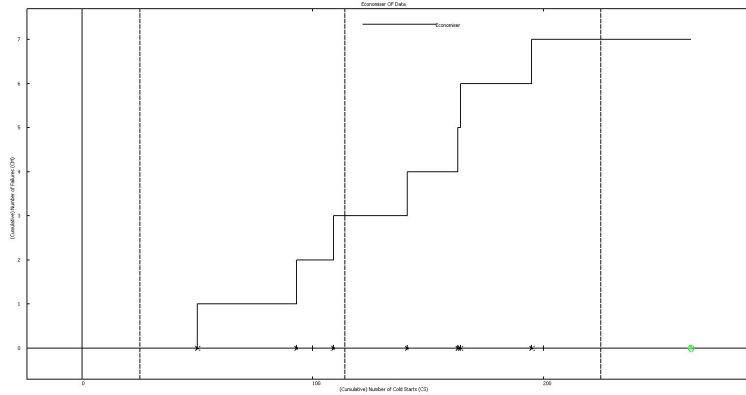

Figure 2: Cumulative number of failures depending on the cumulative number of CS (solid step line)

One can also notice there is only 1 CS between the 5-th and 6-th failures that occurred. This may look atypical compared with the other data and the applied maintenance plan. After checking the accuracy of the data with the plant operator, it turned out that the two failures that occurred in quick succession are not due to poor repair after the 5-th failure: one must set apart the two CM actions and they will be considered separately in the study.

## 5. Models considered for the case study, estimation and predictive reliability indicators

The inherent physical degradation mechanism leading to the leak of the welds is thermal fatigue. Without any maintenance, one can expect that the number of leaks of the economiser will naturally increase with time. Thus the choice of an increasing function for the initial intensity seems relevant to model this likely intrinsic wear-out of the economiser. One should keep in mind that this initial intensity is characterized by two unknown parameters which must be estimated: scale parameter  $\alpha > 0$  and shape parameter  $\beta > 0$ , the latter characterizing the wear-out speed of the system without PM. Under the assumption the economiser intrinsically wears out,  $\beta$  will be higher than 1.

Concerning the maintenance effects, the CM which is carried out consists in repairing the weld that failed without delay in order to restart the plant as soon as possible. Thus CM is very localized and one can think that its effect on the reliability of the economiser is minimal. Conversely the aim of PM is to check all the hazard zones of the economiser and to scour the detected cracks: PM must be close to a perfect maintenance or at least be better than CM.

From these commonsense considerations, validated by the plant operator, we decided, among all the possibilities, to consider and test only the five following virtual age models, classified by increasing order of complexity and modelling refinement:  $\{\text{CM ABAO ; PM AGAN}\}$ ,  $\{\text{CM ARA}_{\infty} ; \text{PM AGAN}\}$ ,  $\{\text{CM ABAO ; PM ARA}_{\infty}\}$ ,  $\{\text{CM ABAO ; PM BP}\}$  and  $\{\text{CM ARA}_{\infty} ; \text{PM ARA}_{\infty}\}$ . One must notice that the  $\{\text{CM ABAO ; PM AGAN}\}$  model is nested within the four other models, since it can be derived from the more complex models by taking particular values for the CM and/or PM efficiency parameters (see Sections 2.4 and 2.5).

Studying several models involves having quantitative indicators allowing to compare them and choose the one among the five in competition which is the most appropriate to available OF data  $\mathbf{d}_{n,m}$ . Several indicators for model selection are available in statistical literature. The ones retained for the study can be classified

into two categories depending on their fundament, which justifies the interest of using them in parallel since they are not based on the same grounds.

### 5.1. Model selection criteria based on information theory

The AIC (for "Akaike Information Criterion"), developed by H. Akaike, is traditionally used [14]. For a given model  $\mathcal{M}(\boldsymbol{\theta})$ , the value of the AIC is:

$$\text{AIC}(\mathcal{M}(\boldsymbol{\theta})) = -2 \log \left( L_{t_{\text{OBS}}} \left( \mathbf{d}_{n,m}; \hat{\boldsymbol{\theta}}^{\text{ML}} \right) \right) + 2k \quad (12)$$

The AIC is grounded in the concept of information entropy, offering a relative measure of the information lost when a given model is used to describe reality. The best model among those considered is the one that minimizes the AIC. This one introduces a penalty term through the number of parameters in the model, which balances the fact that  $\log \left( L_{t_{\text{OBS}}} \left( \mathbf{d}_{n,m}; \hat{\boldsymbol{\theta}}^{\text{ML}} \right) \right)$  is an increasing function of  $k$ , which can be interpreted as a number of degrees of freedom: indeed, the higher the number of parameters in a model is, the more flexible the model is, the better it can fit the data sample. By construction, the best model based on the AIC presents a good compromise between "likelihood" and "modelling complexity".

As the AIC may perform poorly if there are too many parameters in relation to the size of the OF data sample, a variant, called AICc, has been derived to give a greater penalty for extra parameters [14]:

$$\text{AICc}(\mathcal{M}(\boldsymbol{\theta})) = \text{AIC}(\mathcal{M}(\boldsymbol{\theta})) + \frac{2k(k+1)}{n-k-1} = -2 \log \left( L_{t_{\text{OBS}}} \left( \mathbf{d}_{n,m}; \hat{\boldsymbol{\theta}}^{\text{ML}} \right) \right) + \frac{2kn}{n-k-1} \quad (13)$$

Even if the sample is made up of  $n+m$  data, AICc is computed by only considering the  $n$  failures (CM), that is to say the number of data really observed, since in our case the PM actions are deterministic and can be considered to be censored data [15]. The use of the AICc is strongly recommended when  $n$  is small with respect to  $k$ .

The BIC (for "Bayesian Information Criterion"), developed by G.E. Schwarz, is another common criterion based on information theory. It can be seen as a generalization of the AIC in a Bayesian framework [16]. For a given model  $\mathcal{M}(\boldsymbol{\theta})$ , the value of the BIC is:

$$\text{BIC}(\mathcal{M}(\boldsymbol{\theta})) = -2 \log \left( L_{t_{\text{OBS}}} \left( \mathbf{d}_{n,m}; \hat{\boldsymbol{\theta}}^{\text{ML}} \right) \right) + 2k \log(n) \quad (14)$$

The BIC penalizes the number of parameters more strongly than the AIC does. The best model among those considered is the one that minimizes the BIC.

### 5.2. Model selection criteria based on prediction errors

Two other criteria can be calculated. They are derived from empirical distribution function statistics usually employed to test the goodness-of-fit of a random variable from a sample data to a hypothesized distribution [17]:

$$D_{\text{sup}}(\mathcal{M}(\boldsymbol{\theta})) = \sup_{t \in \{t_1; t_2; \dots; t_n\}} \{ |N_t - \mathbb{E}_{\hat{\boldsymbol{\theta}}^{\text{ML}}}(N_t)| \} \quad (15)$$

and

$$D^2(\mathcal{M}(\boldsymbol{\theta})) = \sum_{t \in \{t_1; t_2; \dots; t_n\}} (N_t - \mathbb{E}_{\hat{\boldsymbol{\theta}}^{\text{ML}}}(N_t))^2 \quad (16)$$

Table 2: Estimations for the five considered models and model selection criteria

Initial intensity of the Weibull type	Considered models				
	{CM ABAO ; PM AGAN}	{CM ARA <sub>∞</sub> ; PM AGAN}	{CM ABAO ; PM ARA <sub>∞</sub> }	{CM ABAO ; PM BP}	{CM ARA <sub>∞</sub> ; PM ARA <sub>∞</sub> }
Number $k$ of parameters in the model to be estimated	2	3	3	3	4
Number $n$ of CM	7				
Parameters	Maximum likelihood estimations				
Scale parameter $\alpha$	1.02e-3	1.16e-5	1.02e-3	1.02e-3	1.16e-5
Shape parameter $\beta$	1.74	3.05	1.74	1.74	3.05
CM efficiency parameter $\rho_{CM}$ Or $p_{CM}$	-	0.56	-	-	0.56
PM efficiency parameter $\rho_{PM}$ Or $p_{PM}$	-	-	1	1	1
Maximum value of the log-likelihood function	-31.17	<b>-29.48</b>	-31.17	-31.17	<b>-29.48</b>
AIC	66.34	<b>64.96</b>	68.34	68.34	66.96
AICc	<b>69.34</b>	72.96	76.34	76.34	86.96
BIC	66.23	<b>64.8</b>	68.18	68.18	66.74
$D_{sup}$	2.31	<b>2.14</b>	2.31	2.31	<b>2.14</b>
$D^2$	12.96	<b>9.87</b>	12.96	12.96	<b>9.87</b>

where  $N_t, t \geq 0$  is the cumulative number of failures observed up to time  $t$  and  $\mathbb{E}_{\hat{\theta}^{ML}}(N_t)$  is the expected cumulative number of failures observed up to time  $t$  under estimated model  $\mathcal{M}(\hat{\theta}^{ML})$ , which can be evaluated through Monte-Carlo simulations when it has no explicit analytical expression. These two criteria are based on a supremum or quadratic difference, which can be interpreted as a prediction error, between the observed trajectory of the counting process of CM and the expected trajectory of the counting process associated with  $\mathcal{M}(\hat{\theta}^{ML})$ . The best model among those considered is the one that minimizes  $D_{sup}$  or  $D^2$ .

### 5.3. Model estimation and predictive reliability indicators

Table 2 shows, for the different considered models, the estimations obtained with the OF data using the maximum likelihood method. The two algorithms which were carried out, Nelder-Mead and BFGS, produce strictly identical values for all the estimates: one can believe the optimization methods properly converged and the obtained estimations are accurate from a numerical point of view. The five previous model selection criteria are also given for each estimated model.

Whatever the considered model, the estimated shape parameter is strictly higher than 1, which confirms that the economiser is subjected to an intrinsic wear-out. When it is estimated, the parameter related to CM efficiency equals 0.56, which means that CM almost halves the virtual age of the economiser. PM is estimated to be perfect, using either a BP or an ARA<sub>∞</sub> model and whatever CM efficiency is, which explains the strong similarities between the estimated parameters values in the five considered models.

From the model selection criteria, the "best" model among those tested seems to be the {CM ARA<sub>∞</sub> ; PM AGAN} model, since it minimizes all the indicators whatever their basis, except for the AICc which is minimal for the simplest {CM ABAO ; PM AGAN} model. That is why the {CM ARA<sub>∞</sub> ; PM AGAN} model will be considered to be the most "appropriate" one: it will be the reference later on in the case study and will be denoted  $\hat{\mathcal{M}}^{OPT}$ .

Here one can notice the interest of having imperfect maintenance models such as the  $ARA_{\infty}$  one, which allow to take into account maintenance effects between the two extreme cases ABAO and AGAN and thus enable us to model in a more accurate and realistic way the impact of the maintenance actions on the reliability of the industrial system. This easily stands out in Figure 3, which plots the failure intensity function of  $\hat{\mathcal{M}}^{OPT}$  over the observation period. After a CM action (crosses on the horizontal axis), the failure intensity decreases to a value comprised between 0 and the one it had just before failure, while after a PM action (vertical dotted lines) the failure intensity returns to 0 as if the economiser was a new one.

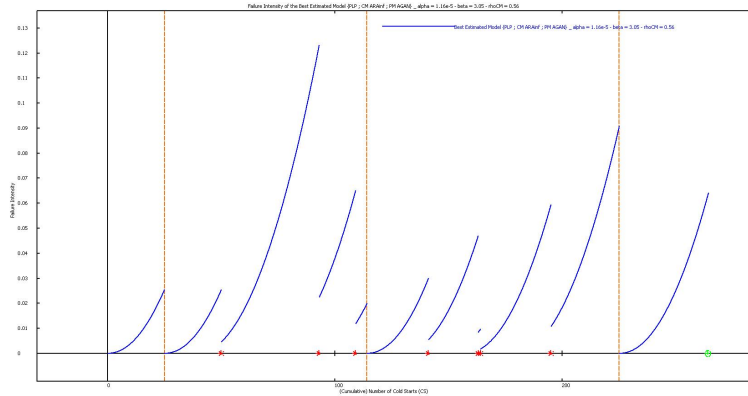

Figure 3: Failure intensity function of the "best" model  $\hat{\mathcal{M}}^{OPT}$  depending on the cumulative number of CS (solid line)

Figure 4 overlays, over the observation period of the OF data, the (cumulative) number of observed failures (solid step line) and the mean (cumulative) numbers of failures assessed from the "best" model  $\hat{\mathcal{M}}^{OPT}$  (continuous dashed line) and the {CM ABAO ; PM AGAN} model (continuous dotted line). It allows to visualize how well the two estimated models fit the data set.

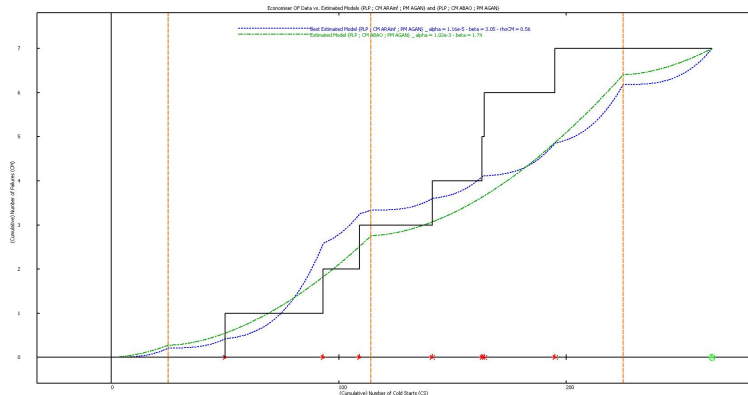

Figure 4: Comparison between the (cumulative) number of observed failures (step solid line) and the mean (cumulative) numbers of failures assessed from  $\hat{\mathcal{M}}^{OPT}$  (continuous dashed line) and the {CM ABAO ; PM AGAN} model (continuous dotted line)

From  $\hat{\mathcal{M}}^{OPT}$  and the past of the CM-PM process, MARS enables us to assess predictive reliability indicators, especially useful for decision making support. For instance, MARS provides the expected value and the

standard deviation of the time to the next failure, for a given PM strategy in the future. With the current PM periodicity of 100 CS, the estimated mean is 10.4 CS and the estimated standard deviation is 7.9 CS. These values seem to be low, but in fact the system has been renewed for the last time in  $\tau_m = 225$  CS. Since no maintenance occurred between 225 and  $t_{\text{OBS}} = 264$  CS, the system age at  $t_{\text{OBS}}$  is 39 CS. Then it is likely that a failure will occur not long after  $t_{\text{OBS}}$ .

## 6. Uncertainty estimation evaluation

In Table 2, when the PM efficiency parameter is estimated, it is equal to 1, that is to say the supremum of its domain of definition. This leads us to believe that if the model could allow it, the estimation would be higher than 1, which would mean that PM leaves the economiser in a state "better than new".

This observation makes us suppose that the obtained estimates lack robustness from a statistical point of view. Moreover, values 3.05 for the shape parameter and 0.56 for the CM efficiency parameter are higher than the ones that could have been expected before the estimation and one may have the impression that these estimates over-evaluate the "true" values of the parameters. Two reasons may explain these observations.

The first one is wrongly considering that the economiser was new at the reference time from which the OF data is available. Taking into account this left censoring is nowadays possible for some virtual age models [18], but unfortunately not for all of them.

The second possible cause is that the data sample is too small and not informative enough to correctly estimate the models with at least three parameters.

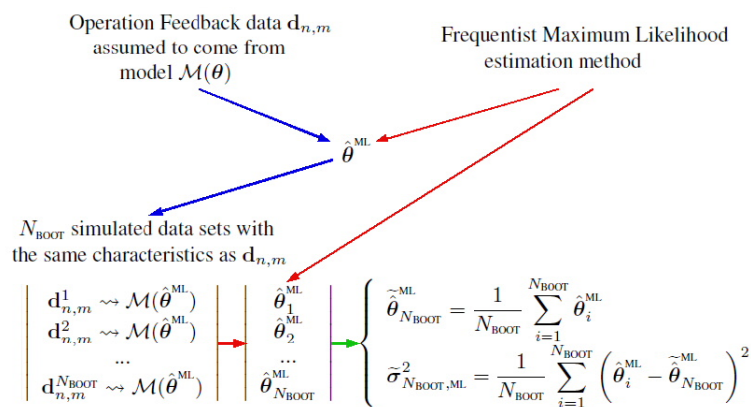

Figure 5: Principle of the parametric bootstrap procedure to evaluate the model estimation uncertainty

That is why it is advisable when possible to quantify the estimation uncertainty inherent in the manipulation of a small data set, in order to assess the robustness of the obtained results. MARS enables us to evaluate this estimation uncertainty by performing an intensive simulation procedure called parametric bootstrap [19], whose principle is presented in Figure 5. The idea of this resampling process is to evaluate how the estimations of the parameters could have been impacted if one had had another data set different from the OF data sample but drawn from the same (estimated) underlying model, thus with identical (deterministic) PM times, number of CM and maintenance effects. One applied the parametric bootstrap to the {CM ARA $_{\infty}$  ; PM AGAN} model which seems to fit the OF data best.

Table 3 shows the results of the parametric bootstrap procedure, that is to say the mean and the standard de-

Table 3: Results from the parametric bootstrap applied to {CM ARA<sub>∞</sub> ; PM AGAN} model

Weibull type for the initial intensity / BFGS algorithm	{CM ARA <sub>∞</sub> ; PM AGAN} model	
Parameters	Bootstrap means	Bootstrap standard deviations
Scale parameter $\alpha$	8.3e-5	4.4e-4
Shape parameter $\beta$	3.5	0.65
CM efficiency parameter $\rho_{CM}$	0.61	0.19

viation of the  $N_{BOOT} = 10^4$  estimations of the 4 parameters obtained by performing the maximum likelihood method on the  $N_{BOOT}$  simulated data sets.

One can notice that the bootstrap mean of the estimation of the CM efficiency parameter is similar to the estimation obtained exclusively with the observed OF data sample. On the contrary, the bootstrap means of the shape and scale parameters are noticeably higher than the values used to sample the  $N_{BOOT}$  bootstrap data sets and which have been obtained only with the OF data, which means that the values of  $\alpha$  and  $\beta$  presented in Table 2 are probably over-estimated. The associated bootstrap standard deviations are not negligible either.

The reason that can be propounded to explain these results is that the estimations obtained with the observed OF data sample might be biased and significantly depend on the data set used to obtain them: the statistical accuracy of these estimations might thus be questionable. Therefore, for practical purposes, the intrinsic reliability might be in reality higher than initially envisaged in Section 5.3, which would concretely mean that the maintenance plan globally manages the wear-out process of the economiser more efficiently. This point can be simply illustrated by the expected value of the time to the next failure, which equals 0.3 CS with the bootstrap estimations of the parameters against 10.4 CS with the parameters of  $\hat{\mathcal{M}}^{OPT}$ .

We notice here one of the limits of the frequentist estimation approach, which is only based on the observed data sample which in our case may be too small to be informative enough and provide robust estimations of the parameters.

A promising alternative solution would be to use the statistical Bayesian framework [20]. This approach makes it possible to balance a lack of OF data by merging two sources of information: the objective information from the available OF data and the subjective knowledge which is often expendable about the behaviour of the system or the efficiency of the maintenance actions carried out. In practice this subjective knowledge can be directly inferred from experts' elicitation [21]. The Bayesian estimation approach has been successfully applied in the context of imperfect maintenance models in [22], [23], [24] and [25] and it is a major direction of future improvement for the current study.

## 7. Prospective optimization of the periodicity of the PM actions

Now that the retrospective estimation of the effective maintenance plan has been carried out (step (A)) and one has concluded that the latter overcomes on the whole the intrinsic wear-out of the economiser, one can wonder if it is possible to optimize in a prospective way (step (B)) the periodicity of the predetermined (thus deterministic) preventive maintenance actions without modifying the nature and the content of the maintenance tasks, thus without changing the CM and PM efficiencies which have just been estimated. To that end, it is necessary to define a criterion that will allow to decide on the interest of modifying the PM periodicity. For this case study, we decided to choose an economic indicator, as in [26] and [27].

Let us denote:

- $t_{\text{REF}} \leq t_{\text{OBS}}$  the reference time for the PM periodicity optimization study. Generally, as the new maintenance plan will be established in the continuity of the current one,  $t_{\text{REF}}$  will be chosen equal to the last observed PM time, that is to say  $t_{\text{REF}} = \tau_m$ ,
- $t_{\text{OBJ}} > t_{\text{OBS}}$  the operation time set as an objective by the plant operator and posterior to the ending time of the OF data  $t_{\text{OBS}}$ .

The predictive total maintenance cost (non discounted) over the analysis time interval  $[t_{\text{OBS}}; t_{\text{OBJ}}]$  has the following mathematical expression:

$$C_{\text{TOT}}(t_{\text{OBS}}, t_{\text{REF}}, t_{\text{OBJ}}, \omega_{\text{PM}}) = (N_{t_{\text{OBJ}}} - N_{t_{\text{OBS}}}) \times C_{\text{CM}} + (M_{t_{\text{OBJ}}} - M_{t_{\text{OBS}}}) \times C_{\text{PM}} \quad (17)$$

where:

- $N_{t_{\text{OBJ}}} - N_{t_{\text{OBS}}}$  is the (random) number of CM actions carried out over the time interval  $[t_{\text{OBS}}; t_{\text{OBJ}}]$ ,
- $C_{\text{CM}}$  is the unit cost of a failure (assumed deterministic and non discounted),
- $C_{\text{PM}}$  is the unit cost of a PM action (assumed deterministic and non discounted),
- $M_{t_{\text{OBJ}}} - M_{t_{\text{OBS}}}$  is the number of PM actions carried out over the time interval  $[t_{\text{OBS}}; t_{\text{OBJ}}]$ . It is a deterministic number that is function of the predetermined PM periodicity  $\omega_{\text{PM}} > 0$ .

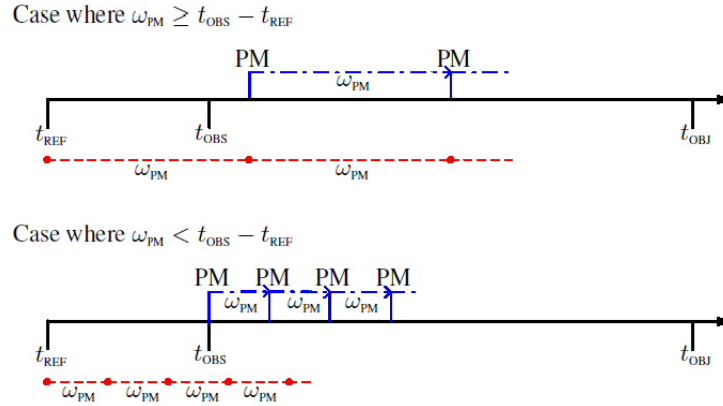

Figure 6: Proposed preventive maintenance plan depending on the value of the PM periodicity  $\omega_{\text{PM}}$

$M_{t_{\text{OBJ}}} - M_{t_{\text{OBS}}}$  is not simply equal to  $\left\lfloor \frac{t_{\text{OBJ}} - t_{\text{OBS}}}{\omega_{\text{PM}}} \right\rfloor$ , where  $\lfloor \cdot \rfloor$  stands for the floor function, since PM planning starts from  $t_{\text{REF}}$ , not  $t_{\text{OBS}}$ . Indeed as presented in Figure 6:

- if  $\omega_{\text{PM}} \geq t_{\text{OBS}} - t_{\text{REF}}$ , the preventive maintenance policy plans no PM between  $t_{\text{REF}}$  and  $t_{\text{OBS}}$ . The first PM action is planned beyond  $t_{\text{OBS}}$  and all the predetermined PM can be carried out. Thus the number of PM actions over the time interval  $[t_{\text{OBS}}; t_{\text{OBJ}}]$  is equal to  $M_{t_{\text{OBJ}}} - M_{t_{\text{OBS}}} = \left\lfloor \frac{t_{\text{OBJ}} - t_{\text{REF}}}{\omega_{\text{PM}}} \right\rfloor$ .



- on the contrary if  $\omega_{\text{PM}} < t_{\text{OBS}} - t_{\text{REF}}$ , the preventive maintenance strategy plans PM actions between  $t_{\text{REF}}$  and  $t_{\text{OBS}}$ . But no PM have been observed over this time interval (unless  $t_{\text{REF}}$  is actually higher than or equal to the time of the last PM). To compensate for these planned PM that have not been carried out, it seems logical to carry out one as soon as possible, that is to say in  $t_{\text{OBS}}$ . Therefore in this specific case, we suggest the preventive maintenance strategy that consists first in carrying out a PM action in  $t_{\text{OBS}}$  and then from this date in resuming the predetermined PM with the periodicity  $\omega_{\text{PM}}$ . Consequently the number of PM actions over the time interval  $[t_{\text{OBS}}; t_{\text{OBJ}}]$  is equal to  $M_{t_{\text{OBJ}}} - M_{t_{\text{OBS}}} = 1 + \left\lfloor \frac{t_{\text{OBJ}} - t_{\text{OBS}}}{\omega_{\text{PM}}} \right\rfloor$ .

Finally we have:

$$M_{t_{\text{OBJ}}} - M_{t_{\text{OBS}}} = \begin{cases} \left\lfloor \frac{t_{\text{OBJ}} - t_{\text{REF}}}{\omega_{\text{PM}}} \right\rfloor & \text{if } \omega_{\text{PM}} \geq t_{\text{OBS}} - t_{\text{REF}} \\ 1 + \left\lfloor \frac{t_{\text{OBJ}} - t_{\text{OBS}}}{\omega_{\text{PM}}} \right\rfloor & \text{if } \omega_{\text{PM}} < t_{\text{OBS}} - t_{\text{REF}} \end{cases} \quad (18)$$

Indicator  $C_{\text{TOT}}$  is made of two factors: a random component related to the predictive number of failures over the time interval  $[t_{\text{OBS}}; t_{\text{OBJ}}]$  and a deterministic component associated with the predictive number of PM set by the periodicity of the new PM plan. Since  $C_{\text{TOT}}$  is a random variable, one will focus on its expected value and the "optimal" PM periodicity  $\omega_{\text{PM}}^{\text{OPT}}$  will be the one minimizing the expected value of  $C_{\text{TOT}}(t_{\text{OBS}}, t_{\text{REF}}, t_{\text{OBJ}}, \omega_{\text{PM}})$ . When a model is fully specified, the MARS software tool can simulate through a Monte-Carlo procedure possible predictive trajectories of the CM and PM processes, thus allowing to obtain an estimation of the expected value of  $C_{\text{TOT}}$  and determine the optimal periodicity of the PM actions. For this study, we considered the "best" model  $\mathcal{M}^{\text{OPT}}$ .  $N = 10^4$  trajectories were drawn. The input data, fictitious but realistic, are the following:

- $t_{\text{REF}} = \tau_m = 225$  CS,
- $t_{\text{OBS}} = 264$  CS,
- $t_{\text{OBJ}} = 524$  CS  $\approx 2 \times t_{\text{OBS}}$ : we decided to make predictions over an analysis time interval no longer than the observation period of the OF data,
- $C_{\text{CM}} = 120$  keuros,
- $C_{\text{PM}} = 70$  keuros,
- $5 \leq \omega_{\text{PM}} \leq 200$  CS by step of 0.1 CS.

Because of the immediate shutdown of the plant due to one failure (leak), the unit CM cost is noticeably higher than the PM one.

The mean predictive total maintenance cost function presented in Figure 7 shows a globally convex trend, which ensures the existence of the sought-after optimal periodicity  $\omega_{\text{PM}}^{\text{OPT}}$ . The observed bend can be explained as follows.

If the PM periodicity is too low, one might carry out PM actions too often compared with the intrinsic wear-out process of the economiser. As the PM actions are efficient, CM actions are avoided, but PM is carried out unnecessarily: one obtains a very low CM cost, but which is largely compensated by the over-dimensioned PM cost as expressed in Equation 19:

$$C_{\text{TOT}}(t_{\text{OBS}}, t_{\text{REF}}, t_{\text{OBJ}}, \omega_{\text{PM}}) \stackrel{\omega_{\text{PM}} \rightarrow 0}{\sim} \left\lfloor \frac{t_{\text{OBJ}} - t_{\text{OBS}}}{\omega_{\text{PM}}} \right\rfloor \times C_{\text{PM}} \quad (19)$$

Conversely if the PM periodicity is too high, the intrinsic wear-out of the economiser leads to an explosion of failures and high associated costs, as the CM actions are not very efficient. Thus the predictive total maintenance cost is driven by the CM cost as expressed in Equation 20:

$$C_{\text{TOT}}(t_{\text{OBS}}, t_{\text{REF}}, t_{\text{OBJ}}, \omega_{\text{PM}}) \stackrel{\omega_{\text{PM}} \rightarrow +\infty}{\sim} (N_{t_{\text{OBJ}}} - N_{t_{\text{OBS}}}) \times C_{\text{CM}} \quad (20)$$

Figure 7: Mean predictive total maintenance cost depending on the PM periodicity

From Figure 7, the optimal periodicity  $\omega_{\text{PM}}^{\text{OPT}}$  is 32.8 CS with model  $\hat{\mathcal{M}}^{\text{OPT}}$ , with a mean predictive total maintenance cost of about 1016 keuros.

One notices that if there is a doubt, it is preferable to increase the PM periodicity (since the mean predictive total maintenance cost slowly increases beyond  $\omega_{\text{PM}}^{\text{OPT}}$ ) rather than reducing it (since the mean predictive total maintenance cost suddenly increases while moving from  $\omega_{\text{PM}}^{\text{OPT}}$  to lower periodicities).

One also observes a "wavelet phenomenon" on the mean predictive total maintenance cost function. It is due to the discontinuities implied by the floor function in the calculation of the number of PM carried out over the time interval  $[t_{\text{OBS}}; t_{\text{OBJ}}]$  (see Equation 18). These discontinuities happen each:

- $\frac{t_{\text{OBJ}} - t_{\text{REF}}}{i}$  for every  $i$  such that  $0 < i \leq \frac{t_{\text{OBJ}} - t_{\text{REF}}}{t_{\text{OBS}} - t_{\text{REF}}}$ ,
- $\frac{t_{\text{OBJ}} - t_{\text{OBS}}}{i-1}$  for every  $i$  such that  $\frac{t_{\text{OBJ}} - t_{\text{REF}}}{t_{\text{OBS}} - t_{\text{REF}}} < i$ .

The height of the wavelets is constant and equal to  $C_{\text{PM}}$ . Thus the optimal PM periodicity strongly depends on  $t_{\text{OBJ}}$  and small variations of the objective time can arbitrarily change the value of  $\omega_{\text{PM}}^{\text{OPT}}$ . In order to avoid this phenomenon, one must tend  $t_{\text{OBJ}}$  to infinity and then consider the mean predictive total maintenance cost per unit of time, as it is usually done in literature [26]:

$$\bar{C}_{\text{TOT}}(t_{\text{OBS}}, t_{\text{REF}}, t_{\text{OBJ}}, \omega_{\text{PM}}) = \frac{C_{\text{TOT}}(t_{\text{OBS}}, t_{\text{REF}}, t_{\text{OBJ}}, \omega_{\text{PM}})}{t_{\text{OBJ}} - t_{\text{OBS}}} \quad (21)$$

In this case, the height of the wavelets equals  $\frac{C_{\text{PM}}}{t_{\text{OBJ}} - t_{\text{OBS}}}$  which tends to 0 when  $t_{\text{OBJ}}$  tends to infinity.

Figure 8 shows the impact of the choice of  $t_{\text{OBJ}}$  on the shape of the curve of the mean predictive total maintenance cost per unit of time and on  $\omega_{\text{PM}}^{\text{OPT}}$ . Considering model  $\hat{\mathcal{M}}^{\text{OPT}}$ , several curves of the mean predictive total maintenance cost per unit of time are represented for several values of  $t_{\text{OBJ}}$ . It is clear that the higher  $t_{\text{OBJ}}$  is, the smoother the curve is and the less sensitive to the variations of  $t_{\text{OBJ}}$  the optimal PM periodicity is. Thus  $\omega_{\text{PM}}^{\text{OPT}}$  will be obtained by tending  $t_{\text{OBJ}}$  to infinity. In practice, we will take a value of  $t_{\text{OBJ}}$  high enough: in our case study, we chose  $t_{\text{OBJ}} = 5240$  CS and we obtained  $\omega_{\text{PM}} = 30$  CS.

Figure 8: Impact of the objective time on the mean predictive total maintenance cost per unit of time

Finally we varied the values of the model parameters from  $\hat{\mathcal{M}}^{\text{OPT}}$  in order to analyze how the model estimation uncertainty impacts the optimization of the PM periodicity. So as to eliminate the "wavelet phenomenon" previously described, we considered a value of  $t_{\text{OBJ}}$  high enough, equal to 5240 CS. In order to set rational variations for the values of the model parameters, we used the estimations obtained from the parametric bootstrap procedure (see Table 3). For parameters  $\beta$  and  $\rho_{\text{CM}}$ , we considered a variation from the bootstrap mean within the range plus or minus the bootstrap standard deviation. For scale parameter  $\alpha$ , one systematically considered the value that maximized the log-likelihood function for the considered values of

Figure 9: Impact of the variations of the model parameters on the mean predictive total maintenance cost per unit of time

Table 4: Optimal PM periodicity depending on the values of the model parameters

Scale parameter $\alpha$	Shape parameter $\beta$	CM efficiency parameter $\rho_{CM}$	Optimal PM periodicity $\omega_{PM}^{OPT}$	Minimal mean maintenance cost per unit of time $\bar{C}_{TOT}^{OPT}$
1.16e-5	3.05	0.56	30	3.65
3.16e-7	4.15	0.8	26	3.69
1.11e-7	4.15	0.42	33	2.89
3.53e-5	2.85	0.8	30	4.21
1.84e-5	2.85	0.42	33	3.43

$\beta$  and  $\rho_{CM}$ . The mean predictive total maintenance costs per unit of time are plotted in Figure 9 and the associated optimal PM periodicities are shown in Table 4.

One can notice that even if the mean maintenance cost functions are fairly different depending on the values of the model parameters, the optimal PM periodicity is little influenced, with values close to 30 CS. Thus even if the estimations of the model parameters seemed to be little accurate from a statistical point of view, the calculation of  $\omega_{PM}^{OPT}$  looks robust.

The mean periodicity of the current maintenance plan is about 100 CS, which corresponds to a mean predictive total maintenance cost of about 1300 keuros for model  $\hat{\mathcal{M}}^{OPT}$ . Thus the study demonstrates that from a technical and economic point of view, it is beneficial to reduce the periodicity of the predetermined PM actions by 70 CS to expect reducing the mean predictive maintenance costs by about 305 keuros, that is a saving of about 25%. Sensitivity analyses to the input data (in particular the CM and PM costs) and estimation of the uncertainty related to  $\bar{C}_{TOT}$  are considered further developments that could strengthen the current results and be useful for decision making support.

## 8. Conclusions and prospects

The presented case study allowed to illustrate how the imperfect maintenance models can be carried out and can help the plant operator to define efficient maintenance plans. It also showed the interest of using a software tool such as MARS, which, by offering an integrated approach of the whole process of maintenance assessment and optimization, easily enables us:

- on the one hand, to estimate the intrinsic wear-out of the system and to assess maintenance effect on system reliability, in order to check retrospectively if the effective maintenance plan satisfies the objectives set initially (step (A)),
- on the other hand, to carry out technical and economic studies to optimize the periodicity of the predetermined preventive maintenance actions (step (B)).

In order to better represent real-life conditions and the complexity of the maintenance plans carried out on the systems in the plants, several methodological extensions are possible. One can consider the use of bathtub shaped models for the initial intensity or generalized competing risks models for imperfect maintenance, which would allow us to deal with condition based PM. This case study also pointed out the need to take into account left censored data, as the OF data is not always available since the commission date of the system.

We also mentioned the potential benefit of the Bayesian approach, when the OF data sample is too small to ensure the accuracy of the estimations obtained with the classical frequentist approach. For instance, performing Markov Chain Monte-Carlo [28], in order to sample the whole posterior distribution and provide credibility intervals for the parameter estimations, would be a conceivable prospect. However, this would first require making progress in the construction of prior distributions adapted to virtual age models and the development of indicators dealing with the consistency, the agreement and the weighting [29] between subjective knowledge from expertise and objective information from OF data.

Model validation and selection as well as introduction of covariates (for instance manufacturing conditions or environmental and operation stress factors) are also two major directions of future research with a view to improving the refinement and the predictive accuracy of the models developed so far.

**Note:** MARS is available upon request from the archive download site: [https://www-ljk.imag.fr/Mars/release\\_en.html](https://www-ljk.imag.fr/Mars/release_en.html)

- [1] Corset F, Despréaux S, Doyen L, and Gaudoin O. MARS: a software tool for maintenance assessment of repairable systems. In *Proceedings of the 6-th international conference on mathematical methods in reliability, MMR 2009*, Moscow, Russia, 2009.
- [2] Cook RJ and Lawless JF. *The statistical analysis of recurrent events*. New York: Springer, 2007.
- [3] Dijoux Y. A virtual age model based on a bathtub shaped initial intensity. *Reliability Engineering and System Safety*, 94(5):982–989, 2009.
- [4] Pham H and Wang H. Imperfect maintenance. *European Journal of Operational Research*, 94(3):425–428, 1996.
- [5] Kijima M. Some results for repairable systems with general repair. *Journal of Applied Probability*, 26(9):89–102, 1989.
- [6] Doyen L and Gaudoin O. Classes of imperfect repair models based on reduction of failure intensity or virtual age. *Reliability Engineering and System Safety*, 84(1):45–56, 2004.
- [7] Brown JF and Proschan F. Imperfect repair. *Journal of Applied Probability*, 20:51–859, 1983.
- [8] Lindqvist BH, Elvebakk G, and Heggland K. The trend-renewal process for statistical analysis of repairable systems. *Technometrics*, 45(1):31–44, 2003.
- [9] Brown JF, Mahoney J, and Sivazlian B. Hysteresis repair in discounted replacement problems. *IIE Transactions*, 15(2):156–165, 1983.
- [10] Doyen L and Gaudoin O. Modelling and assessment of ageing and efficiency of corrective and planned preventive maintenance actions. Submitted, 2011.
- [11] Dijoux Y, Doyen L, and Gaudoin O. Conditionally independent generalized competing risks for maintenance analysis. In Bedford T, Quigley J, Walls L, Alkali B, Daneshkhah A, and Hardman G, editors, *Advances in mathematical modeling for reliability*, pages 88–95. Amsterdam: IOS Press, 2008.
- [12] Doyen L and Gaudoin O. Imperfect maintenance in a generalized competing risks framework. *Journal of Applied Probability*, 43(3):825–839, 2006.

- [13] Bartholomew-Biggs M. *Nonlinear optimization with engineering applications*. New York: Springer, 2008.
- [14] Burnham KP and Anderson DR. *Model selection and multimodel inference: a practical information-theoretic approach - second edition*. New York: Springer, 2002.
- [15] Volinsky CT and Raftery AE. Bayesian information criterion for censored survival models. *Biometrics*, 56(1):256–262, 2000.
- [16] Burnham KP and Anderson DR. Multimodel inference: understanding AIC and BIC in model selection. *Sociological Methods Research*, 33(2):261–304, 2004.
- [17] D’Agostino RB and Stephens MA. *Goodness-of-fit techniques*. New York: Marcel Dekker, 1986.
- [18] Doyen L. A generalized brown-proschan model for preventive and corrective maintenance. In *Proceedings of the international symposium on business and industrial statistics, ISBIS 2010*, Portoroz, Slovenia, 2010.
- [19] Efron B and Tibshirani RJ. *An introduction to the bootstrap*. London: Chapman Hall/CRC, 1993.
- [20] Robert CP. *The bayesian choice: from decision-theoretic foundations to computational implementation - second edition*. New York: Springer, 2007.
- [21] O’Hagan A, Buck CE, Daneshkhah A, Eiser JR, Garthwaite PH, Jenkinson DJ, Oakley JE, and Rakow T. *Uncertain judgements - Eliciting experts’ probabilities*. New York: Wiley, 2006.
- [22] Corset F, Doyen L, and Gaudoin O. Bayesian analysis of the  $ARA_{\infty}$  imperfect maintenance model. In *Proceedings of the 7-th international conference on mathematical methods in reliability, MMR 2011*, Beijing, China, 2011.
- [23] Lim JH, Lu KL, and Park DH. Bayesian imperfect repair model. *Communication in Statistics Theory and Methods*, 27(4):965–984, 1998.
- [24] Pan R and Rigdon S. Bayes inference for general repairable systems. *Journal of Quality Technology*, 41(1):82–94, 2009.
- [25] Pulcini G. On the overhaul effect for repairable mechanical units: a Bayes approach. *Reliability Engineering and System Safety*, 70(1):85–94, 2000.
- [26] Fan H, Hu C, Chen M, and Zhou D. Cooperative predictive maintenance of repairable systems with dependent failure modes and resource constraint. *IEEE Transactions on Reliability*, 60(1):144–157, 2011.
- [27] Taghipour S and Banjevic D. Periodic inspection optimization models for a repairable system subject to hidden failures. *IEEE Transactions on Reliability*, 60(1):275–285, 2001.
- [28] Meyn S and Tweedie RL. *Markov chains and stochastic stability - second edition*. London: Cambridge University Press, 2009.
- [29] Bousquet N. Diagnostics of prior-data agreement in applied bayesian analysis. *Journal of Applied Statistics*, 35:1011–1029, 2008.