



**HAL**  
open science

# On the Existence of Approximated Equilibria and Sharing-Rule Equilibria in Discontinuous Games

Philippe Bich, Rida Laraki

► **To cite this version:**

Philippe Bich, Rida Laraki. On the Existence of Approximated Equilibria and Sharing-Rule Equilibria in Discontinuous Games. 2013. hal-00846143

**HAL Id: hal-00846143**

**<https://hal.science/hal-00846143v1>**

Preprint submitted on 18 Jul 2013

**HAL** is a multi-disciplinary open access archive for the deposit and dissemination of scientific research documents, whether they are published or not. The documents may come from teaching and research institutions in France or abroad, or from public or private research centers.

L'archive ouverte pluridisciplinaire **HAL**, est destinée au dépôt et à la diffusion de documents scientifiques de niveau recherche, publiés ou non, émanant des établissements d'enseignement et de recherche français ou étrangers, des laboratoires publics ou privés.

# On the Existence of Approximated Equilibria and Sharing-Rule Equilibria in Discontinuous Games\*

Philippe Bich<sup>†</sup> and Rida Laraki<sup>‡</sup>

July 13, 2013

## Abstract

New relaxations of the Nash equilibrium concept are shown to exist in any strategic game with discontinuous payoff functions. The new concepts are used (1) to show the equivalence between Reny's *better-reply security* condition [28] and Simon-Zame's *endogenous tie-breaking rule* equilibrium concept [32], (2) to obtain conditions for the existence of *approximated equilibria* in a class of discontinuous games that naturally extends Reny's better-reply secure games, and (3) to show the existence of approximated equilibria in a large family of two-player games that contains all standard models of auctions.

**JEL classification:** C02, C62, C72.

**Keywords:** Discontinuous games, better-reply security, sharing-rule equilibrium, approximated equilibrium, strategic approximation, auctions, diagonal games.

## 1 Introduction

Many economic interactions can be formulated as games with *discontinuous* payoff functions. Examples include price and spatial competition, auctions, bargaining problems, preemption games, wars of attrition, general equilibrium models, etc.

To study the existence of a Nash equilibrium in these games, standard results such as the Nash-Glicksberg's theorem [16, 25, 26] fail because they require continuous utility functions. As a result, two kinds of issues were explored in the literature.

The first issue is to identify some regularity conditions on payoffs, which combined with a limited form of quasiconcavity of utility functions, guarantee the existence of a Nash equilibrium. The first conditions of existence are given by the seminal papers of Dasgupta and Maskin [12, 13]. The significant

---

\*We thank Panayotis Mertikopoulos and Christina Pawlowitsch for their useful comments. We thank many participants of the following seminars or conferences for their valuable comments: Conference on Economic Theory, June 2012 (Cowles, Yale), International Conference on Game Theory, July 2012 (Stony Brook), SAET conference, July 2012 (Brisbane), Workshop on Dynamic Game Theory, December 2012 (Valparaiso), Roy-Adres Seminar, September 2011 (Paris), CSEF Seminar, November 2011 (Napoli). This research was supported by grant ANR-10-BLAN 0112 (Laraki).

<sup>†</sup>Paris School of Economics, Centre d'Economie de la Sorbonne UMR 8174, Université Paris I Panthéon/ Sorbonne, 106/112 Boulevard de l'Hôpital 75647 Paris Cedex 13. E-mail: bich@univ-paris1.fr

<sup>‡</sup>CNRS, Economics Department, Ecole Polytechnique, France. Part/time associated of the Équipe Combinatoire et Optimisation, IMJ, CNRS UMR 7586, Université Pierre et Marie Curie. E-mail: rida.laraki@polytechnique.edu

breakthrough, extending the previous results, is achieved by Reny [28] throughout the *better-reply security* condition.

Quoting Reny, “A game is better-reply secure if for every nonequilibrium strategy  $x^*$  and every payoff vector limit  $u^*$  resulting from strategies approaching  $x^*$ , some player  $i$  has a strategy yielding a payoff strictly above  $u_i^*$  even if the others deviate slightly from  $x^*$ ”. In particular, many examples above are better-reply secure and consequently admit a Nash equilibrium. Reny’s paper induces a large and still extremely active research agenda. For instance, Barelli and Soza [3, 5] and McLennan et al. [24] propose an extension to non-transitive preferences and non-quasiconcave games, Reny [29, 30] introduces a refinement of better-reply security, Carmona [9] gives an extension of Dasgupta and Maskin’s results, which are unrelated to Reny’s approach. More recently, Barelli et al. [4] apply Reny’s tools to prove the existence of the value (and so existence for an  $\varepsilon$ -Nash equilibrium for every  $\varepsilon > 0$ ) in a large class of zero-sum games including the Colonel Blotto game.

The second issue is to propose an alternative solution concept for games without a Nash equilibrium. Simon and Zame [32] argue that “payoffs should be viewed as only partially determined, and that whenever the economic nature of the problem leads to indeterminacies, the sharing rule should be determined endogenously.” Actually, in most applications, discontinuities are located on a low-dimensional subspace of strategy profiles (firms or players choosing the same price, location, bid, acting time, etc.). In some of these games, the *exogenously* given tie-breaking rule leads to no pure Nash equilibrium (e.g. asymmetric Bertrand duopoly, Hotelling location game) or no mixed Nash equilibrium (e.g. 3-player timing games [22], auctions with correlated types or values [15, 18]). However, the existence of a Nash equilibrium is restored if the tie-breaking rule is chosen *endogenously* [21, 23, 32]. For instance, in an asymmetric Bertrand duopoly, a pure Nash equilibrium exists if ties are broken in favor of the lower-cost firm. Simon and Zame give a significant answer by proving, under mild topological conditions on the strategy spaces, the existence of a *solution* (i.e. a Nash equilibrium in *mixed strategies* after an eventual modification of payoff functions at discontinuity points).

Another alternative solution for games without a Nash equilibrium is the notion of *approximated equilibrium*. An approximated equilibrium is a limit strategy profile  $x^*$  and a limit payoff vector  $u^*$  of  $\varepsilon$ -Nash equilibria  $x^\varepsilon$  with associated payoff vector  $u(x^\varepsilon)$ , as  $\varepsilon$  goes to 0. It was shown to exist in many games such as two-player stochastic and timing games [22, 34, 35] and more recently for the Colonel Blotto game [4]. Surprisingly, there is but only one general result in the spirit of Nash’s theorem which provides the existence of approximated equilibria, due to Prokopovych [27]. While theoretically interesting, it requires assumptions on payoff functions that are not applicable in many economic problems (such as auctions).

The main objective of our paper is (1) to establish a connection between better-reply security, endogenous sharing rule and approximated equilibrium, in pure and mixed strategies and (2) to extend Reny, Simon and Zame’s ideas (usually used to study existence of a Nash equilibrium) to study existence of an approximated equilibrium.

A first result is the “equivalence” between Reny and Simon-Zame approaches in pure strategies. This answers to a question of Jackson and Swinkel [19], who ask if “these approaches [Reny and Simon-Zame] turn out to be related”.<sup>1</sup> This equivalence requires the extension of Simon and Zame’s solution to pure

---

<sup>1</sup>De Castro [11] proposes an answer to the question of Jackson et al. [17] in a restricted class of games.

strategies, since the Simon and Zame solution concept is only defined and proved to exist in mixed strategies. This leads us to the concept of *sharing-rule equilibrium*, which induces a Nash equilibrium whenever the game is better-reply secure.

The existence of a sharing-rule equilibrium in any quasiconcave game without any topological assumptions on the payoff functions is a second result of our paper. This answers another open question in Jackson et al. [17], who, after extending Simon and Zame’s solution to game with incomplete information, remark that their “*results concern only the existence of solutions in mixed strategies* and that they “*have little to say about the existence of solutions in pure strategies*”. Technically, the proof of existence of a sharing-rule equilibrium is a direct consequence of Reny’s [28] existence result.

A third contribution is an equivalence result similar to the previous one, in mixed strategies. This requires the introduction of the *finite deviation equilibrium* concept. We link it to the useful idea of strategic approximation recently studied by Reny [30].

The last important contribution concerns approximated equilibria. Actually, the existence of a sharing-rule equilibrium in any quasiconcave compact game leads naturally to a new class of games in which an approximated equilibrium always exists. These are games satisfying the following weaker form of better-reply security: for every non-approximated equilibrium  $(x^*, u^*)$ , some player  $i$  has a strategy yielding a payoff strictly above  $u_i^*$  even if the others deviate slightly from  $x^*$ .

Our paper is organized as follows. In Section 2, we outline the main approaches of the literature (Reny [28], Simon-Zame [32] and Prokopovych [27]). In Section 3, we unify Reny and Simon-Zame in pure strategy games by introducing Reny and sharing-rule equilibrium concepts. Section 4 is devoted to the existence of approximated equilibria in pure strategies. In Section 5, we consider the mixed strategy case. We introduce the finite deviation equilibrium concept and use it (1) to unify Reny and Simon-Zame, (2) to show the existence of a strategic approximation in a large class of games, and (3) to provide conditions for the existence of approximated equilibria in mixed strategies. In Section 6, we refine Reny’s equilibrium (in pure strategies) in three different directions. One of them concerns the non-quasiconcave case, which is illustrated with Hotelling’s location game. Another is related to the recent extension of Reny by Barelli and Soza [5]. The last extension proves a general existence result which refines and implies many recent extensions of Reny’s better-reply security condition [3, 5, 9, 10, 28, 29]. Importantly, the proof of this extension is almost standard since based on a classical fixed theorem combined with a new selection lemma. The last section (appendix) provides the most technical proofs.

To illustrate the results, a general class of two-player games (diagonal games) is introduced in Section 4 (in pure strategies and complete information) and Section 5 (in mixed strategies with incomplete information). It includes almost all known models of competitions, in particular Bertrand, location, bargaining, Cournot with capacities, auctions and timing games, among others. As a byproduct, we show the existence of an approximated mixed equilibrium in any two-player auction with incomplete information. Recall that such games may have no Nash equilibrium, as shown in [15, 18]. For instance, in a first price auction with complete information, the rational behavior is for the player with the highest evaluation to bid slightly above the second highest evaluation, which provides an approximated equilibrium. This paper proves that the existence of an approximated equilibrium is indeed guaranteed in a large class of two-player auction games.

## 2 Three Approaches to Discontinuous Games

A game in strategic form  $G = ((X_i)_{i \in N}, (u_i)_{i \in N})$  is given by a finite set  $N$  of players, and for each player  $i$ , a set  $X_i$  of pure strategies and a payoff function  $u_i : X = \prod_{i \in N} X_i \rightarrow \mathbb{R}$ . This paper assumes  $G$  to be *compact*: for every  $i \in N$ ,  $X_i$  is a compact subset of a topological vector space and  $u_i$  is bounded.<sup>2</sup>

**Definition:**  $x \in X$  is a *Nash equilibrium* if for every  $i \in N$ ,  $V_i(x_{-i}) := \sup_{d_i \in X_i} u_i(d_i, x_{-i}) \leq u_i(x)$ ,

where  $x_{-i} = (x_j)_{j \neq i}$ . A game  $G$  is *quasiconcave* if for every  $i$ ,  $X_i$  is convex and for every  $x_{-i} \in X_{-i} := \prod_{j \neq i} X_j$ , the mapping  $u_i(\cdot, x_{-i})$  is quasiconcave. The game is *continuous* if for every  $i$ ,  $u_i$  is continuous<sup>3</sup>.

**Nash-Glicksberg's theorem (in pure strategies):** any continuous, quasiconcave and compact game  $G$  admits a Nash equilibrium.

The rest of the section presents three different extensions of this result. Our paper links them into one general idea.

### 2.1 Better-Reply Security

In many discontinuous games, a Nash equilibrium exists (Bertrand price competition, auctions, location games, concession games, wars of attrition among many). Reny's theorem [28] provides an explanation for this.

Formally, let  $\Gamma = \{(x, u(x)) : x \in X\}$  denote the graph of  $G$  and  $\bar{\Gamma}$  be the closure of  $\Gamma$ . Since  $G$  is compact,  $\bar{\Gamma}$  is compact as well. Define the “secure payoff level” of player  $i$  when he plays  $d_i$  and when the other players play  $x_{-i}$  as follows:

$$\underline{u}_i(d_i, x_{-i}) = \liminf_{x'_{-i} \rightarrow x_{-i}} u_i(d_i, x'_{-i}).^4$$

This is the payoff that player  $i$  can almost guarantee by playing  $d_i$ , if the other players are allowed to deviate slightly from  $x_{-i}$ .

**Definition:**  $G$  is *better-reply secure* if whenever  $(x, v) \in \bar{\Gamma}$  and  $x$  is not a Nash equilibrium, some player  $i \in N$  can secure<sup>5</sup> a payoff strictly above  $v_i$ , i.e. there exists  $d_i \in X_i$  such that  $\underline{u}_i(d_i, x_{-i}) > v_i$ .

It is easy to verify that any continuous game is better-reply secure.

**Reny's theorem [28]:** any better-reply secure, quasiconcave and compact game admits a Nash equilibrium.

<sup>2</sup>Some results require the strategy sets to be metric and/or Hausdorff.

<sup>3</sup> $X$  is endowed with the product topology.

<sup>4</sup>The notation  $\liminf_{x'_{-i} \rightarrow x_{-i}}$  could be misleading since the strategy spaces are not necessarily metric: convergence should be understood in the sense of nets. A topological definition of  $\liminf$  is the following:  $\liminf_{x'_{-i} \rightarrow x_{-i}} u_i(d_i, x'_{-i}) = \sup_{V \in \mathcal{V}(x_{-i})} \inf_{x'_{-i} \in V} u_i(d_i, x'_{-i})$ , where  $\mathcal{V}(x_{-i})$  denotes the set of neighborhoods of  $x_{-i}$ .

<sup>5</sup>Player  $i$  can secure a payoff above  $\alpha \in \mathbb{R}$  if there exists  $d_i \in X_i$  and a neighborhood  $V_{-i}$  of  $x_{-i}$  such that for every  $x'_{-i} \in V_{-i}$ ,  $u_i(d_i, x'_{-i}) \geq \alpha$ .

In his paper, Reny gives two useful sufficient conditions under which a game is better-reply secure: payoff security and reciprocal upper semicontinuity.

**Definition:** (i)  $G$  is *reciprocally upper semicontinuous* if, whenever  $(x, v) \in \bar{\Gamma}$  and  $u(x) \leq v$ , then  $u(x) = v$ . (ii)  $G$  is *payoff secure*<sup>6</sup> at  $x_{-i} \in X_{-i}$  if  $V_i(x_{-i}) = \underline{V}_i(x_{-i})$ , where  $\underline{V}_i(x_{-i}) := \sup_{d_i \in X_i} \underline{u}_i(d_i, x_{-i})$ .

## 2.2 Approximated Equilibrium

A natural relaxation of Nash equilibrium is the following.

**Definition:**  $(x, v) \in \bar{\Gamma}$  is an *approximated equilibrium* if there exists a sequence<sup>7</sup>  $(x^n)_{n \in \mathbb{N}}$  of  $X$  such that:

- (i) for every  $n \in \mathbb{N}^*$ ,  $x^n$  is a  $\frac{1}{n}$ -equilibrium, that is: for every player  $i \in N$  and every deviation  $d_i \in X_i$ ,  $u_i(d_i, x_{-i}^n) \leq u_i(x^n) + \frac{1}{n}$ .
- (ii) the sequence  $(x^n, u(x^n))$  converges to  $(x, v)$ .

Several classes of games do not have a Nash equilibrium but do admit an approximated equilibrium (two-player undiscounted stochastic games [34, 35], two-player timing games [22], among others). However, in the literature, few topological conditions for the existence of an approximated equilibrium exist. This subsection describes such a result. One of the main objectives of our paper is to extend this theorem using Reny's better-reply security idea and apply it to a large class of two-player games.

**Definition:** a game  $G$  has the marginal continuity property if  $V_i$  is continuous for every  $i$ .

**Prokopovych's theorem [27]:** any payoff secure, quasiconcave and compact game that has the marginal continuity property admits an approximated equilibrium.

A continuous game is payoff secure and has the marginal continuity property. Moreover, continuity insures that approximated and Nash equilibria coincide. Consequently, Prokopovych's theorem is an extension of Nash-Glicksberg's theorem. First-price auction (with complete information) and asymmetric Bertrand's competition do not have a Nash equilibrium but have an approximated equilibrium (see example 3). They are payoff secure and have the marginal continuity property. However, the following known location game [32] is not payoff secure, but does have an approximated equilibrium. Our extension of Prokopovych's theorem applies to this example (see Section 3).

**Example 1.** The length interval  $[0, 4]$  represents an interstate highway. The strategy set of player 1 (a psychologist from California) is  $X = [0, 3]$  (representing the Californian highway stretch). The strategy set of player 2 (a psychologist from Oregon) is  $Y = [3, 4]$  (the Oregon part of the highway). The payoff function of player 1 is  $u_1(x, y) = \frac{x+y}{2}$  if  $x < y$  and  $u_1(3, 3) = 2$ . The payoff function of player 2 is  $u_2(x, y) = 4 - u_1(x, y)$ . The strategy profile  $x_n = (3 - \frac{1}{n}, 3)$ , corresponding to the vector payoff  $v_n = (3 - \frac{1}{2n}, 1 + \frac{1}{2n})$ , is a  $\frac{1}{2n}$ -equilibrium. Consequently,  $(x = (3, 3), v = (3, 1))$  is an approximated equilibrium. However, the game is not payoff secure for player 2 at  $x = (3, 3)$ .

<sup>6</sup>Actually, Reny defines a game  $G$  to be payoff secure if for every  $x \in X$ , for every  $\varepsilon > 0$ , every player  $i \in N$  can secure a payoff above  $u_i(x) - \varepsilon$ . we can check that this implies  $V_i(x_{-i}) = \underline{V}_i(x_{-i})$  for every  $x \in X$ , the converse being not true.

<sup>7</sup>Again, the definition is stated in terms of sequences, while we should use convergence in the sense of nets.

### 2.3 Endogenous Tie-Breaking Rule

The California location game above is introduced by Simon and Zame [32] to illustrate their equilibrium notion. They propose to change slightly the game by exhibiting an alternative tie-breaking rule at discontinuity points so that the auxiliary game admits a Nash equilibrium.

**Example 2. (California location game, continued)** The California location game, defined above, is constant-sum, discontinuous and has no Nash equilibrium. Define a new payoff function  $q$  as follows:  $q(x) = u(x)$  for every  $x \neq (3, 3)$  and  $q(3, 3) = (3, 1)$ . The pure strategy profile  $(3, 3)$  is a Nash equilibrium of the game defined by  $q$ . The new sharing rule at  $x = (3, 3)$  has a simple interpretation: it corresponds to giving each psychologist his/her natural market share.

Simon and Zame do not assume the game to be quasiconcave, but allow the use of *mixed strategies*. Formally,  $G$  is *metric* if strategy sets are Hausdorff and metrizable and payoff functions are measurable. Denote by  $M_i = \Delta(X_i)$  the set of Borel probability measures on  $X_i$  (usually called the set of mixed strategies of player  $i$ ). This is a compact Hausdorff metrizable set under the weak\* topology. Let  $M = \prod_i M_i$ . A *mixed Nash equilibrium* of  $G$  is a (pure) Nash equilibrium of its mixed extension  $G' = ((M_i)_{i \in N}, (u_i)_{i \in N})$ , where payoff functions are extended multi-linearly to  $M$ .

**Definition:** A couple  $(\sigma, q)$  is a *solution* (call it a sharing-rule mixed equilibrium) of  $G$  if  $\sigma \in M$  is a mixed equilibrium of the auxiliary game  $\tilde{G} = ((X_i)_{i \in N}, (q_i)_{i \in N})$ , where the auxiliary payoff functions  $q = (q_i)_{i \in N}$  must satisfy:<sup>8</sup>

$$(SR): \forall y \in X, q(y) \in \text{co}\bar{\Gamma}_y,$$

where,  $\bar{\Gamma}_x = \{v \in \mathbb{R}^N : (x, v) \in \bar{\Gamma}\}$  is the  $x$ -section of  $\bar{\Gamma}$ .

Condition (SR) has two implications that justify the term sharing rule: if  $u$  is continuous at  $x$ ,  $q(x) = u(x)$ ; if  $\sum_{i \in N} u_i(x)$  is continuous then  $\sum_{i \in N} q_i(x) = \sum_{i \in N} u_i(x)$ .

**Simon and Zame's theorem [32]:** any metric and compact game admits a sharing-rule mixed equilibrium.

Again, this is an extension of the Nash-Glicksberg's theorem in *mixed strategies*: when the game is continuous, the auxiliary and the original games coincide. In that case, the theorem states that:

**Nash-Glicksberg's theorem (in mixed):** any continuous, metric and compact game admits a mixed Nash equilibrium.

Jackson et al. [17] extend Simon and Zame's theorem to games with incomplete information. In their paper, they interpret a tie-breaking rule as a proxy for the outcome of an unmodeled second stage game. As example, they recall the analysis of first-price auctions with incomplete information for a single indivisible object. Maskin and Riley [23] add to the sealed-bid stage a second stage where bidders with the highest bid in the first stage play a Vickrey auction. In the private value setting, their dominant strategy

<sup>8</sup>Where *co* stands for the convex hull.

is to bid their true values. Consequently, the second stage induces a tie-breaking rule where the bidder with the highest value wins the object. More generally, a tie-breaking rule may be implemented by asking players to send a cheap message (their private values in auctions), in addition to their strategies (bids). The messages will be used only to break ties (as in the second stage of Maskin and Riley's mechanism).

### 3 Sharing-Rule Equilibrium in Pure Strategies

As explained in the introduction, the relation between Simon-Zame and Reny's existence results is an important open question. The aim of this section is to give a formal equivalence between these two results in pure strategies, the mixed-strategy case being treated in Section 5. The link with approximated equilibrium and in particular with Prokopovych's theorem is presented in the next section.

**Example 3.** In a Bertrand duopoly, two firms  $i = 1, 2$  choose prices  $p_i \in [0, a]$  ( $a > 0$ ). Assume a linear demand  $a - \min(p_1, p_2)$  and marginal costs  $c_1 < c_2 < \frac{a+c_1}{2}$ . The game has no pure Nash equilibrium if we assume that the firm charging the lowest price supplies the entire market. Nevertheless, the game is quasiconcave and compact. This game has a solution à la Simon-Zame, with a strategy profile  $(c_2, c_2)$  and with payoff function  $q(c_2, c_2) = ((a - c_2)(c_2 - c_1), 0)$ , while  $q(x) = u(x)$  elsewhere. This seems to be the intuitive solution of the game and it may be related to another standard tool to circumvent the non-existence of a Nash equilibrium: just assume a smallest monetary unit  $\delta > 0$ . Then, the strategy profile  $(c_2 - \delta, c_2)$  is a Nash equilibrium of this discretized game. The associated payoff vector is  $((c_2 - \delta - c_1)(a - c_2 + \delta), 0)$ . As  $\delta$  goes to zero, we obtain the Simon-Zame's solution.

Several remarks are of interest. Both examples (California location and Bertrand's duopoly) yield a solution (à la Simon and Zame) in *pure strategies*, yet Simon-Zame equilibrium notion is defined in *mixed strategies*. Second, the solution happens to be an approximated equilibrium in both cases (in example 2, consider the sequence of  $\frac{1}{2^n}$ -Nash equilibria  $(3 - \frac{1}{n}, 3)$ , and in example 3, the sequence  $(c_2 - \frac{1}{n}, c_2)$ ). Third, both games are not better-reply secure, because they are quasiconcave, compact, but have no Nash equilibrium.

The next definition extends Simon-Zame's solution to games in pure strategies.

**Definition 1**  $(x, v) \in \bar{\Gamma}$  is a sharing-rule equilibrium if  $x$  is a (pure) Nash equilibrium of an auxiliary game  $\tilde{G} = ((X_i)_{i \in N}, (q_i)_{i \in N})$ , where:

- (i)  $v = q(x)$  is the associated vector payoff.
- (ii) For every  $y \in X$ ,  $q(y) \in \bar{\Gamma}_y$ .
- (iii) For every  $i \in N$  and every  $d_i \in X_i$ ,  $q_i(d_i, x_{-i}) \geq \underline{u}_i(d_i, x_{-i})$ .

In other words, a sharing-rule equilibrium is a pure strategy profile  $x$  and a payoff vector  $v$  such that  $x$  is a classical Nash equilibrium of an auxiliary game  $\tilde{G}$  and  $v$  is the associated payoff vector at  $x$ . Without conditions on  $\tilde{G}$ , any strategy profile could be made a Nash equilibrium of some auxiliary game. To reduce the number of solutions, the new game must be as close as possible to the original game. Condition (ii) says that  $q(y)$  is a limit point of some  $u(y_n)$  as  $y_n$  goes to  $y$ . Consequently, only payoffs at discontinuity points of  $u$  are modified. Hence it is similar to condition (SR) in Simon and Zame, but no convex hull is required. Condition (iii) asks the payoff function of a player in the auxiliary game to



remain above the security payoff level in the original game. This is not required by Simon and Zame. The following example shows its importance.

**Example 4.** Consider a one-player game who maximizes over  $[0, 1]$  the following discontinuous payoff function:  $u(x) = 0$  if  $x < 1$ , and  $u(1) = 1$ . The rational solution is clearly the profile  $x = 1$  yielding the highest possible payoff. But the constant payoff function  $q = 0$  satisfies Condition (ii) above. So, any mixed strategy profile  $\sigma$  is a solution à la Simon-Zame. Condition (iii) implies that the unique possible auxiliary payoff function is  $q = u$ , and the only equilibrium strategy of the auxiliary game is  $x = 1$ .

More generally, in a one-player game, the upper semicontinuous regularization of  $u$ , defined by  $u^{u.s.c.}(x) = \limsup_{x' \rightarrow x} u(x')$ , satisfies (ii) and (iii). Thus, if  $x$  maximizes  $u^{u.s.c.}$ , then  $(x, u^{u.s.c.}(x))$  is a sharing-rule equilibrium. For two players or more, the payoff profile  $q = (u_i^{u.s.c.})_{i \in N}$  may not satisfy (ii) or even (SR). Examples are easy to construct.

To link sharing-rule equilibrium with Reny's better-reply security and prove its existence, we introduce the following new equilibrium concept.

**Definition 2**  $(x, v) \in \bar{\Gamma}$  is a Reny equilibrium if

$$\forall i \in N, \underline{V}_i(x_{-i}) := \sup_{d_i \in X_i} \underline{u}_i(d_i, x_{-i}) \leq v_i.$$

**Theorem 1.** Any quasiconcave and compact game  $G$  admits a Reny equilibrium.

Existence is a straightforward consequence of Reny's [28] theorem. Indeed, assume, by contradiction, that there is no Reny equilibrium. This implies that the game is better-reply secure. Consequently, from Reny [28], there exists a Nash equilibrium, which is obviously a Reny equilibrium: a contradiction.

**Theorem 2.** Any quasiconcave and compact game  $G$  admits a sharing-rule equilibrium.

Let us prove Theorem 2. From Theorem 1, there exists a Reny equilibrium  $(x, v) \in \bar{\Gamma}$ . Then, we can build the sharing-rule equilibrium as follows. For every  $i \in N$  and  $d_i \in X_i$ , denote by  $\underline{\mathcal{S}}(d_i, x_{-i})$  the space of sequences  $(x_{-i}^n)_{n \in \mathbb{N}}$  of  $X_{-i}$  converging to  $x_{-i}$  such that  $\lim_{n \rightarrow +\infty} u_i(d_i, x_{-i}^n) = \underline{u}_i(d_i, x_{-i})$ . Then, define  $q : X \rightarrow \mathbb{R}^N$  by

$$q(y) = \begin{cases} v & \text{if } y = x, \\ \text{any limit point of } (u(d_i, x_{-i}^n))_{n \in \mathbb{N}} & \text{if } y = (d_i, x_{-i}) \text{ for some } i \in N, d_i \neq x_i, (x_{-i}^n)_{n \in \mathbb{N}} \in \underline{\mathcal{S}}(d_i, x_{-i}), \\ q(y) = u(y) & \text{otherwise.} \end{cases}$$

Now, let us prove that  $x$  is a sharing-rule equilibrium profile associated to  $q$ . Since  $(x, v) \in \bar{\Gamma}$ , and by definition of  $q$ , condition (ii) of Definition 1 is satisfied at  $x$ . Obviously, it is satisfied at every  $y$  different from  $x$  for at least two components, and also at every  $(d_i, x_{-i})$  with  $d_i \neq x_i$ , from the definition of  $q(d_i, x_{-i})$  in this case. To prove condition (iii) of Definition 1, let  $i \in N$  and  $d_i \in X_i$ . If  $d_i = x_i$  then  $q_i(d_i, x_{-i}) = q_i(x) = v_i \geq \underline{u}_i(x)$  because  $(x, v)$  is a Reny equilibrium. If  $d_i \neq x_i$  then  $q_i(d_i, x_{-i}) = \underline{u}_i(d_i, x_{-i})$  so that condition (iii) holds. The proof is complete.

The following proposition links Reny, Nash, approximated and sharing-rule equilibria.

**Proposition 3**

- i) *Reny and sharing-rule equilibria coincide.*
- ii) *If  $x \in X$  is a Nash equilibrium,  $(x, u(x))$  is a Reny equilibrium.*
- iii) *If  $(x, v) \in \bar{\Gamma}$  is an approximated equilibrium,  $(x, v)$  is a Reny equilibrium.*
- iv) *A game is better-reply secure if and only if Nash and Reny equilibria coincide.*

**Proof.** Part i) is a consequence of the last proof and the definition of a sharing-rule equilibrium. For ii), if  $x \in X$  is a Nash equilibrium, then  $u_i(x) \geq u_i(d_i, x_{-i}) \geq \underline{u}_i(d_i, x_{-i})$  for every player  $i \in N$  and every deviation  $d_i \in X_i$ . For iii), if  $(x, v) \in \bar{\Gamma}$  is an approximated equilibrium, let  $(x^n)_{n \in \mathbb{N}}$  be a sequence of  $\frac{1}{n}$ -equilibria such that  $(x^n, u(x^n))$  converges to  $(x, v)$ . By definition,  $u_i(d_i, x_{-i}^n) \leq u_i(x^n) + \frac{1}{n}$  for every  $n \in \mathbb{N}$ , for every player  $i \in N$  and every deviation  $d_i \in X_i$ . Passing to the infimum limit when  $n$  tends to infinity, we obtain  $\underline{u}_i(d_i, x_{-i}) \leq v_i$ . To finish, iv) is a straightforward consequence of the definitions of Reny equilibrium and better-reply security.

Thus, the Reny equilibrium has an appealing interpretation as a sharing rule and constitutes a necessary condition for a profile to constitute a Nash equilibrium. Moreover, the notion of a Reny equilibrium may be used to simplify some proofs in the literature. To illustrate this, let us prove that a payoff secure and reciprocally upper semicontinuous game is better-reply secure: if  $(x, v)$  is a Reny equilibrium, then  $\sup_{d_i \in X_i} \underline{u}_i(d_i, x_{-i}) \leq v_i$  for every player  $i \in N$ . Since the game is payoff secure, we obtain  $\sup_{d_i \in X_i} u_i(d_i, x_{-i}) \leq v_i$ . Taking  $d = x$ , we deduce that  $u(x) \leq v$ . Since the game is reciprocally upper semicontinuous,  $v = u(x)$ . Consequently,  $x$  is a Nash equilibrium.

The next section uses Reny equilibria (or equivalently sharing-rule equilibria) to establish conditions for existence of approximated equilibria in quasiconcave compact games and explains why in Bertrand duopoly (and many similar games), sharing-rule equilibria and approximated equilibria coincide.

## 4 Approximately Better-Reply Secure Games

The previous section shows that a game is better-reply secure if and only if Nash and Reny equilibria coincide. Following this idea, introduce the following class of games.

**Definition 4**  *$G$  is approximately better-reply secure if Reny and approximated equilibria coincide. Equivalently, if whenever  $(x, v) \in \bar{\Gamma}$  is not an approximated equilibrium, then there exists a player  $i \in N$  and  $d_i \in X_i$  such that  $\underline{u}_i(d_i, x_{-i}) > v_i$ .*

This is a natural relaxation of Reny’s definition. Existence of a Reny equilibrium implies:

**Theorem 3.** *Any approximately better-reply secure, quasiconcave and compact game admits an approximated equilibrium.*

The following example of Dasgupta and Maskin [13] illustrates the result.

**Example 5.** There are two players,  $X_1 = X_2 = [0, 1]$  and the payoff functions are defined as follows:

$$u_i(x_1, x_2) = \begin{cases} 0 & \text{if } x_1 = x_2 = 1, \\ x_i & \text{otherwise.} \end{cases}$$

No pure Nash equilibrium exists. However, the game is approximately better-reply secure:  $(x = (1, 1), v = (1, 1))$  is the unique Reny and approximated equilibrium. It is, in our opinion, the intuitive solution of the game.

Let us give two applications. The first encompasses Prokopovych's theorem and California location game, the second implies the existence of an approximated equilibrium in a general class of two-player games.

**Proposition 5** *Let  $G$  be a quasiconcave and compact game  $G$  where:*

- (i) *The function  $\underline{V}_i(x_{-i})$  is continuous.*
- (ii) *If  $x \in X$  is not a Nash equilibrium, some player  $i \in N$  can secure a payoff strictly above  $u_i(x)$ .*
- (iii)  *$G$  is payoff secure except on a finite set of profiles.*

*Then  $G$  is approximately better-reply secure.*

**Proof.** Let  $(x, v)$  be a Reny equilibrium. Remark that from (ii), if  $(x, u(x))$  is a Reny equilibrium, then  $x$  is a Nash equilibrium. Thus, if  $v = u(x)$ , from (ii),  $x$  is a Nash equilibrium and so is an approximated equilibrium. Suppose  $v \neq u(x)$ . Consequently, there exists a sequence of distinct points  $(x^n, u(x^n))$  converging to  $(x, v)$ . From (iii),  $\sup_{d_i \in X_i} \underline{u}_i(d_i, x_{-i}^n) = \sup_{d_i \in X_i} u_i(d_i, x_{-i}^n)$  for  $n$  large enough, and from (i), the limit is  $\sup_{d_i \in X_i} \underline{u}_i(d_i, x_{-i})$ . Consequently,  $(x, v)$  is an approximated equilibrium.

This implies Prokopovych's theorem: if  $\underline{V}_i(x_{-i}) = \underline{V}_i(x_{-i})$  is continuous, conditions i), ii) and iii) are satisfied. The California location game does not satisfy Prokopovych's assumptions (it is payoff secure except at  $(3, 3)$ ), but satisfies i), ii) and iii).

Consider now the following class of two-player games on the unit square.

**Example 6.** Let  $f_i, g_i$  and  $h_i$  be three mappings from  $X = [0, 1] \times [0, 1]$  to  $\mathbb{R}$ ,  $i = 1, 2$ . The payoff of player  $i$  is

$$u_i(x_i, x_{-i}) = \begin{cases} f_i(x_i, x_{-i}) & \text{if } x_{-i} > x_i, \\ g_i(x_i, x_{-i}) & \text{if } x_{-i} < x_i, \\ h_i(x_i, x_{-i}) & \text{if } x_{-i} = x_i. \end{cases}$$

Call such a model a *diagonal game*, denoted  $G = ((f_i, g_i, h_i)_{i=1,2})$ . It includes most two-player models of competition with complete information such as: auctions, Bertrand games, spatial games, Cournot games with capacities and timing games. The following proposition (proved in Appendix 8.1) provides the existence of an approximated equilibrium for a large class of diagonal games.

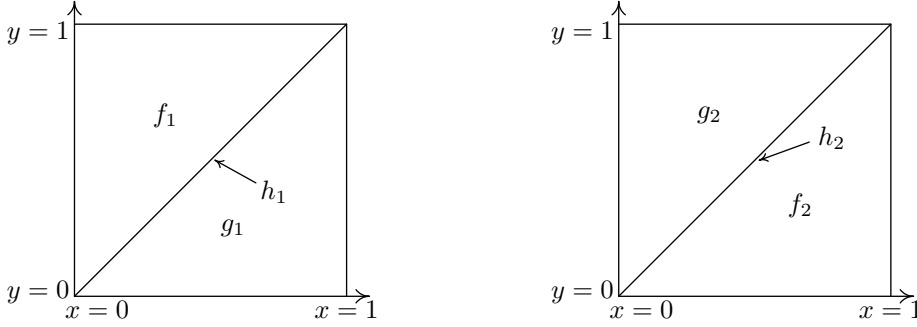

Figure 1: Representation of  $u_1(x, y)$  and  $u_2(x, y)$  in Example 6

**Proposition 6** Any quasiconcave diagonal game satisfying (i) and (ii) below is approximately better-reply secure, where:

(i)  $f_i$  and  $g_i$  are continuous,  $i = 1, 2$ .

(ii)  $h_i(x_i, x_i) \in \text{co}\{f_i(x_i, x_i), g_i(x_i, x_i)\}$  for every  $(x_i, x_i) \in [0, 1] \times [0, 1]$ .

Suppose for instance that  $g_i(\cdot, x_{-i})$  is non-increasing and  $f_i(\cdot, x_{-i})$  is non-decreasing on  $[0, 1]$  (for every  $x_{-i} \in X_{-i}$  and  $i = 1, 2$ ): under Condition (ii) above, the diagonal game is quasiconcave, and Proposition 6 can be applied whenever  $f$  and  $g$  are continuous. This is to be compared with Example 3.1 in Reny [28], where under similar conditions, a Nash equilibrium is proved to exist in the smaller class of timing games.

The following examples prove that without condition (i) or (ii) in Proposition 6, an approximated equilibrium may fail to exist. When (ii) is not satisfied but  $h$  is supposed to be continuous, we can prove that an approximated equilibrium still exists, using a refinement of Reny equilibrium (see Section 6.1). When the game fails to be quasiconcave, existence of an approximated equilibrium must be studied in mixed strategies (see next section).

**Example 7.** Consider the two-player game where the strategy spaces are  $X = Y = [0, 1]$ , and the payoff functions  $u_i$  are defined below and illustrated in Figure 1:

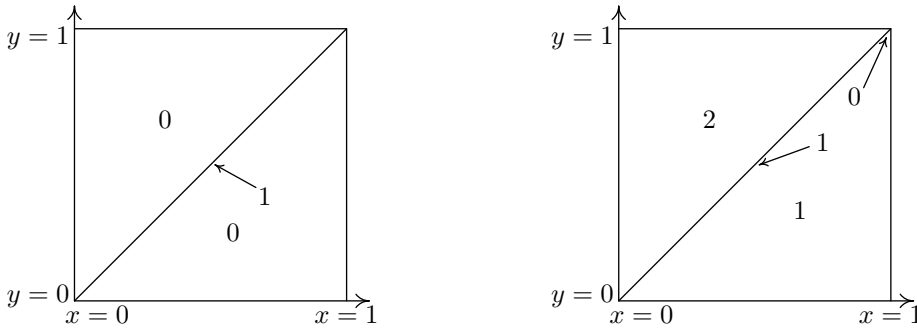

Figure 1: Representation of  $u_1(x, y)$  and  $u_2(x, y)$  in Example 7

$$u_1(x, y) = \begin{cases} 0 & \text{if } x \neq y \\ 1 & \text{if } x = y \end{cases}$$

$$u_2(x, y) = \begin{cases} 2 & \text{if } x < y \\ 1 & \text{if } x \geq y \text{ and } y \neq 1 \\ 0 & \text{if } x = y = 1 \end{cases}$$

This is a quasiconcave and compact diagonal game where condition (ii) of Proposition 6 is not satisfied. The game has no pure approximated equilibrium.

Importantly, continuity of  $f(x, y)$  only on the half space  $\{(x, y) \in [0, 1] \times [0, 1] : x < y\}$  may not guarantee the existence of an approximated equilibrium, as the following example shows.

**Example 8.** The following diagonal symmetric game is quasiconcave, compact and satisfies all assumptions but i), since here, the mapping  $f(x, y) = \frac{x}{y}$  has no continuous extension on  $[0, 1] \times [0, 1]$ .

$$u_1(x, y) = \begin{cases} \frac{x}{y} & \text{if } x < y \\ \frac{1}{2} \mathbf{1}_{x>0} & \text{if } x = y \\ \frac{1}{2} & \text{if } x > y \end{cases}$$

$$u_2(x, y) = u_1(y, x)$$

The game has no approximated pure equilibrium: indeed, no player  $i$  will play 0 at an  $\varepsilon$ -equilibrium (for  $\varepsilon < \frac{1}{2}$ ), since he would obtain 0, although he could guarantee  $1/2$  (playing 1 if the other player  $j$  plays  $y = 0$ , and just below  $y$  if  $y > 0$ ). Now, given a strategy  $x > 0$  of player  $i$ , player  $j$  should play some  $y$  just below  $x$  and get a payoff close to 1 while the other player obtains  $\frac{1}{2}$ . Consequently, no  $\varepsilon$ -equilibrium exists for  $\varepsilon < \frac{1}{2}$ . We can check that  $(x = (0, 0), v = (\frac{1}{2}, \frac{1}{2}))$  is the unique Reny equilibrium, and is also a  $\frac{1}{2}$ -equilibrium.

Our last example proves that Prokopovych's theorem cannot be applied to the class of diagonal games covered by Proposition 6.

**Example 9.** Consider the two-player game where the strategy spaces are  $X = Y = [0, 1]$ , and the payoff functions  $u_i$  are defined below:

$$u_1(x, y) = \begin{cases} 2 + x & \text{if } x < y \\ 1 & \text{if } x = y \\ 0 & \text{if } x > y \end{cases}$$

$$u_2(x, y) = y$$

This game satisfies the assumptions of Proposition 6. The only approximated equilibrium is  $(x = (1, 1), v = (3, 1))$  (which is, in our opinion, the natural solution of the game). However, Prokopovych's theorem cannot be applied, because  $V_1(x_2) = \sup_{d_1 \in [0, 1]} u_1(d_1, x_2)$  is discontinuous at  $x_2 = 0$ .

## 5 Games in Mixed Strategies

In this section, we introduce the concept of finite mixed deviation equilibrium. This equilibrium notion allows Reny and Simon-Zame results to be unified in mixed strategies and is applied to provide conditions under which a game admits a strategic approximation.

The fundamental idea of strategic approximation reveals itself to be extremely powerful in showing existence of Nash or approximated equilibrium, as will be seen in the framework of two-player diagonal games and auctions with incomplete information.

### 5.1 Finite Mixed Deviation Equilibria

Throughout this section,  $G$  is a metric compact game,  $G'$  denotes its mixed extension and  $\bar{\Gamma}'$  is the closure of the graph of  $G'$ .

**Definition 7**  $(m, v) \in \bar{\Gamma}'$  is a finite mixed deviation equilibrium if for every open set  $V_{m,v}$  that contains  $(m, v)$  and every finite set  $D_i \subset M_i$ ,  $i = 1, \dots, N$ , of mixed strategies, there exist finite sets  $D'_i \subset M_i$  containing  $D_i$  ( $i = 1, \dots, N$ ) and  $m'$ , a mixed Nash equilibrium of the game restricted to  $D'$ , such that  $(m', u(m')) \in V_{m,v}$ .

**Theorem 4.** Any metric compact game  $G$  admits a finite mixed deviation equilibrium.

**Proof.** The proof uses a finite discretization of the game, and a limit argument: let  $\mathcal{D}$  be the set of all finite subsets  $\Pi_{i \in N} D_i$  of  $M$ . Consider the inclusion relationship on  $\mathcal{D}$  (which is reflexive, transitive and binary). Then, each pair  $\Pi_{i \in N} D_i$  and  $\Pi_{i \in N} D'_i$  in  $\mathcal{D}$  has an upper bound  $\Pi_{i \in N} (D_i \cup D'_i)$  in  $\mathcal{D}$ . The couple  $(\mathcal{D}, \subset)$  is called a directed set. To every  $D = \Pi_{i \in N} D_i \in \mathcal{D}$ , we can associate  $(m^D, u(m^D))$ , where  $m^D$  is a Nash mixed equilibrium of the finite game restricted to  $D$ . This defines a mapping from  $\mathcal{D}$  to  $\bar{\Gamma}'$ , called a net (of  $\bar{\Gamma}'$ ). Then, a limit point  $(m, v) \in \bar{\Gamma}'$  of this net, denoted  $(m^D, u(m^D))_{D \in \mathcal{D}}$ , is defined by the following property: for every neighborhood  $V_{m,v}$  of  $(m, v)$  and every  $D = \Pi_{i \in N} D_i \in \mathcal{D}$ , there exists  $D' \in \mathcal{D}$  with  $D \subset D'$  such that  $(m^{D'}, u(m^{D'})) \in V_{m,v}$ . Such a limit point  $(m, v)$  exists due to compactness of  $\bar{\Gamma}'$ . Then  $(m, v)$  is clearly a finite mixed deviation equilibrium.

Similarly, if we require the deviations sets  $D_i$  and  $D'_i$  to be pure strategy sets in the definition of a finite mixed deviation equilibrium, we shall say that  $(m, v)$  is a finite pure deviations equilibrium (F.P.D.E). Its existence is proved similarly.

The concept of finite mixed deviation equilibrium is intuitive: it says that the mixed profile  $m$  with associated payoff vector  $v$  is “almost” a usual Nash mixed equilibrium. The concept requires that for any finite set of mixed deviations  $D_i \subset M_i$ , there is a profile  $m'$ , which is as close to  $m$  as desirable, with a payoff  $u(m')$  as close to  $v$  as desirable, such that  $m'$  is a Nash in a finite game  $D'$  larger than  $D$ .

**Definition 8**  $G$  has the weak finite deviation property if finite mixed deviation equilibria and Nash equilibria coincide.

A first motivation for this definition is to encompass the following class of games introduced by Reny [29], which generalizes better-reply security in mixed strategies as follows:

**Definition:**  $G$  has the *finite deviation property* if whenever  $m^* \in M$  is not a Nash equilibrium of  $G'$ , then there exists  $m^1, \dots, m^K \in M$  and a neighborhood  $U$  of  $m^*$  such that for all  $m' \in U$  there is a player  $i$  and  $k$  such that  $u_i(m_i^k, m'_{-i}) > u_i(m')$ .

**Theorem 5.**

- i) Every metric compact game which has the weak finite deviation property admits a Nash equilibrium.
- ii) For every mixed Nash equilibrium  $m$  of  $G'$ ,  $(m, u(m))$  is a finite mixed deviation equilibrium.
- iii)  $G$  is better reply-secure  $\Rightarrow G$  has the finite deviation property  $\Rightarrow G$  has the weak finite deviation property.

**Proof.** Property i) is a consequence of Theorem 4. To prove ii), let  $m$  be a mixed Nash equilibrium of  $G'$ ,  $V$  be an open neighborhood of  $(m, u(m))$  and  $D_i \subset M_i$ ,  $i = 1, \dots, N$ , be finite mixed strategy sets. Then  $m$  is a Nash equilibrium of  $\prod_{i \in N} (D_i \cup \{m_i\})$ , thus  $(m, u(m))$  is a finite mixed deviation equilibrium. Last, to prove the second implications of iii), assume  $G$  has the finite deviation property and  $m$  is not a Nash, then there exists  $m^1, \dots, m^K \in M$  and a neighborhood  $U$  of  $m$  such that for all  $m'$  there is a player  $i$  and  $k$  such that  $u_i(m_i^k, m'_{-i}) > u_i(m')$ . Let  $(m, v) \in \bar{\Gamma}'$ , let  $V$  be an open neighborhood of  $(m, v)$  such that  $(m', v) \in V$  implies  $m' \in U$ : this proves that  $(m, v)$  is not a finite mixed deviation equilibrium. The proof of the other statements is left to the reader.

The following theorem, proved in Appendix 8.2, shows that finite mixed deviation equilibrium unifies Simon-Zame and Reny existence results and so answers affirmatively to Jackson and Swinkel's question [19]. Also, keeping in mind that a finite mixed deviation equilibrium is nothing more than a limit point of Nash equilibria of a sequence of approximation of the game's strategy space, Theorem 6 makes precise the following idea in Reny [30]: “A rather distinct approach to approximating infinite games can be pursued by exploiting the techniques introduced in Simon and Zame, where payoffs are sometimes redefined at points of discontinuity.”

**Theorem 6.** Any finite mixed deviation equilibrium is a solution à la Simon-Zame and is a Reny equilibrium of the mixed extension of  $G$ .

The following example proves that finite mixed deviation equilibrium is a strict improvement of Reny equilibrium and Simon-Zame's solution.

**Example 10. (California location game, continued).** Let  $G = (X, Y, u_1, u_2)$  be the California location game, and consider the following modification  $\tilde{G} = (X, Y, \tilde{u}_1, \tilde{u}_2)$  of  $G$ :  $\tilde{u}_1(x, y) = u_1(x, y)$  if  $x$  is rational, and  $\tilde{u}_1(x, y) = 0$  otherwise. Similarly,  $\tilde{u}_2(x, y) = u_2(x, y)$  if  $y$  is rational, and  $\tilde{u}_2(x, y) = 0$  otherwise. Then every completely mixed strategy profile is a Reny and a solution à la Simon-Zame (associated to the payoff 0). This game is not quasiconcave, and the mixed extension is not better reply secure (because there is no Nash equilibrium). We now check that there is only one finite mixed deviation equilibrium  $(m, v)$ , for  $m = (3, 3)$  and  $v = (3, 1)$ , and this corresponds to the unique approximated equilibrium of this game. Indeed, for any finite discretization  $D_1^n$  and  $D_2^n$  of  $X$  and  $Y$ , and  $V$  any neighborhood of  $((3, 1), (3, 1))$ , define  $D_1'^n = D_1^n \cup \{3 - \varepsilon\}$  and  $D_2'^n = D_2^n \cup \{3\}$ . For  $\varepsilon > 0$  small enough,

$(3 - \varepsilon, 3)$  is a mixed Nash equilibrium of the finite game restricted to  $D_1^{\prime n} \times D_2^{\prime n}$ , with  $((3 - \varepsilon, 3), (3 - \frac{\varepsilon}{2}, 1 + \frac{\varepsilon}{2})) \in V$ .

## 5.2 Strategic Approximation

To understand the key idea of strategic approximation, we should come back to its origin. Simon and Zame construct their solution by taking a limit point of Nash equilibria of a sequence of discretizations. Dagsputa and Maskin [12] establish conditions under which limit points of Nash of *any* sequence of discretizations by finite games is a Nash mixed equilibrium of  $G$ . Simon [31] relaxes the requirement by establishing conditions under which any limit points of Nash of *some* sequence of discretizations by finite games is a Nash mixed equilibrium of  $G$ . In particular, he proves that any payoff secure and reciprocal upper semicontinuous compact and metric game in mixed strategies has this property. Reny [30] provides weaker conditions (close to better-reply security) under which a *strategic approximation* or a *finite-support strategic approximation* exist: here, a finite-support strategic approximation of  $G$  (resp. strategic approximation of  $G$ ) is a sequence of finite sets  $(D_i^n \subset X_i)_{i \in N}$  of *pure strategy* (resp.  $(D_i^n \subset M_i)_{i \in N}$  of *mixed strategies*) such that any limit point of Nash mixed equilibria of  $G^n = (D_i^n, u_i)_{i \in N}$  is a Nash mixed equilibrium of  $G$ .

In the previous subsection, we have introduced finite mixed deviation equilibrium, which has several useful properties: it exists, is a Nash for general classes of games, and permits Reny and Simon-Zame to be unified in mixed strategies. Thus, it is natural to try to extend the idea of strategic approximation to this equilibrium notion. First note that from the proof of the existence of a finite mixed deviation equilibrium  $m$  (Theorem 4) and the fact the  $\overline{\Gamma}$  is compact and metric, there exists some sequence  $\{D^n\}_n$  of finite subsets of  $M$  such that  $m$  is the weak limit of *some* sequence of Nash equilibria of the restriction of  $G$  to  $D_i^n$ . Could the approximation be chosen so that *any* limit point of any sequence of Nash equilibria is a finite mixed deviation equilibrium?

**Definition 9**  $G$  admits an F.M.D.E. strategic approximation if there is a sequence of finite sets  $\{D^n \subset M\}_n$  of mixed strategies such that for any larger sequence  $\{D_i^{\prime n} \supset D_i^n\}_n$ , any limit point of mixed equilibria of  $G^{\prime n} = (D_i^{\prime n}, u_i)_{i \in N}$  is an F.M.D.E of  $G$ .

**Theorem 10** Every compact-metric game admits an F.M.D.E. strategic approximation.

**Proof.** The proof is similar to the one in Reny [30] (Theorem 4.1). If  $(m, v) \in \overline{\Gamma}$  is not a finite mixed deviation equilibrium, then there is  $V^{(m, v)}$  a neighborhood of  $(m, v)$  and a finite set  $D$  such that for any  $D'$  that contains  $D$  and any equilibrium  $m'$  of the game restricted to  $D'$ ,  $(m', u(m'))$  is not in  $V^{(m, v)}$ . Thus, the set of non-finite mixed deviation equilibria is open. Consequently, there is a countable basis  $\{V^{(m_n, v_n)}\}_n$  that covers the set of non F.M.D.E, to which we can associate a sequence of finite sets  $\{D^n\}_n$ . Without any loss of generality, we can assume this sequence of sets to be increasing. Consequently, if  $\{m_n\}_n$  is a sequence of equilibria associated to  $D_i^{\prime n} \supset D_i^n$ , then  $(m_n, u(m_n))$  is not in  $V^{(m_k, v_k)}$  for all  $k \leq n$ . Consequently, every limit point of the sequence must be a finite mixed deviation equilibrium.

The following remarks are in order:

- For games with the weak finite deviation property (in particular for mixed better-reply secure games,



and for games with the finite mixed deviation property), an F.M.D.E. strategic approximation is a (Nash) strategic approximation of  $G'$  (thus, we obtain Theorem 4.1 in Reny [30]).

- Every sequence of Nash equilibria of the F.M.D.E. strategic approximation converges (up to a subsequence) to a solution à la Simon-Zame (just use in the proof of theorem 6 the F.M.D.E. strategic approximation).
- Theorem 10 can be extended to Reny's finite support deviation property as follows. For every compact-metric game, there exists an F.P.D.E. strategic approximation defined as follows: a sequence of finite sets  $(D_i^n \subset X_i)_{i \in N}$  of **pure strategies** such that any limit point of mixed equilibria of  $G^n = (D_i^n, u_i)_{i \in N}$  is a finite pure deviation equilibrium of  $G$ . Consequently, for games for which F.P.D.E. and mixed Nash equilibria coincide (in particular for games with the finite pure deviation property), an F.M.D.E. strategic approximation is a finite-support strategic approximation of  $G'$  à la Reny (which gives Theorem 5.1 in Reny [30]).

The same logic applies to approximated equilibria: for games in which finite mixed deviation equilibria and approximated equilibria coincide, we obtain the existence of an *approximated strategic approximation*, defined as follows.

**Definition 11** *A game  $G$  has an approximated strategic approximation if there is a sequence of mixed discretizations whose mixed equilibria have approximated equilibria of  $G$  as accumulation points.*

What should be concluded? A more general approach to prove that a game admits an approximated equilibrium, consists in finding a strategic approximation instead of checking that it is approximately better-reply secure. The following proposition illustrates this idea:

**Proposition 12** *Any diagonal game where  $f$ ,  $g$  and  $h$  are continuous admits an approximated strategic approximation and, consequently, an approximated equilibrium in mixed strategies.*

The proposition, proved in Appendix 8.3, extends a similar result in Laraki et al. [22] for timing games. Some remarks are of importance:

- Laraki et al. [22] provide a 3-player timing game without approximated mixed equilibrium. Thus, the existence result above does not extend to 3-player diagonal games without additional assumptions.
- The well-known Sion-Wolfe's [33] zero-sum game on the square without a value shows that the existence of an approximated equilibrium fails when the game admits two lines of discontinuities instead of only one (the diagonal).
- The proof and so the result could be extended to two-player games on the square where discontinuities are along a one dimensional curve given by some continuous one-to-one function  $y = \phi(x)$  instead of the diagonal  $y = x$ . A similar observation could be made in pure strategies. This allows coverage of games such as the California location game (which can easily be mapped to a quasiconcave compact game on the square with one line of discontinuity).

In applications such as auctions, diagonal games are of incomplete information. It is thus natural to study the following extension of the previous model.

**Example 11.** A diagonal game with incomplete information is defined as follows. There are two players. Each player  $i$  has a finite set of types  $T_i$ . At stage 0, a profile of types  $t = (t_1, t_2)$  is drawn according to some **joint** probability distribution  $p$  on  $T = T_1 \times T_2$ , and each player  $i$  is informed about his own type  $t_i$ . At stage 1, players chose simultaneously an element in the unit interval  $[0, 1]$  (bid, time, price, quantity, location, etc.). The payoff function of player  $i$  type-dependent is:

$$u_i(t_i, t_j, x_i, x_j) = g_i(t_i, t_j, x_i, x_j) \mathbf{1}_{x_i > x_j} + f_i(t_i, t_j, x_i, x_j) \mathbf{1}_{x_i < x_j} + h_i(t_i, t_j, x) \mathbf{1}_{x_i = x_j = x}.$$

The following proposition is proved in Appendix 8.4

**Proposition 13** *Any diagonal game with incomplete information that satisfies conditions i), ii) and iii) below admits an approximated strategic approximation and, consequently, an approximated mixed equilibrium, where:*

- i) *there is  $i = 1, 2$  such that for all  $t = (t_i, t_j) \in T$ ,  $h_i(t_i, t_j, 0) \leq g_i(t_i, t_j, 0, 0)$ ;*
- ii) *there is  $i = 1, 2$  such that for all  $t_i \in T_i$ ,  $x = 1$  is never the unique best response of  $t_i$ ;*
- iii)  *$f$  and  $g$  are continuous.*

All standard models of auctions satisfy the following: a) if the other player bids 0, it is always better to bid slightly more and win the auction at almost no cost; b) Assumption ii) is satisfied whenever all values for all types are strictly smaller than the maximal bid (here  $x = 1$ ). For example  $x = 1$  is weakly dominated in second price auctions and strictly dominated in first price and all-pay auctions.

Some remarks are of importance:

- First price auction with complete information has no Nash equilibrium and it is generally admitted in the community that the player with the highest value must bid a little bit higher than the second highest value. This is an approximated equilibrium.
- Fanga and Morris [15] provide a two-player type dependent first price auction and independent values without a Nash equilibrium. Our proposition implies that their game has an approximated equilibrium.
- As the proof shows, Proposition 13 is still valid if ii) is replaced with:  
ii') there is  $i = 1, 2$  such that for all  $t = (t_i, t_j) \in T$ ,  $h_i(t_i, t_j, 1) \geq f_i(t_i, t_j, 1, 1)$ .

This condition is satisfied in first and second price auctions but *not* in all-pay auctions. That is why our proposition is stated with Condition i).

- The strategic approximation constructed in the proof is such that there will be zero probability that the two players submit the same bid. The resulting approximated equilibrium is thus independent on the value of the tie-breaking rule  $h$ , as soon as assumption i) is satisfied.

- Barelli et al. [4] combine tie-breaking rules and better-reply security ideas to prove existence of Nash or approximated equilibria in a general class of zero-sum games including majority voting and Colonel Blotto games.

The following is a minimal counterexample showing that without assumptions i) or ii), an approximated equilibrium fails to exist!

**Example 12.**

We consider a zero-sum timing game which may be viewed as a diagonal game with constant payoff functions  $f$ ,  $g$  and  $h$ .

Each player should decide when to stop the game between 0 and 1. The game stops at the first moment when one of the two players stops. If both players stop simultaneously before the exit time  $t = 1$  or no player stops before time  $t = 1$ , then there is a tie (payoff is given by  $h$ ).

Player 2 has two types  $A$  and  $B$  with equal probabilities. Player 1 has only one type. If player 1 stops first he gets  $f = 1$ . If player 1 stops second he gets  $g = -1$ . Only the payoff when the players stop simultaneously depend on the type of player 2. If the type is  $A$ , player 1 has an advantage and gets the payoff  $h = 3$  and if the type is  $B$ , player 1 has a disadvantage and gets the payoff  $h = -2$ .

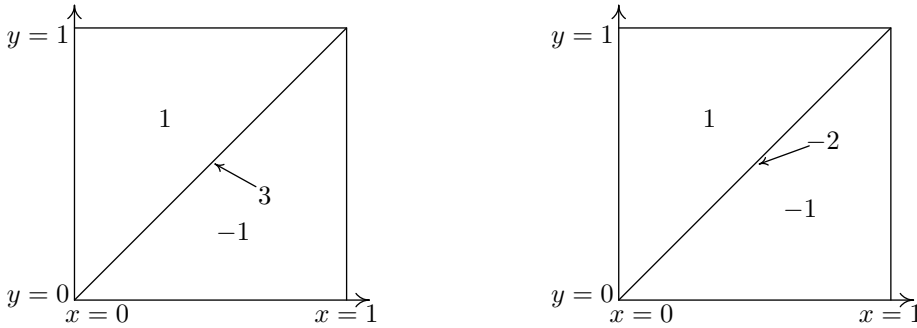

Figure 1: Representation of  $u_1(x, y)$  of type A and B.

Let us show that the  $\max \min \leq -\frac{1}{2}$  and that the  $\min \max \geq -\frac{1}{4}$ , so that the game has no value and so no approximated equilibrium.

Start with the maxmin. Let  $\alpha$  be the probability with which player 1 stops at  $x = 0$  (so with probability  $(1 - \alpha)$  he stops after zero). If  $\alpha = 0$ , player 2 by stopping at time zero gets 1 (and so player 1 gets  $-1$ ). If  $\alpha > 0$ , type  $A$  for player 2 can stop uniformly between 0 and some  $\epsilon$  where  $\epsilon$  is very small so that with high probability, if the game has not been stopped at time zero, he is stopped by player 2 (just after zero). Assume that type  $B$  of player 2 stops at time zero. Payoff of player 1 is thus very close to  $\alpha(\frac{1}{2} \times 1 + \frac{1}{2} \times -2) + (1 - \alpha) \times -1$ . Consequently, the best strategy for player 1 against such behavior by player 2 is to stop at  $t = 0$  with probability 1 so that  $\max \min \leq -\frac{1}{2}$ .

Let us now compute the min max. Let us restrict player 1 to playing best-replies to the following set of strategies : (1) to stop at time  $t = 0$  or (2) to stop uniformly between 0 and some  $\epsilon$  very small, which depends of course on the strategy of player 2. Knowing this behavior, type  $B$  must stop at time zero. Let  $\beta$  be the probability that type  $A$  stops at time zero. The payoff of player 1 if he stops at 0 (choose option 1) is  $\frac{1}{2} \times -2 + \frac{1}{2} \times (\beta \times 3 + (1 - \beta) \times 1) = -\frac{1}{2} + \beta$ , while if he chooses option 2 his payoff is close to  $\frac{1}{2} \times -1 + \frac{1}{2}(\beta \times -1 + (1 - \beta) \times 1) = -\beta$ . Thus, the optimal  $\beta$  for type B against this behavior of player 1 must be equalizing and so is  $\beta = \frac{1}{4}$ . Consequently,  $\min \max \geq -\frac{1}{4}$ .

## 6 Some Extensions in Pure Strategies

There have been many extensions of Reny's B.R.S. existence result. In this section, we explain how to adapt the previous results and deal with these extensions.

### 6.1 Barelli-Soza Equilibrium

The Reny security condition is strong: it asks for existence of a deviation  $d_i$  with the property that  $u_i(d_i, x'_{-i}) > v_i$  for every  $x'$  in some neighborhood of  $x$ . Barelli and Soza propose a natural improvement: they just allow  $d_i$  to depend continuously on  $x'_{-i}$ , meaning that  $u_i(d_i(x'_{-i}), x'_{-i}) > v_i$  for every  $x'$  in some neighborhood of  $x$ , where  $d_i(\cdot)$  is a continuous function from a neighborhood of  $x_{-i}$  to  $X_i$ .

In fact, Barelli and Soza go further and ask for existence of a ‘‘Kakutani’’ multivalued mapping<sup>9</sup>  $\Phi_i(\cdot)$  from a neighborhood of  $x_{-i}$  to  $X_i$ , such that  $u_i(d'_i, x'_{-i}) > v_i$  for every  $x'$  in some neighborhood of  $x$  and every  $d'_i \in \Phi_i(x'_{-i})$ .

**Definition (Barelli-Soza [3, 5]):** a game  $G$  is *generalized better-reply secure* if whenever  $(x, v) \in \bar{\Gamma}$  and  $x$  is not a Nash equilibrium, then there is a player  $i$ , a neighborhood  $U$  of  $x_{-i}$ ,  $\Phi_i$  a Kakutani's mapping from  $U$  to  $X_i$ , and  $\alpha_i > v_i$ , such that for every  $x'$  in the graph of  $\Phi_i$ ,  $u_i(x') > \alpha_i$ .

Then Barelli and Soza prove the following theorem.

**Barelli-Soza's theorem [3, 5]:** if  $G$  is quasiconcave, compact and generalized better-reply secure, then it admits a Nash equilibrium.

In Section 2, Reny's better-reply security assumption is defined using the lower semicontinuous regularization  $\underline{u}_i$  of  $u_i$ . Similarly, one can define generalized better-reply security using the following subtle regularization  $\underline{\underline{u}}_i$  of  $u_i$ :

$$\forall (x_i, x_{-i}) \in X, \underline{\underline{u}}_i(x_i, x_{-i}) := \sup_{U \in \mathcal{V}(x_{-i})} \sup_{\Phi_i \in W_U(x_i, x_{-i})} \inf_{x' \in Gr \Phi_i} u_i(x'), \quad (1)$$

where  $\mathcal{V}(x_{-i})$  denotes the set of neighborhoods of  $x_{-i}$  and  $W_U(x_i, x_{-i})$  is the set of multi-valued mappings  $\Phi_i$  from  $U$  to  $X_i$  such that  $x_i \in \Phi_i(x_{-i})$ , and which are Kakutani mapping.

From the definition of  $\underline{\underline{u}}_i$ ,  $G$  is generalized better-reply secure if whenever  $(x, v) \in \bar{\Gamma}$  and  $x$  is not a Nash equilibrium, then there is a player  $i$  and  $d_i \in X_i$  such that

$$\underline{\underline{u}}_i(d_i, x_{-i}) > v_i.$$

In the spirit of Definition 2, we can define.

**Definition 14** A *Barelli-Soza equilibrium* is a couple  $(x, v) \in \bar{\Gamma}$  such that:

$$\forall i \in N, \sup_{d_i \in X_i} \underline{\underline{u}}_i(d_i, x_{-i}) \leq v_i.$$

<sup>9</sup> $\Phi_i$  is a Kakutani mapping if it has a closed graph, with non-empty and convex values.

From Barelli-Soza's Theorem above, we deduce the existence of a Barelli-Soza equilibrium (exactly as we have deduced the existence of a Reny equilibrium from Reny's existence result).<sup>10</sup> Similarly, we can refine the existence of a sharing-rule equilibrium, substituting  $\underline{u}_i$  for  $u_i$  in Definition 1.

Finally, observe that Barelli-Soza equilibrium refines Reny equilibrium simply because  $\underline{u}_i \leq \underline{u}_i$  (one can take constant mappings  $\Phi_i = x_i$  in the supremum of Equation (1) above). This is a strict refinement as the following example shows.

**Example 13.** Consider a two-player diagonal game with  $X_1 = X_2 = [0, 1]$ ,  $u_i(x_i, x_{-i}) = 0$  if  $x_i \neq x_{-i}$  and  $u_i(x_i, x_{-i}) = 1$  otherwise. Every strategy profile is a Reny equilibrium, because  $\underline{u}_i = 0$  for every  $i$ , and  $u_i = 0$  on a dense subset of  $X$ . On the other hand, the set of Barelli-Soza equilibria, which coincides with the set of Nash equilibria, is equal to the diagonal. Indeed,  $\underline{u}_i = u_i$  for every  $i$ , since for every  $(x_i, x_i)$ , we can take  $\Phi_i(x'_{-i}) = x'_{-i}$  in the supremum of Equation (1).

Note that it is not possible to skip the Kakutani regularity requirement on  $\Phi_i$  in Definition 14, and still have existence, as it is proved in Appendix 8.7.

The existence of a Barelli-Soza equilibrium drives to a re-interpretation of generalized better-reply security notion, since a game  $G$  is generalized better-reply secure if and only if the set of Nash equilibria and the set of Barelli-Soza equilibria coincide. But the interest of Barelli-Soza equilibrium goes beyond this: as for Reny equilibrium, this is a tool to prove the existence of approximated equilibria. The following class of diagonal games, which differs from the class of Proposition 6, is an illustration.

**Proposition 15** *For any quasiconcave diagonal game such that  $f_i$ ,  $g_i$  and  $h_i$  are continuous, Barelli-Soza and approximated equilibria coincide (so that the game admits an approximated equilibrium).*

This result (proved in Appendix 8.5) is not covered by Barelli-Soza existence result, because some games in the class may possess no Nash equilibrium, as the following example illustrates. Consider the quasiconcave two-player diagonal game where the strategy spaces are  $X = Y = [0, 1]$ , and the payoff functions  $u_i$  are defined by

$$u_1(x, y) = \begin{cases} 1 + x - y & \text{if } x < y \\ 0 & \text{if } x = y \\ -1 & \text{if } x > y \end{cases}$$

$$u_2(x, y) = y.$$

The only optimal strategy of player 2 is  $y = 1$ , which gives no optimal strategy for player 1. Thus, there is no Nash equilibrium, although  $f_i$ ,  $g_i$  and  $h_i$  are continuous. On the other hand, there is an approximated equilibrium  $(x = (1, 1), v = (1, 1))$ , since  $(1 - \varepsilon, 1)$  is  $\varepsilon$ -optimal for player 1 and optimal for player 2. We let the reader check that it is the unique approximated equilibrium, and also the unique Barelli-Soza equilibrium.

<sup>10</sup>In Appendix 8.6 is given an independent proof of the existence of a Barelli-Soza equilibrium. As a matter of fact, it proves the existence of a *tight equilibrium* (defined in Section 6.3), which refines simultaneously Barelli-Soza equilibrium, and a recent extension of Reny's work ([29]).

## 6.2 Non-Quasiconcave Payoffs

Many games in the literature have non-quasiconcave and discontinuous payoff functions, while they still have a Nash or an approximated equilibrium in pure strategies. This subsection explains how the tools presented in the last sections can be adapted to that case, using a quasi-concavification approach. This also provides a new interpretation of some recent existence results in the literature [5, 8, 24].

For every game  $G = ((X_i)_{i \in N}, (u_i)_{i \in N})$ , we define the quasiconcave game  $qcav(G)$  as

$$qcav(G) = ((X_i)_{i \in N}, (qcav(u_i))_{i \in N})$$

where for every  $x_{-i} \in X_{-i}$ ,  $qcav(u_i)(\cdot, x_{-i})$  is the quasiconcave envelop of  $u_i(\cdot, x_{-i})$  with respect to player  $i$ 's strategy profile, i.e. the smallest quasiconcave mapping above  $u_i(\cdot, x_{-i})$ .<sup>11</sup>

**Definition 16** *For every game  $G$ , a quasi-equilibrium of  $G$  is a Reny equilibrium of  $qcav(G)$ .*

From Theorem 1, we derive for every game  $G$  the existence of a quasi-equilibrium.

This leads to many Nash existence results in the literature. By defining the class of games  $G$  for which the set of Nash and quasi-equilibria coincide, one obtains the class of strongly better-reply secure games introduced by Bich ([8]). The existence results in Barelli-Soza [3] and McLennan et al. [24] can be obtained from the quasiconcave case, in a similar way.

As an application, consider a standard Hotelling game.

**Example 14.** On a line of length  $l$ , two sellers  $i = 1, 2$  of a homogeneous product are located at  $\frac{l}{2} - \varepsilon$  and  $\frac{l}{2} + \varepsilon$ , where  $\varepsilon \in [0, \frac{l}{2}]$ . For simplicity, we consider only the symmetric case. Customers are supposed to be uniformly distributed on  $[0, l]$ , and each customer chooses the seller with the lowest delivery price. Let  $c$  be the transportation rate, and  $p_i$  the mill price of seller  $i$  (who is player  $i$ ). Under standard assumptions, the payoff of player  $i$  can be written:

$$u_i(p_i, p_{-i}) = \frac{l}{2}p_i + \frac{p_i(p_{-i} - p_i)}{2c} \quad \text{if } |p_i - p_{-i}| \leq 2c\varepsilon,$$

$$u_i(p_i, p_{-i}) = lp_i \quad \text{if } p_i < p_{-i} - 2c\varepsilon$$

and

$$u_i(p_i, p_{-i}) = 0 \quad \text{if } p_i > p_{-i} + 2c\varepsilon.$$

D'Aspremont et al. [14] proved that there exists no equilibrium when sellers are close to each other (more precisely, when  $\varepsilon < \frac{l}{4}$ ). Remarkably, this is exactly the case for which Nash and quasi-equilibria coincide, as the following proposition states.

**Proposition 17** *The set of Nash and quasi-equilibria of  $G$  coincide in the Hotelling game if and only if  $\varepsilon \geq \frac{l}{4}$  (which holds from [14] if and only if  $G$  has a Nash equilibrium).*

<sup>11</sup>Formally,

$$qcav(u_i)(x) = \sup\{\min\{u_i(y_k, x_{-i})\}_{k=1}^n\},$$

where the supremum is taken over all  $n \in \mathbb{N}^*$  and all families  $\{y_1, \dots, y_n\}$  of  $X_i$  such that  $x_i \in \text{co}\{y_1, \dots, y_n\}$ . Hence, the game  $G$  is quasiconcave if and only if  $qcav(u_i) = u_i$  for every  $i \in N$ .

The following points explain the proposition and provide more details (the formal proofs of our statement are left to the reader).

- For  $\varepsilon \in [\frac{l}{4}, \frac{l}{2}]$ ,  $(cl, cl)$  is the only Nash and quasi-equilibrium of  $G$ : the payoff of player  $i$  (given the Nash strategy  $cl$  of the other player  $-i$ ) is represented on Figure 1, 2 and 3.

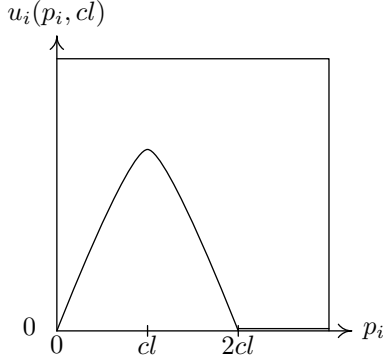

Figure 1: Graph of  $u_i(\cdot, cl)$  for  $\varepsilon = \frac{l}{2}$ .

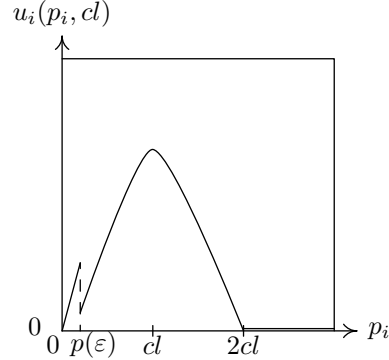

Figure 2: Graph of  $u_i(\cdot, cl)$  for  $\varepsilon \in ]\frac{l}{2}, \frac{l}{4}[$ , where  $p(\varepsilon) = cl - 2c\varepsilon$ .

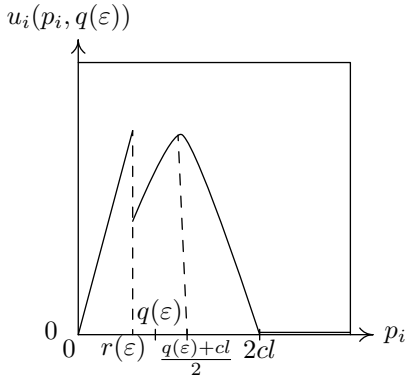
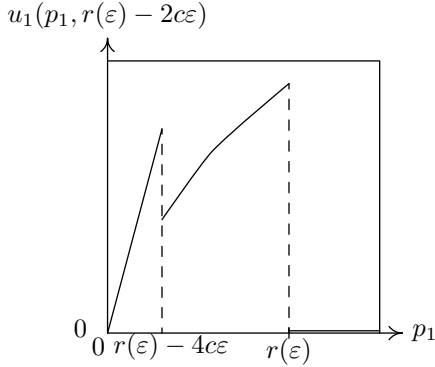

Figure 3: Graph of  $u_i(\cdot, q(\varepsilon))$  for  $\varepsilon \in [0, \frac{l}{4}]$ ,

where  $r(\varepsilon) = q(\varepsilon) - 2c\varepsilon$  and

$$q(\varepsilon) = 3cl - \sqrt{8c^2l^2 - 16c^2l\varepsilon}.$$

- For  $\varepsilon \in ]\frac{l}{4+\sqrt{20}}, \frac{l}{4}[$ , the only quasi-equilibrium is  $(q(\varepsilon), q(\varepsilon))$  where  $q(\varepsilon) = 3cl - \sqrt{8c^2l^2 - 16c^2l\varepsilon}$ ; it is not a Nash equilibrium. For every  $\eta > 0$ , it provides an  $\eta$ -equilibrium for  $\varepsilon < \frac{l}{4}$  close enough to  $\frac{l}{4}$ .
- For  $\varepsilon \in [0, \frac{l}{4+\sqrt{20}}]$ , the situation is more complicated:  $(q(\varepsilon), q(\varepsilon))$  is also a quasi-equilibrium, but there can be more. For example,  $(r(\varepsilon), r(\varepsilon) - 2c\varepsilon)$  or  $(r(\varepsilon) - 2c\varepsilon, r(\varepsilon))$  are quasi equilibria, where  $r(\varepsilon) = \frac{3lc\varepsilon - 2c\varepsilon^2}{\frac{l}{2} + \varepsilon}$ . The following Figure 4 illustrates the example of  $(r(\varepsilon), r(\varepsilon) - 2c\varepsilon)$  (which is not a Nash equilibrium); player 1 strategy is optimal, and player 2 strategy is close to an optimal strategy, in the sense that it is the limit of an  $\varepsilon$ -optimal strategy when  $\varepsilon$  tends to 0. For every  $\eta > 0$ , it provides an  $\eta$ -equilibrium for  $\varepsilon > 0$  small enough.



Graph of  $u_1(\cdot, r(\varepsilon) - 2c\varepsilon)$  for  $\varepsilon \leq \frac{l}{4+\sqrt{20}}$

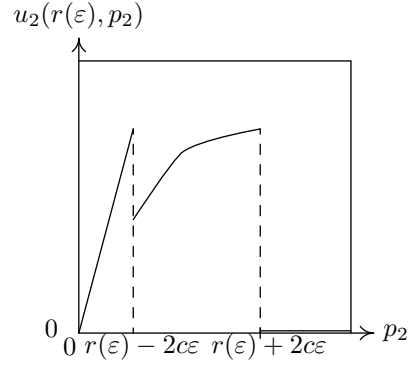

Graph of  $u_2(r(\varepsilon), \cdot)$  for  $\varepsilon \leq \frac{l}{4+\sqrt{20}}$ .

Recall that in his seminal paper, Hotelling proposes  $(cl, cl)$  as a Nash equilibrium even for  $\varepsilon < \frac{l}{4}$ , although it is not even a quasi-equilibrium.

### 6.3 Reny's Lower Single Deviation Property

Reny proposes the following refinement of better-reply security.

**Definition (Reny [29]):**  $G$  has the *lower single deviation property* if whenever  $x \in X$  is not a Nash equilibrium, there exists  $d \in X$  and a neighborhood  $V$  of  $x$  such that for every  $z \in V$ , there exists a player  $i$ , such that

$$\forall x' \in V, \underline{u}_i(d_i, x'_{-i}) > \underline{u}_i(z)$$

Then Reny proves the following.

**Reny's theorem [29]:** Any quasiconcave, compact game that has the lower single deviation property admits a Nash equilibrium.

Note that if  $G$  is better-reply secure, then it has the lower single deviation property. Indeed, by contradiction, assume that there exists  $x \in X$  which is not a Nash equilibrium and such that for every  $d \in X$  and every neighborhood  $V$  of  $x$ , there exists  $z \in V$  such that for every player  $i$ , there exists  $x' \in V$  such that:

$$\underline{u}_i(d_i, x'_{-i}) \leq \underline{u}_i(z) \leq u_i(z)$$

Then, shrinking  $V$  to  $x$  in the above equation, and taking  $v$  to be a limit in the sense of nets of  $u(z)$ , we obtain easily that  $(x, v)$  is a Reny equilibrium, thus a Nash equilibrium, which is contradictory.

The following example proves that lower single deviation property is a strict refinement of better-reply security:

**Example 15.** Consider a two-player diagonal game with  $X_1 = X_2 = [0, 1]$ ,



$$u_1(x, y) = \begin{cases} 0 & \text{if } x < y \text{ or } (x, y) = (0, 0) \\ 1 - x & \text{if } x = y > 0 \\ 1 & \text{if } x > y \end{cases}$$

and  $u_2(x, y) = u_1(y, x)$ .

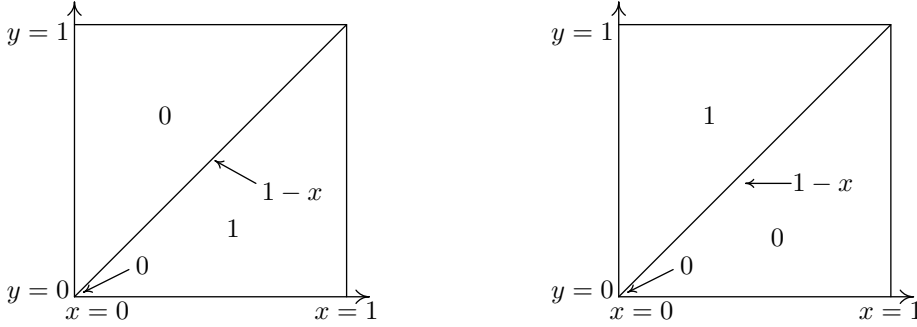

Figure 1: Representation of  $u_1(x, y)$  and  $u_2(x, y)$  in Example 15

$G$  is neither better-reply secure nor generalized better-reply secure. Indeed, consider the sequence of strategy profile  $(\frac{1}{n}, \frac{1}{n})$ . At the limit we get  $(x, v) = ((0, 0), (1, 1)) \in \bar{\Gamma}$ . No player can secure strictly more than 1 at  $(0, 0)$ , although  $(0, 0)$  is not a Nash equilibrium. On the other side, this game has the lower single deviation property, since one has

$$\underline{u}_1(x, y) = \begin{cases} 0 & \text{if } x \leq y \\ 1 & \text{if } x > y \end{cases}$$

and

$$\underline{u}_2(x, y) = \underline{u}_1(y, x) \text{ for every } (x, y) \in [0, 1] \times [0, 1],$$

and we let the reader check that  $G$  has the lower single deviation property, taking  $d = (1, 1)$  in the definition.

In this subsection, we provide a refinement of Reny equilibrium that implies the two refinements above (Reny and Barelli-Soza).<sup>12</sup> First define, for every  $\Phi_i \in W_U(x_i, x_{-i})$ :

$$u_i^{\Phi_i}(x_i, x_{-i}) := \sup_{U \in \mathcal{V}(x_{-i})} \inf_{x' \in G \cap \Phi_i} u_i(x'), \quad (2)$$

**Theorem 7.** *Every quasiconcave and compact game  $G$  admits a **tight equilibrium**: that is, there exists  $x \in X$  such that for every neighborhood  $V$  of  $x$  and every  $(\Phi_i)_{i \in N}$  in  $\prod_{i \in N} W_V(x_{-i})$ , there exists  $z \in V$  such that for every  $i \in N$  there exists  $x' \in V$  and  $d'_i \in \Phi_i(x'_{-i})$  such that  $u_i^{\Phi_i}(d'_i, x'_{-i}) \leq u_i(z)$ .*

The proof is given in Appendix 8.6, and is the direct consequence of a new selection lemma combined with Kakutani [20] fixed-point theorem. Note the following consequences:

<sup>12</sup>Our refinement can be adapted to the non-quasiconcave case, as explained in the previous subsection, so that it covers most of the recent literature.

- For every player  $i$  and every  $d_i \in X_i$ , if we take  $\Phi_i(x'_{-i}) = d_i$  above, we obtain as a particular case the existence, for every quasiconcave and compact game  $G$ , of  $x \in X$  such that: for every neighborhood  $V$  of  $x$  and every  $d \in X$ , there exists  $z \in V$  such that for every  $i \in N$ , there exists  $x' \in V$  such that  $\underline{u}_i(d_i, x'_{-i}) \leq u_i(z)$ . Applying this to the payoff functions  $\underline{u}_i$  (which has the same quasiconcavity property as  $u_i$ ), we obtain the existence of a Nash equilibrium when the game has the lower single deviation assumption, as the reader can check.
- Shrinking  $V$  to  $x$  in the definition of a tight equilibrium, and taking  $v$  to be a limit in the sense of nets of  $u(z)$ , we obtain the existence of a Barelli-Soza equilibrium  $(x, v)$ .

As a consequence, our paper is mathematically self contained.

## 7 Conclusion

The main contribution of this paper is to propose a unifying framework that encompasses Simon-Zame and Reny in pure and mixed strategies, and to apply it to obtain new existence results of approximated Nash equilibria. We think that it makes more explicit the relationship between better-reply security, sharing-rules and approximated equilibria. In particular, the limit payoff in Reny's better-reply security can be interpreted as a tie-breaking rule, but also, for a large number of games, as a limit of payoffs of approximated equilibria. In the future, an important question would be to characterize more precisely the class of approximately better-reply secure games.

## 8 Appendix

### 8.1 Proof of Proposition 6

We first need the following lemma:

**Lemma 18** *Let  $G = ((f_i, g_i, h_i)_{i=1,2})$  be a diagonal game satisfying i) and ii) of Proposition 6. Then:*

- $G$  is payoff secure at every  $x$ . In particular,  $\sup_{d_i \in [0,1]} u_i(d_i, x_{-i}) = \sup_{d_i \in [0,1]} \underline{u}_i(d_i, x_{-i})$ .*
- For every  $x_{-i} \in ]0, 1[$ , the function  $V_i(x_{-i}) = \sup_{d_i \in [0,1]} u_i(d_i, x_{-i})$  is continuous at  $x_{-i}$ .*
- For every  $i = 1, 2$ , if  $f_i(0, 0) \leq g_i(0, 0)$  then  $V_i(x_{-i})$  is continuous at  $x_{-i} = 0$ .*
- For every  $i = 1, 2$ , if  $f_i(0, 0) > g_i(0, 0)$  then:*
  - for every  $\varepsilon > 0$ ,  $\sup_{d_i \in [0,1]} u_i(d_i, x_{-i}) \leq u_i(0, x_{-i}) + \varepsilon$  for  $x_{-i} > 0$  small enough.*
  - $\sup_{d_i \in [0,1]} u_i(d_i, 0) = u_i(0, 0)$ . In particular, if  $f_i(0, 0) > g_i(0, 0)$  is true for both players, then  $(0, 0)$  is a Nash equilibrium.*

**Proof of Lemma 18.** a) First remark that  $G = ((f_i, g_i, h_i)_{i=1,2})$  is payoff secure at every  $x = (x_i, x_{-i}) \in [0, 1] \times [0, 1]$  for which  $x_i \neq x_{-i}$  (because the payoff functions  $u_i$  are continuous at such  $x$ ). Thus, we have to prove payoff security at  $(x_i, x_i) \in [0, 1] \times [0, 1]$ . First assume  $x_i \in ]0, 1[$ . From  $h_i(x_i, x_i) \in \text{co}\{f_i(x_i, x_i), g_i(x_i, x_i)\}$ , for every  $\varepsilon > 0$ , player  $i$  can secure  $u_i(x_i, x_i) - \varepsilon = h_i(x_i, x_i) - \varepsilon$ , playing  $x_i + \eta$  or  $x_i - \eta$  (for  $\eta$  small enough). We now treat the case  $x_i = 0$ : from  $h_i(0, 0) \in \text{co}\{f_i(0, 0), g_i(0, 0)\}$ , either  $h_i(0, 0) \leq g_i(0, 0)$ , and player  $i$  can secure  $u_i(0, 0) - \varepsilon$  (playing  $x_i + \eta$  for  $\eta$  small enough), or

$h_i(0,0) \leq f_i(0,0)$ : in this case, player  $i$  can secure  $u_i(0,0) - \varepsilon = h_i(0,0) - \varepsilon$ , playing  $(0,0)$ , because for  $\eta > 0$  small enough,  $u_i(0,\eta) = f_i(0,\eta) > h_i(0,0) - \varepsilon$ .

b) Let  $x_{-i} \in ]0,1[$ . From  $h_i(x_i, x_i) \in \text{co}\{f_i(x_i, x_i), g_i(x_i, x_i)\}$  and from the continuity of  $f_i$  and  $g_i$ , we get

$$V_i(x_{-i}) := \sup_{d_i \in [0,1]} u_i(d_i, x_{-i}) = \max\left\{ \sup_{d_i \in [0, x_{-i}]} f_i(d_i, x_{-i}), \sup_{d_i \in [x_{-i}, 1]} g_i(d_i, x_{-i}) \right\}. \quad (3)$$

Thus, from Berge Maximum Theorem (see [1]), the mapping  $\sup_{d_i \in [0,1]} u_i(d_i, x_{-i})$  is continuous at every  $x_{-i} \in ]0,1[$ .

c) Suppose  $f_i(0,0) \leq g_i(0,0)$  for some  $i \in \{1,2\}$ . From  $h_i(0,0) \in \text{co}\{f_i(0,0), g_i(0,0)\}$ , we get  $f_i(0,0) \leq h_i(0,0) \leq g_i(0,0)$ . Fix  $\varepsilon > 0$ . Since  $f_i$  and  $g_i$  are continuous, we obtain

$$h_i(x_i, x_i) \leq g_i(x_i, x_i) + \varepsilon \quad (4)$$

and

$$f_i(x_i, x_i) \leq g_i(x_i, x_i) + \varepsilon \quad (5)$$

for  $x_i$  small enough.

The definition of  $u_i$ , the continuity of  $g_i$  and  $h_i(0,0) \leq g_i(0,0)$  give, for  $x_i \geq 0$  small enough:

$$\sup_{d_i \in [0,1]} u_i(d_i, 0) = \max\{h_i(0,0), \sup_{d_i \in [0,1]} g_i(d_i, 0)\} = \sup_{d_i \in [0,1]} g_i(d_i, 0) \geq \sup_{d_i \in [0,1]} g_i(d_i, x_i) - \varepsilon \quad (6)$$

From the continuity of  $f_i$  and  $g_i$ , and from Inequalities 4 and 5, we get, for  $x_i > 0$  small enough:

$$\sup_{d_i \in [x_i, 1]} g_i(d_i, x_i) \geq g_i(x_i, x_i) > h_i(x_i, x_i) - \varepsilon \quad (7)$$

and

$$\sup_{d_i \in [x_i, 1]} g_i(d_i, x_i) \geq g_i(x_i, x_i) \geq \sup_{d_i \in [0, x_i]} f_i(d_i, x_i) - 2\varepsilon \quad (8)$$

Consequently, from the definition of  $u_i$ , the previous inequalities imply

$$\sup_{d_i \in [0,1]} u_i(d_i, x_i) = \max\left\{ \sup_{d_i \in [0, x_{-i}]} f_i(d_i, x_{-i}), h_i(x_i, x_i), \sup_{d_i \in [x_{-i}, 1]} g_i(d_i, x_{-i}) \right\} \leq \sup_{d_i \in [0,1]} g_i(d_i, x_i) + 2\varepsilon \quad (9)$$

for  $x_i > 0$  small enough. From Inequalities 6 and 9, we get

$$\sup_{d_i \in [0,1]} u_i(d_i, x_i) \leq \sup_{d_i \in [0,1]} u_i(d_i, 0) + 3\varepsilon$$

for  $x_i \geq 0$  small enough, which proves that  $V_i(x_{-i}) = \sup_{d_i \in [0,1]} u_i(d_i, x_{-i})$  is upper semicontinuous at  $x_{-i} = 0$ . But from a),  $V_i(\cdot)$  is also lower semicontinuous, as the supremum of a family of lower semicontinuous mappings. This finally proves that  $V_i$  is continuous.

d) Suppose for example  $i = 1$ . We use the following Claim:

**Claim 1** *If  $l$  is a quasiconcave function from  $[0, 1]$  to  $\mathbf{R}$  and  $l(y) < l(x)$  for some  $x < y$  in  $[0, 1]$  then for every  $z \in [y, 1]$ ,  $l(z) \leq l(y)$ . The proof is straightforward: indeed, for every  $z = \lambda y + (1 - \lambda)1$ , where  $\lambda \in [0, 1]$ , the quasiconcavity of  $l$  gives  $l(y) \geq \min\{l(x), l(z)\}$ , because  $y \in [x, z]$ . Since  $l(y) < l(x)$ , we obtain  $l(y) \geq l(z)$ .*

*Proof of d) i)* The inequality  $f_1(0, 0) > g_1(0, 0)$  implies  $f_1(0, x_2) > g_1(x_2, x_2)$  for  $x_2 \geq 0$  small enough. Applying Claim 1 to  $u_1(\cdot, x_2)$ , we obtain:

$$\sup_{d_1 \in [x_2, 1]} g_1(d_1, x_2) = g_1(x_2, x_2) \quad (10)$$

Let  $\varepsilon > 0$ . The continuity of  $f_1$  leads to

$$\sup_{d_1 \in [0, x_2]} f_1(d_1, x_2) \leq f_1(0, x_2) + \varepsilon \quad (11)$$

for  $x_2 > 0$  small enough. Hence, from  $h_1(x_1, x_1) \in \text{co}\{f_1(x_1, x_1), g_1(x_1, x_1)\}$ , we obtain

$$\sup_{d_1 \in [0, 1]} u_1(d_1, x_2) = \max\left\{ \sup_{d_1 \in [0, x_2]} f_1(d_1, x_2), h_1(x_2, x_2), \sup_{d_1 \in [x_2, 1]} g_1(d_1, x_2) \right\} \leq f_1(0, x_2) + \varepsilon = u_1(0, x_2) + \varepsilon \quad (12)$$

for  $x_2 > 0$  small enough.

*Proof of d) ii)* From the continuity of  $g_1$ , passing to the limit  $x_2 \rightarrow 0$  in Equation 10, we obtain  $\sup_{d_1 \in [0, 1]} g_1(d_1, 0) = g_1(0, 0)$ . Since  $h_1(0, 0) \in [g_1(0, 0), f_1(0, 0)]$ , this gives

$$\sup_{d_1 \in [0, 1]} u_1(d_1, 0) = \max\{h_1(0, 0), \sup_{d_1 \in [0, 1]} g_1(d_1, 0)\} \leq h_1(0, 0) = u_1(0, 0),$$

which proves (ii).

**Proof of Proposition 6.** Let  $(x_1, x_2, v_1, v_2) \in \bar{\Gamma}$  be a Reny equilibrium of  $G$ , and prove it to be an approximated equilibrium. From the definition of a Reny equilibrium and from point a) of Lemma 18, we get:

$$V_i(x_{-i}) = \sup_{d_i \in [0, 1]} u_i(d_i, x_{-i}) \leq v_i, \quad i = 1, 2. \quad (13)$$

*Step 1.* Assume  $x_1 \neq x_2$ . In this case,  $u_i$  is continuous at  $x = (x_1, x_2)$ ,  $v_i = u_i(x)$ , and Inequation 13 means that  $x$  is a Nash equilibrium.

*Step 2.* Assume  $x_1 = x_2 \in ]0, 1[$ . From b) of Lemma 18, the function  $V_i(x_{-i}) = \sup_{d_i \in [0, 1]} u_i(d_i, x_{-i})$  is continuous at  $x_1 = x_2$  for every  $i \in \{1, 2\}$ . Consequently, from Inequation 13 and since  $(x_1, x_1, v_1, v_2)$  is in the closure of the graph of the payoff functions, for every  $\varepsilon > 0$ , there exists  $(x'_1, x'_2, u_1(x'_1, x'_2), u_2(x'_1, x'_2))$

close enough to  $(x_1, x_1, v_1, v_2)$  such that:

$$V_i(x'_{-i}) = \sup_{d_i \in [0,1]} u_i(d_i, x'_{-i}) \leq u_i(x'_1, x'_2) + \varepsilon, \quad i = 1, 2. \quad (14)$$

Therefore,  $(x_1, x_1)$  is an approximated equilibrium.

*Step 3.* To finish, suppose  $(x_1, x_2) \in \{(0, 0), (1, 1)\}$ . We consider only the case  $(x_1, x_2) = (0, 0)$ , the case  $(x_1, x_2) = (1, 1)$  being similar. Depending on the local configuration of the payoff functions around  $(0, 0)$ , we should examine 9 cases:  $f_i(0, 0) < g_i(0, 0)$ ,  $f_i(0, 0) = g_i(0, 0)$  and  $f_i(0, 0) > g_i(0, 0)$ , for every  $i = 1, 2$ . For symmetry reason (permuting players if necessary), only the 3 following cases have to be considered:

**First Case.**  $f_i(0, 0) \leq g_i(0, 0)$  for every  $i = 1, 2$ . From c) of Lemma 18,  $V_i(x_{-i})$  is continuous at  $x_{-i} = 0$  for every player  $i$ . Thus, we are exactly in the situation of Step 2, and  $(0, 0)$  is an approximated equilibrium.

**Second Case.**  $f_i(0, 0) > g_i(0, 0)$  for every  $i = 1, 2$ . From d) of Lemma 18, this implies that  $(0, 0)$  is a Nash equilibrium.

**Third Case.**  $f_1(0, 0) > g_1(0, 0)$  and  $f_2(0, 0) \leq g_2(0, 0)$ . Since  $(x_1, x_1, v_1, v_2)$  is in the closure of the graph of the payoff functions,  $v_2 = \lim_{n \rightarrow +\infty} u_2(x^n)$  for some sequence of strategy profiles  $x^n$  converging to  $(0, 0)$ . From  $h_2(x_i, x_i) \in \text{co}\{f_2(x_i, x_i), g_2(x_i, x_i)\}$ , we get  $u_2(x^n) \leq \max\{f_2(x^n), g_2(x^n)\}$ . Thus, from the continuity of  $f_2$  and  $g_2$ , we obtain

$$v_2 \leq g_2(0, 0). \quad (15)$$

Thus, taking  $\varepsilon > 0$ , and from Inequation 13 for  $i = 2$ ,

$$\sup_{d_2 \in [0,1]} u_2(0, d_2) \leq v_2 \leq g_2(0, 0) \leq g_2(0, x_2) + \varepsilon = u_2(0, x_2) + \varepsilon. \quad (16)$$

for  $x_2 > 0$  small enough. But from Lemma 18 (d) i),  $\sup_{d_1 \in [0,1]} u_1(d_1, x_2) \leq u_1(0, x_2) + \varepsilon$  for  $x_2 > 0$  small enough, i.e.  $(0, x_2)$  is an  $\varepsilon$ -equilibrium.

## 8.2 Proof of Theorem 6

Let  $(m, v)$  be a finite mixed deviation equilibrium. First let us prove that it is a Reny equilibrium of the mixed extension of the game: for every deviation  $d \in M$ , and any neighborhood  $V$  of  $(m, v)$ , the definition of a finite mixed deviation equilibrium gives  $m^V \in M$  such that: (1) for every  $i$ ,  $u_i(d_i, m^V_{-i}) \leq u_i(m^V)$ ; (2)  $(m^V, u(m^V)) \in V$ . Shrinking  $V$  to  $(m, v)$  implies that  $\underline{u}_i(d_i, m_{-i}) \leq v_i$  for every  $d \in M$ , i.e.  $(m, v)$  is a Reny equilibrium of the mixed extension of  $G$ .

Now, let us prove that  $(m, v)$  induces a solution à la Simon-Zame. Since  $M$  is metric, there exists a countable decreasing basis of neighborhoods  $V^n$  of  $(m, v)$  in  $\bar{\Gamma}$ . Consider a sequence  $D^n = \prod_{i \in I} D_i^n$  converging to  $X$  for the Hausdorff distance. By definition of a finite mixed deviation equilibrium, for every integer  $n$ , there exists a finite set  $D^n = \prod_{i \in I} D_i^n$  of  $M$  containing  $D^n$ , and a probability  $m^n$

which is a Nash of the game restricted to  $D'^n$ , and such that  $(m^n, u(m^n)) \in V^n$ . Recall that Simon and Zame's [32] existence proof consists in approximating the game by a finite one in pure-strategies (here  $D^n$ ), and considering a weak limit of a sequence  $(m^n)$  of Nash equilibria of this approximation. We cannot apply Simon and Zame's proof directly to the Nash equilibria  $m^n$  of the finite games  $D'^n$ , because  $D^n$  is a mixed-strategy game. But  $D'^n \supset D^n$ : thus, no player  $i$  has a deviation in  $D'_i^n$  against  $m^n$ , and we shall prove that this property is sufficient to adapt Simon-Zame's proof. Remark that the sequence  $(m^n)$  converges (strongly and weakly) to  $m$ . Let  $E$  be the space of  $\mathbb{R}^N$ -valued vector measure on  $X$ , endowed with the weak\* topology. Consider the sequence  $(u.m^n)_{n \in \mathbb{N}}$  of the compact space  $E$  (here,  $u.m^n$  denotes the  $\mathbb{R}^N$ -valued measure on  $X$  defined by  $u.m^n(F) = \int_F u \, dm^n$  for every Borelian set  $F$  of  $X$ ). Without any loss of generality, up to a subsequence, this sequence converges to some measure  $\nu$ . From Lemma 2, p.867 (Simon-Zame [32]), there exists a Borel measurable selection  $q$  of  $Q$ , the multivalued function from  $X$  to  $\mathbb{R}^N$ , defined by  $Q(x) = \text{co } \bar{\Gamma}_x$ , such that the  $\nu = q.m$  (remark that the proof of this lemma does not use the support of  $m^n$ , but only the fact that  $u$  is a selection of  $Q$ ). Thus,  $q$  is a sharing rule (in the sense of Simon-Zame) of the game  $G$ . Define, for every player  $i$ ,  $H_i = \{x \in X_i : \int q_i d(\delta_x \times m_{-i}) > \int q_i d(m_i \times m_{-i})\}$ . We prove  $m_i(H_i) = 0$ : otherwise, consider  $K \subset H_i \subset U$ , where  $K$  is compact,  $U$  open,  $m_i(U - K) < \varepsilon$  with  $\varepsilon > 0$ , and with  $m_i(K) > 0$ . Let  $f : X_i \rightarrow [0, 1]$  be a continuous function which is identically equal to 1 on  $K$  and 0 on the complement of  $U$ . Consider the strategy  $\beta_i^n = \frac{f m_i^n}{\int f d m_i^n}$ : it is a better response to  $m_{-i}^n$  for  $n$  large enough and  $\varepsilon > 0$  small enough, which contradicts the fact that  $m^n$  is a Nash of the game restricted to  $D'^n$ . From Simon Zame ([32], Step 5 and Step 6), there exists a modification  $\tilde{q}$  of  $q$ , such that  $q = \tilde{q}$  except on a set of  $m$ -measure 0, such that  $m$  is a Nash equilibrium of the game  $\tilde{G} = ((X_i)_{i \in N}, (\tilde{q}_i)_{i \in N})$ , and  $\tilde{q}(m) = q(m)$ . More precisely, take  $\tilde{p}^i$  a Borel measurable selection of  $Q$  which minimizes the  $i$ -th component of  $Q$ , define  $T = \{x \in X : x_i \in H_i \text{ for at least two indices } i \in N\}$ , define  $\tilde{q}(x) = \tilde{p}^i(x)$  if  $x \in H_i \times X_{-i}$  but  $x \notin T$ , and  $\tilde{q}(x) = q(x)$  otherwise. To prove  $m$  is a Nash of  $\tilde{G}$ , assume that some player  $i$  has a better pure response than  $m_i$ , denoted  $\delta_x$ , to  $m_{-i}$ . Then the case  $x \notin H_i$  yields an easy contradiction. For the second case, simply consider a sequence  $x^n$  converging to  $x$  such that  $x^n \in D'_i^n$  (here, we use that  $D^n = \prod_{i \in I} D'_i^n$  converges to  $X$  for the Hausdorff distance): an easy limit argument proves that  $\delta_{x^n}$  is a better response than  $m_i^n$  to  $m_{-i}^n$  for  $n$  large enough, a contradiction with the choice of  $m^n$ .

### 8.3 Proof of Proposition 12

The proof is done by constructing a strategic approximation. Call  $x \in [0, 1]$  a right local equilibrium if  $h_i(x, x) > g_i(x, x)$  for every  $i = 1, 2$  and a left local equilibrium if  $h_i(x, x) > f_i(x, x)$  for every  $i = 1, 2$ . Thus, if players are supposed to play  $(x, x)$  and if  $x$  is a right local equilibrium, no player has an interest to deviate to some strategy in some right neighborhood of  $x$  (but he may have a profitable deviation outside that neighborhood) and similarly for left equilibria.

Let  $x_0$  be the largest element in  $[0, 1]$  such that all  $x < x_0$  are right local equilibria and  $y_0$  be the smallest element in  $[0, 1]$  such that all  $y > y_0$  are left local equilibria. Observe that  $x_0$  may be 0 and  $y_0$  could be 1.

By continuity of  $f$ ,  $g$  and  $h$ , if  $x_0 < 1$  then  $h_i(x_0, x_0) \leq g_i(x_0, x_0)$  for some  $i \in \{0, 1\}$  and similarly, if  $y_0 > 0$  then  $h_i(y_0, y_0) \leq f_i(y_0, y_0)$  for some  $i \in \{0, 1\}$ . We now examine three different cases:

**First case.**  $x_0 > y_0$ . Let  $D$  be some finite discretization of  $[0, 1]$  with a mesh smaller than  $\eta > 0$  so that payoff functions  $f$  and  $g$  do not change by more than  $\frac{\varepsilon}{2}$  if a player moves by no more than  $\eta$  and such that if  $x < x_0$  is in  $D$ , then  $h_i(x, x) > g_i(y, x)$  for all  $x < y < x + \eta$  and if  $x > y_0$  is in  $D$ , then  $h_i(x, x) > f_i(y, x)$  for all  $x > y > x + \eta$ . Without any loss of generality, we can assume that 0 and 1 belong to  $D$ .

Let us show that for any mixed strategy  $\sigma_j$  of player  $j$  that belongs to  $D$ , there is an  $\varepsilon$ -best reply of player  $i$  in the entire game  $G$  that belongs to  $D$ . This will imply that any mixed equilibrium of the game restricted to  $D$  is an  $\varepsilon$ -equilibrium of the full game, so that  $D$  is a strategic approximation that leads to approximated equilibria (i.e., the game admits an approximated strategic approximation).

Let  $y \in [0, 1]$  be some  $\varepsilon/2$ -best reply to  $\sigma_j$  of player  $i$  which is not in  $D$  (if such strategy does not exist, this is finished). Then either  $y < x_0$  or  $y > y_0$ . In the first case, let  $z$  be the highest element in  $D$  smaller than  $y$ , so that  $h_i(z, z) > f_i(y, z)$  by assumption of the discretization and since  $z$  is a right equilibrium. Since player  $j$  plays a probability distribution supported on  $D$ , moving from  $y$  to  $z$  for player  $i$  induces for him a higher payoff from the event associated to player  $j$  playing  $z$  and at most a change of  $\frac{\varepsilon}{2}$  on the events where player  $j$  is playing a strategy in  $D$  different from  $z$ . Thus,  $z$  is an  $\varepsilon$ -best reply for player  $i$ . A similar argument applies to  $y > y_0$  (use the left equilibrium property). Remark also that the argument is the same for both players.

**Second case.**  $x_0 < y_0$ , which implies that  $h_k(x_0) \leq g_k(x_0, x_0)$  and  $h_l(y_0) \leq f_l(y_0, y_0)$  for some  $k \in \{1, 2\}$  and  $l \in \{1, 2\}$ . By continuity, we get  $h_k(x_0) < g_k(x, x_0) + \frac{\varepsilon}{4}$  for every  $x \in ]x_0, x_0 + \eta[$  and  $h_l(y_0) < f_l(y, y_0) + \frac{\varepsilon}{4}$  for every  $y \in ]y_0 - \eta, y_0[$ .

Thus, there are four cases to check, depending on the values of  $k$  and  $l$ . Let us solve explicitly the case  $k = 1$  and  $l = 2$ . The same idea of construction could be done in the other cases, with a small adaptation in the strategic approximation explained below.

Fix  $\varepsilon > 0$  and let  $x_0 = t_0 < s_0 < t_1, \dots < s_{K-1} < t_K = y_0$  be a discretization of  $[x_0, y_0]$  with a mesh smaller than some  $\eta > 0$  so that payoff functions  $f$  and  $g$  do not change by more than  $\varepsilon/4$  if the pure strategy moves by no more than  $\eta$ . As in the first case, let  $D$  be a finite discretization of  $[0, x_0 \cup ]y_0, 1]$  with a mesh smaller than  $\eta > 0$  so that payoff functions  $f$  and  $g$  do not change by more than  $\frac{\varepsilon}{2}$  if the pure strategy moves by no more than  $\eta$  and such that if  $x < x_0$  is in  $D$ , then  $h_i(x, x) > g_i(y, x)$  for all  $x < y < x + \eta$  and if  $x > y_0$  is in  $D$ , then  $h_i(x, x) > f_i(y, x)$  for all  $x > y > x + \eta$ . Assume 0 and 1 belongs to  $D$ .

In the strategic approximation we consider, player 1 is restricted to play in  $D$  or uniformly on one of the intervals  $[t_k, s_k]$ ,  $k = 0, \dots, K - 1$ , or to choose  $t_K = y_0$ . Player 2 is restricted to play in  $D$  or uniformly on one of the intervals  $[s_k, t_{k+1}]$ ,  $k = 0, \dots, K - 1$ , or to choose  $t_0 = x_0$ . Observe that the intervals where players are uniformly mixing are disjoint and alternate.

Let  $\sigma$  be some strategy of player 2 in the restricted game. Let us show that player 1 has an  $\varepsilon$ -best response against  $\sigma$  in the full game  $G$  that belongs to his authorized set of strategies. Let  $y$  be some  $\varepsilon/4$  pure best response of player 1 in  $G$ , which is not in the discretization  $D$ . Several subcases have to be examined:

**First subcase.** If  $y < x_0$  or  $y > y_0$ , we proceed as in the first case to construct an  $\varepsilon$ -best reply in  $D$ .

**Second subcase.** If  $y$  is in some interval  $]s_k, t_{k+1}[$  of player 2 ( $k \in \{0, 1, \dots, K - 1\}$ ), and if

player 2 is choosing that interval with positive probability, the payoff of 1 coming from that interval is, up to  $\varepsilon/4$ , a convex combination of his payoff if he chooses  $t_{k+1}$  and his payoff if he chooses  $s_k$ : more precisely, if  $\eta$  is a uniform strategy on  $[s_k, t_{k+1}]$ ,  $u_1(y, \eta) = \int_{s_k}^y g_1(y, \alpha) d\alpha + \int_y^{t_{k+1}} f_1(y, \alpha) d\alpha = \int_{s_k}^y g_1(y, \alpha) d\alpha - \frac{y-s_k}{t_{k+1}-s_k} \int_{s_k}^{t_{k+1}} g_1(y, \alpha) d\alpha + \int_y^{t_{k+1}} f_1(y, \alpha) d\alpha - \frac{t_{k+1}-y}{t_{k+1}-s_k} \int_{s_k}^{t_{k+1}} f_1(y, \alpha) d\alpha + c$  where  $c = \frac{y-s_k}{t_{k+1}-s_k} \int_{s_k}^{t_{k+1}} g_1(y, \alpha) d\alpha + \frac{t_{k+1}-y}{t_{k+1}-s_k} \int_{s_k}^{t_{k+1}} f_1(y, \alpha) d\alpha$ , i.e.  $c$  is a convex combination of player 1's payoff if he chooses  $t_k$  and his payoff if he chooses  $s_k$  (player 2 playing  $\eta$ .) But

$$\int_{s_k}^y g_1(y, \alpha) d\alpha - \frac{y-s_k}{t_{k+1}-s_k} \int_{s_k}^{t_{k+1}} g_1(y, \alpha) d\alpha = (y-s_k)(g_1(y, \alpha_1) - g_1(y, \alpha'_1))$$

and

$$\int_y^{t_{k+1}} f_1(y, \alpha) d\alpha - \frac{t_{k+1}-y}{t_{k+1}-s_k} \int_{s_k}^{t_{k+1}} f_1(y, \alpha) d\alpha = (t_{k+1}-y)(f_1(y, \alpha_2) - f_1(y, \alpha'_2))$$

for some  $\alpha_1, \alpha'_1 \in [s_k, y]$  and  $\alpha_2, \alpha'_2 \in [y, t_{k+1}]$ . Thus, from the choice of the discretization, we obtain  $|u_1(y, \eta) - c| \leq \frac{\varepsilon}{4}$ .

Now, the payoff of player 1 coming from Player 2 playing in the other intervals or in  $D$  changes by no more than  $\varepsilon/4$  when he moves in the interval  $[t_k, s_{k+1}]$ . Consequently, if player 1 has a  $\frac{3}{4}\varepsilon$ -best response at the extreme points  $t_k$  or  $s_{k+1}$  of the interval. If that strategy is  $y_0$ , this is fine since it is authorized for player 1. If not, then as seen, we can restrict the analysis to  $\frac{3}{4}\varepsilon$ -best responses  $z$  that belongs to some interval  $[t_k, s_k]$ , which is the next case:

**Third subcase.** Let  $z \in [t_k, s_k]$  being a  $\frac{3}{4}\varepsilon$ -best response, for some  $k \in \{0, 1, \dots, K-1\}$ . If  $k > 0$ , by assumption, there is zero probability that player 2 stops in that interval and so player 1's payoff does not move by more than  $\varepsilon/4$  if he plays uniformly in  $[t_k, s_k]$  (which is authorized for player 1) instead of playing  $z$ . This gives a  $\varepsilon$ -best response. If  $k = 0$ , if player 2 is playing  $x_0$  with positive probability and player 1 is playing  $z = x_0$ , then player 1 does not lose more than  $\varepsilon/4$  by playing slightly more than  $x_0$  instead of  $x_0$  (since  $h_1(x_0) < g_1(x, x_0) + \frac{\varepsilon}{4}$  for every  $x \in ]x_0, x_0 + \eta[$ ). Thus, we still have the case where  $z$  belongs to the interval  $]t_0, s_0[$ . But, again, since his payoff moves continuously in that interval, playing uniformly in it is an  $\varepsilon$ -best response.

The proof for player 2 is similar (we use the fact that  $h_2(y_0) < f_2(y, y_0) + \frac{\varepsilon}{4}$  for every  $y \in ]y_0 - \eta, y_0[$ ).

The three remaining cases for  $k$  and  $l$  are solved similarly, by a judicious choice of who of the two players is allowed to stop at  $x_0$  and  $y_0$ : if  $k = 2$  and  $l = 1$ , then player 1 can stop at  $x_0$  and player 2 at  $y_0$ ; if  $k = 2$  and  $l = 2$ , (only) player 1 is allowed to stop at both  $x_0$  and  $y_0$ ; if  $k = 1$  and  $l = 1$ , only player 2 is allowed to stop at both points. If some player can stop at  $x_0$  then it is the other player who is authorized to stop uniformly in the small interval of the discretization just after  $x_0$ , and the intervals in which players can stop uniformly alternate until the point  $y_0$ , and the last interval belongs to the player who is not allowed to stop at  $y_0$ .

**Third case.**  $x_0 = y_0$ , implying  $h_k(x_0) < g_k(x, x_0) + \frac{\varepsilon}{4}$  for  $x \in ]x_0, x_0 + \eta[$  and  $h_l(x_0) < f_l(x, x_0) + \frac{\varepsilon}{4}$  for  $x \in ]x_0 - \eta, x_0[$  for some  $k \in \{1, 2\}$  and  $l \in \{1, 2\}$  (if  $x_0$  is 0 or 1, then only one of the inequalities holds). Suppose for example that  $h_1(x_0) < g_1(x, x_0) + \frac{\varepsilon}{4}$  for  $x \in ]x_0, x_0 + \eta[$ . Let  $D_1 = \{0 = t_0 < \dots < t_K\}$  be a discretization on the left of  $x_0$ , not including  $x_0$ , and empty if  $x_0 = 0$ ; let  $D_2 = \{s_0 < \dots < s_K = 1\}$  be a discretization on the right of  $x_0$ , not including  $x_0$ , and empty if  $y_0 = 1$ . Again, without any loss of gener-



ality, assume that the mesh of the discretizations is smaller than  $\eta > 0$ , so that payoff functions  $f$  and  $g$  do not change by more than  $\frac{\varepsilon}{2}$  if a player moves by no more than  $\eta$ . Consider a strategic approximation where Player 2 is allowed to play in  $D_1 \cup D_2 \cup \{x_0\}$  and player 1 to play in  $D_1 \cup D_2$  or to mix uniformly in the length  $[x_0, s_0]$ . Let  $y \in [0, 1]$  be some  $\varepsilon/2$ -best reply of player 1 to some mixed strategy of player 2 which is not in  $D$  (if such strategy does not exist, this is finished). If  $y < x_0$ , moving from  $y$  to the highest element in  $D_1$  smaller than  $y$  gives an  $\varepsilon$ -best reply for player 1. If  $y > x_0$ , moving from  $y$  to the smallest element in  $D_1$  larger than  $y$  gives an  $\varepsilon$ -best reply for player 1. Last, if  $y = x_0$ , playing uniformly in  $[x_0, y_0]$  instead of playing  $x_0$  is an  $\varepsilon$ -best reply for player 1, because of  $h_1(x_0) < g_1(x, x_0) + \frac{\varepsilon}{4}$  for  $x \in ]x_0, x_0 + \eta[$ . Similarly, let  $z \in [0, 1]$  be some  $\varepsilon/2$ -best reply of player 2 to some mixed strategy of player 1. If  $z < x_0$  or  $z > x_0$ , then player 2 has an  $\varepsilon$ -best reply in  $D_1 \cup D_2 \cup \{x_0\}$ , moving slightly above or below (this is similar to player 1). This finishes the case  $k = 1$ , and permuting player 1 and 2, we get similarly the case  $k = 2$ .

## 8.4 Proof of Proposition 13

The proof is similar to Case 2 in the complete information case, and use the construction of a strategic approximation. There are four possibilities for i) and ii). Suppose i) is satisfied for player 1 and ii) for 2. The strategic approximation should be adapted in the other 3 cases, as in the proof of Proposition 12.

Take the following discretization of  $[0, 1]$ :  $0 = s_0 < t_0 < s_1 < t_1 < \dots < t_K < s_{K+1} = 1$ . The mesh is supposed smaller than some  $\eta$  where  $f$  and  $g$  do not move by more than  $\varepsilon/4$  when bids move by less than  $\eta$  and such that for every  $t \in T$ ,  $h_1(t_1, t_2, 0) < g_1(t_1, t_2, x, 0) + \frac{\varepsilon}{4}$  when  $0 < x < \eta$ .

In the strategic approximation, player 1 is restricted to play uniformly on one of the intervals  $[s_k, t_k]$ ,  $k = 0, \dots, K$ , or to choose  $x = 1$ . Player 2 is restricted to play uniformly on one of the intervals  $[t_k, s_{k+1}]$ ,  $k = 0, \dots, K$ , or to choose  $x = 0$ .

This leads to a game where each player has  $K + 1$  possible mixed actions and one pure action. Observe that the intervals where players are mixing are disjoint and alternate (player 1 can stop uniformly in the first interval, player 2 in the second, player 1 in the third, etc.).

Let  $\sigma$  be some mixed strategy profile of player 2 in the finite game. Show that any type  $t_1$  has an  $\varepsilon$ -best response against  $\sigma$  in the full game that belongs to his set of authorized strategies.

Let  $x$  be some  $\varepsilon/4$  pure best response of some type  $t_1$  of player 1. If that strategy is in the interval  $]t_k, s_{k+1}[$  of player 2, and if some type of player 2 is choosing that interval with positive probability, the payoff of  $t_1$  coming from that interval is, up to  $\varepsilon/4$ , a convex combination of his payoff if he chooses  $t_k$  and his payoff if he chooses  $s_{k+1}$  (recall that payoff functions are continuous and that all types of player 2 are restricted to the uniform distribution on that interval). The payoff of type  $t_1$  coming from the other intervals moves by no more than  $\varepsilon/4$  when he moves in the interval  $[t_k, s_{k+1}]$ . Consequently, if type  $t_1$  has an  $\varepsilon/4$ -best response in  $]t_k, s_{k+1}[$ , he has a  $\frac{3}{4}\varepsilon$  best response at the extreme points of the interval. If that strategy is 1, this is fine since that strategy is authorized for player 1. If not, then we can without loss of generality restrict the analysis to  $\frac{3}{4}\varepsilon$ -best responses that lies in some interval  $[s_k, t_k]$  (of player 1). If  $k > 0$ , by assumption, there is zero probability that player 2 stops in that interval and so player 1's payoff does not move by more than  $\varepsilon/4$ : playing uniformly in that interval is an  $\varepsilon$ -best response. If  $x = 0$  and if some type of player 2 is playing 0 with positive probability, player 1 does not lose so much by playing slightly more than 0 instead of 0. There still remains the case where  $x$  belongs to the interval

$]s_0, t_0[$ . But, again, since his payoff moves continuously in the interval, playing uniformly in it is an  $\varepsilon$ -best response. The proof for player 2 is the same, except that we need to use assumption ii) to conclude that player 2 can always have a best reply different from 1.

## 8.5 Proof of Proposition 15

This existence result is an adaptation of the proof of Proposition 6. First of all, we adapt Lemma 18 as follows:

**Lemma 19** *Let  $G = ((f_i, g_i, h_i)_{i=1,2})$  be a diagonal game such that  $f_i, g_i$  and  $h_i$  are continuous. Then:*

a)  $\sup_{d_i \in [0,1]} u_i(d_i, x_{-i}) = \sup_{d_i \in [0,1]} \underline{u}_i(d_i, x_{-i})$ .

b) For every  $x_{-i} \in ]0, 1[$ , the function  $V_i(x_{-i}) = \sup_{d_i \in [0,1]} u_i(d_i, x_{-i})$  is continuous at  $x_{-i}$ .

c) For every  $i = 1, 2$ , if  $f_i(0, 0) \leq g_i(0, 0)$  then  $V_i(x_{-i})$  is continuous at  $x_{-i} = 0$ .

d) For every  $i = 1, 2$ , if  $f_i(0, 0) > g_i(0, 0)$  then:

(i) either  $h_i(0, 0) \leq f_i(0, 0)$  and for every  $\varepsilon > 0$ ,  $\sup_{d_i \in [0,1]} u_i(d_i, x_{-i}) \leq u_i(0, x_{-i}) + \varepsilon$  for  $x_{-i} \geq 0$  small enough ( $\varepsilon$  can be taken equal to 0 if  $x_{-i} = 0$ ).

(ii) or  $h_i(0, 0) > f_i(0, 0)$ , and  $\sup_{d_i \in [0,1]} u_i(d_i, x_{-i}) = u_i(x_{-i}, x_{-i})$  for  $x_{-i} \geq 0$  small enough.

Thus, in both cases (i) and (ii),  $\sup_{d_i \in [0,1]} u_i(d_i, 0) = u_i(0, 0)$ .

**Proof of Lemma 19.** a) We can simply adapt the point a) of Lemma 18 to the following generalized notion of payoff security: the game  $G$  is said *generalized payoff secure at  $x$*  if for every  $\varepsilon > 0$  there exists a Kakutani's mappings from  $U$  (some neighborhood of  $x_{-i}$ ) to  $X_i$  such that  $u_i(d'_i, x'_{-i}) > u_i(x) - \varepsilon$  for every  $x'_{-i} \in U$  and every  $d'_i \in \Phi(x'_{-i})$ . Then  $G = ((f_i, g_i, h_i)_{i=1,2})$  is generalized payoff secure at every  $x \in X$ : if  $x$  is not on the diagonal, this is because  $u_i$  is continuous at such  $x$ , and if  $x = (x_i, x_i)$ , we can take  $\Phi(x_i) = x_i$ . This implies a).

b) Let  $x_{-i} \in ]0, 1[$ . The definition of  $u_i$  gives

$$V_i(x_{-i}) := \sup_{d_i \in [0,1]} u_i(d_i, x_{-i}) = \max\left\{ \sup_{d_i \in [0, x_{-i}]} f_i(d_i, x_{-i}), h_i(x_{-i}, x_{-i}), \sup_{d_i \in [x_{-i}, 1]} g_i(d_i, x_{-i}) \right\}. \quad (17)$$

Thus, from Berge Maximum Theorem (see [1]), the mapping  $\sup_{d_i \in [0,1]} u_i(d_i, x_{-i})$  is continuous at every  $x_{-i} \in ]0, 1[$ .

c) Suppose  $f_i(0, 0) \leq g_i(0, 0)$  for some  $i \in \{1, 2\}$ . If  $h_i(0, 0) \leq g_i(0, 0)$ , then the continuity of  $V_i$  at  $(0, 0)$  is obtained as in the proof of c) of Lemma 18 (since Inequalities 4 and 5 are still true, from the continuity of  $f_i, g_i$  and  $h_i$ ). If  $h_i(0, 0) > g_i(0, 0)$ , then  $V_i(x_i) = h_i(x_i, x_i)$  on some neighborhood of 0, which proves the continuity of  $V_i$  at 0.

d) i) Similar to the proof of d) i) in Lemma 18. Indeed, in the proof of Equation 12, we only need  $h_1(x_2, x_2) < f_1(0, x_2) + \varepsilon$  for  $x_2 > 0$  small enough, which is true by continuity.

ii) If  $h_i(0, 0) > f_i(0, 0)$  then by continuity  $V_i(x_i) = h_i(x_i, x_i)$  on some neighborhood of 0.

**Proof of Proposition 19.** let  $(x_1, x_2, v_1, v_2) \in \bar{\Gamma}$  be a BS equilibrium of  $G$ , and prove it to be an approximated equilibrium. From the definition of a Reny equilibrium and from point a) of Lemma 19, we get

$$V_i(x_{-i}) = \sup_{d_i \in [0,1]} u_i(d_i, x_{-i}) \leq v_i, \quad i = 1, 2. \quad (18)$$

Similarly to the proof of Proposition 6, we need to consider only the cases where  $(x_1, x_2) = (0, 0)$  and the case  $f_1(0, 0) > g_1(0, 0)$  and  $f_2(0, 0) \leq g_2(0, 0)$ , the other cases being similar to those of the proof of Proposition 6 (up to a permutation of players). Remark that  $f_1(0, 0) > g_1(0, 0)$  implies

$$\sup_{d_1 \in [0,1]} u_1(d_1, 0) = u_1(0, 0) \quad (19)$$

from d) of Lemma 19, i.e. 0 is a best response of player 1 against  $x_2 = 0$ .

Now, we examine 2 different subcases, depending on  $h_2(0, 0)$ :

**Subcase 1.** Suppose  $h_2(0, 0) \geq g_2(0, 0)$ . Since  $(0, 0, v_1, v_2)$  is in the closure of the graph of the payoff functions,  $v_2 = \lim_{n \rightarrow +\infty} u_2(x^n)$  for some sequence of strategy profiles  $x^n$  converging to  $(0, 0)$ . Thus, from  $h_2(0, 0) \geq g_2(0, 0) \geq f_2(0, 0)$ , and by continuity, we get  $v_2 \leq u_2(0, 0) = h_2(0, 0)$ . From Inequations 18, this implies that 0 is a best response of player 2 against  $x_1 = 0$ , thus  $(0, 0)$  is a Nash equilibrium.

**Subcase 2.** Now, suppose  $h_2(0, 0) < g_2(0, 0)$ . First, assume that  $h_1(0, 0) \leq f_1(0, 0)$ . We can mimic the proof of Proposition 6, Case 3 (since  $h_i(x_i, x_i) \in \text{co}\{f_i(x_i, x_i), g_i(x_i, x_i)\}$  is only used to prove Inequation 9 (i.e.  $v_2 \leq g_2(0, 0)$ ), which can be proved here directly as in Subcase 1 above): this implies that  $(0, 0)$  is an approximated equilibrium. Second, assume that  $h_1(0, 0) > f_1(0, 0)$ . Equation 18 implies that  $h_1(0, 0) = u_1(0, 0) \leq \sup_{d_i \in [0,1]} u_i(d_i, x_{-i}) \leq v_i$ . Again, since  $(0, 0, v_1, v_2)$  is in the closure of the graph of the payoff functions,  $v_1 = \lim_{n \rightarrow +\infty} u_1(x^n)$  for some sequence of strategy profiles  $x^n$  converging to  $(0, 0)$ . Thus, from  $h_1(0, 0) > f_1(0, 0) > g_1(0, 0)$ , and by continuity,  $x^n$  is on the diagonal for  $n$  large enough. Thus  $v_2 = h_2(0, 0) = u_2(0, 0)$ , and  $(0, 0)$  is a Nash equilibrium.

## 8.6 Proof of Theorem 7

The proof of Theorem 7 will be based on the selection lemma below. Given  $y = (y_i)_{i \in N} \in \mathbb{R}^N$  and  $y' = (y'_i)_{i \in N} \in \mathbb{R}^N$ , define  $y \vee y' = (\max\{y_i, y'_i\})_{i \in N} \in \mathbb{R}^N$ . A multivalued mapping  $\Psi$  from  $X$  to  $\mathbb{R}^N$  is called  $\vee$ -stable if  $y \vee y' \in \Psi(x)$  whenever  $x \in X$  and  $(y, y') \in \Psi(x) \times \Psi(x)$ .

**Lemma 20** *Let  $X$  be a compact subset of a topological vector space. Let  $\Psi$  be a  $\vee$ -stable multivalued mapping from  $X$  to  $\mathbb{R}^N$  such that for every  $x \in \mathbb{R}^N$ , there exists a neighborhood  $V$  of  $x$  such that  $\cap_{x' \in V} \Psi(x') \neq \emptyset$ . Then  $\Psi$  admits a selection  $\psi = (\psi_i)_{i \in N}$  such that for every  $i \in N$  and every  $\alpha \in \mathbb{R}^N$ , the set  $\{x \in X : \forall i \in N, \psi_i(x) \leq \alpha_i\}$  is open in  $X$ .*

**Proof.** For every  $x \in X$ , let  $V(x)$  be a compact<sup>13</sup> neighborhood of  $x$  such that  $\cap_{x' \in V(x)} \Psi(x') \neq \emptyset$ , and choose  $y(x) \in \cap_{x' \in V(x)} \Psi(x')$ . Since  $X$  is compact, there exist some compact neighborhoods

<sup>13</sup> Without any loss of generality, since  $X$  admits a compact basis of neighborhoods at every  $x \in X$ , taking a smaller neighborhood if necessary, we can assume  $V(x)$  compact.

$V(x_1), \dots, V(x_n)$  of  $x_1, \dots, x_n$ , whose interiors cover  $X$ . For every  $x \in X$ , define

$$\psi(x) = \vee_{k:x \in V(x_k)} y(x_k). \quad (20)$$

Since  $\Psi$  is  $\vee$ -stable, the mapping  $\psi : X \rightarrow \mathbb{R}^N$  is a selection of  $\Psi$ . Now, we claim that for every  $i \in N$  and every  $\alpha \in \mathbb{R}^N$ , the set

$$Y := \{x \in X : \forall i \in N, \psi_i(x) \leq \alpha_i\} \quad (21)$$

is an open subset of  $X$ . For every  $\bar{x} \in Y$ , it suffices to prove that

$$V := (\cup_{k:\bar{x} \in V(x_k)} V(x_k)) \cap (\cap_{k':\bar{x} \notin V(x_{k'})} {}^c V(x_{k'})) \quad (22)$$

is a neighborhood of  $\bar{x}$ , and is included in  $Y$ .

First,  $V$  is clearly a neighborhood of  $\bar{x}$  in  $X$ : indeed,  $\bar{x}$  belongs to the interior of some  $V(x_k)$  (since the interiors of  $V(x_1), \dots, V(x_n)$  cover  $X$ ), thus  $\cup_{k:\bar{x} \in V(x_k)} V(x_k)$  is a neighborhood of  $\bar{x}$ . Moreover,  $\cap_{k':\bar{x} \notin V(x_{k'})} {}^c V(x_{k'})$  is a finite intersection of (open) neighborhoods of  $\bar{x}$ .

Second, fix  $y \in V$ , and prove  $y \in Y$ , i.e.  $\psi_i(y) \leq \alpha_i$  for every  $i \in I$ . From the definition of  $\psi_i$  (Equation 20), this can be written equivalently: for every  $i \in I$ , for every  $k$  such that  $y \in V(x_k)$ ,  $y_i(x_k) \leq \alpha_i$ . To prove this last inequality, fix  $i \in I$  and  $k$  such that  $y \in V(x_k)$ : the definition of  $V$ ,  $\psi(\bar{x})$  and  $Y$  gives  $\bar{x} \in V(x_k)$ ,  $y_i(x_k) \leq \psi_i(\bar{x})$  and  $\psi_i(\bar{x}) \leq \alpha_i$ , so that  $y_i(x_k) \leq \alpha_i$ .

Now, we prove Theorem 7 by contradiction: assume  $G$  has no tight equilibrium. Define the multivalued mapping  $\Psi$  from  $X$  to  $\mathbb{R}^N$  as follows (where  $\mathcal{N}(x)$  denotes the set of open neighborhoods of  $x \in X$ ): for every strategy profile  $x \in X$ ,

$$\Psi(x) = \{\alpha \in \mathbb{R}^N : \exists V \in \mathcal{N}(x), \exists (\Phi_i)_{i \in N} \in \prod_{i \in N} W_V(x_{-i}) : (1) \inf_{(d'_i, x'_{-i}) \in Gr \Phi_i} u_i^{\Phi_i}(d'_i, x'_{-i}) \geq \alpha_i$$

$$(2) \forall z \in V, \exists i_0 : \alpha_{i_0} > u_{i_0}(z)\}.$$

We now check that Lemma 20 can be applied to  $\Psi$ .

*Step 1:  $\Psi$  has non-empty values:* indeed, by assumption, there is no tight equilibrium: given  $x \in X$ , it follows that there exists a neighborhood  $V$  of  $x$  (which can be assumed to be compact) and  $(\Phi_i)_{i \in N} \in \prod_{i \in N} W_V(x_{-i})$  such that for every  $z \in V$ , there exists  $i_0 \in N$  such that:

$$\forall (d'_{i_0}, x'_{-i_0}) \in Gr \Phi_{i_0}, u_{i_0}^{\Phi_{i_0}}(d'_{i_0}, x'_{-i_0}) > u_{i_0}(z). \quad (23)$$

For every  $i \in N$ , define  $\alpha_i = \inf_{(d'_i, x'_{-i}) \in Gr \Phi_i} u_i^{\Phi_i}(d'_i, x'_{-i})$ , so that Condition (1) in the definition of  $\Psi(x)$  is satisfied. Furthermore, since the restriction of  $u_i^{\Phi_i}$  to the compact set  $\{(d'_i, x'_{-i}) \in X_i \times V_{-i} : d'_i \in \Phi_i(x'_{-i})\}$  is lower semicontinuous,  $\alpha_i = u_i^{\Phi_i}(d'_i, x'_{-i})$  for some  $(d'_i, x'_{-i}) \in Gr \Phi_i$ . Consequently, for every  $z \in V$ , Inequality 23 implies  $\alpha_{i_0} > u_{i_0}(z)$  for some  $i_0 \in N$ , i.e. Condition (2) is also satisfied.

*Step 2:  $\Psi$  is a  $\vee$ -stable multivalued mapping:* take  $x \in X$ ,  $\alpha$  and  $\alpha'$  in  $\Psi(x)$ . From the definition of  $\Psi(x)$ , there exists  $V \in \mathcal{N}(x)$  (resp.  $V' \in \mathcal{N}(x)$ ), and there exists  $(\Phi_i)_{i \in N} \in \Pi_{i \in N} W_V(x_{-i})$  (resp.  $(\Phi'_i)_{i \in N} \in \Pi_{i \in N} W_{V'}(x_{-i})$ ), both satisfying:

$$\inf_{(d'_i, x'_{-i}) \in Gr \Phi_i} u_i^{\Phi_i}(d'_i, x'_{-i}) \geq \alpha_i \quad (24)$$

$$\forall z \in V, \exists i_0 : \alpha_{i_0} > u_{i_0}(z) \quad (25)$$

$$\inf_{(d'_i, x'_{-i}) \in Gr \Phi'_i} u_i^{\Phi'_i}(d'_i, x'_{-i}) \geq \alpha'_i \quad (26)$$

$$\forall z \in V', \exists i_0 : \alpha'_{i_0} > u_{i_0}(z) \quad (27)$$

For every  $i \in N$ , define  $\Phi''_i \in W_V(x_{-i})$  as follows:  $\Phi''_i(x) = \Phi_i(x)$  if  $\alpha_i \geq \alpha'_i$  and  $\Phi''_i(x) = \Phi'_i(x)$  otherwise. Define  $V'' = V' \cap V$  and  $\alpha'' = \alpha \vee \alpha'$ . To prove that  $\alpha'' \in \Psi(x)$ , prove that  $\Phi''$  and  $V''$  satisfies the two conditions in the definition of  $\alpha'' \in \Psi(x)$ . First, Inequation 25 and Inequation 27 gives: for every  $z \in V''$ , there exists  $i_0$  such that  $\alpha''_{i_0} > u_{i_0}(z)$ , which proves Condition (2). Second, given  $i \in N$ , the case  $\alpha_i \geq \alpha'_i$  implies

$$\inf_{(d'_i, x'_{-i}) \in Gr \Phi''_i} u_i^{\Phi''_i}(d'_i, x'_{-i}) \geq \inf_{(d'_i, x'_{-i}) \in Gr \Phi_i} u_i^{\Phi_i}(d'_i, x'_{-i}) \geq \alpha_i = \alpha''_i,$$

the case  $\alpha_i < \alpha'_i$  being similar. This proves Condition (1). Finally,  $\alpha'' = \alpha \vee \alpha' \in \Psi(x)$ , i.e.  $\Psi$  is a  $\vee$ -stable multivalued mapping.

*Step 3 :  $\Psi$  has open pre-images:* it is immediate from the definition of  $\Psi$ .

From Lemma 20, we get a selection  $\alpha : X \rightarrow \mathbb{R}^N$  of  $\Psi$ , which satisfies the openness condition of Lemma 20. To finish the proof of Theorem 7, we apply a fixed-point theorem à la Kakutani [20] to the following multivalued mapping  $\Psi'$ . Define, for every  $x \in X$ :

$$\Psi'(x) = co\{d \in X : \exists V \in \mathcal{N}(x) \text{ and } (\Phi_i)_{i \in N} \in \Pi_{i \in N} W_V(x_{-i})$$

$$\text{such that for every } i \in N, (d_i)_{i \in N} \in \Pi_{i \in N} \Phi_i(x_{-i}) \text{ and } \inf_{(d'_i, x'_{-i}) \in Gr \Phi_i} u_i^{\Phi_i}(d'_i, x'_{-i}) \geq \sup_{x'' \in V} \alpha_i(x'')\}.$$

First check that for every  $x \in X$ , there exists some local selection of  $\Psi'$  with non-empty, compact, convex values and which has a closed graph. The definition of  $\alpha$  gives  $V \in \mathcal{N}(x)$  and  $\Phi = (\Phi_i)_{i \in N} \in \Pi_{i \in N} W_V(x_{-i})$  such that for every  $i \in N$ , the following inequality is true:  $\inf_{(d'_i, x'_{-i}) \in Gr \Phi_i} u_i^{\Phi_i}(d'_i, x'_{-i}) \geq \alpha_i(x)$ . But  $\alpha$  has been chosen so that the set  $\{x \in X : \inf_{(d'_i, x'_{-i}) \in Gr \Phi_i} u_i^{\Phi_i}(d'_i, x'_{-i}) \geq \alpha_i(x)\}$  is open, consequently  $\Pi_{i \in N} \Phi_i(x_{-i}) \subset \Psi'(x)$  (taking  $V$  smaller if necessary), and  $\Pi_{i \in N} \Phi_i(x_{-i})$  is the local selection of  $\Psi'$  we are looking for. Second,  $\Psi'$  has convex images by definition.

Consequently, we can apply the following generalization of Kakutani's theorem to  $\Psi'$ . A multivalued mapping  $F$  from  $X$  to  $X$  is called *Kakutani* if it has non-empty, compact, convex values and has a closed

graph.

**Theorem 21** *Let  $X$  be a compact subspace of a topological vector space which is locally convex and Hausdorff. Let  $F$  from  $X$  to  $X$ , with convex values, and such that for every  $x \in X$ , there exists a local multivalued selection  $G$  of  $F$  around  $x$ . Then  $F$  admits a fixed point.*

**Proof.** From the compactness of  $X$ , there exists a finite subset  $\{x_1, \dots, x_K\}$  of  $X$ , and for every  $k = 1, \dots, K$ , there exists  $G_k$  a Kakutani multivalued selection of  $F$  from some neighborhood  $V_{x_k}$  of  $x_k$  to  $X$ , where  $V_{x_1}, \dots, V_{x_K}$  is a finite covering of  $X$ . Let  $\beta_1, \dots, \beta_K$  a partition of unit subordinate to the covering  $V_{x_1}, \dots, V_{x_K}$ . Thus, each  $\beta_k$  is a continuous function from  $X$  in  $[0, 1]$ , with support in  $V_{x_k}$ , such that for every  $x \in X$ ,  $\sum_{k=1}^K \beta_k(x) = 1$ . Define  $G(x) = \sum_{k=1}^K \beta_k(x)G_k(x)$ . It is clearly a Kakutani multivalued selection of  $F$  (because  $F$  has convex values). From Kakutani's Theorem, it admits a fixed point, which is a fixed point of  $F$ .

Applying the fixed-point theorem above,  $\Psi'$  admits a fixed point  $\bar{x} \in X$ . This means that there exists  $d(1), \dots, d(K)$  in  $X$  and some non-negative real numbers  $\lambda(1), \dots, \lambda(K)$  with  $\sum_{k=1}^K \lambda(k) = 1$  and  $\bar{x} = \sum_{k=1}^K \lambda(k)d(k)$ , and such that for every  $k = 1, \dots, K$ , there is some  $V \in \mathcal{N}(x)$  and some  $(\Phi_i)_{i \in N} \in \Pi_{i \in N} W_V(x_{-i})$  such that  $u_i(d_i(k), \bar{x}_{-i}) \geq u_i^{\Phi_i}(d_i(k), \bar{x}_{-i}) \geq \alpha_i(\bar{x})$  (the first inequality being a consequence of the definition of  $u_i^{\Phi_i}$ ). Recall that the mapping  $u_i(\cdot, \bar{x}_{-i})$  is quasi concave. Consequently, from the above inequalities for every  $k = 1, \dots, K$ , we obtain  $u_i(\bar{x}) \geq \alpha_i(\bar{x})$  for every  $i \in N$ , which yields a contradiction with Condition (2) in the definition of  $\Psi$ , i.e. the fact that for every  $z$  in some neighborhood  $V'$  of  $\bar{x}$ , there exists  $i_0 \in N$  such that  $\alpha_{i_0}(\bar{x}) > u_{i_0}(z)$ .

## 8.7 Kakutani regularity requirement in Barelli-Soza equilibrium

Observe that  $(x, v) \in \bar{\Gamma}$  is a Barelli-Soza equilibrium if and only if, for every  $i$ :

$$\sup_{V \in \mathcal{V}(x_{-i})} \sup_{\Phi_i \in W_V} \inf_{(d_i, x'_{-i}) \in Gr \Phi_i} u_i(d_i, x'_{-i}) \leq v_i,$$

where  $W_V$  is the set of Kakutani mappings from  $V$  to  $X_i$ . The following lemma prove that a Barelli-Soza equilibrium may not exist if  $W_V$  is replaced by  $\Omega_V$ , the set of multi-valued mapping from  $V$  to  $X_i$ :

**Lemma 22** *In a zero-sum game, there exists  $(x, v) \in \bar{\Gamma}$  such that*

$$\sup_{V \in \mathcal{V}(x_{-i})} \sup_{\Phi_i \in \Omega_V} \inf_{(d_i, x'_{-i}) \in Gr \Phi_i} u_i(d_i, x'_{-i}) \leq v_i \quad (28)$$

*if and only if the game has a value.*

Consequently, since there are quasiconcave games in pure or mixed strategies without a value, a Barelli-Soza equilibrium may not exist without the regularity requirement on  $\Phi_i$ . To prove the lemma, first prove

$$\sup_{V \in \mathcal{V}(x_{-i})} \sup_{\Phi_i \in \Omega_V} \inf_{(d_i, x'_{-i}) \in Gr \Phi_i} u_i(d_i, x'_{-i}) = \sup_{V \in \mathcal{V}(x_{-i})} \inf_{x'_{-i} \in V} \sup_{d_i \in X_i} u_i(d_i, x'_{-i}).$$

Let  $\beta_i = \sup_{\Phi_i \in \Omega_V} \inf_{(d_i, x'_{-i}) \in Gr\Phi_i} u_i(d_i, x'_{-i})$  and  $\alpha_i = \inf_{x'_{-i} \in V} \sup_{d_i \in X_i} u_i(d_i, x'_{-i})$ . For every  $x'_{-i} \in X_{-i}$ , take  $\Phi_i(x'_{-i}) \in \{d_i \in X_i : u_i(d_i, x'_{-i}) \geq \sup_{d_i \in X_i} u_i(d_i, x'_{-i}) - \varepsilon\}$  in the supremum defining  $\beta_i$ : it gives  $\beta_i \geq \alpha_i - \varepsilon$ . The converse inequality  $\beta_i \leq \alpha_i$  is straightforward, and proves the equality above.

Now, let  $S$  (resp.  $T$ ) denote the compact set of strategies of player 1 (resp. 2) and let  $f = u_1 = -u_2$  be a bounded payoff function. Let  $((s, t), (v, -v)) \in \bar{\Gamma}$  satisfy Equation 28, i.e.

$$\sup_{V \in \mathcal{V}(t)} \inf_{t' \in V} \sup_{s \in S} f(s, t') \leq v$$

and

$$\inf_{V \in \mathcal{V}(s)} \sup_{s' \in V} \inf_{t \in T} f(s', t) \geq v.$$

Taking  $V = T$  in the first supremum and  $V = S$  in the second one, we obtain:

$$\inf_{t' \in T} \sup_{s' \in S} f(s', t') \leq v \leq \sup_{s' \in S} \inf_{t' \in T} f(s', t'),$$

that is, the game has a value. The converse is straightforward.

## References

- [1] Aliprantis C.D. and Border K.C. (2007). Infinite Dimensional Analysis: a Hitchhiker's Guide. *Springer*.
- [2] Bagh A. and Jofre A. (2006). Reciprocal Upper Semicontinuity and Better Reply Secure Games: a Comment. *Econometrica*, **74(6)**, 1715-1721.
- [3] Barelli P. and Soza I. (2009). On the Existence of Nash Equilibria in Discontinuous and Qualitative Games. *University of Rochester*.
- [4] Barelli P., Govindan S. and Wilson R. (2013). Competition for a Majority. Preprint.
- [5] Barelli P. and Soza I. (2013). A Note on the Equilibrium Existence Problem in Discontinuous Games. *Econometrica*, **81**, 813-824.
- [6] Baye M., Tian G. and Zhou J. (1993). Characterizations of the Existence of Equilibria in Games with Discontinuous and Non-quasiconcave Payoffs. *Review of Economic studies*, **60(4)**, 935-948.
- [7] Bertrand J. (1883). Théorie mathématique de la richesse sociale. *Journal des savants*, 499-508.
- [8] Bich P. (2010). Existence of Pure Nash Equilibria in Discontinuous and Non Quasiconcave Games. *International Journal of Game Theory*, **38(3)**, 395-410.
- [9] Carmona G. (2009). An Existence Result for Discontinuous Games. *Journal of Economic Theory*, **144(3)**, 1333-1340
- [10] Carmona G. (2011). Understanding some recent Existence Results for Discontinuous Games. *Economic Theory*, **48(1)**, 31-45.

- [11] De Castro L. (2010). Equilibrium Existence and Approximation of Regular Discontinuous Games. *Economic Theory*, **48(1)**, 67-85.
- [12] Dasgupta P. and Maskin E. (1986). The Existence of Equilibrium in Discontinuous Economic Games, I: Theory. *The Review of Economic Studies*, **53(1)**, 1-26.
- [13] Dasgupta P. and Maskin E. (1986). The Existence of Equilibrium in Discontinuous Economic Games, II: Applications. *The Review of Economic Studies*, **53(1)**, 27-41.
- [14] D'Aspremont C., Gabszewicz J.J. and Thisse J.-F. (1979). On Hotelling's 'Stability in Competition'. *Econometrica*, **47(5)**, 1145-1150.
- [15] Fang H. and Morris S. (2006). Multidimensional Private Value Auctions. *Journal of Economic Theory*, **126**, 1-30
- [16] Glicksberg I. (1952). A Further Generalization of the Kakutani Fixed Point Theorem, with Applications to Nash Equilibrium Points. *Proceedings of the American Mathematical Society*, **3**, 170-174.
- [17] Jackson M., Simon L.K., Swinkels J.M. and Zame W.R. (2002). Communication and Equilibrium in Discontinuous Games of Incomplete Information. *Econometrica*, **70(5)**, 1711-1740.
- [18] Jackson M. (2009). Non-existence of Equilibrium in Vickrey, Second-price, and English Auctions. *Rev. Econ. Design*, **13**, 137-145
- [19] Jackson M.O. and Swinkels J.M. (2005). Existence of Equilibrium in Single and Double Private Value Auctions. *Econometrica*, **73**, No., 93-139.
- [20] Kakutani S. (1941). A Generalization of Brouwer's Fixed Point Theorem. *Duke Mathematical Journal*, **8**, 416-427.
- [21] Kim J. and Che Y.-K. (2004). Asymmetric Information about Rivals Types in Standard Auctions. *Games Econ. Behav.*, **46**, 383-397.
- [22] Laraki R., Solan E. and Vieille N. (2005). Continuous-time games of timing. *Journal of Economic Theory*, **120**, 206-238.
- [23] Maskin E. and Riley J. (2000). Equilibrium in Sealed High Bid Auctions. *Rev. Econ. Stud.*, **67**, 439-454.
- [24] McLennan A., Monteiro P.K. and Tourky R. (2011). Games with Discontinuous Payoffs: a Strengthening of Reny's Existence Theorem. *Econometrica*, **79(5)**, 1643-1664.
- [25] Nash J. (1950). Equilibrium points in  $n$ -person games. *Proceedings of the National Academy of Sciences*, **36**, 48-49.
- [26] Nash J. (1951). Non-cooperative Games. *Annals of Mathematics*, **54**, 286-295.
- [27] Prokopovych P. (2011). On Equilibrium Existence in Payoff Secure Games. *Economic Theory*, **48(1)**, 5-16.



- [28] Reny P.J. (1999). On the Existence of Pure and Mixed Strategy Nash Equilibria in Discontinuous Games. *Econometrica*, **67(5)**, 1029-1056.
- [29] Reny P.J. (2009). Further results on the existence of Nash equilibria in discontinuous games. *Mimeo, University of Chicago*.
- [30] Reny P.J. (2011). Strategic Approximations of Discontinuous Games. *Economic Theory*, **48**, 17-29.
- [31] Simon L.K. (1987). Games with Discontinuous Payoffs. *The Review of Economic Studies*, **54(4)**, 569-597.
- [32] Simon L.K. and Zame W.R. (1990). Discontinuous Games and Endogenous Sharing Rules. *Econometrica*, **58**, 861-872.
- [33] Sion M. and Wolfe P. (1957). On a game without a value. In Contributions to the Theory of Games, III, Dresher M., A.W. Tucker and P. Wolfe (eds.). *Annals of Mathematical Studies*, **39**, Princeton University Press, 299-306.
- [34] Vieille N. (2000a). Two-player stochastic games I: a reduction. *Israel Journal of Mathematics*, **119**, 55-91.
- [35] Vieille N. (2000b). Two-player stochastic games II: the case of recursive games. *Israel Journal of Mathematics*, **119**, 93-126.