



HAL
open science

A new model for NGN pervasive eHealth services

Tayeb Lemlouma, Abderrezak Rachedi, Mohamed Aymen Chalouf, Soraya Ait Chellouche

► **To cite this version:**

Tayeb Lemlouma, Abderrezak Rachedi, Mohamed Aymen Chalouf, Soraya Ait Chellouche. A new model for NGN pervasive eHealth services. (Ubi-HealthTech 2013), Jul 2013, Jinhua, China. pp.1 - 5, 10.1109/Ubi-HealthTech.2013.6708061 . hal-00836439

HAL Id: hal-00836439

<https://hal.science/hal-00836439v1>

Submitted on 23 Mar 2014

HAL is a multi-disciplinary open access archive for the deposit and dissemination of scientific research documents, whether they are published or not. The documents may come from teaching and research institutions in France or abroad, or from public or private research centers.

L'archive ouverte pluridisciplinaire **HAL**, est destinée au dépôt et à la diffusion de documents scientifiques de niveau recherche, publiés ou non, émanant des établissements d'enseignement et de recherche français ou étrangers, des laboratoires publics ou privés.

A New Model for NGN Pervasive e-Health Services

Tayeb Lemlouma
IRISA Lab – University of
Rennes 1
Lannion, France
tayeb.lemlouma@irisa.fr

Abderrezak Rachedi
LIGM Lab – University of
Paris-Est MLV
Paris, France
rachedi@univ-mlv.fr

Mohamed Aymen Chalouf
IRISA Lab – University of
Rennes 1
Lannion, France
mohamed-aymen.chalouf@irisa.fr

Soraya Ait Chellouche
IRISA Lab – University of
Rennes 1
Lannion, France
soraya.ait-chellouche@irisa.fr

Abstract—This paper investigates the integration of e-Health in Next Generation Network. It provides a detailed model for an easy integration of e-Health services with the IP Multimedia Subsystem (IMS) with heterogeneous monitoring networks. We show how the functionalities of the IMS can be extended to fully support pervasive and context aware healthcare with third party application services.

Keywords—component; e-Health; Pervasive; NGN; IMS; Context awareness; sensor networks

I. INTRODUCTION

In the core network, the IP Multimedia Subsystem-based Next Generation Network (IMS-NGN) [1] is an appealing environment for providing pervasive applications and services. IMS decouples services from the network by ensuring a separation between data, control and application layers; SIP-based services that can be routed across different autonomous systems and efficient privacy and protection mechanisms for services. These key properties can be used to help the integration of new e-Health solutions and services by Telco operators and hence deliver them to end users in an easy way.

In IMS, services are provided by the mean of an extensible set of Application Servers (AS) that can be useful for the e-Health domain. On the other hand, healthcare places (such as hospitals, clinics or even residential homes) use a wide range of devices with heterogeneous wireless technologies giving the ability to use network services. Healthcare services should be personalized and invoked according to the context of the person (patient, elderly or dependent persons). In the e-Health domain, the context of the person includes key parameters that describe his surrounding environment, his activities of daily living (ADL) and his medical state. Regarding the person's profile, we observe heterogeneous needs of services, assistance and welfare. The other kind of heterogeneity concerns the environment including sensors and actuators with several heterogeneous access technologies.

To date many research works has considered providing context aware e-Health solutions in order to manage both the previous kinds of heterogeneity [2,3,4]. For instance, the work in [4] considers a context aware evaluation of the person's dependency using a new ADL oriented architecture with heterogeneous sensors and different profiles of elderly persons. Regarding the integration of such e-Health solutions in Telco infrastructures, providing e-Health context aware solutions remains an open issue. This is mainly due to the complexity of such infrastructures and the numerous options and capacities that the IMS offers and that still not exploited in e-Health

solutions. In [5], two IMS enabler architectures were proposed: a sensor network architecture using a gateway for solving the heterogeneity and the NEC's Intelligent Context Enabler (ICE) for contextualized sensor data. The work of [6] proposes a new AS with a context awareness server. It focuses on the signaling flow with the SIP protocol in order to implement e-Health services within the IMS.

In this paper we focus on providing healthcare services by considering the chain from the heterogeneous sensor networks (at the patient's level) to Application Servers level passing by the IMS core network. We review the IMS functionalities and identify pertinent changes and extensions in order to trigger context aware pervasive e-Health applications and services. The model that we discuss in this paper is based on existing third-party e-Health services that can be selected and personalized according to the patient's context. For the IMS integration, we focus on providing a road map for a flexible selection and redirection of e-Health AS mainly using the IMS *Initial Filter Criteria* (iFC) [7]. Unlike previous works, such as in [6], we focus on the improvement of the IMS functionalities rather than defining new architectural components. This choice is adopted in order to make the proposal more scalable and facilitate the integration of numerous existing e-Health services in NGN networks.

II. E-HEALTH SERVICES

The provided services in e-Health context are intended to keep patients and elders at their home while allowing them to be as autonomous as possible and provide them with the needed assistance and help in the case of an incident for example. These services include welfare and healthcare services, but they can cover traditional services like multimedia services (IPTV, VoD, VoIP, Video-conference, etc.), safety services (fire detection, intrusion detection, etc.). Among welfare and healthcare services, we can quote:

- Daily drug reminder (very important for the elderly with Alzheimer's disease).
- Detection of impending danger such as the fall and the burn (e.g. alert when a blind person approaches the stairs).
- Detection of incident like fall, heart/epilepsy/schizophrenia attacks, etc.
- Health status telemonitoring such as body temperature, weight, glucose level, pulse, blood pressure, blood oxygen level, etc.
- Remote medical diagnosis.

To provide e-Health services for elders and chronic patients, many projects have proposed some special frameworks. In general, these frameworks are composed of some heterogeneous sensors (medical, environmental, activity, etc.), a local smart node hosting some local services and enabling the communication with the outdoor, and the network which is in charge of the data transport. Moreover, the network can host some key entities (treatment and storage servers) that could be concerned with some e-Health services providing.

III. IMS ARCHITECTURE

In this work we consider the 3GPP *IP Multimedia Subsystem* (IMS) [1] which represents an ideal environment that offers convergent services with the ability to add personalized services based on a set of Application Servers (AS) [1]. Services cover real-time voice and data services and can offer a wide scope of IP-based multimedia services than can contribute to assist patients, elderly and dependent persons.

The IMS Core Network (IM CN) includes three main entities: the *Home Subscriber Server* (HSS), *Call/Session Control Functions* (CSCFs) and the AS (Fig. 1). HSS stores services subscription-related data. CSCFs include: a proxy CSCF (P-CSCF) which is the contact point of an IMS terminal; an interrogating CSCF (I-CSCF) that queries the HSS to find the user location and routes the service requests to the assigned serving CSCF (S-CSCF). S-CSCF contacts the appropriate AS after the evaluation of filter criteria (*iFC: Initial Filter Criteria*) stored on the HSS. The *iFC* [7] is composed of an *application server section* (information about the server to contact) and zero or one instance of a *Trigger Point* section that expresses logical conditions under which an AS is contacted.

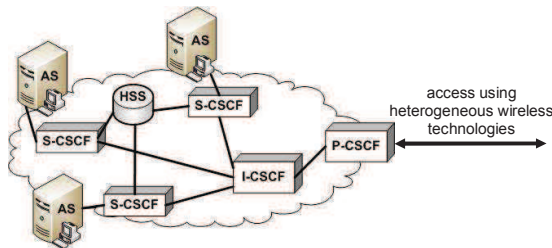

Fig. 1. IMS Global Architecture.

The P-CSCF (Fig. 1) is the first contact point of heterogeneous networks that can be used within the patient's environment to the IM CN. The IP address of P-CSCF is obtained from the IP-Connectivity *Network Bearer Control* point through which the network connectivity is ensured. According to the patient's profile, enabled services accessible within the IM CN could be invoked by sending requests like registration messages to the P-CSCF.

IV. HANDLING THE HETEROGENEOUS ACCESS NETWORKS

In e-Health application, and particularly in « ubiquitous medical care » the patient is equipped with medical devices which form the Body Area Network (BAN) where continuous connectivity between BAN and core network (medical center) must be ensured by an adapted access network technology. For instance, telemonitoring for patients like fall detection service requires a continuous connectivity to notify the medical center

on real time and to trigger other processes. Wireless access networks are the best candidates for this application.

Wireless access networks include wireless local area networks (WLAN), Wireless metropolitan area networks (WMAN), and wireless personal area networks (WPAN), mobile access technologies, such as General Packet Radio Service (GPRS), Wide Code Division Multiple Access (WCDMA), Enhanced Data Rate for Global Evolution (EDGE), 3G/UMTS, and Worldwide Interoperability for Microwave Access (WiMAX) [8, 9, 10]. These technologies have characteristics that perfectly complement each other [8]. Cellular networks, and 3G have significant advantages like wide coverage areas, full mobility, but offer a low bandwidth connectivity. On the other hand WLANs offer high data rate, but with limited coverage areas. WiMAX can provide a mobile broadband for anyone, anywhere, and whatever the technology [10]. That's why it is necessary to introduce heterogeneous access networks. The choice of this technology is significantly influenced by the physical environment (e.g., includes both indoor and outdoor environments) in which the patient is. Therefore, the physical environment in which the medical wireless sensor network is deployed, and the nature of data to be collected (e.g., multimedia, scalar data) must be fully understood. The indoor environment like a home, the building materials, different sources of interferences must be taken into account. WPAN (IEEE 802.15.4) and WLAN (IEEE 802.11) are expected to provide access to IP-based services at high data rates and reduced coverage area can be deployed in indoor environment. However in outdoor context particularly with macro mobility, cellular systems and 3G are best candidates to keep the patient connected to health monitoring system.

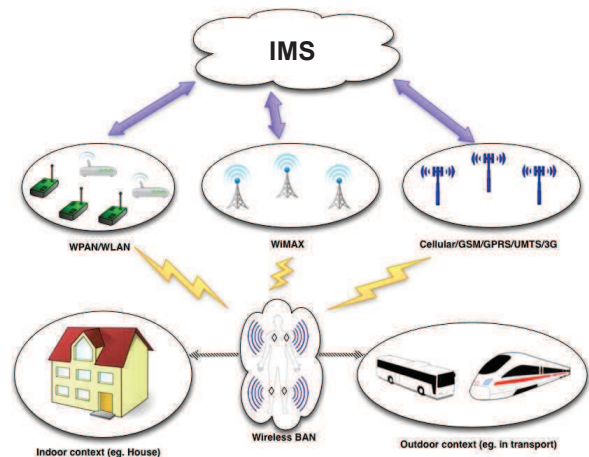

Fig. 2. Heterogeneous Wireless Access Networks in case of e-Health application

Heterogeneous wireless access networks form 4G or next generation of wireless network and this network will support the remote health monitoring of patients anytime and anywhere (as illustrated in Fig. 2).

V. IMS EXTENSION

The objective of our proposal is to facilitate the integration of e-Health services in NGN and make their activation dynamically dependent to the patient's profile. In order to reach this objective, we enrich existing healthcare and monitoring networks by new useful IMS functionalities such as the context-

aware e-Health services invocation, the context updates and person's profiles storing and distribution. These functionalities involve the following IMS components: S-CSCF (iFC), HSS and SLF (Subscription Locator Function).

In order to integrate the managed patients' profiles to the IMS core, we propose the creation of one *IMS subscription* that includes a set of e-Health services. Since an IMS subscription supports natively multiple IMS users, we propose to associate different sets of enabled services within the same subscription by setting up the home network (for instance using the local home box of the home network). Each set of services is identified by a unique identity (the *IMS Private User Identity* [1]) associated to a patient or a monitored person (Fig. 3).

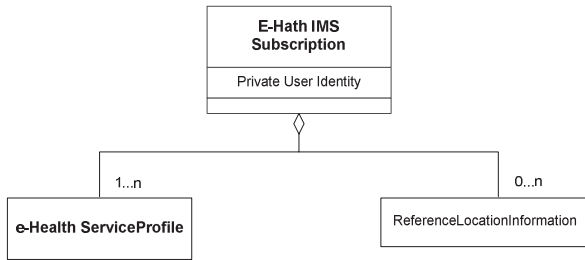

Fig. 3. IMS e-Health Services Integration.

A. e-Health Services Invokation

In the IMS, the service profile is mainly handled by the S-CSCF that evaluates the *IMS Initial Filter Criteria* (Fig. 4) and consequently invoke an application server (AS) or not.

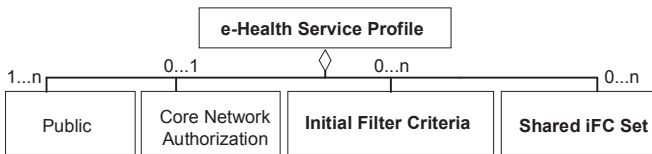

Fig. 4. IMS Initial Filter Criteria.

Each instance of the Initial Filter Criteria class is composed of zero or one instance of a *Trigger Point* class and one instance of an *Application Server* class. Trigger Point class describes the trigger points (SPT) that should be checked in order to find out if the indicated application server should be contacted or not. Each *TriggerPoint* instance represents a boolean expression in Conjunctive or Disjunctive Normal form (CNF/DNF) [7]. Fig. 5, presents an example of the Initial Filter Criteria of a service with a set of SPT and one Application Server.

```

<?xml version="1.0" encoding="UTF-8"?>
<IMSSubscription xmlns:xsi=".."
xsi:noNamespaceSchemaLocation="CxDataType.xsd">
<PrivateID>IMPI1@homedomain.com</PrivateID>
<ServiceProfile>
  <PublicIdentity>
    <BarringIndication>1</BarringIndication>
    <Identity>sip:IMPU1@homedomain.com</Identity>
  </PublicIdentity>
  <PublicIdentity>
    <Identity>sip:IMPU2@homedomain.com</Identity>
  </PublicIdentity>
  <InitialFilterCriteria>
    <Priority>0</Priority>
    <TriggerPoint>
      <ConditionTypeCNF>1</ConditionTypeCNF>
      <SPT>
        <ConditionNegated>0</ConditionNegated>
  
```

```

<Group>0</Group>
<Method>INVITE</Method>
</SPT>
<SPT>
  <ConditionNegated>0</ConditionNegated>
  <Group>0</Group>
  <Method>MESSAGE</Method>
</SPT>
<SPT>
  <ConditionNegated>0</ConditionNegated>
  <Group>0</Group>
  <Method>SUBSCRIBE</Method>
</SPT>
<SPT>
  <ConditionNegated>0</ConditionNegated>
  <Group>1</Group>
  <Method>INVITE</Method>
</SPT>
<SPT>
  <ConditionNegated>0</ConditionNegated>
  <Group>1</Group>
  <Method>MESSAGE</Method>
</SPT>
<SPT>
  <ConditionNegated>1</ConditionNegated>
  <Group>1</Group>
  <SIPHeader>
    <Header>From</Header>
    <Content>"joe"</Content>
  </SIPHeader>
</SPT>
</TriggerPoint>
<ApplicationServer>
  <ServerName>sip:AS1@homedomain.com</ServerName>
  <DefaultHandling>0</DefaultHandling>
</ApplicationServer>
</InitialFilterCriteria>
</ServiceProfile>
</IMSSubscription>
  
```

Fig. 5. An Example of the Initial Filter Criteria.

In the previous example, the condition under which the application server (sip:AS1@homedomain.com) is invoked is the reception -by the S-CSCF- of the following request: SIP Method = "INVITE" OR SIP Method = "MESSAGE" OR (SIP Method="SUBSCRIBE" AND NOT (SIP Header = "from" SIP Content = "joe")).

The *ConditionTypeCNF* attribute defines how the set of SPTs are expressed: either an Ored set of ANDed sets of SPT statements or an ANDed set of Ored sets of statements [7]. Individual SPT statements can also be negated. These combinations are termed, respectively, Disjunctive Normal Form (DNF) and Conjunctive Normal Form (CNF) for the SPT. *ConditionTypeCNF* is a boolean that is *true* when the trigger point associated with the FilterCriteria is a boolean expression in Conjunctive Normal Form (CNF) and *false* if the trigger point is expressed in Disjunctive Normal Form (DNF). Each trigger point is composed by 1 to *n* instances of the class *Service Point Trigger*. Application Server class defines the application server, which is contacted, if the trigger points are met. The *Server Name* is the SIP URL of the application server to contact. The *Default Handling* determines whether the dialog should be released if the Application Server could be reached or not; it is of type enumerated and can take the values: SESSION_CONTINUED or SESSION_TERMINATED [7] (Fig. 5).

We extend the IMS iFC functionalities in order to make them more flexible to integrate e-Health services that are invoked according to the context of the patient or the monitored person. Consequently, conditions to invoke a given e-health service will depend on: the patient's profile, data reported by sensors, e-Health services priorities, user preferences, etc. From a conceptual point of view, the IMS iFC is extended regarding the following IMS iFC classes: *Application Server* (AS) and

Service Point Trigger (SPT) [7]. In addition to the added home network flexibility in invoking services, the *Server Name* (of the AS class) is extended from SIP URL to any URL of an e-Health application server. We generalize the S-CSCF processing to trigger any service (AS or e-Health AS) according to the patient's profile. Finally, the SPT is extended by the expression of logical conditions that become related to any SIP/HTTP/SOAP messages and headers rather than only SIP. In the following, we give two examples of coding these extensions:

- Received methods that can be received by the S-CSCF are extended from SIP methods to the following methods: HTTP GET/POST/PUT/DELETE/PATCH and HTTP-SOAPAction. As explained before, received methods are the basis of the logical conditions (evaluated by the S-CSCF) that invoke the application servers or not. With this extension, iFC conditions related to headers, will consequently include: SIP MESSAGE Body, HTTP body and HTTP-SOAP-ENV_Body. To add more flexibility, sensors and home network can use these methods to report the sensors configuration, sensed data, alarms, user preferences and requests.

```
<SPT>
<!-- an SPT example with a HTTP method -->
<Method>HTTP_PATCH</Method>
</SPT>
<HTTPSOAPHeader>
  <!-- an example with a SOAP header -->
<SOAPAction>SOAP-URI ACTION</SOAPAction>
</HTTPSOAPHeader>
```

- The AS iFC element is extended to included the invocation to any server including servers hosting e-Health services.

```
<ApplicationServer>
<ServerName>
http://192.168.1.9/drugReminderRecorder/record.php
</ServerName>
<DefaultHandling>0</DefaultHandling>
</ApplicationServer>
```

B. e-Health Services Priorities

In our proposal, we maintain the native S-CSCF processing of the iFC *Priority* element (Fig. 5). This means that a Filter Criteria with a higher value of priority value shall be assessed after the Filter Criteria with a smaller priority value have been assessed (the higher the priority value the lower the priority of the Filter Criteria is) [7]. However, we extend the XML semantic of the element to indicate the priority of any e-Health service according to the patient's profile. For example, when a sensor reports an urgent alarm such as the fall or the burn, the alarm handling service become a priority than any other service. We also use the *Priority* element in setting up the initial profile configuration of a given patient or monitored person according to its current needs in terms of e-Health services. For example, if we focus on the dependency of monitored persons [4], the notification of the dependency change allows providing the person with quick assistance related services and consider his needs and allowance by new healthcare services.

C. Updating the Context

Our experience in the e-Health field reported that the needs of a monitored person in terms of e-Health services can be often subject of changes [4]. Consequently, in order to consider these changes in the IMS, stored iFC should be updated according to the patient profile. For example, according to the current person's profile, services priorities could be updated or new

application servers could be added. Since we have extended the support of the SPT methods, as discussed previously, updating the iFC can be easily invoked upon the reception of a given method. In order to integrate this functionality, we use the PATCH method for HTTP [11] to invoke the updates of some parts of the patient's iFC rather than putting a complete replacement of the service profile. The following example shows a simple new iFC that invokes the update of the e-health service profile upon the reception of the PATCH message.

```
<InitialFilterCriteria>
  <Priority>0</Priority>
  <TriggerPoint>
    <SPT>
      <Method>HTTP_PATCH</Method>
    </SPT>
  </TriggerPoint>
  <ApplicationServer>
    <ServerName>
      http://192.168.1.9/updateContext/updt.php
    </ServerName>
    <DefaultHandling>0</DefaultHandling>
  </ApplicationServer>
</InitialFilterCriteria>
```

The following PATCH request shows that the service profile is enriched with a new added service (`./drugReminderRecorder/record.php`) that will be invoked by the S-CSCF upon the reception of the SIP MESSAGE method with certain headers.

```
PATCH /serviceProfil.xml HTTP/1.1
Host: www.myIMSeHealthServices.com
Content-Type: application/xml
If-Match: Public Identity matching
Content-Length: 520
<InitialFilterCriteria>
  <Priority>0</Priority>
  ..
  <SPT>
    ..
    <Method>MESSAGE</Method>
  </SPT>
  <SPT>
    ..
    <SIPHeader>
      <!-- headers and content of the MESSAGE method -->
    </SIPHeader>
  </SPT>
  <ApplicationServer>
    <ServerName>
      http://192.168.1.9/drugReminderRecorder/record.php
    </ServerName>
    <DefaultHandling>0</DefaultHandling>
  </ApplicationServer>
  ..
</InitialFilterCriteria>
```

D. Considering the Electronic Health Record

The Electronic Health Record (EHR) represents a vital component in order to provide e-Health services for a given patient or monitored person. In addition to the private medical history record, used generally in a traditional healthcare system, we use the EHR to save all the e-Health related information that can be useful for a context aware e-Health service. Such information include the needed services and assistance (section II) and their evolution over the time, the current health status of the person such as the dependency degree [4], the setting of the person's sensors and access network (section IV), received data from the monitoring network and emergency contacts and referring doctors and supervisors.

In order to integrate the EHR in the IMS architecture, we identify the IMS HSS as the appropriate place to save the EHR data. This choice is driven by three main reasons. First, the HSS is contacted by the S-CSCF upon the reception of different methods sent by the home network of the monitored person.

Consequently, invoking the e-Health services can be easily dependent to the EHR hence providing context aware and personalized services. The second reason is that the IMS specification defined already an intra-operator interface (the *Sh* interface [1]) that transports *transparent* data i.e. data where the exact representation of the information is not necessarily understood by the HSS or the transport protocol. Finally, since the e-Health services can be used in a pervasive way (section IV) and since the amount of information of EHR can be huge, it is necessary to distribute the EHR across different places in the IMS architecture. Distributing transparent data across different HSS is supported natively in the IMS architecture. The IMS uses the *Subscription Locator Function* (SLF) to identify the address of the HSS that holds the subscriber data for a given user. However, the IMS identification of the HSS is based only on the User Identity. In our approach, we extend this identification to consider the couple: (user identity, e-Health application server identity). In this way, we can distribute different parts of the HER across different HSS. According to e-Health service needed by the monitored person, the appropriate part of the EHR is used when the needed e-Health service is invoked.

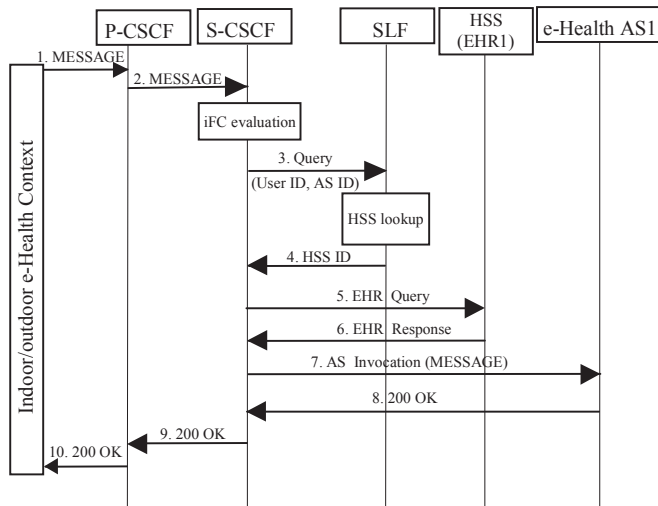

Fig. 6. E-Health Scenario with the Proposed IMS Extensions.

E. Scenario

Fig. 6 shows a general scenario of invoking an e-Health service within the IMS architecture enriched by the previous proposed extensions. Here, the invoked service is presented by the application server *e-Health AS1*. The monitoring network (that can be indoor or outdoor, see section IV) sends a SIP MESSAGE (1) that contains contextual information about the monitored person (health status change, alarm, etc.). The P-CSCF forwards the request to the S-CSCF (2) which knows already the set of iFC related to the person (here we assume that the monitored network was already registered [1] otherwise the iFC should be requested from the HSS). As discussed previously, the S-CSCF evaluates the conditions (according to the received data) and identifies the application server to be

invoked (AS1). The S-CSCF requests the SLF (3) in order to identify the location of the pertinent EHR related to AS1. Once identified (4), the HSS storing the corresponding HER (EHR1) sends the required information in EHR1 (5 and 6). Now, the S-CSCF is able to invoke the e-Health application server AS1 (7) with the context of the monitored person. The person's context is used by third party application servers in order to provide context aware and personalized e-Health services. Note that, in this way, the context includes the contextual information (sent by the monitoring network) and the queried HER.

VI. CONCLUSION AND FUTURE WORK

In this paper we have discussed required extensions, in terms of functionalities, for the integration of e-Health services in NGN. We have shown how to integrate heterogeneous monitoring networks and provide them with third-party application servers in a pervasive and context-aware way.

The following steps of this work will include the improvement of the iFC expressivity regarding the Conjunctive/Disjunctive Normal Form used in the service trigger points (SPT). Also, we will explore the support of the Service Capability Interaction Manager (SCIM): an optional IMS component that manages efficiently the interactions between the AS [1].

REFERENCES

- [1] 3GPP Project; Services and System Aspects, "IP Multimedia Subsystem (IMS); Stage 2 (Release 12)," TS 23.228 V12.0.0, March 2013.
- [2] S. Bhattacharyya, RA. Saravanagru, A. Thangavelu, "Context Aware Healthcare Application", IJCA - International Journal of Computer Applications, Vol. 22, No. 3, 2011.
- [3] M. Domingo, "A Context-Aware Service Architecture for the Integration of Body Sensor Networks and Social Networks through the IP Multimedia Subsystem", IEEE Communications Magazine, Vol. 49, No. 1, pp. 102-108, 2011.
- [4] T. Lemlouma, S. Laborie and P. Roose, "Toward a Context-Aware and Automatic Evaluation of Elderly Dependency in Smart Homes and Cities", WoWMoM/SCUCA, Madrid, Spain, 4-7 June, 2013.
- [5] M. Strohbach, J. Vercher, and M. Bauer, "A Case for IMS, Harvesting the Power of Ubiquitous Sensor Networks", IEEE Vehicular Technology Magazine, Vol. 4, No. 1, 2009.
- [6] A.M., Said and A.W. Ibrahim, "NEW e-Health Signaling Model in the NGN Environment", Healthcom, pp. 391-394, Oct. 2012.
- [7] 3GPP Project; Core Network and Terminals, "IP Multimedia (IM) Subsystem Cx and Dx interfaces; Signaling flows and message contents (Release 11)," TS 29.228 V11.7.0, March 2013.
- [8] A. H. Zahran, B. Liang, and A. Saleh, "Signal Threshold Adaptation for Vertical Hand- off in Heterogeneous Wireless Networks," *Mobile Networks and Applications*, vol. 11, pp. 625-640, 2006.
- [9] A. Hecker, H. Labiod, G. Pujolle, H. Afifi, A. Serhrouchni, and P. Urien, "A New Access Control Solution for a Multi-Provider Wireless Environment," *Telecommunication Systems*, vol.29, no.2, pp. 131-152, 2005.
- [10] F. Xu, L. Zhang, and Z. Zhou, "Interworking of WiMAX and 3GPP Networks Based on IMS," *IEEE Communications Magazine*, vol. 45, pp. 144-150, 2007.
- [11] L. Dusseault, Linden Lab and J. Snell, "PATCH Method for HTTP", RFC 5789, March 2010.