



**HAL**  
open science

# A Hierarchical Model to Estimate Fish Abundance in Alpine Streams by using Removal Sampling Data from Multiple Locations

Christophe Laplanche

► **To cite this version:**

Christophe Laplanche. A Hierarchical Model to Estimate Fish Abundance in Alpine Streams by using Removal Sampling Data from Multiple Locations. *Biometrical Journal*, 2010, vol. 52, pp. 209-221. 10.1002/bimj.200900130 . hal-00831610

**HAL Id: hal-00831610**

**<https://hal.science/hal-00831610>**

Submitted on 7 Jun 2013

**HAL** is a multi-disciplinary open access archive for the deposit and dissemination of scientific research documents, whether they are published or not. The documents may come from teaching and research institutions in France or abroad, or from public or private research centers.

L'archive ouverte pluridisciplinaire **HAL**, est destinée au dépôt et à la diffusion de documents scientifiques de niveau recherche, publiés ou non, émanant des établissements d'enseignement et de recherche français ou étrangers, des laboratoires publics ou privés.



## Open Archive Toulouse Archive Ouverte (OATAO)

OATAO is an open access repository that collects the work of Toulouse researchers and makes it freely available over the web where possible.

This is an author-deposited version published in: <http://oatao.univ-toulouse.fr/>  
Eprints ID: 5609

**To link to this article:** DOI:10.1002/bimj.200900130  
<http://dx.doi.org/10.1002/bimj.200900130>

To cite this version: Laplanche, Christophe *A Hierarchical Model to Estimate Fish Abundance in Alpine Streams by using Removal Sampling Data from Multiple Locations*. (2010) *Biometrical Journal*, vol. 52 (n°2). pp. 209-221. ISSN 0323-3847

Any correspondence concerning this service should be sent to the repository administrator: [staff-oatao@inp-toulouse.fr](mailto:staff-oatao@inp-toulouse.fr)

# A Hierarchical Model to Estimate Fish Abundance in Alpine Streams by using Removal Sampling Data from Multiple Locations

Christophe Laplanche\*

ECOLAB (UMR 5245), Ecole Nationale Supérieure d'Agronomie de Toulouse, 31326  
Castanet-Tolosan, France

The author compares 12 hierarchical models in the aim of estimating the abundance of fish in alpine streams by using removal sampling data collected at multiple locations. The most expanded model accounts for (i) variability of the abundance among locations, (ii) variability of the catchability among locations, and (iii) residual variability of the catchability among fish. Eleven model reductions are considered depending which variability is included in the model. The more restrictive model considers none of the aforementioned variabilities. Computations of the latter model can be achieved by using the algorithm presented by Carle and Strub (*Biometrics* 1978, **34**, 621–630). Maximum a posteriori and interval estimates of the parameters as well as the Akaike and the Bayesian information criterions of model fit are computed by using samples simulated by a Markov chain Monte Carlo method. The models are compared by using a trout (*Salmo trutta fario*) parr (0+) removal sampling data set collected at three locations in the Pyrénées mountain range (Haute-Garonne, France) in July 2006. Results suggest that, in this case study, variability of the catchability is not significant, either among fish or locations. Variability of the abundance among locations is significant. 95% interval estimates of the abundances at the three locations are [0.15, 0.24], [0.26, 0.36], and [0.45, 0.58] parrs per m<sup>2</sup>. Such differences are likely the consequence of habitat variability.

*Key words:* Hierarchical modeling; Model reductions; Removal sampling.

## 1 Introduction

Alpine freshwater systems are subject to anthropogenic disturbances, mainly hydroelectric power plants which alter the particle size distribution of the substrate, the flow rate, and the water temperature (Petts, 1984; The World Commission on Dams, 2000; Petts and Gurnell, 2005). Fish are directly or indirectly subject to the aforementioned disturbances (Magaud *et al.*, 1997; Xenopoulos *et al.*, 2005; Buisson *et al.*, 2008). The monitoring of fish populations can be used to evaluate the ecological health of freshwater systems (Angermeier and Schlosser, 1995; Paller *et al.*, 2000; Oberdorff *et al.*, 2001; Pacheco *et al.*, 2008). Abundance (Hutagalung *et al.*, 1997), biomass (Kraft, 1972; Shirvell, 1979), species assemblage (Matthews, 1998; Paller *et al.*, 2000), genetic alterations, and enzymatic responses (Larno *et al.*, 2001) of fish can be used as indicators of stress at the population level.

---

\* Correspondence author: e-mail: laplanche@gmail.com, Phone: +33-562-193-973, Fax: +33-562-219-901

It is not feasible to remove and count all the fish in a given freshwater stream section to derive an *observed* value of the fish abundance (abundance refers, in the following, to the number of fish per  $\text{m}^2$  of stream). Fish ecologists use various sampling techniques (electrofishing, trapping, and netting), protocols (capture–recapture and removal sampling), probabilistic models, and optimization techniques to derive an *estimate* of the fish abundance by collecting only a fraction of the fish (White *et al.*, 1982; Lobón-Cerviá, 1991; Manly, 1992). Removal sampling by electrofishing is a well-used method to estimate fish abundance in alpine streams: a stream section is closed by nets and fractions of the fish are successively removed by electrofishing. A popular estimate of fish abundance is achieved by using a simple probabilistic model which assumes that the catchability of the fish is constant among fish and across removals (Moran, 1951), and by computing a maximum likelihood estimates of the model parameters (Cowx, 1983; Bedrick, 1994). Carle and Strub (1978) presented an iterative algorithm (CS) to compute such an estimate.

CS leads, however, to biased estimates of fish abundance (Peterson, Thurow, and Guzevich, 2004). Both the bias and the variance of the CS estimator decrease while the population size, the catchability, or the number of removals increase (Mahon, 1980; Hirst, 1994). The bias of the CS estimator increases if the catchability is variable among fish (Mahon, 1980; Mäntyniemi, Romakkaniemi, and Arjas, 2005) or across removals (Schnute, 1983; Riley and Fausch, 1992; Wang and Loneragan, 1996). More accurate estimates of the fish abundance can be achieved by sampling at multiple locations and by using more complex probabilistic models (Heimbuch *et al.*, 1997; Mitro and Zale, 2000; Wyatt, 2002; Royle, 2004). Researchers have created models to estimate fish abundance which take into account random variations of the fish abundance (Wyatt, 2002; Royle, 2004; Dorazio, Jelks, and Jordan, 2005), random variations of the catchability (Wyatt, 2002), variations across removals of the catchability (Otis *et al.*, 1978; Schnute, 1983; Pollock and Otto, 1983; Lee and Chao, 1994; Wang and Loneragan, 1996), and random variations among fish of the catchability (Pollock and Otto, 1983; Lee and Chao, 1994; Dorazio *et al.*, 2005; Mäntyniemi *et al.*, 2005).

Freshwater fish biologists consequently have a large collection of models to estimate fish abundance from removal sampling data. As estimation results are contingent on model choice, it is decisive to choose the most relevant model. The author uses a Bayesian approach to choose the model and estimate the abundance of trout parrs of an alpine stream of the Pyrénées mountain range, France. The author presents first an expanded hierarchical model which takes into account (i) variability of the abundance among locations, (ii) variability of the catchability among locations, and (iii) residual variability of the catchability among fish. The expanded hierarchical model is a compilation of existing models (Halley and Inchausti, 2002; Wyatt, 2002; Royle, 2004; Mäntyniemi *et al.*, 2005) and is therefore briefly presented. Eleven model reductions are considered depending which variability is included in the model. The point and interval estimates of the parameters as well as the goodness-of-fit of the models are then compared in order to highlight the most relevant model. Given that fish abundance and catchability may vary with fish species, fish size, and habitat (Mahon, 1980; Randall, 1990; Bayley and Dowling, 1993; Anderson, 1995; Speas *et al.*, 2004), the author focuses on one freshwater fish species of a given size class living in a similar alpine habitat.

## 2 Models

### 2.1 The expanded hierarchical model

Let  $m$  be the number of locations of similar habitat of an alpine stream inhabited by the fish species of interest. At each location, a stream section is depleted by electrofishing in  $k$  removals. Let  $a_i$  ( $\text{m}^2$ ) be the area of the stream section at the  $i$ -th location and  $c_{ij}$  be the number of fish caught during the  $j$ -th removal at the  $i$ -th location ( $i \in \{1, \dots, m\}, j \in \{1, \dots, k\}$ ). The model parameters are structured in three hierarchical levels as illustrated in Fig. 1 and are described in the following sections.

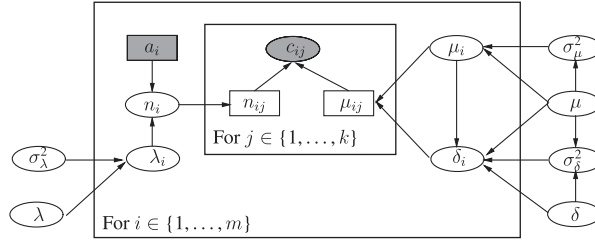

**Figure 1** Directed acyclic graph of the expanded hierarchical model (L). Frames indicate hierarchical levels: removal ( $j \in \{1, \dots, k\}$ ) and location ( $i \in \{1, \dots, m\}$ ). Variables outside frames are variables at the stream hierarchical level. Rectangles: deterministic nodes; ellipses: stochastic nodes; filled nodes: observed variables. Parameters at the removal level are the catchability  $\mu_{ij}$ , the catch  $c_{ij}$ , and the population size  $n_{ij}$ . Parameters at the location level are the area  $a_i$ , the population size  $n_i$ , the abundance  $\lambda_i$  ( $\text{m}^{-2}$ ), the catchability  $\mu_i$ , and the variance  $\delta_i$ . Parameters at the stream level are the abundance  $\lambda$ , the catchability  $\mu$ , and the variances  $\delta$ ,  $\sigma_\lambda^2$ ,  $\sigma_\mu^2$ , and  $\sigma_\delta^2$ .

Parameters at the removal level are the catchabilities  $\mu_{ij}$ , the numbers of caught fish  $c_{ij}$ , and the population sizes  $n_{ij}$ . Parameters at the location level are the areas  $a_i$ , the population sizes  $n_i$ , the abundances  $\lambda_i$  ( $\text{m}^{-2}$ ), the catchabilities  $\mu_i$ , and the variances  $\delta_i$ . Parameters at the stream level are the abundance  $\lambda$ , the catchability  $\mu$ , and the variances  $\delta$ ,  $\sigma_\lambda^2$ ,  $\sigma_\mu^2$ , and  $\sigma_\delta^2$ . Parameters at the removal, location, and stream levels are of dimension  $mk$ ,  $m$ , and 1, respectively.

The expanded hierarchical model accounts for variability among fish of the probability of capture. As shown by Mäntyniemi *et al.* (2005), such a variability leads to a decrease of the catchability across removals. By assuming that the probabilities  $p_{i1f}$  of catching any fish  $f \in \{1, \dots, n_i\}$  during the first removal at the  $i$ -th location are independent and beta distributed ( $p_{i1f} | \alpha_i, \beta_i \sim \text{Beta}(\alpha_i, \beta_i) \forall f$ ) and given that the probability  $p_{ijf}$  of capturing any fish  $f$  during removal  $j \geq 2$  given that the fish have not been captured earlier are equal to  $p_{i1f}$ , Mäntyniemi *et al.* (2005) have shown that the  $p_{ijf}$  are still independent and beta distributed. The expectancy  $\mu_{ij} = E(p_{ijf} | \alpha_i, \beta_i)$  is referred to in the following as the catchability during the  $j$ -th removal at the  $i$ -th location. The expectancy  $\mu_i = \mu_{i1} = \alpha_i / (\alpha_i + \beta_i)$  is referred to as the catchability (during the first removal) at the  $i$ -th location. The variance  $\delta_i = \alpha_i \beta_i / \{(\alpha_i + \beta_i)^2 (\alpha_i + \beta_i + 1)\}$  of  $p_{i1f}$  is bounded by the constraints  $0 < \delta_i < \mu_i(1 - \mu_i)$  (as  $\alpha_i > 0$ ,  $\beta_i > 0$ , and  $0 < \mu_i < 1$ ). Mäntyniemi *et al.* (2005) have shown that  $\mu_{ij} = \mu_i \eta_i / (\eta_i + j - 1)$  with  $\eta_i = \mu_i(1 - \mu_i) / \delta_i - 1$ . Under the hypotheses stated above, the number of fish caught during the  $j$ -th removal at the  $i$ -th location is a binomial

$$c_{ij} | n_{ij}, \mu_{ij} \sim \text{Binomial}(n_{ij}, \mu_{ij}) \quad \forall i, j,$$

where  $n_{ij}$  is the number of fish remaining in the  $i$ -th stream section before the  $j$ -th removal,  $n_{i1} = n_i$  and  $n_{ij} = n_i - \sum_{j'=1}^{j-1} c_{ij'}$  for  $j \in \{2, \dots, k\}$ .

The population sizes  $n_i$  are taken to be independent Poisson random variables of expectancies  $\lambda_i a_i$  (Royle, 2004). The model accounts for spatial, random variations among locations of the parameters  $\lambda_i$ ,  $\mu_i$ , and  $\delta_i$ . The abundances  $\lambda_i$  are assumed independent gamma random variables of expectancy  $\lambda$  and variance  $\sigma_\lambda^2$  (Halley and Inchausti, 2002; Wyatt, 2002). The catchabilities  $\mu_i$  are assumed independent beta random variables of expectancy  $\mu$  and variance  $\sigma_\mu^2$ . Let  $\varepsilon_i = \delta_i / \mu_i(1 - \mu_i)$ ,  $0 < \varepsilon_i < 1$ . The normalized variances  $\varepsilon_i$  are assumed independent beta random variables of expectancy  $\delta / \mu(1 - \mu)$  and variance  $\{\sigma_\delta / \mu(1 - \mu)\}^2$ . The conditional distribution of the parameters at the location level are summarized in Table 1.

The parameters at the stream level are  $\lambda$ ,  $\mu$ ,  $\delta$ ,  $\sigma_\lambda^2$ ,  $\sigma_\mu^2$ , and  $\sigma_\delta^2$ . They are related to the parameters at the location level by the relationships provided in Table 1. They are as a result bound to the following constraints:  $\lambda > 0$ ,  $0 < \mu < 1$ ,  $0 < \delta < \mu(1 - \mu)$  (as  $\delta / \mu(1 - \mu)$  is the expectancy of a beta

**Table 1** Conditional distributions of the parameters at the location level ( $i \in \{1, \dots, m\}$ ).

Variable	Distribution	Expectancy	Variance
$n_i   \lambda_i$	Poisson	$\lambda_i a_i$	$\lambda_i a_i$
$\lambda_i   \lambda, \sigma_\lambda^2$	Gamma	$\lambda$	$\sigma_\lambda^2$
$\mu_i   \mu, \sigma_\mu^2$	Beta	$\mu$	$\sigma_\mu^2$
$\delta_i / \mu_i (1 - \mu_i)   \mu, \delta, \sigma_\delta^2$	Beta	$\delta / \mu (1 - \mu)$	$\{\sigma_\delta / \mu (1 - \mu)\}^2$

distribution),  $\sigma_\lambda^2 > 0$ ,  $0 < \sigma_\mu^2 < \mu(1 - \mu)$  (as  $\sigma_\mu^2$  is the variance of a beta distribution of expectancy  $\mu$ ), and  $0 < \sigma_\delta^2 < \delta\{\mu(1 - \mu) - \delta\}$  (as  $\{\sigma_\delta / \mu(1 - \mu)\}^2$  is the variance of a beta distribution of expectancy  $\delta / \mu(1 - \mu)$ ).

By using Bayes law, the posterior of the parameters is

$$p(\mathbf{n}, \boldsymbol{\lambda}, \boldsymbol{\mu}, \boldsymbol{\delta}, \lambda, \mu, \delta, \sigma_\lambda^2, \sigma_\mu^2, \sigma_\delta^2 | \mathbf{c}) \propto p(\mathbf{c} | \mathbf{n}, \boldsymbol{\mu}, \boldsymbol{\delta}) p(\mathbf{n} | \boldsymbol{\lambda}) \times p(\boldsymbol{\lambda} | \lambda, \sigma_\lambda^2) p(\boldsymbol{\mu} | \mu, \sigma_\mu^2) p(\boldsymbol{\delta} | \delta, \sigma_\delta^2) p(\lambda, \mu, \delta, \sigma_\lambda^2, \sigma_\mu^2, \sigma_\delta^2),$$

where  $\mathbf{n} = (n_i)_{i \in \{1, \dots, m\}}$ ,  $\boldsymbol{\lambda} = (\lambda_i)_{i \in \{1, \dots, m\}}$ ,  $\boldsymbol{\mu} = (\mu_i)_{i \in \{1, \dots, m\}}$ ,  $\boldsymbol{\delta} = (\delta_i)_{i \in \{1, \dots, m\}}$ , and  $\mathbf{c} = (c_{ij})_{i \in \{1, \dots, m\}, j \in \{1, \dots, k\}}$ . The conditional densities of  $\mathbf{n}$ ,  $\boldsymbol{\lambda}$ ,  $\boldsymbol{\mu}$ ,  $\boldsymbol{\delta}$ , and  $\mathbf{c}$  are expressions for standard distributions. The prior  $p(\lambda, \mu, \delta, \sigma_\lambda^2, \sigma_\mu^2, \sigma_\delta^2)$  is defined later. As explained by Spiegelhalter *et al.* (2002), the likelihood of a hierarchical model is not uniquely defined depending on the parameters in focus. The author evaluates in the following relevancy of including the components  $\boldsymbol{\lambda}$ ,  $\boldsymbol{\mu}$ , and  $\boldsymbol{\delta}$  in the model. The author therefore focuses in the following on such parameters, which are parameterized with hyperparameters ( $\lambda$ ,  $\mu$ ,  $\delta$ ,  $\sigma_\lambda^2$ ,  $\sigma_\mu^2$ , and  $\sigma_\delta^2$ ). In that case, the likelihood is  $p(\mathbf{c} | \boldsymbol{\lambda}, \boldsymbol{\mu}, \boldsymbol{\delta}) = p(\mathbf{c} | \mathbf{n}, \boldsymbol{\mu}, \boldsymbol{\delta}) p(\mathbf{n} | \boldsymbol{\lambda})$ .

## 2.2 Model reductions

Eleven model reductions are considered, depending whether the models account for (i) variability among locations of the abundance, (ii) variability among locations of the catchability, and (iii) variability among fish of the catchability. Models which account for such variabilities are abbreviated in the following as models accounting for  $\sigma_\lambda^2$ ,  $\sigma_\mu^2$ , and  $\delta$ , respectively. Among the models, which account for  $\delta$ , some also account for variability among locations of the variability among fish of the catchability. This latter variability is abbreviated as  $\sigma_\delta^2$ . Nesting relationships between the hierarchical models are illustrated in Fig. 2. The more restrictive model is model A and the expanded hierarchical model is model L. Model A assumes that the fish abundance is equal among the  $m$  locations ( $\lambda_i = \lambda \forall i$ ) and that the catchability is the same for all fish, all removals, and all locations [ $p_{ijf} = \mu \forall (i, j, f)$ ]. The assumptions underlying model A are those considered by freshwater fish biologists who estimate fish abundance by summing the removal sampling data across locations before using CS.

## 2.3 Parameter estimates and model comparison

The implementation of models A–L as well as the generation of the Markov chain Monte Carlo (MCMC) samples (Robert and Casella, 2004) are performed with OpenBUGS, an open source version of WinBUGS (Ntzoufras, 2009). The R package BRugs is used to access OpenBUGS functionalities from R. Samples are processed by using R (Crawley, 2007). WinBUGS and R scripts are available on the journal website as Supporting Information. A total of 500 000 samples of the posterior are generated for each model, although fewer iterations provide satisfactory results for some models (*e.g.* 10 000 iterations for models A–D). The burn-in is 1000

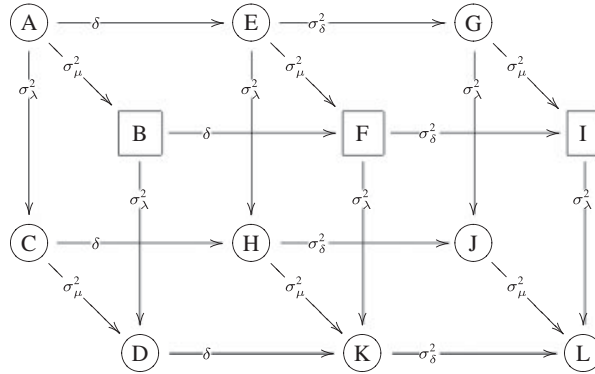

**Figure 2** Three-dimensional commutative diagram illustrating the nesting relationships between the hierarchical models. Only direct nesting relationships are explicitly plotted. Arrows point toward an augmentation of the complexity, arrow labels indicate which component is added to the model:  $\delta$  represents the variability among fish of the catchability (arrows pointing rightward, cube on the left),  $\sigma_\lambda^2$  represents variability among locations of the abundance (arrows pointing downward),  $\sigma_\mu^2$  represents variability among locations of the catchability (arrows pointing toward the reader),  $\sigma_\delta^2$  represents variability among locations of the variability among fish of the catchability (arrows pointing rightward, cube on the right). The complexity of model A is  $2+m$ , complexity increases by 1 by adding the  $\delta$  component and by  $m+1$  by adding either of the  $\sigma_\lambda^2$ ,  $\sigma_\mu^2$ , or  $\sigma_\delta^2$  components. Squared models suggest a low catchability and circled models suggest a high catchability. A backward elimination procedure suggests the reduction  $L \rightarrow J \rightarrow C$ .

iterations. Convergence is assessed by using several chains with different initial values, although no statistical convergence diagnosis has been considered. Several point estimates of the parameters are computed: posterior expectancy, marginal posterior median, marginal posterior mode, joint posterior mode (maximum a posteriori, MAP), and joint likelihood mode (maximum of the likelihood, ML). The interval estimates of the parameters are the 2.5 and 97.5% quantile estimates of their marginal posterior. ML estimates are used to compute estimates of the Akaike information criterion (AIC) and Bayesian information criterion (BIC) (Carlin, Clark, and Gelfand, 2006).

### 3 Data Set and Priors

#### 3.1 Data set

Data have been collected in July 2006 at three locations on the Neste d'Oueil stream (Haute-Garonne, Pyrénées mountain range, France): Saint-Paul (1050 m elevation), Mayrène (1150 m elevation), and Cires (1230 m elevation). The Saint-Paul stream section is 121 m long, 4.7 m wide. The Mayrène section is 2180 m upstream Saint-Paul, 141 m long, 3.8 m wide. The Cires section is 2480 m upstream Mayrène, 171 m long, 2.9 m wide. Streams have been electrofished in two removals. Only brown trout (*Salmo trutta fario*) young-of-the-year parrs (0+) are considered in the following. All trout parrs are less than 75 mm long. The area of the stream sections and the number of parrs caught at each location are provided in Table 2.

**Table 2** Area of the stream sections and number of trout parrs (0+) caught at Cires, Saint-Paul, and Mayrègne in July 2006.

	Cires	Saint-Paul	Mayrègne
$i$	1	2	3
$a_i$ (m <sup>2</sup> )	498	574	541
$c_{i1}$	66	122	187
$c_{i2}$	19	34	63

**Table 3** Priors of the free parameters (stream level).

$\lambda \sim \text{Unif}(0, 100)$
$\mu \sim \text{Unif}(0, 1)$
$\delta \mu \sim \text{Unif}(0, \mu(1 - \mu))$
$\sigma_\lambda^2 \sim \text{Gamma}(1, 1)$
$\sigma_\mu^2 \mu \sim \text{Unif}(0, \mu(1 - \mu))$
$\sigma_\delta^2 \mu, \delta \sim \text{Unif}(0, \delta\{\mu(1 - \mu) - \delta\})$

### 3.2 Priors

The free parameters are assumed to be a priori related solely by the constraints  $\delta < \mu(1 - \mu)$ ,  $\sigma_\mu^2 < \mu(1 - \mu)$ , and  $\sigma_\delta^2 < \delta\{\mu(1 - \mu) - \delta\}$ . In that case, the prior is

$$p(\lambda, \mu, \delta, \sigma_\lambda^2, \sigma_\mu^2, \sigma_\delta^2) = p(\lambda)p(\mu)p(\delta|\mu)p(\sigma_\lambda^2)p(\sigma_\mu^2|\mu)p(\sigma_\delta^2|\mu, \delta).$$

The priors which are assigned to each free parameter are provided in Table 3. The abundance  $\lambda$  is uniformly distributed on  $[0, 100] \text{ m}^{-2}$  by using expert knowledge that parr abundance is less than 100 parrs per m<sup>2</sup> in the Neste d'Oueil. The catchability  $\mu$  and the variances  $\delta$ ,  $\sigma_\mu^2$ , and  $\sigma_\delta^2$  are assigned uniform priors on their definition sets. The variance  $\sigma_\lambda^2$  is gamma distributed,  $\sigma_\lambda^2 \sim \text{Gamma}(1, 1)$ , providing the knowledge that low values of  $\sigma_\lambda^2$  are a priori more likely than higher values. The consequences of the choice of such priors on the results are investigated later.

## 4 Results

MAP and interval estimates of the abundance and the catchability at the stream level are provided in Table 4. Estimates of  $\delta$  (models E–L),  $\sigma_\lambda^2$  (models C, D, H, and J–L),  $\sigma_\mu^2$  (models B, D, F, I, K, and L),  $\sigma_\delta^2$  (models G, I, J, and L) as well as posterior expectancy, marginal posterior median, marginal posterior mode, and ML point estimates were computed, are available as Supporting Information, but are not reported below.

A three-group  $k$ -mean clustering by using the point estimates of the catchabilities (stream level) suggests the classification of the models into: a first group (models F and I) of low catchability ( $\hat{\mu} \in [0.18, 0.23]$ ), model B of intermediate catchability ( $\hat{\mu} = 0.50$ ), and a third group (remaining models) of high catchability ( $\hat{\mu} \in [0.65, 0.72]$ ). Such a classification is highlighted in Fig. 2. Models of the two first groups account for  $\sigma_\mu^2$  without  $\sigma_\lambda^2$ .

BIC estimates of models A–L are provided in Table 4. AIC estimates are similar to BIC estimates and are not reported. Models A, B, E, and G of high BIC are outrightly rejected. Models A, E, and G do not account for either  $\sigma_\lambda^2$  or  $\sigma_\mu^2$ . Model B accounts for  $\sigma_\mu^2$  only. The five models of lowest BIC (models C, D, H, J, and K) account for  $\sigma_\lambda^2$ . Model C leads to the lowest BIC.



Models which account for  $\sigma_\lambda^2$  are models C, D, H, and J–L. Estimates of the parameters at the location level with models C, D, H, and J–L are provided in Table 5. Point estimates of the local abundances are of similar values by using any of these models. Estimate of  $\sigma_\mu^2$  ( $q_{2.5} = 0.0008$ ,

**Table 4** Point and interval estimates of the abundance and the catchability (stream level) and BIC estimates.<sup>a)</sup>

	$\hat{\lambda}$			$\hat{\mu}$			BIC
	$q_{2.5}$	MAP	$q_{97.5}$	$q_{2.5}$	MAP	$q_{97.5}$	
A	0.31	0.33	0.37	0.62	0.71	0.75	129.1
B	0.38	0.42	0.51	0.25	0.50	0.73	102.6
<b>C</b>	<b>0.25</b>	<b>0.66</b>	<b>1.54</b>	<b>0.62</b>	<b>0.71</b>	<b>0.75</b>	<b>61.1</b>
D	0.25	0.78	1.53	0.43	0.70	0.79	67.5
E	0.34	0.33	5.69	0.04	0.69	0.68	131.2
F	0.62	0.97	1.22	0.15	0.23	0.61	72.3
G	0.40	0.35	1.28	0.18	0.65	0.59	119.5
H	0.38	0.61	3.20	0.08	0.71	0.66	63.6
I	0.49	1.24	1.34	0.17	0.18	0.66	75.0
J	0.29	0.44	1.89	0.17	0.67	0.71	70.1
K	0.39	0.90	2.36	0.13	0.72	0.68	70.0
L	0.34	0.52	2.01	0.21	0.69	0.71	77.1

a) Point parameter estimates are joint MAP estimates. Interval parameter estimates are 2.5 and 97.5% marginal posterior quantile estimates.

**Table 5** Point and interval estimates of the parameters in focus (location level) with models C, D, H, and J–L.

	$\hat{\lambda}_1$			$\hat{\lambda}_2$			$\hat{\lambda}_3$		
	$q_{2.5}$	MAP	$q_{97.5}$	$q_{2.5}$	MAP	$q_{97.5}$	$q_{2.5}$	MAP	$q_{97.5}$
<b>C</b>	<b>0.15</b>	<b>0.18</b>	<b>0.24</b>	<b>0.26</b>	<b>0.29</b>	<b>0.36</b>	<b>0.45</b>	<b>0.49</b>	<b>0.58</b>
D	0.15	0.17	0.24	0.25	0.31	0.36	0.45	0.51	0.60
H	0.19	0.18	1.74	0.31	0.30	2.66	0.53	0.49	4.41
J	0.17	0.21	0.77	0.27	0.30	1.22	0.47	0.52	1.99
K	0.20	0.19	1.36	0.32	0.30	1.97	0.56	0.49	2.77
L	0.18	0.19	1.27	0.28	0.31	1.51	0.50	0.51	1.91

	$\hat{\mu}_1$			$\hat{\mu}_2$			$\hat{\mu}_3$		
	$q_{2.5}$	MAP	$q_{97.5}$	$q_{2.5}$	MAP	$q_{97.5}$	$q_{2.5}$	MAP	$q_{97.5}$
D	0.53	0.70	0.81	0.59	0.70	0.80	0.56	0.70	0.74
K	0.10	0.73	0.66	0.11	0.70	0.66	0.12	0.73	0.62
L	0.11	0.69	0.73	0.14	0.68	0.73	0.18	0.69	0.69

	$100\hat{\delta}_1$			$100\hat{\delta}_2$			$100\hat{\delta}_3$		
	$q_{2.5}$	MAP	$q_{97.5}$	$q_{2.5}$	MAP	$q_{97.5}$	$q_{2.5}$	MAP	$q_{97.5}$
J	0.00	0.00	15.07	0.00	0.00	14.67	0.00	0.00	12.77
L	0.15	3.26	15.13	0.12	0.18	14.82	0.03	0.00	12.86

$\hat{\sigma}_\mu^2 = 0.0000$ ,  $q_{97.5} = 0.12$ ) with model L suggests the reduction  $L \rightarrow J$ . Estimates of  $\{\delta_i\}_i$  with model J (Table 5) suggests the reduction  $J \rightarrow C$ , hence the reduction  $L \rightarrow J \rightarrow C$ .

The two-step backward elimination variable selection procedure and the BIC results suggest model C as the most appropriate model. The point estimates of the abundance at Cires, Saint-Paul, and Mayrène are therefore  $\hat{\lambda}_1 = 0.18$ ,  $\hat{\lambda}_2 = 0.29$ , and  $\hat{\lambda}_3 = 0.49 \text{ m}^{-2}$ , respectively. Interval estimates are  $[0.15, 0.24]$ ,  $[0.26, 0.36]$ , and  $[0.45, 0.58] \text{ m}^{-2}$ , respectively.

## 5 Discussion

Depending on which components ( $\delta$ ,  $\sigma_\lambda^2$ ,  $\sigma_\mu^2$ , and  $\sigma_\delta^2$ ) are considered, models provide various results of abundance estimates. The comparison of the models in terms of BIC implies, however, that variability among locations should be included (models C, D, H, and J–L) and that the most reduced model accounting for such a variability (model C) should be preferred. Such a choice is consistent with a backward elimination variable selection procedure suggesting a reduction of model L into model C. Models D, H, and J–L, which include additional variability ( $\delta$ ,  $\sigma_\lambda^2$ , and  $\sigma_\delta^2$ ), provide MAP estimates  $\hat{\lambda}_i$  similar to those with model C with wider confidence intervals. The results suggest, however, that such variabilities do not significantly take place in the study area.

Abundances at Cires, Saint-Paul, and Mayrène are significantly different. Such differences are likely due to habitat variability (Bayley and Dowling, 1993). A new electrofishing campaign together with measurement of habitat quality is to be performed to investigate the relationship between habitat quality and abundance.

The point estimates of some variances, although constrained to be strictly positive, are equal to zero (e.g.  $\hat{\sigma}_\mu^2 = 0$  for model L and  $\hat{\delta}_1 = \hat{\delta}_2 = \hat{\delta}_3 = 0$  for model J). The marginal posteriors of such parameters are exponentially shaped (see Supporting Information), indicating that the joint posterior maximizes if the aforementioned parameters tend toward zero. Null point estimates of the variances therefore do not imply a mistake in simulating or processing MCMC samples. This rather strongly suggests that some reductions should be considered with the above variances forced to be equal to zero, in this case  $L \rightarrow J \rightarrow C$ .

Reported point estimates maximize the joint posterior. The author has chosen to report joint MAP estimates rather than expectancy or median estimates in view of the positive skewness and the bimodality of the marginal posterior of some parameters. MAP estimates have the benefit (or the shortcoming) not to be contingent to the width of the tail of the posterior. For instance, although joint MAP estimates of  $\lambda_1$ ,  $\lambda_2$ ,  $\lambda_3$  with model L are approximately equal to those with model C (Table 5), expectancy estimates would be  $\hat{\lambda}_1 = 0.19$ ,  $\hat{\lambda}_2 = 0.30$ ,  $\hat{\lambda}_3 = 0.51 \text{ m}^{-2}$  with model C and  $\hat{\lambda}_1 = 0.42$ ,  $\hat{\lambda}_2 = 0.57$ ,  $\hat{\lambda}_3 = 0.85 \text{ m}^{-2}$  with model L. Joint MAP estimates are in most cases close to marginal posterior mode estimates. In some cases, however, marginal posterior mode estimates consequentially differ to joint MAP estimates. For instance, the marginal posterior mode estimate of the probability of capture would be  $\hat{\mu} = 0.50$  with model L, whereas the joint MAP estimate is  $\hat{\mu} = 0.69$ . Consequently, to the author's point of view, it is not desirable to use marginal distribution statistics (expectancy, median, and mode), which are routinely provided by WinBUGS to provide abundance estimates. It is preferable to compute joint MAP estimates.

The deviance information criterion (DIC) is a generalization of the AIC by using the posterior distribution of the deviance statistics to compute measures of fit and complexity (Spiegelhalter *et al.*, 2002). DIC relies on the assumption that the posterior expectancy is a good estimate of the model parameters. Consequently, the author has not considered using the DIC as an index of model fit and complexity. AIC and BIC computations rely on a relevant choice of the parameters in focus. In this study, the parameters in focus are  $\lambda$ ,  $\mu$ , and  $\delta$ . The main reason supporting this choice is, as stated earlier, that models A–L are compared in order to evaluate the relevancy of including the  $\lambda$ ,  $\mu$ , and  $\delta$  components into the model. In other words, all models have in common both the components  $\mathbf{c}|\mathbf{n}$ ,  $\mu$ ,  $\delta$ , and  $\mathbf{n}|\lambda$  which are as a consequence included in the likelihood. Another reason in favor of not

focusing on  $\mathbf{n}$  is that the population sizes are highly correlated to the corresponding abundances ( $n_i|\lambda_i \sim \text{Poisson}(\lambda_i a_i)$  is a Poisson regression model) suggesting to consider  $\mathbf{n}$  as a nuisance variable.

Except for  $\sigma_\lambda^2$ , all free parameters are assigned vague priors (Table 3). The prior of  $\lambda$  is uniform on  $[0, 100] \text{ m}^{-2}$ . Such a prior is, however, not non-informative *stricto sensu*. The constraint  $\lambda < 100 \text{ m}^{-2}$  is non-informative (all simulated samples of  $\lambda$  are lower than  $10 \text{ m}^{-2}$ ) but the choice of  $\lambda$  being uniformly distributed on a natural scale is not. Another possibility could be  $\lambda$  uniformly distributed on a log scale. As described by Lambert *et al.* (2005), vague priors are informative and the consequences on estimation results need to be investigated. Informal sensitivity analysis (Gustafson, 1996) is given in the Appendix. Abundance estimates at the stream level are sensitive to the choices of vague priors, whereas abundance estimates at the location level are not. As a result, to the author's point of view, in a case study where few locations are considered, it is more advisable to report abundance estimates at the location level rather than the abundance and variance estimates at the stream level.

The statistical assumptions underlying the expanded hierarchical model are (i) the modeling of the variability among fish of the probability of capture as a beta distribution, (ii) the modeling of the variability of the population sizes as a Poisson distribution, (iii) the assumption that  $\mu_i$  and  $\varepsilon_i$  are beta distributed, and (iv) the assumption that  $\lambda_i$  are gamma distributed ( $i \in \{1, \dots, m\}$ ). Assumptions (i) and (ii) have been discoursed elsewhere (Halley and Inchausti, 2002; Wyatt, 2002; Royle, 2004; Mäntyniemi *et al.*, 2005). Another possibility for assumptions (iii) and (iv) could be to transform the variables and assign normal distributions (*e.g.*  $\text{logit}(\mu_i)|\mu, \sigma_\mu^2 \sim \text{Normal}(\text{logit}(\mu), \sigma_\mu^2)$ ). The distribution choices (iii) and (iv) are not, to the author's point of view, critical, in view of the small number of locations which are considered in the case study and given that  $\mu_i$ ,  $\varepsilon_i$ , and  $\lambda_i$  distributions are parameterized in terms of expectancy and variance. The use of the hierarchical models with a higher number of locations would require, however, a careful choice of the distributions of  $\mu_i$ ,  $\varepsilon_i$ , and  $\lambda_i$  and a sensitivity analysis to evaluate the consequence of such a choice on the estimation results.

The flexibility of the Bayesian framework makes possible future improvements of the expanded hierarchical model. The number of removals is, in this case study, equal for all the locations. The model could nevertheless cope with different number of removals per location. The model could be extended by accounting for a higher hierarchical level (watershed). Several streams would be sampled within a watershed and several locations would be considered per stream. One could use such a model extension to compare abundance of fish populations at the stream level. The expanded hierarchical model does not take into account variability of the catchability across removals, although some experiments suggest it occurs in the field (Otis *et al.*, 1978; Schnute, 1983; Pollock and Otto, 1983; Lee and Chao, 1994; Wang and Loneragan, 1996; Peterson *et al.*, 2004). However, it is not possible to estimate such a variability by using removal sampling data with only two removals. With a higher number of removals, the expanded hierarchical model could be extended and an approach similar to the one presented here could help to decide whether it is appropriate to include variability of the catchability across removals. The model deals so far with removal sampling data of a given fish species, fish size class, and habitat. The model could take into account the effect of fish species (Mahon, 1980), of fish size (Mahon, 1980; Anderson, 1995), and of habitat (Randall, 1990; Bayley and Dowling, 1993; Speas *et al.*, 2004) on the abundance and on the catchability. See for instance the work of Rivot *et al.* (2008) including habitat and time. The author has extended the current model (L) to account for variability of the abundance and the catchability with fish size.

**Acknowledgements** The author is grateful to M. Bonnett for welcoming him in 2007 at the NIWA (New Zealand). The author thanks F. Dauba, G. Durbe, S. Jean, and P. Lim (ECOLAB) for their contribution in collecting the data set, D. Sheeren (DYNAFOR) for the GIS computations, and S. Leguedois (ECOLAB) for her comments on the last version of the article. The author also thanks EDF R&D for financing the electrofishing campaign. The author is very grateful to the reviewers for their help in improving both the clarity and the scientific content of the article.

**Table A1** Point and interval estimates of the abundance and catchability (stream level) and BIC estimates by using the following priors: uniform distribution on the log scale for  $\lambda$  (models A<sub>1</sub> and C<sub>1</sub>), beta distribution for  $\mu$  (models A<sub>2</sub>, A<sub>3</sub>, C<sub>2</sub>, and C<sub>3</sub>), uniform distribution for  $\sqrt{\delta}$  (model E<sub>1</sub>),  $\sigma_\lambda$  (model C<sub>4</sub>),  $\sigma_\mu$  (model B<sub>1</sub>), and  $\sigma_\delta$  (model G<sub>1</sub>).<sup>a)</sup>

		$\hat{\lambda}$			$\hat{\mu}$			BIC
		$q_{2.5}$	MAP	$q_{97.5}$	$q_{2.5}$	MAP	$q_{97.5}$	
A		0.31	0.33	0.37	0.62	0.71	0.75	129.1
A <sub>1</sub>	$\log_{10}(\lambda) \sim \text{Unif}(-2, 2)$	0.31	0.33	0.37	0.62	0.70	0.75	129.1
A <sub>2</sub>	$\mu \sim \text{Beta}(2, 5)$	0.31	0.34	0.38	0.60	0.69	0.74	129.1
A <sub>3</sub>	$\mu \sim \text{Beta}(5, 2)$	0.31	0.33	0.37	0.62	0.71	0.75	129.1
B		0.38	0.42	0.51	0.25	0.50	0.73	102.6
B <sub>1</sub>	$\sigma_\mu   \mu \sim \text{Unif}(0, \sqrt{\mu(1-\mu)})$	0.37	0.42	0.51	0.25	0.48	0.72	102.6
C		0.25	0.66	1.54	0.62	0.71	0.75	61.1
C <sub>1</sub>	$\log_{10}(\lambda) \sim \text{Unif}(-2, 2)$	0.19	0.09	1.27	0.62	0.70	0.75	61.1
C <sub>2</sub>	$\mu \sim \text{Beta}(2, 5)$	0.25	0.44	1.55	0.60	0.69	0.74	61.1
C <sub>3</sub>	$\mu \sim \text{Beta}(5, 2)$	0.25	0.53	1.54	0.62	0.71	0.75	61.1
C <sub>4</sub>	$\sigma_\lambda \sim \text{Unif}(0, 10)$	0.28	0.21	6.62	0.62	0.70	0.75	61.2
E		0.34	0.33	5.69	0.04	0.69	0.68	131.2
E <sub>1</sub>	$\sqrt{\delta}   \mu \sim \text{Unif}(0, \sqrt{\mu(1-\mu)})$	0.33	0.33	4.14	0.06	0.71	0.71	131.0
G		0.40	0.35	1.28	0.18	0.65	0.59	119.5
G <sub>1</sub>	$\sigma_\delta   \mu, \delta \sim \text{Unif}(0, \sqrt{\delta\{\mu(1-\mu) - \delta\}})$	0.40	0.36	2.84	0.08	0.63	0.58	119.4

a) Estimates by using the priors of Table 3 are reproduced (models A–C, E, and G).

**Table A2** Point and interval estimates of the local abundances by using the priors provided in Table A1.

	$\hat{\lambda}_1$			$\hat{\lambda}_2$			$\hat{\lambda}_3$		
	$q_{2.5}$	MAP	$q_{97.5}$	$q_{2.5}$	MAP	$q_{97.5}$	$q_{2.5}$	MAP	$q_{97.5}$
C	0.15	0.18	0.24	0.26	0.29	0.36	0.45	0.49	0.58
C <sub>1</sub>	0.15	0.18	0.24	0.26	0.30	0.36	0.45	0.51	0.58
C <sub>2</sub>	0.15	0.18	0.24	0.26	0.29	0.36	0.45	0.51	0.59
C <sub>3</sub>	0.15	0.18	0.24	0.26	0.30	0.35	0.45	0.50	0.58
C <sub>4</sub>	0.15	0.19	0.24	0.26	0.30	0.35	0.45	0.49	0.58

#### Conflict of Interests Statement

The author has declared no conflict of interest.

## Appendix

Estimates of the abundance and of the catchability at the stream level (Table 5) and estimates of the abundances at the location level (Table 5) by using the priors of Table 3 are compared with

estimates by using the following priors:  $\lambda$  is uniformly distributed on the log scale,  $\mu$  is beta distributed,  $\sqrt{\delta}$ ,  $\sigma_\lambda$ ,  $\sigma_\mu$ , and  $\sigma_\delta$  are uniformly distributed. The consequences of modifying the prior of a free parameter are investigated by using the model of the lowest complexity, which considers such a parameter. Estimates of the abundance and of the catchability (stream level) are provided in Table A1. Given that model C has been selected in this case study as the most appropriate model, the sensitivity of model C regarding the choice of the priors for  $\lambda$  and  $\mu$  is also investigated. Estimates of the local abundances with model C are given in Table A2.

The prior  $\log_{10}(\lambda) \sim \text{Unif}(-2, 2)$  provides the knowledge that low values of  $\lambda$  are more likely than larger values on the natural scale ( $p(\lambda) = 1/\{4\lambda \log(10)\}$ ,  $\lambda \in [10^{-2}, 10^2]$ ). The prior  $\mu \sim \text{Beta}(2, 5)$  provides the knowledge that lower values of the catchability are more likely than higher values (mode 0.2,  $q_{2.5} \simeq 0.04$ ,  $q_{97.5} \simeq 0.64$ ). The prior  $\mu \sim \text{Beta}(5, 2)$  provides the knowledge that higher values are more likely (mode 0.8,  $q_{2.5} \simeq 0.36$ ,  $q_{97.5} \simeq 0.96$ ). Uniform priors for standard deviations provide the knowledge that lower values of the variances are more likely than higher values (e.g.  $p(\sigma_\mu^2|\mu) = 1/\{2\sqrt{\mu(1-\mu)}\sigma_\mu\}$ ). The use of a bounded flat prior  $\sigma_\lambda \sim \text{Unif}(0, \sigma_{\lambda,\max})$  simulates the use of an improper flat prior  $\sigma_\lambda \propto 1$ . Simulated samples of  $\sigma_\lambda^2$  saturate at the upper boundary  $\sigma_{\lambda,\max}^2$  no matter how large the value of  $\sigma_{\lambda,\max}$ . The use of a uniform prior for  $\sigma_\lambda^2$  (see Supporting Information) leads to similar results.

## References

- Anderson, C. (1995). Measuring and correcting for size selection in electrofishing mark-recapture experiments. *Transactions of the American Fisheries Society* **124**, 663–676.
- Angermeier, P. and Schlosser, I. (1995). Conserving aquatic biodiversity: beyond species and populations. *American Fisheries Society Symposium* **17**, 402–414.
- Bayley, P. and Dowling, D. (1993). The effects of habitat in biasing fish abundance and species richness estimates when using various sampling method in streams. *Polskie Archiwum Hydrobiologii* **40**, 5–14.
- Bedrick, E. (1994). Maximum-likelihood estimation for the removal method. *The Canadian Journal of Statistics* **22**, 285–293.
- Buisson, L., Thuiller, W., Lek, S., Lim, P. and Grenouillet, G. (2008). Climate change hastens the turnover of stream fish assemblages. *Global Change Biology* **14**, 2232–2248.
- Carle, F. and Strub, M. (1978). A new method for estimating population size from removal data. *Biometrics* **34**, 621–630.
- Carlin, B., Clark, J. and Gelfand, A. (2006). Elements of hierarchical Bayesian inference. In: Clark, J., Gelfand, A. (Eds.), *Hierarchical Modelling for the Environmental Sciences*. Oxford University Press, Oxford, pp. 3–24.
- Cowx, I. (1983). Review of the methods for estimating fish population size from survey removal data. *Fisheries Management* **14**, 67–82.
- Crawley, M. (2007). *The R Book*. Wiley, UK.
- Dorazio, R., Jelks, H. and Jordan, F. (2005). Improving removal-based estimates of abundance by sampling a population of spatially distinct subpopulations. *Biometrics* **61**, 1093–1101.
- Gustafson, P. (1996). Robustness considerations in Bayesian analysis. *Statistical Methods in Medical Research* **5**, 357–373.
- Halley, J. and Inchausti, P. (2002). Lognormality of ecological time series. *Oikos* **99**, 518–530.
- Heimbuch, D., Wilson, H., Weisberg, S., Vølstad, J. and Kazyak, P. (1997). Estimating fish abundance by stream surveys by using double-pass removal sampling. *Transactions of the American Fisheries Society* **126**, 795–803.
- Hirst, D. (1994). An improved removal method for estimating animal abundance. *Biometrics* **50**, 501–505.
- Hutagalung, R., Lim, P., Belaud, A. and Lagarrigue, T. (1997). Influence of anthropogenic disturbance on freshwater fish communities: case of the Garonne River in Toulouse (France). *International Journal of Limnology* **33**, 263–279.
- Kraft, M. E. (1972). Effects of controlled flow reduction on a trout stream. *Journal of the Fisheries Research Board of Canada* **29**, 1405–1411.

- Lambert, P., Sutton, A., Burton, P., Abrams, K. and Jones, D. (2005). How vague is vague? A simulation study of the impact of the use of vague prior distributions in MCMC using WinBUGS. *Statistics in Medicine* **24**, 2401–2428.
- Larno, V., Laroche, J., Launey, S., Flammarion, P. and Devaux, A. (2001). Responses of chub (*Leuciscus cephalus*) populations to chemical stress, assessed by genetic markers, DNA damage and cytochrome P4501A induction. *Ecotoxicology* **10**, 145–158.
- Lee, S. and Chao, A. (1994). Estimating population size via sample coverage for closed capture–recapture models. *Biometrics* **50**, 88–97.
- Lobón-Cerviá, J. (1991). *Dinámica de Poblaciones de Peces en Ríos: Pesca Eléctrica y Métodos de Capturas Sucesivas en la Estima de Abundancias*. Monografías del Museo Nacional de Ciencias Naturales, Madrid.
- Magaud, H., Migeon, B., Morfin, P., Garric, J. and Vindimian, E. (1997). Modelling fish mortality due to urban storm run-off: interacting effects of hypoxia and un-ionized ammonia. *Water Research* **31**, 211–218.
- Mahon, R. (1980). Accuracy of catch-effort methods for estimating fish density and biomass in streams. *Environmental Biology of Fishes* **5**, 343–363.
- Manly, B. (1992). *The Design and Analysis of Research Studies*. Cambridge University Press, Cambridge.
- Mäntyniemi, S., Romakkaniemi, A. and Arjas, E. (2005). Bayesian removal estimation of a population size under unequal catchability. *Canadian Journal of Fisheries and Aquatic Sciences* **62**, 291–300.
- Matthews, W. (1998). *Patterns in Freshwater Fish Ecology*. Chapman and Hall, London.
- Mitro, M. and Zale, A. (2000). Predicting fish abundance using single-pass removal sampling. *Canadian Journal of Fisheries and Aquatic Sciences* **57**, 951–961.
- Moran, P. (1951). A mathematical theory of animal trapping. *Biometrika* **38**, 307–311.
- Ntzoufras, I. (2009). *Bayesian Modeling Using WinBUGS*. Wiley, Hoboken, New Jersey.
- Oberdorff, T., Pont, D., Hugué, B. and Chessel, D. (2001). A probabilistic model characterizing fish assemblages of French rivers: a framework for environmental assessment. *Freshwater Biology* **46**, 399–415.
- Otis, D., Burnham, K., White, G. and Anderson, D. (1978). Statistical inference from capture data on closed animal populations. *Wildlife Monographs* **62**, 1–135.
- Pacheco, A., Albrecht, M. and Caramaschi, E. (2008). Ecology of two species of *Pachyurus* (Perciformes, Sciaenidae) from the Tocantins River, in the region impounded by the Serra da Mesa hydroelectric dam, Goias. *Iheringia Serie Zoologia* **98**, 270–277.
- Paller, M., Reichert, M., Dean, J. and Seigle, J. (2000). Use of fish community data to evaluate restoration success of a riparian stream. *Ecological Engineering* **15**, 171–187.
- Peterson, J., Thurow, R. and Guzevich, J. (2004). An evaluation of multipass electrofishing for estimating the abundance of stream-dwelling salmonids. *Transactions of the American Fisheries Society* **133**, 462–475.
- Petts, G. (1984). *Impounded Rivers. Perspectives for Ecological Management*. John Wiley & Sons, Chichester.
- Petts, G. and Gurnell, A. (2005). Dams and geomorphology: research progress and future directions. *Geomorphology* **71**, 27–47.
- Pollock, K. and Otto, M. (1983). Robust estimation of population size in closed animal populations from capture–recapture experiments. *Biometrics* **39**, 1035–1049.
- Randall, R. (1990). Effect of water temperature, depth, conductivity and survey area on the catchability of juvenile Atlantic salmon by electric fishing in New Brunswick streams. In: Cowx, I. (Ed.), *Developments in Electric Fishing*. Fishing News Books, Oxford, pp. 79–90.
- Riley, S. and Fausch, K. (1992). Underestimation of trout population size by maximum likelihood removal estimates in small streams. *North American Journal of Fisheries Management* **12**, 768–776.
- Rivot, E., Prevost, E., Cuzol, A., Baglinière, J.-L. and Parent, E. (2008). Hierarchical Bayesian modelling with habitat and time covariates for estimating riverine fish population size by successive removal method. *Canadian Journal of Fisheries and Aquatic Sciences* **65**, 117–133.
- Robert, C. and Casella, G. (2004). *Monte Carlo Statistical Methods*. Springer-Verlag, New York.
- Royle, J. (2004). *N*-mixture models for estimating population size from spatially replicated counts. *Biometrics* **60**, 108–115.
- Schnute, J. (1983). A new approach to estimating populations by the removal method. *Canadian Journal of Fisheries and Aquatic Sciences* **40**, 2153–2169.
- Shirvell, C. (1979). *The Effects of Water Abstraction on a Trout Stream*. PhD thesis, University of Otago, Dunedin.

- Speas, D., Walters, C., Ward, D. and Rogers, R. (2004). Effects of intraspecific density and environmental variables on electrofishing catchability of brown and rainbow trout in the Colorado River. *North American Journal of Fisheries Management* **24**, 586–596.
- Spiegelhalter, D., Best, N., Carlin, B. and van der Linde, A. (2002). Bayesian measures of model complexity and fit. *Journal of the Royal Statistical Society Series B* **64**, 583–639.
- The World Commission on Dams (2000). *Dams and Development. A New Framework for Decision Making*. Earthscan Publications Ltd, London and Sterling, VA.
- Wang, Y. and Loneragan, N. (1996). An extravariation model for improving confidence intervals of population size estimates from removal data. *Canadian Journal of Fisheries and Aquatic Sciences* **53**, 2533–2539.
- White, G., Anderson, D., Burnham, K. and Otis, D. (1982). Capture–recapture and Removal Methods for Sampling Closed Populations. Los Alamos National Laboratory. LA-8787-NERP.
- Wyatt, R. (2002). Estimating riverine fish population size from single- and multiple-pass removal sampling using a hierarchical model. *Canadian Journal of Fisheries and Aquatic Sciences* **59**, 695–706.
- Xenopoulos, M., Lodge, D., Alcamo, J., Märker, M., Schulze, K. and van Vuuren, D. (2005). Scenarios of freshwater fish extinctions from climate change and water withdrawal. *Global Change Biology* **11**, 1–8.