



**HAL**  
open science

## Architecture and Protocols of EPC-LTE with relay

Yangyang Chen, Xavier Lagrange

► **To cite this version:**

Yangyang Chen, Xavier Lagrange. Architecture and Protocols of EPC-LTE with relay. 2013, pp.25.  
hal-00830621

**HAL Id: hal-00830621**

**<https://hal.science/hal-00830621v1>**

Submitted on 5 Jun 2013

**HAL** is a multi-disciplinary open access archive for the deposit and dissemination of scientific research documents, whether they are published or not. The documents may come from teaching and research institutions in France or abroad, or from public or private research centers.

L'archive ouverte pluridisciplinaire **HAL**, est destinée au dépôt et à la diffusion de documents scientifiques de niveau recherche, publiés ou non, émanant des établissements d'enseignement et de recherche français ou étrangers, des laboratoires publics ou privés.

Collection des rapports de recherche de Telecom Bretagne

RR-2013-02-RSM



# Architecture and Protocols of EPC-LTE with relay

Yangyang Chen (Telecom Bretagne)

Xavier Lagrange (Telecom Bretagne)



## Abstract

This document is about relay's architecture and protocol. It first introduces the overall EPS network architecture and functions, including both the core network and the access network. The structure of LTE transmissions and the protocol architecture for the user plane as well as the control planes are discussed. Then the document gives a general overview of relays. Generally, relays can be classified into 2 types, type-1 relay and type-2 relay. And depending on the spectrum used for the access link and backhaul link, type-1 relay can be further distinguished into inband relay and outband relay. This document focuses on the inband relays that have been standardized, including subframe enhancements, the user plane protocol architecture and the control plane protocol architecture for relay. Lastly, some procedures related to relay, such as relay startup procedure, embedded UE attach procedure and handover procedure, are addressed.

# 1 EPS Architecture Overview

The Long Term Evolution (LTE) was initiated in 2004 with the objective of providing a new radio access technology focusing on packet-switched data. In parallel to the development of LTE, the overall 3GPP network architecture has been also undergoing an evolution, termed System Architecture Overview (SAE), including both the radio access network LTE and the Evolved Packet Core (EPC) network. The LTE and the EPC together are called the Evolved Packet System (EPS), where both the core network and the radio access are fully packet-switched. The overall network architecture is shown in Figure 1.

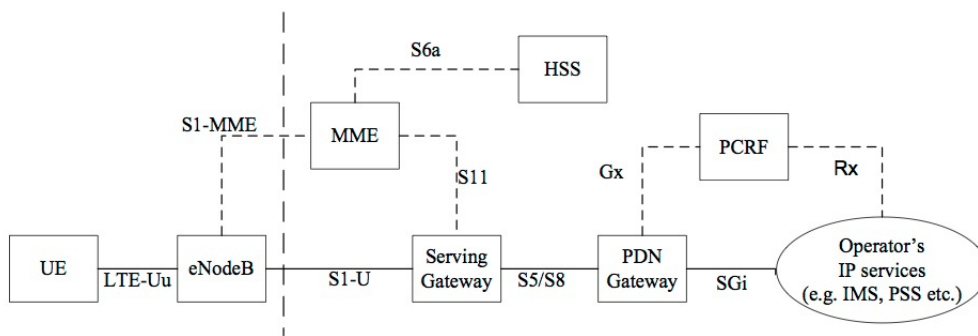

Figure 1: The EPS network architecture, source [1]

In the EPC network many network elements exist, but there is only one element in the radio access network, which is the evolved NodeB (eNodeB). Each element is connected through interfaces that are standardized. The EPC and LTE network are described in more details below.

## 1.1 The Core Network

The EPC is very different from the GSM/GPRS core network used for GSM and WCDMA/HSPA. It only supports the packet-switched domain without the support of the circuit-switched domain. The EPC is mainly responsible for the control of the UE and the establishment of bearers. In EPS *bearers* are used to route IP traffic from a gateway in the PDN to the UE. A bearer can be seen as an IP packet flow with a defined Quality of Service (QoS) between the gateway and the UE.

The *Mobility Management Entity* is the control-plane node of the EPC. It's responsible for bearer management, connection management, and it deals with security keys. In a word, MME processes the signaling between the UE and the

EPC. The protocols running between the UE and the CN are referred as the *Non-Access Stratum* (NAS) protocols.

The *Serving Gateway* (S-GW) is the user-plane node connecting the EPC to the LTE RAN. All user IP packets are forwarded through the S-GW, it serves as a mobility anchor when UEs move between eNodeBs. It also has the information about the bearers when the UE is in idle state and temporarily buffers downlink data while the MME is paging the UE to re-establish the bearers. Besides, it also performs some administrative functions like collecting information for charging (e.g. the volume of data sent to or received from the user) [2].

The *Packet Data Network Gateway* (PDN-GW) connects the EPC to the internet. It's responsible for IP address allocation for the UE and QoS enhancement according to the rules from the PCRF (see below). This is performed based on Traffic Flow Templates (TFTs). In addition, it's the mobility anchor for non-3GPP technologies, such as CDMA2000.

The *Policy Control and Charging Rules Function* (PCRF) is responsible for policy control, QoS handling and controlling the charging functionalities in the Policy Control Enforcement Function, which resides in the P-GW. It decides how a certain data flow will be treated.

The *Home Subscriber Service* (HSS) is a database containing subscriber information. It's also in charge of generating security information and performing the authentication of the user.

## 1.2 The Access Network

### 1.2.1 Interfaces and Functions

The LTE radio access network uses a flat architecture and consists of a network of eNodeBs. There is no controller in LTE, which is a big difference compared with the previous radio access network. LTE integrates the radio control function into the eNodeB, which allows tight interaction between the different protocol layers. Normally the eNodeBs are connected to each other through the *X2* interface, and to the EPC through the *S1* interface, more specifically, to the MME through the *S1-MME* interface and to the S-GW through the *S1-U* interface. The protocols that run between the eNodeBs and the UE are known as the *Access Stratum* (AS) protocols. The interfaces of LTE radio access network are shown in Figure 2.

The eNodeBs are responsible for all radio related functions, which can be summarized as follows:

1. **Radio Resource Management.** It includes radio bearer control, radio admission control, radio mobility control, scheduling and resource allocation in uplink and downlink.

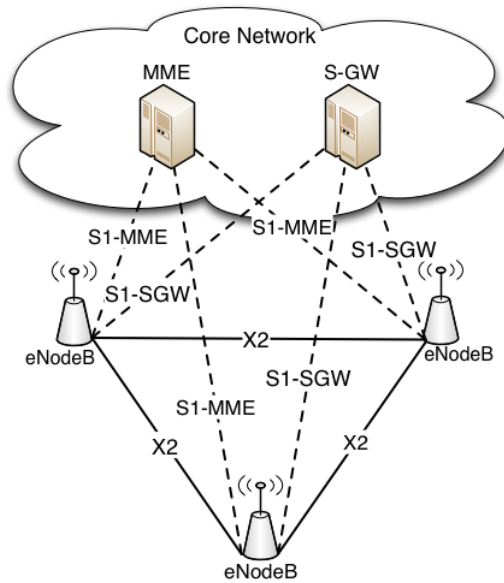

Figure 2: The EPC network architecture

2. **Header Compression.** It is done in *Packet Data Convergence Protocol* (PDCP) to compress IP packet header, which helps to efficiently utilize radio resource, especially for small packets like VoIP.
3. **Security.** Encrypt the data sent over the radio interface.
4. **Connectivity to the EPC.** This consists of the signaling towards the MME and the bearer path towards the S-GW.

### 1.2.2 Packet Access on LTE

In the above sections, the overall LTE architecture and functions were discussed, now we will discuss the structure of LTE transmissions.

As we know, OFDM (Orthogonal Frequency-Division Multiplexing) is used in LTE as the basic physical layer transmission scheme for both downlink and uplink. The OFDM subcarrier spacing equals 15 kHz. In the time domain, LTE transmissions are organized into radio frames with a length of 10 ms, each radio frame is divided into ten equal 1 ms subframes. Each subframe contains two time slots with a length of 0.5 ms, each slot contains certain number of OFDM symbols and cyclic prefix, the frame structure is shown in Figure 3.

As it is illustrated in Figure 3, LTE defines two cyclic prefix length, the normal cyclic prefix and the extended cyclic prefix, corresponding to seven and six

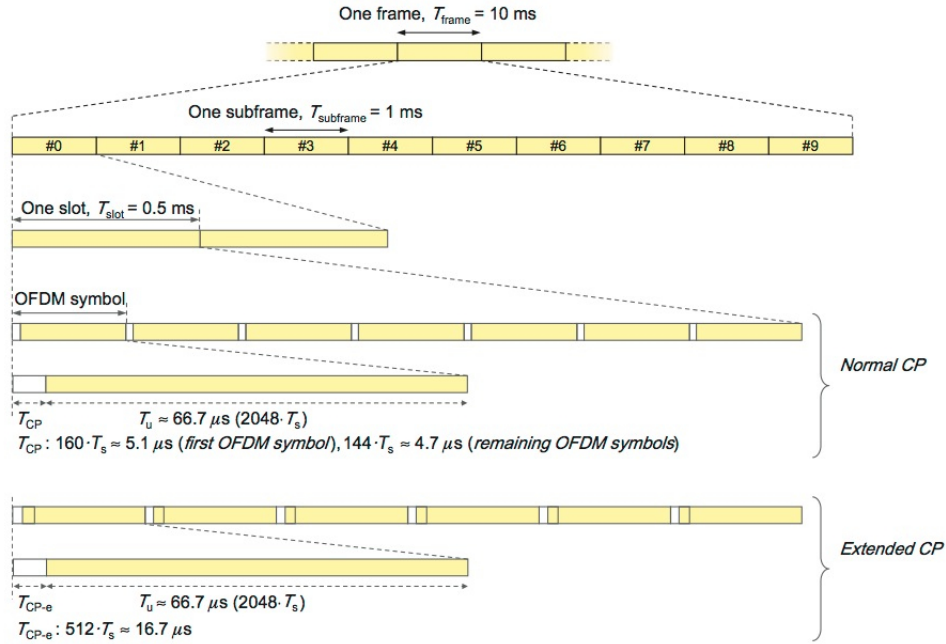

Figure 3: The LTE frame structure, source [2]

OFDM symbols per slot respectively. The reason for doing this is because the extended cyclic prefix is useful in specific environments with extensive delay spread, for example in very large radius cells.

In LTE the smallest physical resource is a *resource element*, which contains one frequency symbol (on one subcarrier in the frequency domain and one OFDM symbol in the time domain). Multiple resource elements are grouped into *resource blocks* (RB). Each resource block contains 12 consecutive subcarriers in the frequency domain and one slot in the time domain. Thus there are  $7 \times 12 = 84$  resource elements in one resource block if normal cyclic prefix is configured,  $6 \times 12 = 72$  resource elements in one resource block in the case of extended cyclic prefix. The minimum scheduling unit can be defined as a resource-block pair which consists of two time-consecutive resource blocks within one subframe.

It's important to note that in LTE, each downlink subframe is divided into a control region and a data region, some resource elements are reserved for control data. The control region carries L1/L2 signaling to control uplink and downlink data transmissions. Normally L1/L2 control signaling contains downlink scheduling assignments, uplink scheduling grants and hybrid-ARQ acknowledgements. These control signalings are transmitted within the first part of each subframe. They allow terminals to decode downlink scheduling assignments as early as pos-

sible, which leads to a more efficient process. Basically the control region occupies one, two, or three OFDM symbols. which is shown in Figure 4.

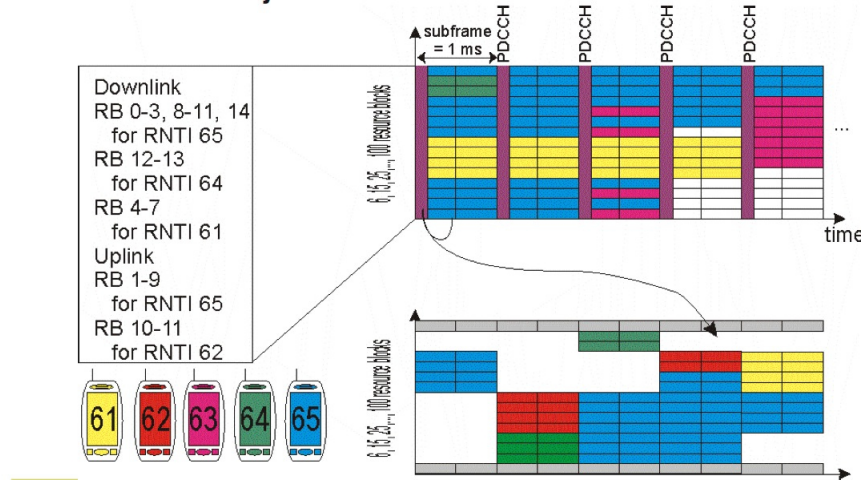

Figure 4: LTE control and data region, source [3]

As can be seen in Figure 4, the allocated RBs and the associated RNTIs are given in the first 1-3 symbols. RNTI is Radio Network Temporary Identifier, each terminal is identified by a RNTI. Normally the control region contains four different physical channel types.

1. The *Physical Control Format Indicator Channel* (PCFICH), notifies the terminal about the size of the control region in terms of the number of OFDM symbols, one, two or three OFDM symbols. The PCFICH contains two bits of information and is coded into a 32-bit codeword. The codeword is mapped to 16 resource elements.
2. The *Physical Downlink Control Channel* (PDCCH) is used to carry downlink control information like downlink scheduling assignments and uplink scheduling grants. Downlink scheduling assignments include information that UE needs to properly receive, demodulate and decode the DLSCH. Uplink scheduling grants notify the UE about the resources and transport format used for uplink (ULSCH) transmissions. Hybrid-ARQ acknowledgements are response to ULSCH transmissions. These information should be transmitted in every subframe. The terminal decodes them and knows whether there are some resource blocks for itself.
3. The *Physical Hybrid-ARQ Indicator Channel* (PHICH) is used to transmit hybrid-ARQ acknowledgements for uplink PUSCH transmissions.



4. The *Relay Physical Downlink Control Channel* (R-PDCCH) is a new control channel used to transmit control information for relay nodes. It's not transmitted in the common control region. We'll discuss R-PDCCH in the relay section.

## 1.3 Protocol Architecture

The radio protocol architecture for LTE can be separated into control plane architecture and user plane architecture. The LTE protocol stack is shown in Figure 5.

### 1.3.1 Protocol Layers

The protocol stack consists of the following sublayers: PHY (Physical), MAC (Medium Access Control), RLC (Radio Link Control) and PDCP (Packet Data Convergence Protocol). As seen in the figure, they are common to the user and control planes. The different protocol layers are summarized below: **PHY** layer is responsible for coding/decoding, modulation/demodulation, multi-antenna processing, and mapping of the signal to the appropriate physical time-frequency resources. It also handles mapping of transport channels to physical channels.

**MAC** layer is responsible for multiplexing data from different radio bearers, hybrid-ARQ retransmission and scheduling for uplink and downlink. There is only one MAC entity per UE.

**RLC** layer is in charge of segmentation, concatenation, retransmission and in-sequence delivery to higher layers. The RLC reorders the RLC PDUs if they are received out of sequence due to the HARQ operation performed in the MAC layer. There is one RLC entity per radio bearer configured for a terminal. Note that the functions of the RLC layer are performed by RLC entities. RLC entities have three transmission modes: Transparent Mode (TM), Unacknowledged Mode (UM), and Acknowledged Mode (AM). The use of TM RLC is very limited. Only RRC messages which do not need RLC configuration can use the TM RLC, such as broadcast system information. UM RLC is mainly utilized by delay-sensitive data, such as VoIP. AM RLC is mainly utilized by error-sensitive application, such as web browsing, the most important feature of AM RLC is 'retransmission'. UM and AM modes are chosen by eNodeB during the RRC radio bearer setup procedure based on the QoS requirements of the EPS bearer.

**PDCP** layer compresses the IP header of user packets in order to reduce the number of bits that transmitting over the radio interface. Another main function of PDCP is ciphering. There is one PDCP entity per radio bearer configured for a terminal.

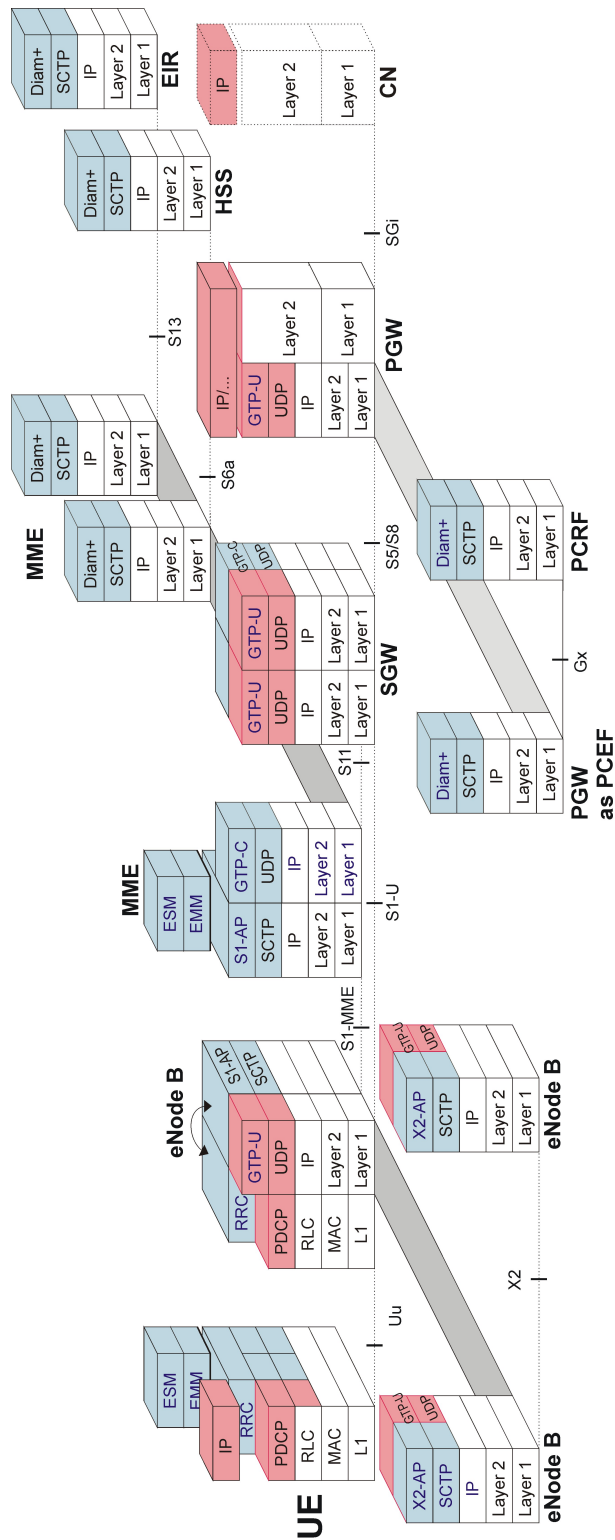

Figure 5: Global view of the LTE-EPC protocol stack

### 1.3.2 User Plane

On the user plane, packets in the core network are encapsulated in a specific EPC protocol and tunneled between the P-GW and eNodeB. Different tunneling protocols are used on different interfaces. The GPRS Tunnelling Protocol (GTP-U) is used over the core network interfaces. This protocol tunnels user data between eNodeB and S-GW as well as between S-GW and P-GW. The GTP-U encapsulates all user IP packets. The difference between the control plane and the user plane is mainly at the RLC (Radio Link Control) layer, they can be distinguished by different RLC entities.

### 1.3.3 Control Plane

The control plane protocols are responsible for connection and bearer setup, mobility and security. The control plane of the access stratum handles radio-specific functionality. The control plane of the non-access stratum is handled by the MME, includes EPS bearer management, authentication, security, and idle-mode procedures like paging.

The **RRC** protocol is a layer-3 access stratum protocol located in the eNodeB. It is the main controlling function in the access stratum, it's responsible for establishing the radio bearers, broadcasting system information, transmitting paging message from the MME, and configuring all the lower layers using RRC signaling between the eNodeB and the UE.

The **S1-AP** (S1 Application Protocol) protocol is used on the control plane between the eNB and the core network, the MME. It provides signalling service like the S1 bearer set-up and paging initiation.

The **GTP-C** (GPRS Tunnelling Protocol Control Plane) protocol is the control part of GTP. It is used on the control plane between the LTE core nodes, MME, S-GW, PDN-GW for specific signalling about the EPS bearer set-up and forwarding of UE context during MME change.

The **Diameter** protocol is the next generation Authentication, Authorization, and Accounting (AAA) protocol, which is widely used in the IMS architecture for IMS entities to exchange AAA-related information. The basic concept behind DIAMETER is to provide a base protocol that can be extended in order to provide AAA services to new access technologies.

## 2 General Overview of Relay

For efficient heterogeneous network planning, 3GPP LTE-Advanced has introduced the concept of Relay. The Relay Nodes are low power eNodeBs that provide

enhanced coverage and capacity at cell edges. One of the main benefits of relay is to provide extended LTE coverage in target areas at low cost.

## 2.1 Types of Relay

A basic requirement of deploying relay is that the relay should be transparent to the terminal. From the perspective of the terminal, it should not be aware of whether it's connected to a relay node or to a regular eNodeB. The point is to make sure release 8/9 terminals can also be served by relays, despite the fact that relays are introduced in release 10. Generally, relays can be classified into 2 types, type-1 relay and type-2 relay.

1. **Type-1 relay:** from the view of the UE, type-1 relay looks like a regular eNodeB, it has its own cell ID, synchronization, broadcast, and control channels. 3GPP has standardized specifications for type-1 relay in release 10.
2. **Type-2 relay:** type-2 relay can transmit data on PDSCH, but it does not have a separate physical cell ID. Terminals served by type-2 relay get control signaling of PDCCH from the eNodeB.

Regarding to relay, the term *backhaul link* refers to the eNodeB-relay connection, the term *access link* refers to the relay-terminal connection. This is illustrated in Figure 6.

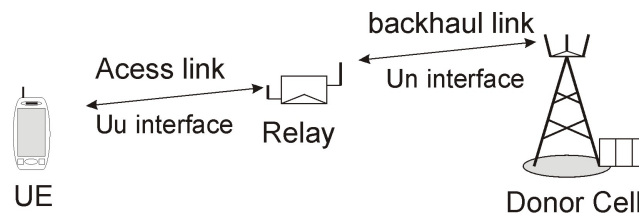

Figure 6: Access and backhaul links, source [4]

In 3GPP, it has been agreed to standardize specifications for type-1 relay technology since release 10, so we focus on type-1 relay in the following.

## 2.2 Type-1 Relay

Type-1 Relay is a layer-3 node which has been standardized in September 2010. In this section, we summarize its system architecture, protocols, signaling procedures.

Since the relay communicates with both eNodeB and terminals, interference

between the access link and backhaul link must be avoided. Isolation between the access link and backhaul link can be achieved within time, frequency and spatial domains. Depending on the spectrum used for the access link and backhaul link, type-1 relay can be further distinguished into inband relay and outband relay.

Inband relay means that the backhaul link and the access link operate in the same spectrum. Isolation is done in the time domain, some additional mechanisms are required to avoid interference between the access link and the backhaul link. This is shown in Figure 7.

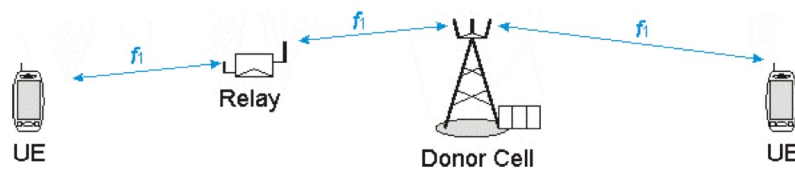

Figure 7: Inband Relay, source [4]

Outband relay means that the backhaul link and the access link use different frequencies. Isolation between the backhaul link and the access link is obtained in the frequency domain. Relay can operate with full duplex in this case. Outband relay is shown in Figure 8.

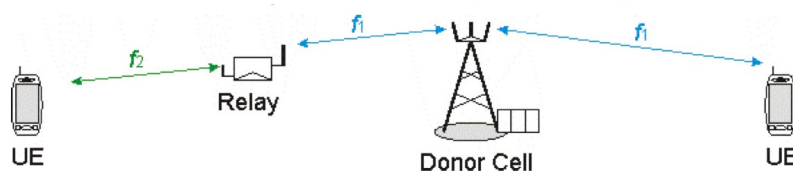

Figure 8: Outband Relay, source [4]

Outband relays provide more capacity, because the access link can use the spectrum all by itself. But from Figure 7 and Figure 8 we can see, inband relays are more efficient from the spectrum usage point of view, because both access link and backhaul link share the same spectrum. In-band operation is more complex, isolation in the time domain needs sophisticated configuration of the Un interface. So we will focus on inband relays in the following.

## 2.3 Type-2 Relay

As discussed above, type-2 relay nodes are transparent, they do not have separate physical cell ID, so they do not create any new cells and transmit cell-specific reference signals and PDCCH. In this case, type-2 relays are mainly used to enhance capacity instead of coverage extension.

# 3 Inband Relay

## 3.1 Subframe enhancements

To ensure the relay is not transmitting on the access link while it is receiving on the backhaul link, some subframe should be reserved for the backhaul link. For the uplink transmission, the scheduler in the relay can block UE uplink transmission through the uplink grant scheduling. But for the downlink transmission, the embedded UEs are always expecting the control data on PDCCH in every subframe.

To reserve blank subframe for the backhaul link, a specific frame, which was originally defined for MBSFN (Multicast Broadcast Single Frequency Network), is used. MBSFN subframe includes control data while most of the frames are targeted for multicast transmission. In a MBSFN subframe, UEs expect cell-specific reference signals and control signaling to be transmitted only in the first or two OFDM symbols, which means that the remain part of the subframe can be empty. By configuring some subframes as MBSFN subframes, the relay can stop transmitting on the data region of these subframes and receive from the donor eNodeB on the backhaul link. The number of MBSFN subframes in each radio frame depends on the current load on the backhaul link, which is configured either via RRC signaling from the donor eNodeB to the relay or via OAM.

It's important to note that since a relay needs to transmit some control information in the first two symbols of the MBSFN subframe, it can not listen the control part of the subframe sent from the donor eNodeB on the backhaul link. So control signaling for relay node can not be transmitted using the regular PDCCH. As a result, a new control channel called Relay PDCCH (R-PDCCH) is introduced. R-PDCCH should start late enough so that the relay could finish transmitting its own control region and switch from transmit mode to receive mode. R-PDCCH is mainly used to dynamically assign resources to different relays and uplink grant scheduling. The mechanism of how relay works is illustrated in Figure 9 and Figure 10. The two figures have different options on whether the donor eNB transmits when relay is transmitting on the access link. If the donor eNB transmits to other direct UEs when relay is transmitting on the access link, there will be interference to embedded UEs.

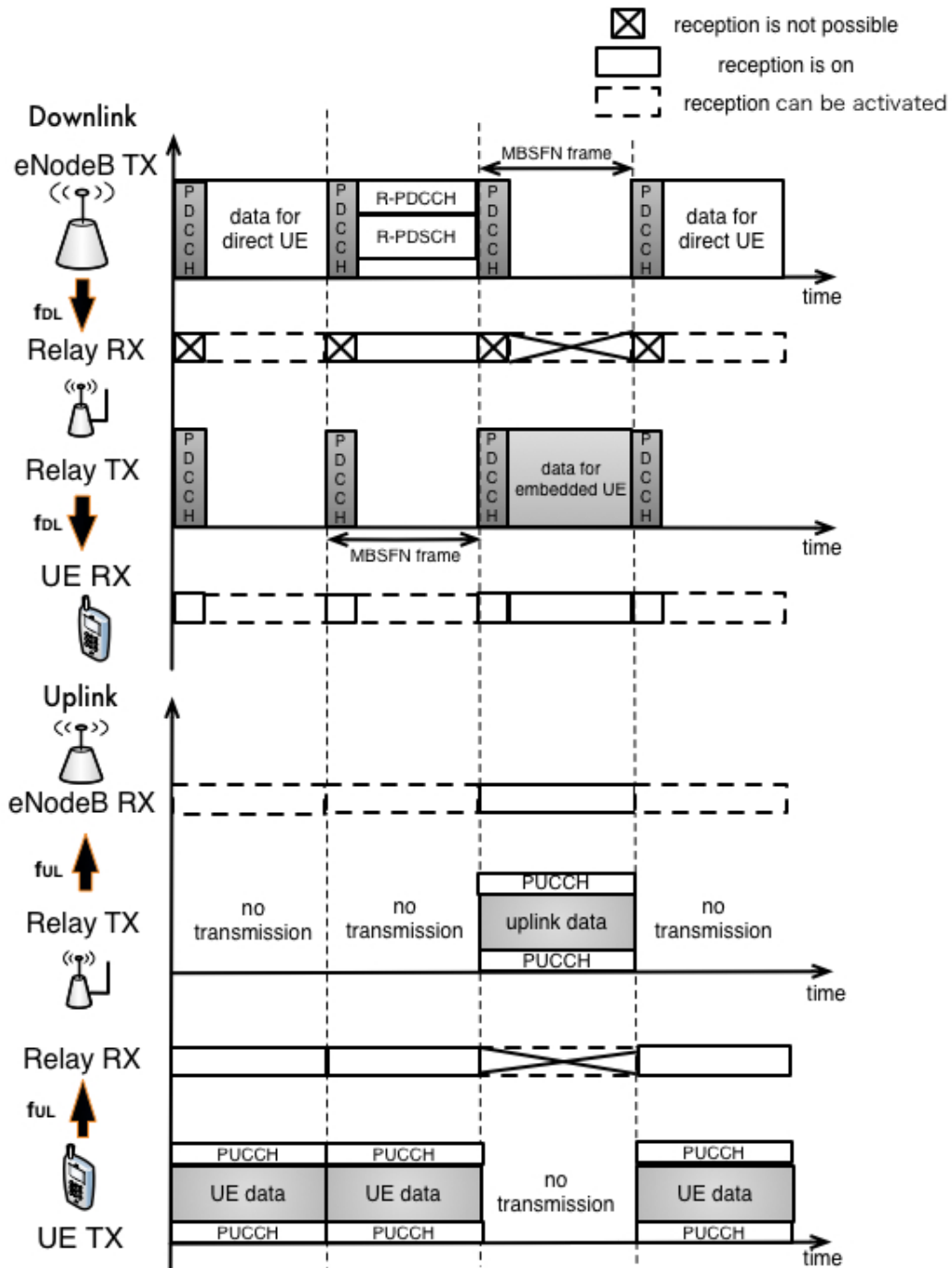

Figure 9: The mechanism of relay without donor eNodeB transmission

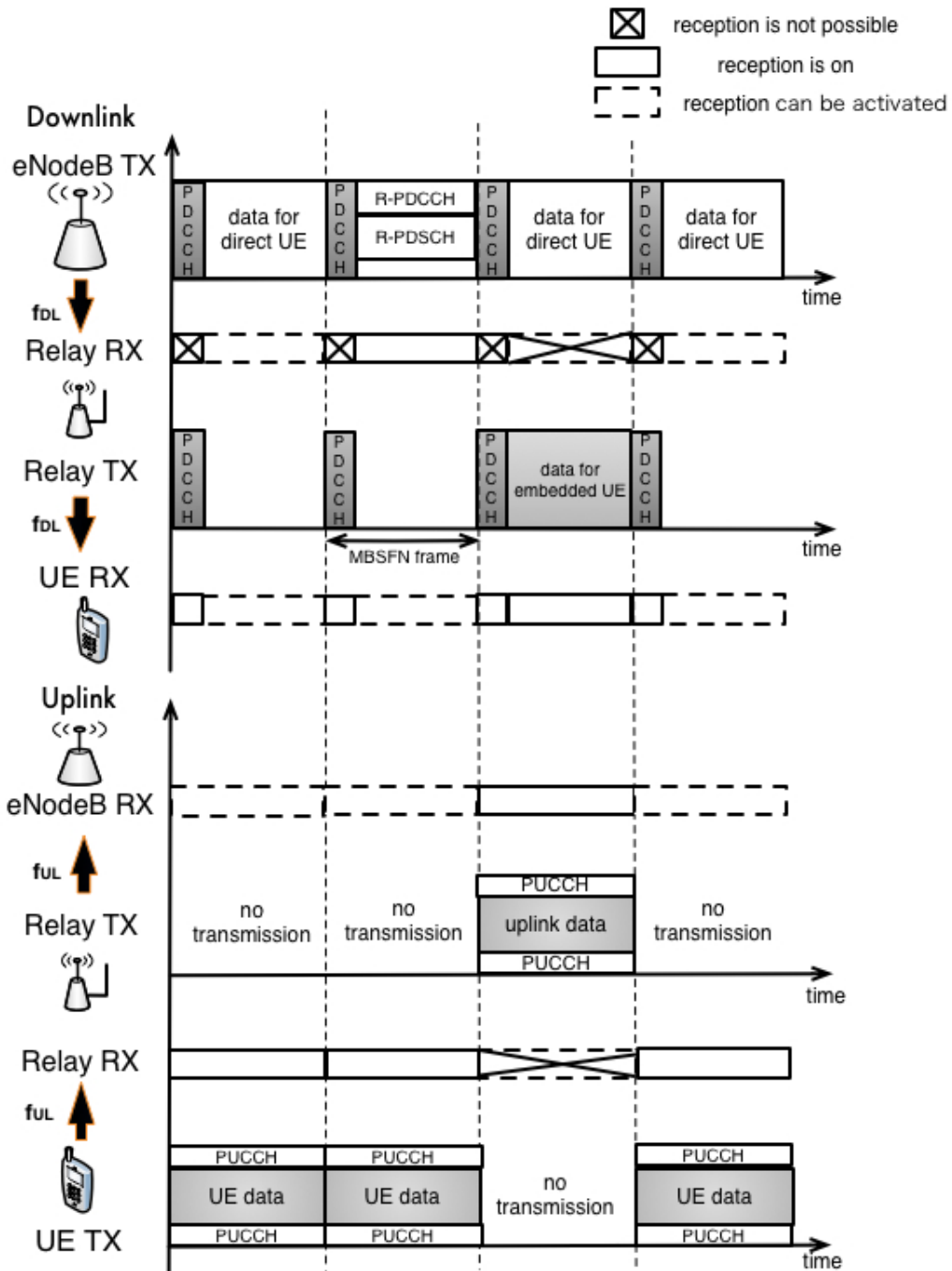

Figure 10: The mechanism of relay with donor eNodeB transmission



### 3.2 User plane aspects

The user plane protocol architecture for relay is shown in Figure 11. In relay case "home eNodeB GW" function is added into the donor eNodeB. The GTP protocol is used to transfer user data from the donor eNodeB to relay station. There is a GTP tunnel per UE bearer spanning from the S-GW/P-GW of the UE to the donor eNodeB, then this GTP tunnel switches to another GTP tunnel at the donor eNB through one-to-one mapping and transfers user data from the donor eNB to the relay station. The donor eNB classifies the incoming packets into RN radio bearers based on the QCI of the UE bearer.

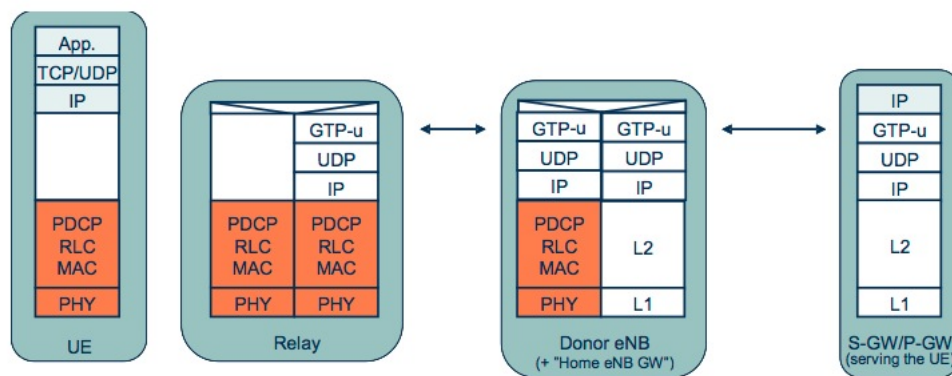

Figure 11: The user plane protocol architecture for relay, source[7]

### 3.3 Control plane aspects

The control plane protocol architecture for relay is shown in Figure 12. The S1-AP messages are sent between the MME and the donor eNB, and between the donor eNB and the relay. Each S1-AP message contains two information elements: eNB UE S1AP ID and MME UE S1AP ID [5]. There is a S1-AP proxy mechanism at the donor eNB which is similar to the home eNB GW function. S1 signaling connections are processed by the donor eNB. For all UE-dedicated procedures the donor eNB processes and forwards all S1 messages between the relay node and the MMEs. When donor eNB receives the S1-AP messages, it modifies S1-AP UE IDs, transport layer address and GTP TEIDs but leaves other parts of the message unchanged. In this case, there is mapping about S1-AP UE IDs at the donor eNB. For non-UE-dedicated S1-AP procedures, they are terminated at the donor eNB and handled locally between the relay and the donor eNB, between the donor eNB and the MME(s). This operation is transparent for the MME and the

relay. From the view of the relay, it looks like it connects to the MME directly. The S1-AP messages are encapsulated by SCTP/IP. In this case, no new functionality is required in the S1-AP (and X2-AP) protocols [6].

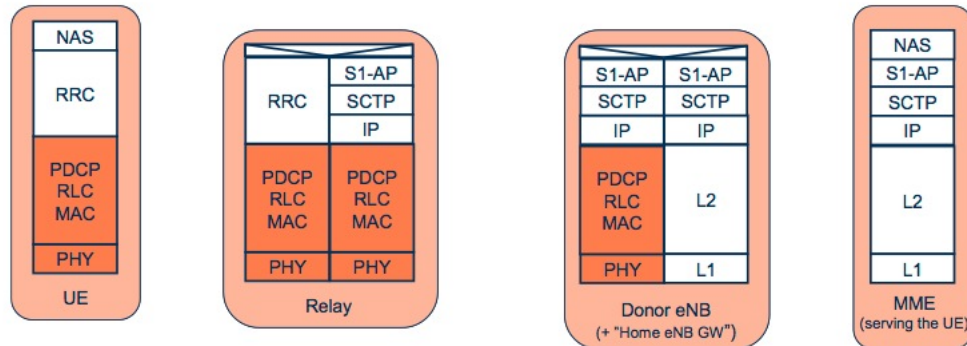

Figure 12: The control plane protocol architecture for relay, source[7]

### 3.4 Relay Startup Procedure

When a new relay is installed in the network, it will attach itself to the network automatically. The procedure is based on the normal UE attach procedure. There are two phases during the relay startup procedure. The RN startup procedure is illustrated in Figure 13. Regarding to the details of the setup procedures of S1 interface and X2 interface, please refer to appendix.

In the first phase, the relay node creates RRC connection to the eNodeB and attaches itself as a regular UE for initial configuration. The MME creates a "UE" context which holds relay subscription information downloaded from the HSS. During this phase the relay node obtains the list of all possible donor eNodeBs which it can connect to from Operation Administration Maintenance (OAM), then the relay node detaches from the network as a UE and triggers the second phase. The MME performs the S-GW and P-GW selection for the RN as a normal UE. Note that the eNodeB that relay connects to retrieves initial configuration in the first phase may not be the donor eNodeB of the relay. The details of RN attach as a regular UE are shown in Figure 14.

In the second phase, the relay node connects to the donor eNodeB selected from the list obtained in the first phase. The relay node sends a RN indication to the donor eNodeB during RRC connection establishment. After knowing this, the donor node can select a MME which is supporting RN functionality. The DeNB sends the RN indicator and the IP address of the S-GW/P-GW function embedded

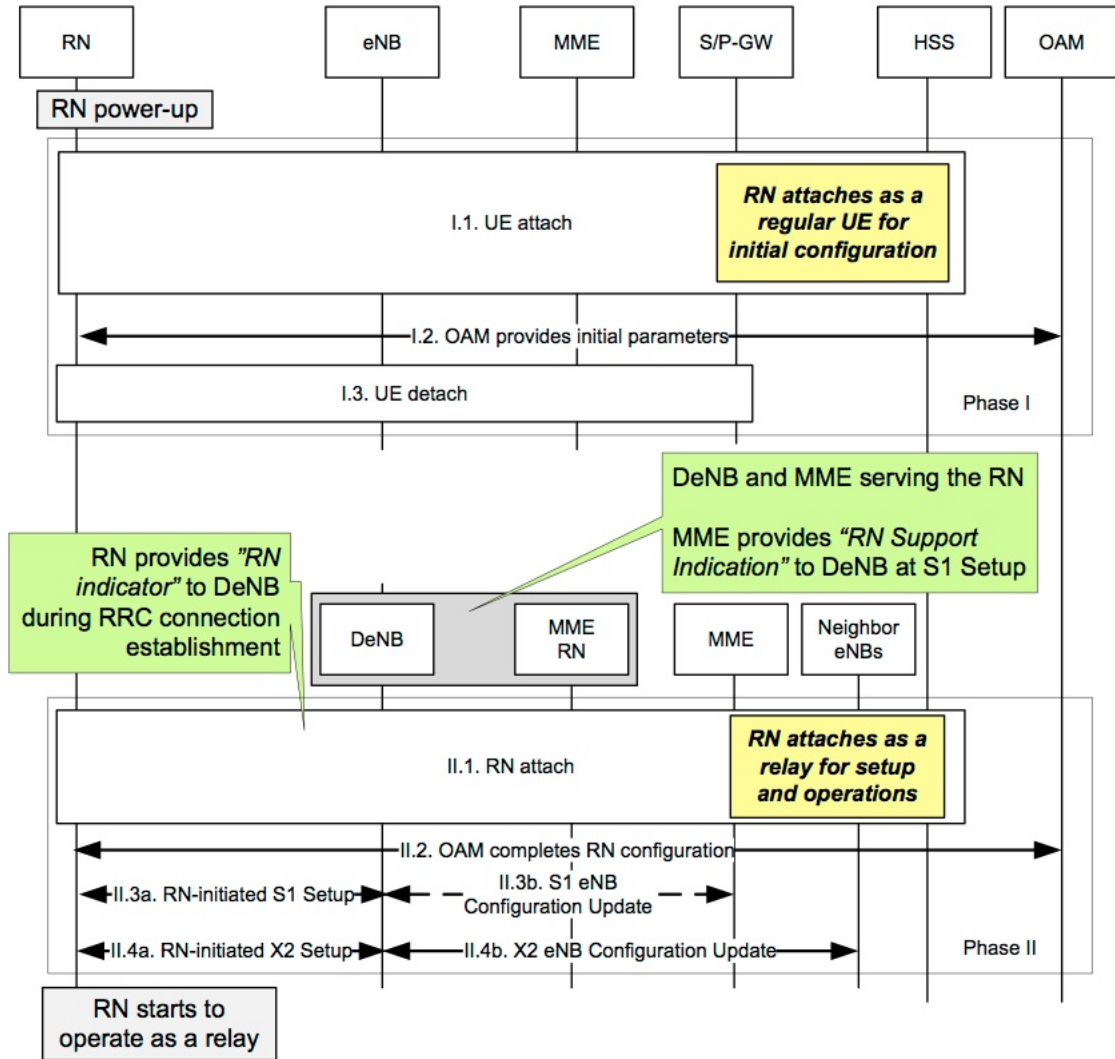

Figure 13: Relay Startup Procedure, source [6]

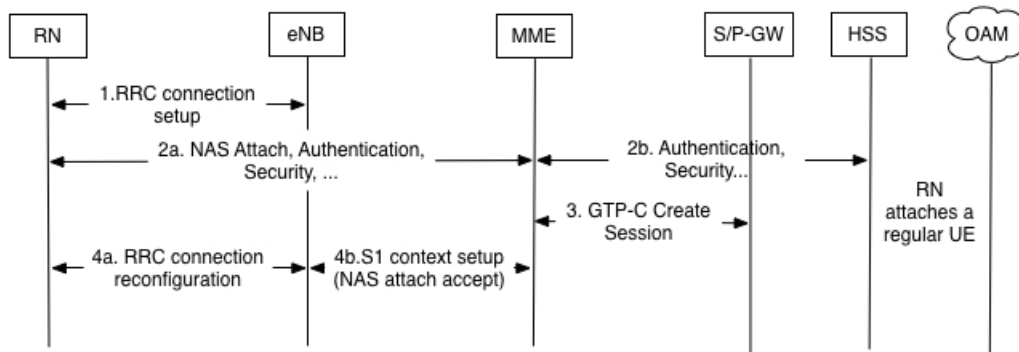

Figure 14: Relay Attaches as a regular UE

in the DeNB, within the Initial UE Message, to an MME supporting RN functionality. The MME obtains the subscription data from the HSS to verify whether the relay node is allowed to join in the network. If not, the RRC connection is released. After the DeNB initiates setup of bearer for S1/X2, the RN initiates the setup of S1 and X2 associations with the DeNB. After the S1 setup, the DeNB performs the S1 eNB Configuration Update procedure. After the X2 setup, the DeNB performs the X2 eNB Configuration Update procedure to update the cell information. The details of RN attach as a relay node are shown in Figure 15. The MME in Figure 15 refers to the MME supporting RN. The DeNB appears as an MME, an eNB and an S-GW to the relay.

### 3.5 Embedded UE Attach Procedure

There are two cases regarding to UE attach procedure in relay scenario. The first case is UE initially attaches to the relay when startup, the other one is UE already attaches to an eNodeB after startup, now it needs to attach to a relay after cell re-selection in RRC\_IDLE state.

In the first case the establishment of the UE-associated logical S1-connection towards the core network is performed due to an RRC connection establishment triggered by a Relay Node. The initial attach of a UE connecting via a relay node is shown in Figure 16. The procedure corresponds to the legacy attach mechanism.

1. First after cell selection and random access, the embedded UE initiates attach process by transmitting an attach request message with RRC parameters to the relay.

2. The relay forwards attach request message to the MME (serving the UE) in S1-MME control message. And the S1 signaling message goes via the proxy

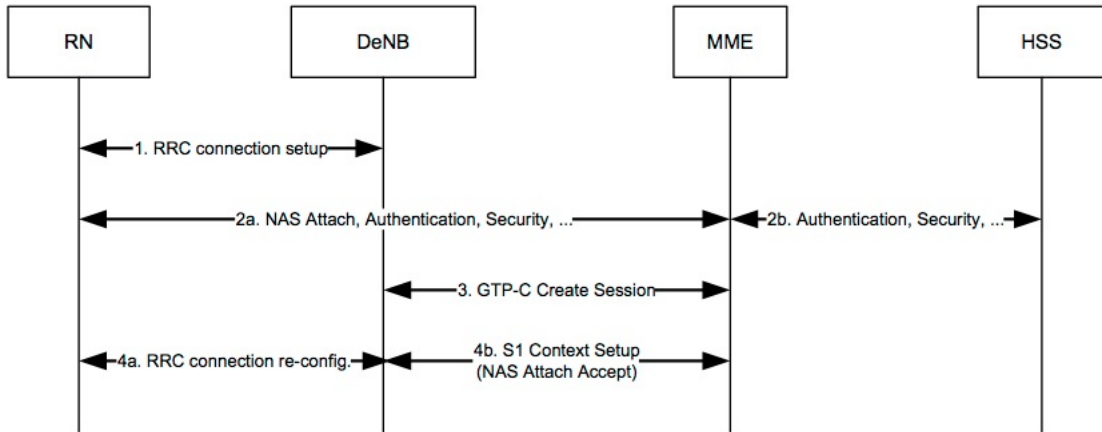

Figure 15: Relay Attaches as a relay node, source [6]

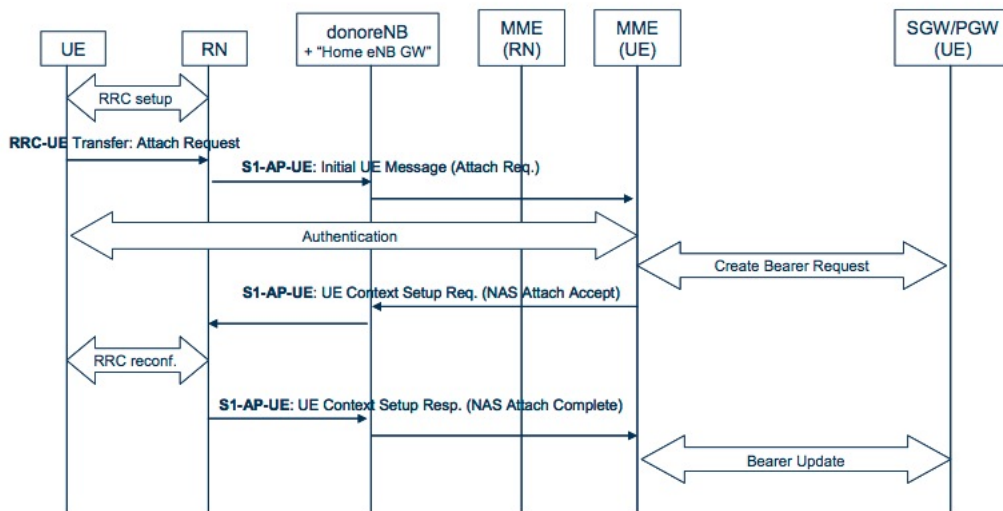

Figure 16: Embedded UE initial attach procedure via a relay node, source [7]

functionality of the donor eNB.

3. The MME selects the S-GW through S-GW selection function and allocates an EPS bearer Identity for default bearer associated with UE. Then it sends create session request message to the S-GW.

4. The S-GW creates new entry in its EPS bearer table and sends create session request to P-GW. After this step S-GW buffers downlink packets it receives from P-GW without sending downlink data notification to the MME until it receives modify bearer request message.

5. The P-GW creates a new entry in its EPS Bearer context table and generates a charging ID. The P-GW returns create session response message to the S-GW.

6. The S-GW returns create session response to the MME (serving the UE).

7. The MME sends an Attach accept message to the donor eNodeB. The donor eNodeB forwards it to the relay. This message is contained in S1-MME control message Initial Context setup request.

8. The relay sends Radio Resource Control Configuration message to the UE, the UE sends RRC configuration complete message to the relay.

9. The relay sends initial context setup response to the MME (serving the UE).

10. The UE sends direct message to the relay which includes Attach complete message.

11. The relay forwards the Attach Complete message to the MME (serving the UE).

12. Upon reception of both Initial Context Setup response message and Attach Complete Message , the MME (serving the UE) sends Modify Bearer Request to the S-GW.

13. The P-GW acknowledges by sending Modify Bearer Response to the S-GW. This Completes UE initial Attcach Procedure. The data buffered at S-GW can be sent to the UE.

The second case belongs to the category of LTE mobility in RRC\_IDLE. All the LTE mobility procedures in RRC\_IDLE state are performed autonomously within the UE. When the UE has powered on, it selects a PLMN and searches for a suitable cell to camp on. While camping on the chosen cell, the UE acquires the broadcast system information and registers its presence in the tracking area. After these steps, the UE can receive paging information. When camped on a cell, the UE regularly searches if there is a better cell according to the cell reselection criteria. If a better cell found, that cell is selected. In this case the relay node is selected, the UE verifies the relay's accessibility. The UE decodes relevant broadcast information of relay node and updates tracking area if necessary.

## 3.6 Handover Procedure

### 3.6.1 Handover from relay to eNodeB

In RRC\_CONNECTED, the E-UTRAN decides which cell a UE should handover in order to maintain the radio link. In release 11, relays are fixed, the mobility of relay node itself is not supported. The handover between relay nodes can be done within one donor eNodeB or between two donor eNodeBs. The handover procedure with relay nodes is similar to the handover between two sectors (intra donor eNodeB case) or the handover between two eNodeBs (inter donor eNodeB case). The downlink data arriving in the source relay node is forwarded from the source relay node to the target node during the handover process. The handover can be categorized into two cases, from relay to eNodeB or from eNodeB to relay.

The procedure of an X2 handover, where a UE under a relay make a handover to an eNodeB (donor or non-donor eNodeB) is shown in Figure 17. The similar procedure would apply in case of the UE making a handover to another relay node.

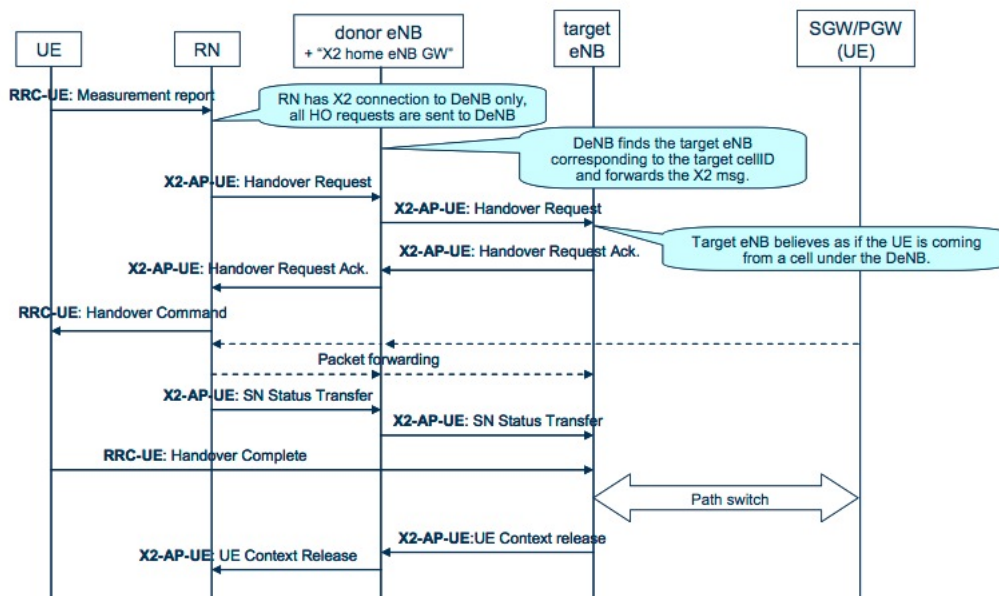

Figure 17: X2 handover from relay to target eNodeB, source [7]

From Figure 17 we can see, based on UE measurement report, the relay node decides whether to initiate a handover or not. If yes, the relay node selects a target cell. Then the relay node sends the Handover Request message to the donor eNodeB. The donor eNodeB finds the target eNodeB from the message

and forwards the X2 message towards the target eNodeB. After the reception of the handover request ACK message, the relay node sends a handover command to the UE. The UE then detaches from the relay node and starts synchronizing with the target eNodeB. Meanwhile forwarding tunnels are established from the relay node via the donor eNodeB to the target eNodeB. The buffered packets are forwarded from the relay to the target eNodeB which buffers them until the handover is complete. The MME is only informed at the end of the handover procedure once the handover is successful, and then triggers the path switch. The release of resources at the source side is directly triggered from the target eNodeB. The details of the release procedure please refers to appendix.

### 3.6.2 Handover from eNodeB to relay

In the case of handover from eNodeB to relay, its procedure is the same like handover from source eNodeB to target eNodeB. From the view of UE, relay appears like an eNodeB. The UE reports its measurement to source eNB, the source eNB decides to handover to relay node. Then the handover execution stage is entered, handover request is sent to relay through donor eNodeB. If the relay is able to admit the UE, a message is sent to the UE to initiate the handover. Downlink data arriving at the source eNodeB to the UE are forwarded to the relay. The simplified procedure is shown in Figure 18.

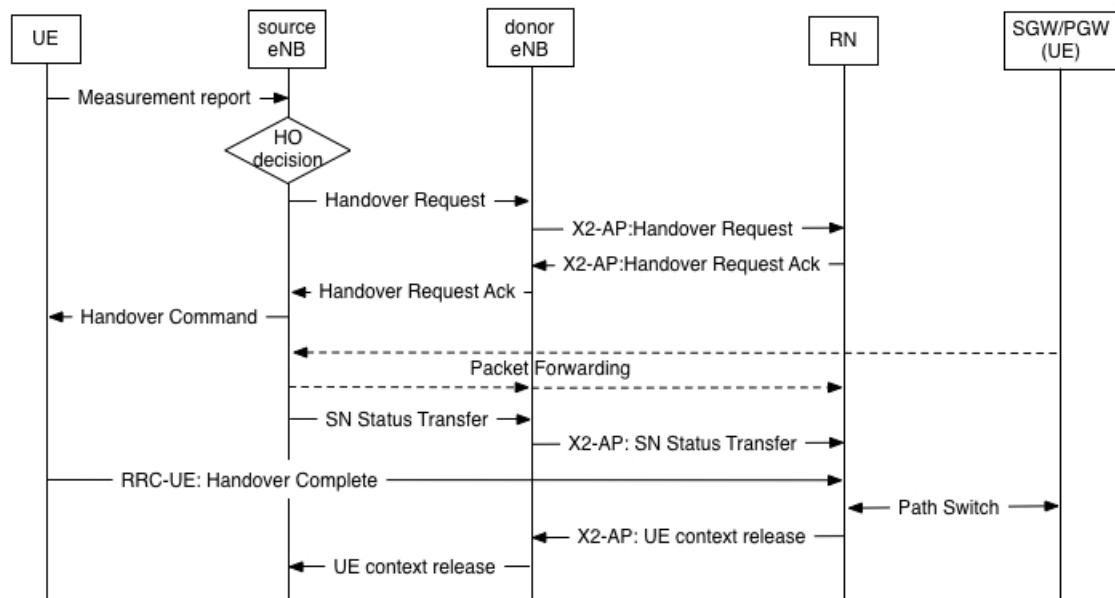

Figure 18: Handover from source eNodeB to target relay



Relay only has X2 connection to donor eNodeB, so all signaling messages are sent to relay by X2-AP interface. This handover case is based on X2 interface, the handover is directly performed between source eNodeB and relay, which can make the process quick. Once the handover is complete, the MME is informed and the path switch is triggered.

### 3.7 S1 interface relations

The control plane protocol stack for relay is shown in Figure 12. The S1-AP messages are sent between the MME and the DeNB, and between the DeNB and the RN. The S1 interface relations and signaling connections are shown in figure 19.

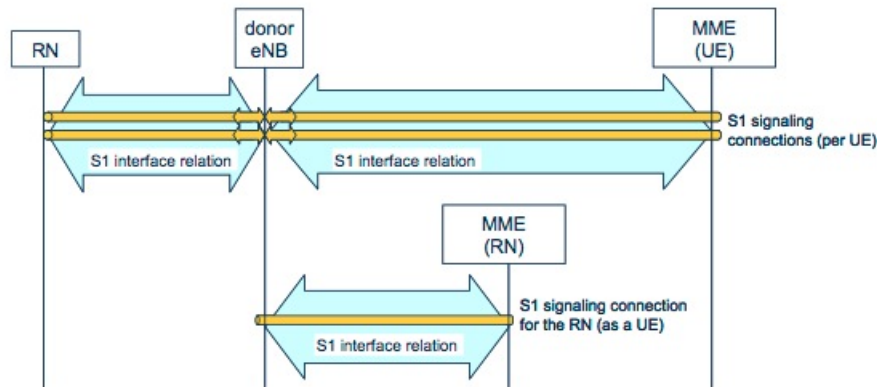

Figure 19: S1 interface relations and signaling connections, source [7]

From Figure 19, we can see there is only one S1 interface between the RN and the donor eNodeB. The RN maintains one S1 interface to the DeNB. Also there is one S1 interface between the donor eNodeB and the MME (serving the UE). The donor eNodeB maintains one interface to each MME in the respective MME pool. Note that there is an S1 signaling connection for management corresponding to the RN from the donor eNodeB to the MME that serves the RN. As is indicated by the arrows in the figure, when the donor eNodeB receives the S1-AP messages, it translates the UE IDs between the two interfaces through modifying the S1-AP UE IDs in the message.

## 4 Conclusion

This document gives a general review of architectures and protocols related to relay. Some procedures, such as relay startup procedure, embedded UE attach

procedure and handover procedure, have been discussed. The issues in this document are related to fixed relay, but they can be used as a reference for mobile relay in future study.

## Acknowledgment

This work was performed within project SYSTUF, which is subsidized by the french ministry of Industry in the framework of the AMI ITS program.

## References

- [1] Stefanis Sesia, Issam Toufik, Matthew Baker, *LTE The UMTS Long Term Evolution, From Theory to Practice*, Wiley, 2009.
- [2] Erik Dahlman, Stefan Parkvall, Johan Skold, *4G LTE/LTE-Advanced for Mobile Broadband*, Elsevier, 2011.
- [3] Xavier Lagrange, *LTE-4G*, telecom-bretagne, 2010.
- [4] Xavier Lagrange, *LTE relays and overview of Systuf Project*, telecom-bretagne, 2013.
- [5] 3GPP TS 36.413 (December 2012) Evolved Universal Terrestrial Radio Access (E-UTRA); S1 Application Protocol (S1AP) (Release 11).
- [6] 3GPP TS 36.300 (March 2013) Evolved Universal Terrestrial Radio Access (E-UTRA) and Evolved Universal Terrestrial Radio Access Network (E-UTRAN); Overall description; Stage 2 (Release 11).
- [7] 3GPP TR 36.806 (March 2010) Evolved Universal Terrestrial Radio Access (E-UTRA); Relay architectures for E-UTRA (LTE-Advanced) (Release 9)
- [8] 3GPP TS 36.423 (March 2013) Evolved Universal Terrestrial Radio Access (E-UTRA); X2 application protocol (X2AP) (Release 11).

**Campus de Brest**

Technopole Brest-Iroise  
CS 83818  
29238 Brest Cedex 3  
France  
+33 (0)2 29 00 11 11

**Campus de Rennes**

2, rue de la Chataigneraie  
CS 17607  
35576 Cesson Sevigne Cedex  
France  
+33 (0)2 99 12 70 00

**Campus de Toulouse**

10, avenue Edouard Belin  
BP 44004  
31028 Toulouse Cedex 04  
France  
+33 (0)5 61 33 83 65

[www.telecom-bretagne.eu](http://www.telecom-bretagne.eu)

©Telecom Bretagne, 2013  
Imprime a Telecom Bretagne  
Depot legal : Mai 2013  
ISSN : 1255-2275

