



**HAL**  
open science

# Temporal Logic in Natural Language Processing

Djallel Bouneffouf

► **To cite this version:**

Djallel Bouneffouf. Temporal Logic in Natural Language Processing. [Research Report] IRIT. 2013.  
hal-00820439

**HAL Id: hal-00820439**

**<https://hal.science/hal-00820439>**

Submitted on 7 Apr 2014

**HAL** is a multi-disciplinary open access archive for the deposit and dissemination of scientific research documents, whether they are published or not. The documents may come from teaching and research institutions in France or abroad, or from public or private research centers.

L'archive ouverte pluridisciplinaire **HAL**, est destinée au dépôt et à la diffusion de documents scientifiques de niveau recherche, publiés ou non, émanant des établissements d'enseignement et de recherche français ou étrangers, des laboratoires publics ou privés.

# Temporal Logic and its Applications in Natural Language Processing

Djallel Bouneffouf

Department of Computer Science, Telecom SudParis, UMR CNRS Samovar, 91011 Evry  
Cedex, France

{Djallel.Bouneffouf}@it-sudparis.eu

**Abstract.** In this paper, we clarify some linguistic concepts, studying the different levels of representation and processing of linguistic utterances. We also illustrated with some work the different types of existing temporal inferences; we noted that this work is based on improved detection of existing temporal relations between events and temporal expressions.

**Keywords:** Temporal Logic, Natural language processing, Inference engine, Machine learning, Artificial intelligence

## 1 Introduction

The word "time" includes several meanings in French, and it is necessary for the understanding to distinguish grammatical tense of the notional time. The second is represented by a logic and infinite straight line with this marking a point between the past and the future. The grammatical tense refers to linguistic markers used to express the notional time in language (imperfect, the present tense, etc. ....).

In what follows we will explore these two concepts of time, from the point of view logic with these representations (point structure, interval structure, event and Allen) then the language point of view.

We conclude with a study of the temporal inference drawn by one of the most successful groups in the area.

## 2 The point structure

The concept of time is commonly connected to the notion of point or moment on a time axis. Points make it possible to use the structures of numbers (integers, rational or real). This design is widely used in modeling phenomena evolving over time.

This temporal structure should be handled with a logical language, the logic of time, historically linked to the development of modal logics. It is based on the usual logical connectors ( $\wedge$ ,  $\vee$ ,  $\neg$ ,  $\Rightarrow$ ,  $\Leftrightarrow$ ) And temporal operators P (past) and F (future). Thus, if

the action of singing performed by John is denoted by p, we have the following representations:

- John sings: p
- John sang Pp
- John sing: Fp
- John sang: Ppp (we place ourselves in the past to a point past itself)
- John has sung FPP

These formulas will be enriched with new similar to those used in modal logic (Bras, 1990) operators.

All logic derived from the logical time is based on an ontology of points. We will now look at intervals of ontologies.

### 3 The structure of intervals

From a philosophical point of view, it seems that the concept of free time point does not correspond to reality:

From a linguistic point of view, it is even more obvious that point feature is not well suited for the expression of the time reference. Even the so-called ad hoc expressions refer to extensive, as in the following examples periods:

At six o'clock, Harry left his office.

A gap structure is defined by  $\langle I, <, \subseteq \rangle$ , With I a non-empty set of temporal entities, relations of precedence ( $<$ ) and inclusion ( $\subseteq$ ). Here are some properties of this structure:

$\subseteq$  is a partial order, it is in effect:

Reflexive:  $(\forall x \in I) x \subseteq x$ .

Antisymmetric:  $(\forall x \in I) (\forall y \in I) (x \subseteq y \wedge y \subseteq x \Rightarrow x = y)$ .

Transitive:  $(\forall x \in I) (\forall y \in I) (x \subseteq y \wedge y \subseteq z \Rightarrow x \subseteq z)$ .

We can also replace the relationship (the relationship O (overlap) which says that two events have a common part, and defined with respect to inclusion:

$$xOy \Leftrightarrow (\exists z) (z \subseteq x \wedge z \subseteq y)$$

The introduction of temporal logic based on semantic intervals lead to relatively complex results, it is not necessary to describe here.

Criticisms were directed semantic intervals, especially with regard to the difficulty of defining the truth of a proposition (true for all intervals? At least one of them?). These problems have led to the need to develop a more comprehensive and complete entity.

### 4 Event Structure

The event is a new primitive entity, non-zero and finite duration, intuitively corresponding to fragments of our perception of the world. For linguists to philosophers, logicians and specialists in artificial intelligence, the tendency is to prefer the events at intervals because the events are not only temporal structure in scope but also space.

Davidson has proposed to treat events as objects, adding to all individuals of a model, a set of events, for example, the sentence Mary loves Paul is no longer represented by love (Paul Marie), but:  
Love (e, Paul, Mary)

An event structure is defined by the Kamp  $\langle E, \alpha, O \rangle$ , triplet, where E is a set of basic entities non null,  $\alpha$  is the precedence relation, and the overlapping relationship O  $e_1 O e_2$  then if a of  $e_1$  at least took place along  $e_2$ .

$\alpha$  is asymmetric:  $(e_1 \alpha e_2) \Rightarrow (e_2 \alpha e_1)$

$\alpha$  is transitive:  $(e_1 \alpha e_2) \wedge (e_2 \alpha e_3) \Rightarrow (e_1 \alpha e_3)$

O is symmetrical:  $(e_1 O e_2) \Rightarrow (e_2 O e_1)$

O is reflexive:  $(e_1 O e_2)$

Principle of separation:  $(e_1 \alpha e_2) \Rightarrow \neg (e_1 O e_2)$

Mixed transitive  $(e_1 \alpha e_2) \wedge (e_2 O e_3) \wedge (e_3 \alpha e_4) \Rightarrow (e_1 \alpha e_4)$

Principle of linearity:  $(e_1 \alpha e_2) (e_1 O e_2) (e_2 \alpha e_1)$

These minimum requirements are dictated by intuition when we have events and relationships between them.

We presented three ontologies (dot structures, interval structures and event structures). It is essential to separate the temporal level (point and interval) level on the experience of the world (events). While the relationships defined in the event structures are temporal relations, events are also experiences, "facts" that are taking place and determine the structure of time.

This is why we can say that the logic of Allen can relate the two.

## 5 Allen's theory

According to Allen, two intervals can be linked by the following 13 primitive relations (Bras, 1990). Where X and Y are terms of types of time intervals (called "inverse relationship" the corresponding relationship between Y and X):

Relationship	Symbol	Symbol inverse relationship
X before Y	<	>
X equals Y	=	=
X Meets Y	M	Mi

X overlaps Y	O	Oi
X during Y	D	Di
X starts Y	S	If
X finishes Y	F	Fi

**Fig. 1.** Table 2.1: Allen relations

Relationships are mutually exclusive: one relationship is possible between two intervals.

It is possible to compose relations. Thus, the transitivity of the relations between intervals is defined by:

$$\forall I \forall j \forall k ((i < j) \wedge (j < k) \Rightarrow i < k)$$

$$\forall I \forall j \forall k ((I \text{ m } j) \wedge (j \text{ d } k) \Rightarrow (I \text{ o } k) \vee (I \text{ d } k) \vee (I \text{ s } k))$$

There are 169 transitive relations of this type.

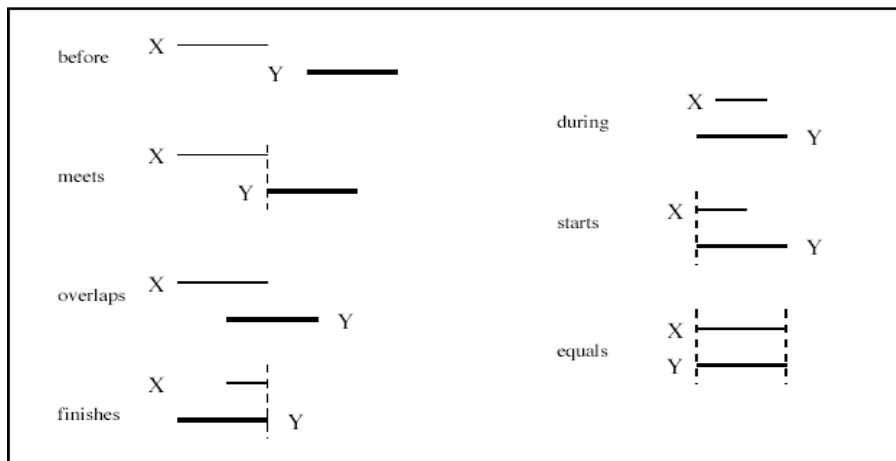

**Fig. 2.** Representation of Allen Relations

Two intervals can be connected by a primitive relationship, but also a complex relationship, it is possible to represent an incomplete understanding of the relationship.

A knowledge of the time interval set may be represented by a network of constraints.

It is a directed graph whose nodes represent intervals and whose edges are labeled with the relationship between intervals.

## 6 Time in the language

What distinguishes the language of the time with other notions of time? "What the language of a particular time is that it is organically linked to the exercise of speech, it is defined and ordered as a function of speech. This time its center -. Center at both axial and generator - in this instance of the word "(Benveniste, 1974). The speech establishes a now moment of enunciation. As opposed to now, when we create a. This is now the basis for opposition to the language.

### 6.1 Model Reichenbach

Reichenbach proposed to model the semantics, the following three benchmarks tenses:

E is the time of the occurrence

S the time of utterance or speech (Speech Time)

The reference time R

Possible relations between landmarks are the relationship of simultaneity) noted ",", and the precedence relation denoted "\_". The novelty lies in the addition of a time reference, which allows to take into account certain compounds time. Thus, the representation of some tenses with the Reichenbach model is as follows:

I live just past Paul E\_R\_S

More-than-perfect I saw Paul E\_R\_S

Future I see Paul S\_E, R

Future I have seen Paul S\_E\_R

### 6.2 Temporal adverbial

Is an adverbial element (word or group of words) with a similar function to that of an adverb or adverbial, that is to say it changes the verb to which it is attached (Charolles 1997). We can delete it without making the syntax or semantics of the incorrect sentence. Thus the passages highlighted the following examples are temporal adverbial function:

Paul arrives tomorrow.

Marie returned to five hours.

We can distinguish:

Adverbial time reference whose role is to express the location of an event in time tomorrow.

Adverbial of time: one hour in three days

Adverbial of time: hang an hour.

Adverbial frequency: often, every month.

Iterative adverbial: three times, several times.

Adverbial quantification: always, sometimes.

The presuppositional adverbial: again, already.

## 7 The temporal inference

If the annotation markers of time in the speech are the subject of several research topics, the study of temporal inference and its applications are still in their infancy. This problem begins to generate computational linguistics work related issues that represent the temporal information among other information for research and Q systems.

With the exploration of this new field in natural language processing, temporal inference allows us to establish temporal relations existing between events in a text, to detect existing relations between temporal expressions and also the relationship between temporal expressions and events.

In what follows we present one of the most advanced research in the field.

### 7.1 The work of the group Human Language Technology Research Institute (HLTRI) on temporal inference:

HLTRI is a research group working on temporal inference. He is also a member of the founding organization of language (TimeML1) EstTimeML which is a robust specification language for events and temporal expressions in natural language. a language of events and temporal expressions in natural language specification. It is designed to address four problems in event and temporal speech markup:

To study the temporal inference in natural language, the group (HLTRI) established a large corpus of questions and answers that are based on research of temporal information.

The questions are annotated as follows:

- Temporal Expressions TIMEX3 annotated by the tag.
- The EVENT tag is an event.
- LINK is a tag that encodes the relationship between temporal elements.

To discover the temporal relationships between events in a text, the group used the graph.

The nodes of the graph are represented by events and arcs between nodes are either TLink relationships, or slink ALink.

To classify events in a single text, it uses three ALINK, TLink, and slink between the events of two different texts ties uses only TLink module.

- TLink representing the temporal relationships between events or between an event and a time expression.

- Slink or subordinate relationship is used to introduce contexts and relationships between events.

---

<sup>1</sup> TimeML has-been Developed in the context of three workshops and AQUAINT projects. TimeML was developed in three workshops and AQUAINT projects. The 2002

- ALink or aspectual relationship, representing the relationship between aspectual Eventement and its argument (in general this is another event).

To get all possible events between the two texts temporal relations, the group has developed a module temporal inference.

From the different links TLink, ALINK and between temporal expressions and events SLINK the module infers new previously undetected links. For this, the group has defined several inference rules that are listed below:

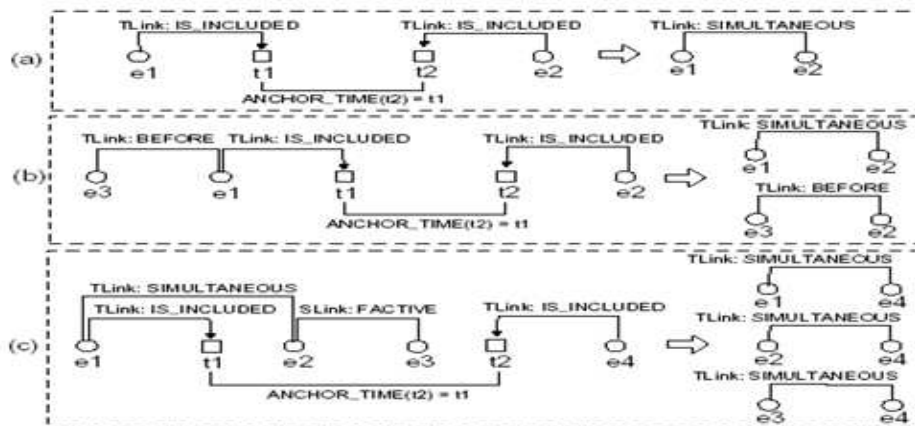

Fig. 3. Temporal inference rules

Specifically the module the following steps:

Step 1: find T1 and T2 two temporal expressions in the sentence or in adjacent sentences.

Step 2: Search for events E1 and E2 bound to T1 and T2 respectively.

Step 3: Find a link between E1 and other events CE1 relationship.

Step 4: Find CE2 relationship link between E2 and other events.

Step5: Use temporal inference between CE1 and CE2.



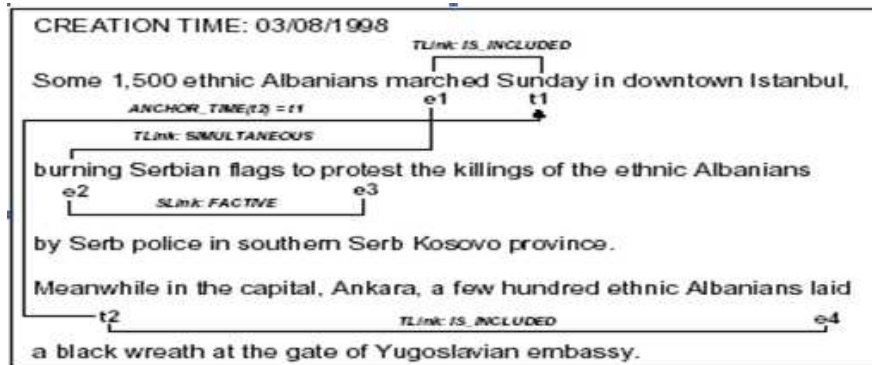

Fig. 4. Application of the rules of inference of an example of the RTE corpus

When applying the procedure to the example shown in Figure 2.3 the module the following steps:

Step 1: find the t1 and t2 temporal expressions.

Step 2: e1 and e4 related to t1 and t2 with TLink events is\_includes.

Step 3: detecting the sequence of events (e1, e2, e3).

Step 5: T1 and T2 are linked (by ANCHORTIME (t2) = t1), which means that e1, e2, e3 and e4 are simultaneous.

This group focused on the deduction of new relationships between events. This study on temporal inference has established several rules of inference linking events and temporal expressions.

## 8 Conclusion

In this paper we explored the temporal logic and its applications in the natural language processing. We have also shown the work of the group (HLTRI) the different types of existing temporal inferences; we noticed that this group is based on the improvement of existing detections temporal relations between events and temporal expressions. We were inspired by the work of our approach to develop the body and design our inferences.

## References

1. Bouneffouf, D. Role of temporal inference in the recognition of textual inference. arXiv preprint arXiv: 1302.5645 (2013).
2. Bouneffouf, D. Role de l'inference temporelle dans la reconnaissance de l'inference textuelle, . thesis, Universite des Sciences et de la Technologie Houari Boumediene 2008
3. Baker, Charles J. Fillmore, and John B. Lowe. 1998. The Berkeley FrameNet project. In Proceedings of the COLING-ACL, Montreal.
4. Myriam Bras. Computational Structural Temporal Speech. PhD thesis, IRIT, 1990.

5. Emile Benveniste, *Problems in General Linguistics*. Paris, Gallimard, vol. II.
6. Charolles Mr. "L" discourse framing - universe, fields, areas and spaces, *"Cahier de recherche linguistics*, 6, p. 1-73. 1997.
7. Moldovan and Rus Logic Forms Can Be Utilized by a wide variety.2001.
8. P. Miller. 1995. "Notes on phonology and orthography in several Katuic Mon-Khmer groups in Northeast Thailand." *Mon-Khmer Studies* 24: 27-51.
9. Pierre Nugues. *An Introduction to Language Processing with Perl and Prolog*. Springer Verlag, 2006.
10. E. Nyberg, T.Mitamura, J. Carbonell, J. Callan, K. Collins-Thompson, K Czuba, Duggan, L. Hiyakumoto, N. Hu, Y. Huang, J. Ko, L.V. Lita S.Muratagh and V. Pedro. The JAVELIN Question-Answering System at TREC 2002. In proceeding of the 11th
11. Text Retrieval Conference (TREC-11), 2002.
12. Paul Kiparsky and Carol Kiparsky. In Manfred Bierwisch and Karl Erich Heidolph, editors, *Progress in Linguistics. A Collection of Papers*, pages 143-173. Mouton, Paris.
13. A. Rodrigo, A. Pe ~ nas, J. Herrera and F. Verdejo .. The Effect of Entity Recognition on Answer Validation. In *Lecture Notes in Computer Science*. In press 2007.
14. workshop on recognizing textual entailment, 2005.
15. Mr. Venhagen, I. Mani, R. Sauri, R. Knippen, J. Littman and J. Pustejovsky. 2005. Automating Temporal Annotation With TARSQI. In *Proceedings of ACL 2005*. demo session.