



**HAL**  
open science

## Fault detection, isolation and estimation for Takagi-Sugeno nonlinear systems

Dalil Ichalal, Benoît Marx, José Ragot, Didier Maquin

► **To cite this version:**

Dalil Ichalal, Benoît Marx, José Ragot, Didier Maquin. Fault detection, isolation and estimation for Takagi-Sugeno nonlinear systems. *Journal of The Franklin Institute*, 2014, 351 (7), pp.3651-3676. 10.1016/j.jfranklin.2013.04.012 . hal-00809844

**HAL Id: hal-00809844**

**<https://hal.science/hal-00809844v1>**

Submitted on 27 Feb 2023

**HAL** is a multi-disciplinary open access archive for the deposit and dissemination of scientific research documents, whether they are published or not. The documents may come from teaching and research institutions in France or abroad, or from public or private research centers.

L'archive ouverte pluridisciplinaire **HAL**, est destinée au dépôt et à la diffusion de documents scientifiques de niveau recherche, publiés ou non, émanant des établissements d'enseignement et de recherche français ou étrangers, des laboratoires publics ou privés.



Distributed under a Creative Commons Attribution - NonCommercial - NoDerivatives 4.0  
International License

# Fault detection, isolation and estimation for Takagi-Sugeno nonlinear systems

Dalil Ichalal\*, Benoît Marx<sup>†,‡</sup>, José Ragot<sup>†,‡</sup>, and Didier Maquin<sup>†,‡</sup>

\* Laboratoire d'Informatique, Biologie Intégrative et Systèmes Complexes (IBISC),  
Université d'Evry Val d'Essonne, 40, rue de Pelvoux, Courcouronnes, 91080 Cedex, France  
dalil.ichalal@ibisc.univ-evry.fr

† Université de Lorraine, Centre de Recherche en Automatique de Nancy (CRAN),  
UMR 7039, 2 avenue de la Forêt de Haye, 54516 Vandoeuvre-lès-Nancy, France

‡ CNRS, CRAN, UMR 7039, France

e-mail: {benoit.marx, jose.ragot, didier.maquin}@univ-lorraine.fr

December 29, 2012

## Abstract

This article is dedicated to the problem of fault detection, isolation and estimation for nonlinear systems described by a Takagi-Sugeno (T-S) model. One of the interests of this type of models is the possibility to extend some tools and methods from the linear system case to the nonlinear one. The principle of the proposed strategy is to transform the problem of simultaneously minimizing the perturbation effect and maximizing the fault effect, on the residual vector, in a simple problem of  $\mathcal{L}_2$ -norm minimization. A linear system is used to define the ideal response of the residual signal to the fault. Then the aim is to synthesize a residual generator that both minimizes the difference between real and ideal responses and the influence of the disturbance. The minimization problem is formulated by using the bounded real lemma (BRL) and linear matrix inequality (LMI) formalism. After studying the general framework, a special case of systems with actuator and sensor faults is considered where the fault incidence matrix is not full column rank. Simulation examples are given to illustrate the proposed method. Finally, Polya's theorem is used to reduce the conservatism of the proposed result. The obtained relaxation is also illustrated by a numerical example.

Takagi-Sugeno systems, robust fault diagnosis, robust fault estimation,  $\mathcal{L}_2$  approach, LMIs.

## 1 Introduction

Diagnosis issues are becoming very important to ensure a good supervision of systems and guarantee the safety of human operators and equipments even if system complexity increases. That is why, in the last decades, many theories and methods have been developed for linear systems in the fields of fault diagnosis [32, 11, 7] and fault tolerant control [17, 20, 39]. Unfortunately, the linearity assumption of

a system is generally a local property, i.e. a linear model describes the behavior of a real system only around a single operating point. Furthermore, when a fault occurs, the operating point of the system may change, therefore, the considered linear model is no longer valid. In order to enlarge the operating range of the model, it is important to take into account the nonlinearities in the modeling tasks. The obtained models are more accurate than linear ones but are obviously also harder to deal with. Indeed, due to this complexity, no unified results for nonlinear system fault diagnosis or fault tolerant control are available so far. Consequently, it leads to work on specific model classes, for example, Lipschitz systems [45], switched systems [46], LPV systems, bilinear systems, etc.

Among the several classes of nonlinear systems, Takagi-Sugeno (T-S) models have been introduced in [38]. Roughly speaking, a T-S model is made up of a set of linear sub-models and an interpolation mechanism based on nonlinear weighting functions. The interest of this structure is the property of “universal approximator”. Any nonlinear behavior can be then approximated with a given accuracy with a T-S model. A second important property of this type of models is the convex sum property of the weighting functions which allows to extend some of tools and methods developed for linear systems.

The T-S models have been extensively studied in the last decades. Modeling and identification are treated in [8, 31, 30]. The principal methods to obtain a T-S model are the linearization of the system trajectory around different operating points and the use of optimization techniques to minimize the identification error. Secondly, for more complex systems, a nonlinear analytic model is often difficult to elaborate, so the black box approach has been used in order to identify the system parameters by different optimization methods. Finally, if an analytical model exists, the sector nonlinearity approach can be used [42, 43]. The interest of this last method is that the obtained model exactly represents the original nonlinear model. This model may be difficult to study due to the dependence of the weighting functions on the system state which is often not fully measurable. Nevertheless an adequate choice of the model rewriting can be made in order to ease its use for control or diagnosis [26, 27]. In order to reduce the complexity of T-S models, some works are undertaken recently leading to a reduced order model which approximates a nonlinear T-S model, in discrete-time domain, by minimizing an  $\mathcal{H}_\infty$  criterion [22].

Stability analysis and stabilization of nonlinear T-S systems are studied in [43, 42, 41, 5, 21, 12, 9], where different approaches are used. Among these approaches, one can cite the use of the Lyapunov theory and the formulation of the stability conditions in terms of linear matrix inequalities (LMI). Quadratic stability, where a common Lyapunov matrix is sought, has been studied in [42] but it may be too conservative to obtain a numerical solution. Then, the polyquadratic and the non-quadratic approaches have been developed in [40, 19]. These approaches are extended in [1, 2, 3, 47, 13, 16, 37] to state and unknown input observer design and filter design. These observers are then used for fault diagnosis in [6, 13, 23, 2, 48, 28, 14].

Several techniques for fault detection and diagnosis have been proposed in the literature (for more details, the reader can refer to the books [11, 17, 7]). In the domain of T-S systems, some approaches are generalized from linear domain. In [6] (resp. [13]), diagnosis for T-S systems is dealt with but only

actuator (resp. sensor) fault was considered and the system output was linear. Similar results as those presented in this paper were established in [36] for linear systems with structured uncertainties using the standard  $\mathcal{H}_\infty$  approach. In the present paper, both actuator and sensor faults are considered and the system output is nonlinear with regard to the state and the exogenous signals. In [23, 28], both sensor and actuator faults are envisaged, but the residual response is not designed in order to match a prescribed one. The shaping of the residual response is treated in [35, 24] for linear systems. In [48], A similar problem is aimed in the discrete time case in stochastic framework, for systems with intermittent measurements. Here the residual response shaping is proposed for continuous time nonlinear systems.

In this paper, a robust residual generator is proposed in order to achieve the tasks of fault detection, isolation and estimation. The main objective is to extend the method of fault diagnosis based on  $\mathcal{H}_\infty$  control framework, developed for linear systems in [36, 35, 24] including a reference model shaping the residual signals in order to enhance fault detection, isolation and estimation [24]. First, the problem of disturbance attenuation and fault influence maximization is reduced to a matching problem. The residual generator is built to provide a response to the fault that matches the output of a reference model virtually fed with the fault signal. This reference model corresponds to the desired response of the residual to the fault. The matching is quantified by the  $\mathcal{L}_2$ -gain from the exogenous signals to the difference between the residual and the output of the reference model. In other words, the objective of this work is to provide a residual generator delivering signals which are sensitive to an occurring fault and insensitive to other faults and perturbations, so, each residual signal detects one fault, thus, the structured residual vector provides fault detection and isolation. The minimization of this  $\mathcal{L}_2$ -gain can be recast in an optimization problem under LMI constraints and solved with dedicated software. The detection, isolation and estimation are performed in a unified way by an adequate choice of the reference model. The general case is considered and a particular attention is made for the case of rank condition deficiency which is true in actuator and sensor fault diagnosis because the fault distribution matrices are not full column rank).

This paper is organized as follows. The second section is dedicated to the problem statement; some notations are also introduced. The main result is given in the third section and a particular case of actuator and sensor faults where the distribution fault matrix of the output equation is not full column rank is treated. Two examples are given to illustrate and to discuss the effectiveness of the proposed strategy for fault diagnosis. In the fifth section, the conservatism of the previously proposed LMI conditions is reduced with the help of the Polya's theorem. This conservatism reduction is illustrated by a numerical example. The last section is devoted to some conclusions and future works.

## 2 Problem statement

Nonlinear systems are generally modeled in the following form:

$$\begin{cases} \dot{x}(t) = f(x(t), u(t)) \\ y(t) = h(x(t), u(t)) \end{cases} \quad (1)$$

where  $x(t) \in \mathbb{R}^n$  is the state vector,  $u(t) \in \mathbb{R}^{n_u}$  is the control input and  $y(t) \in \mathbb{R}^{n_y}$  represents the system output vector. The functions  $f$  and  $h$  are generally nonlinear. This mathematical model can represent any nonlinear behavior but its main disadvantage is its complexity and therefore it is not always adapted to design a controller or an observer. As explained in the previous section, the T-S formalism is suitable for observer and/or controller design for nonlinear systems.

Using identification, linearization, or the so-called sector nonlinearity transformation, a T-S model for the model (1) may be obtained under the form:

$$\begin{cases} \dot{x}(t) = \sum_{i=1}^r \mu_i(\xi(t)) (A_i x(t) + B_i u(t)) \\ y(t) = \sum_{i=1}^r \mu_i(\xi(t)) (C_i x(t) + D_i u(t)) \end{cases} \quad (2)$$

where  $A_i \in \mathbb{R}^{n \times n}$ ,  $B_i \in \mathbb{R}^{n \times n_u}$ ,  $C_i \in \mathbb{R}^{n_y \times n}$ ,  $D_i \in \mathbb{R}^{n_y \times n_u}$ . The weighing functions  $\mu_i$  are nonlinear and depend on the decision variable  $\xi(t)$  which can be measurable like  $u(t)$  or  $y(t)$  or not measurable like the system state  $x(t)$ . It can also be an external signal. The weighing functions satisfy the following so-called convex sum property:

$$\begin{cases} 0 \leq \mu_i(\xi(t)) \leq 1, \quad \forall t, \forall i = 1, \dots, r \\ \sum_{i=1}^r \mu_i(\xi(t)) = 1, \quad \forall t \end{cases} \quad (3)$$

The multiple model structure is known to be a universal approximator since it can represent, with a given accuracy, any nonlinear behavior according to an adequate number  $r$  of submodels (chap 14 of [43]). Moreover, the multiple model structure provides a mean to generalize the tools developed for linear systems to nonlinear systems due to the properties (3) and to the linearity of the submodels.

In this paper, the objective is to design a robust residual generator for nonlinear systems in order to detect, and under specific hypothesis, to isolate the faults affecting a system. Thus, the study is dedicated to the problem of fault detection, isolation and estimation for nonlinear systems described by continuous-time T-S models. Besides the faults  $f(t)$  affecting the system, it may also be subject to disturbances  $d(t)$ , thus the system is now modified as follows:

$$\begin{cases} \dot{x}(t) = \sum_{i=1}^r \mu_i(\xi(t)) (A_i x(t) + B_i u(t) + E_i d(t) + F_i f(t)) \\ y(t) = \sum_{i=1}^r \mu_i(\xi(t)) (C_i x(t) + D_i u(t) + G_i d(t) + R_i f(t)) \end{cases} \quad (4)$$

where  $E_i \in \mathbb{R}^{n \times n_d}$ ,  $F_i \in \mathbb{R}^{n \times n_f}$  and  $G_i \in \mathbb{R}^{n_y \times n_d}$ , and  $R_i \in \mathbb{R}^{n_y \times n_f}$ . In the following, the decision variable  $\xi(t)$  is assumed to be measurable. With this representation, it should be noted that both the fault and the disturbance affect the dynamic equation of the system as well as the measurement equation. However, depending on the structures of the matrices  $F_i$  and  $R_i$  it is possible to consider specific faults affecting the dynamic part and others affecting only the static part. This could be easily obtained when some columns of the previous matrices are filled up with null elements.

The input signals  $f(t)$  and  $d(t)$  belong to  $\mathcal{L}_2$  set. The  $\mathcal{L}_2$ -norm of  $u(t) \in \mathcal{L}_2$  is given by

$$\|u(t)\|_2 = \left( \int_0^{+\infty} u^T(t)u(t)dt \right)^{1/2} \quad (5)$$

Given the system (4) affected by a fault and a disturbance, the diagnosis task consists in generating a signal, namely a residual, that is mainly affected by the fault and thus can be used as a fault indicator. This residual should be made as sensitive as possible to the fault while insensitive to the disturbance in order that the fault diagnosis is robust. Ideally, in multiple faults case, the residual vector should be structured to allow fault isolation. This later point can be addressed if the transfer from the fault to the residual matches a desired response. In fact residual generation can be viewed as  $\mathcal{L}_2$ -control, since the residual generator is designed by minimizing the  $\mathcal{L}_2$ -gain from the exogenous signals (fault and disturbance) to the error between the desired and the obtained responses of the residual signal.

### 3 Residual generator design

The residual generator design for nonlinear systems described by a Takagi-Sugeno model is addressed in this section. When synthesizing a residual generator, particular detection performances are desired. A natural way for that is to define these performances using a reference model describing the desired behavior of the residuals in regard to the faults.

Let consider the T-S nonlinear system subject to disturbances, sensor and actuator faults modeled by (4). An observer-based residual generator is proposed in the following form where the residual is defined by a linear combination of the output estimation errors

$$\begin{cases} \dot{\hat{x}}(t) = \sum_{i=1}^r \mu_i(\xi(t))(A_i \hat{x}(t) + B_i u(t) + L_i(y(t) - \hat{y}(t))) \\ \hat{y}(t) = \sum_{i=1}^r \mu_i(\xi(t))(C_i \hat{x}(t) + D_i u(t)) \\ r(t) = M(y(t) - \hat{y}(t)) \end{cases} \quad (6)$$

where  $\hat{x}(t) \in \mathbb{R}^n$  is the estimated state vector and  $r(t) \in \mathbb{R}^{n_r}$  is the residual signal. The matrices  $L_i \in \mathbb{R}^{n \times n_y}$  and  $M \in \mathbb{R}^{n_r \times n_y}$  are the residual generator gains. Since the measurement  $y(t)$  in (4) is sensitive to the fault and the disturbance, it is clear that the residual is also sensitive to these quantities. Thus, in order to detect the fault despite the presence of the disturbance, the objective is to design the gains  $L_i$  and  $M$

in order to minimize the transfer from the disturbances  $d(t)$  and to maximize the transfer from the faults  $f(t)$  to the residual signal  $r(t)$ . Let us define the state estimation error  $e(t) = x(t) - \hat{x}(t)$ . Its dynamics is deduced from (4) and (6) as follows

$$\begin{cases} \dot{e}(t) = \bar{A}_{\xi\xi}e(t) + \bar{E}_{\xi\xi}d(t) + \bar{F}_{\xi\xi}f(t) \\ r(t) = \bar{C}_{\xi}e(t) + \bar{G}_{\xi}d(t) + \bar{R}_{\xi}f(t) \end{cases} \quad (7)$$

where:

$$\bar{A}_{\xi\xi} = \sum_{i=1}^r \sum_{j=1}^r \mu_i(\xi)\mu_j(\xi)(A_i - L_iC_j) \quad (8)$$

$$\bar{E}_{\xi\xi} = \sum_{i=1}^r \sum_{j=1}^r \mu_i(\xi)\mu_j(\xi)(E_i - L_iG_j) \quad (9)$$

$$\bar{F}_{\xi\xi} = \sum_{i=1}^r \sum_{j=1}^r \mu_i(\xi)\mu_j(\xi)(F_i - L_iR_j) \quad (10)$$

$$\bar{C}_{\xi} = \sum_{i=1}^r \mu_i(\xi)MC_i \quad (11)$$

$$\bar{G}_{\xi} = \sum_{i=1}^r \mu_i(\xi)MG_i \quad (12)$$

$$\bar{R}_{\xi} = \sum_{i=1}^r \mu_i(\xi)MR_i \quad (13)$$

Thus, with (7), an explicit expression of the residual  $r(t)$  depending only on the fault  $f(t)$  and the disturbance  $d(t)$  is obtained.

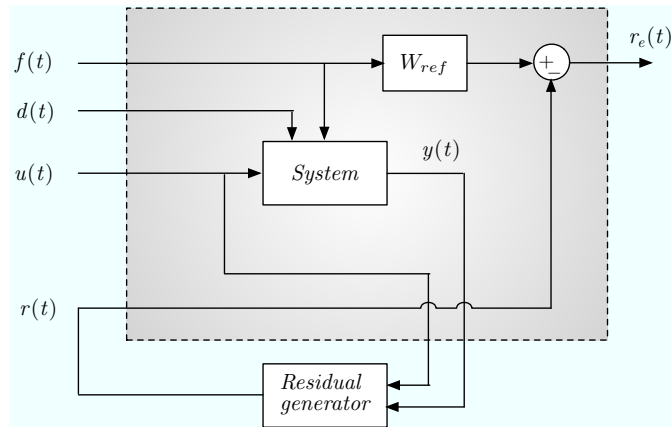

Figure 1: Scheme of robust residual generation

The problem of simultaneously minimizing the effect of the disturbances and maximizing the effect of the fault on the residual can be reduced to a single problem by introducing a transfer function  $W_{ref}$  corresponding to the desired transfer from the fault  $f(t)$  to the residual  $r(t)$ . Then robust residual generator (RRG) reduces to minimize the influence of exogenous signals ( $d(t)$ ,  $f(t)$ ) on the difference between the

desired and the obtained residual, denoted  $r_e(t)$ , defined by

$$r_e(s) = r(s) - W_{ref}(s)f(s) \quad (14)$$

which turns to be an  $\mathcal{L}_2$ -control problem (that is a generalization of the  $\mathcal{H}_\infty$ -control problem to the non-linear case).

In other words, if  $r_e(t)$  is minimized, then  $r(t)$  will reflect the presence of the fault  $f(t)$  as described by  $W_{ref}$ . Obviously,  $f(t)$  is not accessible and the filter  $W_{ref}$  cannot be implemented on the faulty system: the robust residual generation presented as a control scheme (as can be viewed on figure 1) is only used for the design of RRG. Once the RRG is computed, it is implemented as described by (6), where it is only fed with the measured signals  $u(t)$ ,  $y(t)$  and the known decision variable  $\xi(t)$ . As explained in [35] the FDI problem depends on the selected structure of the transfer matrix  $W_{ref}$ . Indeed, the fault estimation problem is obtained when  $n_r = n_f$  and  $W_{ref} = I_{n_f}$  (or at least an invertible matrix) since in that case the residual  $r(t)$  directly follows the fault  $f(t)$ ; the fault detection problem is considered when  $n_r = 1$  and  $W_{ref} \in \mathbb{R}^{1 \times n_f}$  (with no null entry) since in that case the single residual is sensitive to all the possible faults. In addition,  $W_{ref}$  can be chosen as a dynamic system (linear in order to not artificially complicate the FDI procedure). Consider the transfer matrix  $W_{ref} = D_{ref} + C(sI - A_{ref})^{-1}B_{ref}$ , with  $D_{ref} \in \mathbb{R}^{n_r \times n_f}$ , defined by:

$$W_{ref} = \left( \begin{array}{c|c} A_{ref} & B_{ref} \\ \hline C_{ref} & D_{ref} \end{array} \right) \quad (15)$$

$W_{ref} \in \mathcal{S}$  where  $\mathcal{S}$  is the set of stable filters having the following property:

$$\|W_{ref}\|_- = \inf_{w \in \mathbb{R}} (\underline{\sigma}(W_{ref}(jw))) \geq 1 \quad (16)$$

(see [24] and [25] for more details). The interest of this kind of filters is that there is no attenuation of the faults but only an amplification on all frequency ranges (constraint (16)) which may improve the performances of the fault detection method. The detection, isolation and estimation of the faults can be obtained by an appropriate choice of the matrices  $A_{ref}$ ,  $B_{ref}$ ,  $C_{ref}$  and  $D_{ref}$ . The FDI problem is then formulated as the following multi-objective optimization problem. Let us denote  $x_{ref}(t)$  the state of the system described by the transfer matrix  $W_{ref}$  (15) fed with  $f(t)$  (see figure 1).

In order to rewrite the whole model in a state space representation, let us define the augmented state vector  $\tilde{e}(t)^T = [e(t)^T \ x_{ref}(t)^T]$ . Using (7) and (15), the virtual residual vector  $r_e(t)$  (14) is generated by the system

$$\begin{cases} \dot{\tilde{e}}(t) = \tilde{A}_{\xi\xi} \tilde{e}(t) + \tilde{E}_{\xi\xi} \tilde{d}(t) \\ r_e(t) = \tilde{C}_{\xi} \tilde{e}(t) + \tilde{G}_{\xi} \tilde{d}(t) \end{cases} \quad (17)$$



where the following notations are used

$$\tilde{A}_{\xi\xi} = \sum_{i=1}^r \sum_{j=1}^r \mu_i(\xi(t)) \mu_j(\xi(t)) \begin{pmatrix} A_i - L_i C_j & 0 \\ 0 & A_{ref} \end{pmatrix} \quad (18)$$

$$\tilde{E}_{\xi\xi} = \sum_{i=1}^r \sum_{j=1}^r \mu_i(\xi(t)) \mu_j(\xi(t)) \begin{pmatrix} E_i - L_i G_j & F_i - L_i R_j \\ 0 & B_{ref} \end{pmatrix} \quad (19)$$

$$\tilde{C}_{\xi} = \sum_{i=1}^r \mu_i(\xi(t)) \begin{pmatrix} M C_i & -C_{ref} \end{pmatrix} \quad (20)$$

$$\tilde{G}_{\xi} = \sum_{i=1}^r \mu_i(\xi(t)) \begin{pmatrix} M G_i & M R_i - D_{ref} \end{pmatrix} \quad (21)$$

$$\tilde{e}(t) = \begin{pmatrix} e(t) \\ x_{ref}(t) \end{pmatrix} \quad (22)$$

$$\tilde{d}(t) = \begin{pmatrix} d(t) \\ f(t) \end{pmatrix} \quad (23)$$

The objective is now to obtain the gains  $L_i$  and  $M$  of the observer minimizing the effects of the perturbations  $d(t)$  and the faults  $f(t)$  on the virtual residual  $r_e(t)$ . That problem leads to solve a standard  $\mathcal{L}_2$ -control problem where  $d(t)$  and  $f(t)$  are the exogenous signals and  $r_e(t)$  is the controlled output. The choice of the filter  $W_{ref}$  is important because it allows the shaping of the residual response in order to achieve the fault isolation and estimation.

Theorem 1 states the robust fault detection, isolation and estimation as a minimization problem under LMI constraints allowing to design the residual generator (6) and to give a bound of the transfer from  $(d(t)^T \ f(t)^T)^T$  to  $r_e(t)$ .

**Theorem 1.** *The robust residual generator (6) exists if there exists symmetric and positive definite matrices  $P_1$  and  $P_2$ , matrices  $K_i$  and  $M$  and a positive scalar  $\gamma$  solving the following optimization problem:*

$$\min_{P_1, P_2, K_i, M} \gamma \quad (24)$$

under the following LMI constraints

$$\begin{cases} X_{ii} < 0, & i = 1, \dots, r \\ \frac{2}{r-1} X_{ii} + X_{ij} + X_{ji} < 0, & i, j = 1, \dots, r, i \neq j \end{cases} \quad (25)$$

where, for  $(i, j) \in \{1, \dots, r\}$ ,  $X_{ij}$  and  $\Phi_{ij}$  are defined by

$$X_{ij} = \begin{pmatrix} \Phi_{ij} & 0 & P_1 E_i - K_i G_j & P_1 F_i - K_i R_j & C_i^T M^T \\ * & A_{ref}^T P_2 + P_2 A_{ref} & 0 & P_2 B_{ref} & -C_{ref}^T \\ * & * & -\gamma I & 0 & G_i^T M^T \\ * & * & * & -\gamma I & R_i^T M^T - D_{ref}^T \\ * & * & * & * & -\gamma I \end{pmatrix} \quad (26)$$

$$\Phi_{ij} = A_i^T P_1 + P_1 A_i - C_j^T K_i^T - K_i C_j \quad (27)$$

The residual generator gains  $L_i$  are obtained by:

$$L_i = P_1^{-1} K_i \quad (28)$$

and  $M$  is obtained directly. The attenuation level of exogenous signals on residuals is given by  $\gamma$ .

*Proof.* Using the bounded real lemma (BRL) [4], the stability of the system (17) is ensured when  $\tilde{d}(t) = 0$  and the  $\mathcal{L}_2$ -gain of the transfer from  $\tilde{d}(t)$  to  $r_e(t)$  is bounded by  $\gamma$  if the following condition is satisfied

$$\begin{pmatrix} \tilde{A}_{\xi\xi}^T P + P \tilde{A}_{\xi\xi} & P \tilde{E}_{\xi\xi} & \tilde{C}_{\xi}^T \\ * & -\gamma I & \tilde{G}_{\xi}^T \\ * & * & -\gamma I \end{pmatrix} < 0 \quad (29)$$

In order to obtain a more explicit inequality in terms of the gain matrices  $L_i$  and  $M$ , the matrix  $P$  is chosen in block diagonal form as follows:

$$P = \begin{pmatrix} P_1 & 0 \\ 0 & P_2 \end{pmatrix} \quad (30)$$

The definitions (18-21) and the chosen matrix  $P$  (30) allow to derive from (29) the following inequality

$$X_{\xi\xi} = \sum_{i=1}^r \sum_{j=1}^r \mu_i(\xi(t)) \mu_j(\xi(t)) X_{ij} < 0 \quad (31)$$

where:

$$X_{ij} = \begin{pmatrix} \Phi_{ij} & 0 & P_1 E_i - P_1 L_i G_j & P_1 F_i - P_1 L_i R_j & C_i^T M^T \\ * & A_{ref}^T P_2 + P_2 A_{ref} & 0 & P_2 B_{ref} & -C_{ref}^T \\ * & * & -\gamma I & 0 & G_i^T M^T \\ * & * & * & -\gamma I & R_i^T M^T - D_{ref}^T \\ * & * & * & * & -\gamma I \end{pmatrix} \quad (32)$$

and the nonlinear functions  $\mu_i(\xi(t))$  satisfy the convex sum property (3) and  $X_{\xi\xi}$  defined by (31). As

established in [44], the inequality (31) holds if

$$\begin{cases} X_{ii} < 0, & i = 1, \dots, r \\ \frac{2}{r-1}X_{ii} + X_{ij} + X_{ji} < 0, & i, j = 1, \dots, r, i \neq j \end{cases} \quad (33)$$

Applying this result and using the change of variable  $K_i = P_1 L_i$ , the inequality (31) holds if inequalities (25) with the definitions (26)-(27) are satisfied. Notice that (25) are expressed in LMI formulation regarding to  $P_1, P_2, K_i$  and  $M$ . Finally, an optimal residual generator is obtained by minimizing  $\gamma$  in order to minimize the effect of  $\tilde{d}(t)$  on the virtual residual  $r_e(t)$ .  $\square$

## 4 Robust fault diagnosis

Due to the presence of exogenous disturbances, the residual signals are different from zero even in the fault-free case. In the framework of fault detection, a threshold,  $J_{th}$ , is generated in a fault-free situation. A fault detection alarm is generated by comparison between each component  $r_i(t)$  of the residual signal  $r(t)$  and the threshold:

$$\begin{cases} |r_i(t)| < J_{th} \Rightarrow \text{no fault} \\ |r_i(t)| > J_{th} \Rightarrow \text{fault} \end{cases} \quad (34)$$

In order to improve the fault detection and isolation, a residual generator can be constructed for each fault. Each residual generator is designed to minimize the transfer from  $(d(t)^T \ f(t)^T)^T$  to  $r_{e,i}(t) = r_i(t) - W_{ref,i} f_i(t)$ ,  $i = 1, \dots, n_f$ ,  $f_i(t)$  being the  $i^{th}$  component of the vector  $f(t)$  and  $W_{ref,i}$  a specific filter corresponding to the desired transfer from the fault  $f_i(t)$  to the residual  $r_i(t)$ .

As previously mentioned, it is often considered that the fault vector  $f(t)$  may have two origins, the first one denoted  $f_a(t)$  represents the fault vector affecting only the actuators, which appears in the state equation. The second component denoted  $f_s(t)$  is the fault vector affecting only the sensors. The output of the system is still given by the second equation of (4) but, in that case, the fault incidence matrices have the following particular structures

$$F_i = \begin{pmatrix} F_i^1 & 0 \end{pmatrix}, \quad R_i = \begin{pmatrix} 0 & R_i^1 \end{pmatrix} \quad (35)$$

according to the decomposition of  $f(t) = (f_a^T(t) \ f_s^T(t))^T$ . As explained in [35] and [24], if the matrices  $R_i$  defined by (35) (for  $i \in \{1, \dots, r\}$ ) are not full column rank, this will have an adverse effect on the minimal values of  $\gamma$ . It is well known in the  $H_\infty$ -control framework that the obtainable  $\gamma$  is at least equal to the maximal singular value of the direct transfer from the exogenous signal to the controlled output, namely  $\tilde{G}_\xi$  defined in (21). From (21), it can be seen that if  $D_{ref}$  is not null,  $R_i$  is useful to minimize the maximal singular value of  $\tilde{G}_\xi$ . As a consequence, column rank deficiency of the  $R_i$  matrices will result in limited performances of the residual generator, quantified by the minimum obtainable value of  $\gamma$ .

When the actuator fault  $f_a(t)$  does not affect the output equation of the system, we have  $R_i = \begin{pmatrix} 0 & R_i^1 \end{pmatrix}$

and clearly these matrices are not full column rank. In a first approach, in order to avoid this problem, a perturbation-like term  $R_i^0 f_a(t)$  is added on the output equation as follows:

$$y(t) = \sum_{i=1}^r \mu_i(\xi) \left( C_i x + D_i u + G_i d + \begin{pmatrix} R_i^0 & R_i^1 \end{pmatrix} \begin{pmatrix} f_a(t) \\ f_s(t) \end{pmatrix} \right) \quad (36)$$

where  $R_i^0$  are the distribution matrices of the actuator fault  $f_a(t)$  in the output equation and are chosen as small as possible. Notice that in the context of fault isolation, the introduction of the term  $R_i^0 f_a(t)$  may generate false alarms. To improve the isolation results, we propose to add and subtract the perturbation-like term. As a consequence, the matrices  $\begin{pmatrix} R_i^0 & R_i^1 \end{pmatrix}$  are guaranteed to be full column rank (if  $\dim(y) \geq \dim(f)$  which is a usual condition). The subtracted term is considered as a perturbation which influence is to be minimized. For that purpose, (36) is rewritten as

$$y(t) = \sum_{i=1}^r \mu_i(\xi) \left( C_i x + D_i u + \bar{G}_i \bar{d} + \bar{R}_i \begin{pmatrix} f_a(t) \\ f_s(t) \end{pmatrix} \right) \quad (37)$$

where

$$\bar{G}_i = \begin{pmatrix} G_i & bR_i^0 \end{pmatrix}, \quad \bar{R}_i = \begin{pmatrix} R_i^0 & R_i^1 \end{pmatrix}, \quad \bar{d}(t) = \begin{pmatrix} d(t) \\ -\frac{f_a(t)}{b} \end{pmatrix} \quad (38)$$

where  $b$  is a positive real parameter. Using this second approach, the residual generator is constructed as explain in section 3 and the threshold  $J_{th}$  is calculated by using the bound of the new perturbation vector  $\bar{d}(t)$ ; thus the fault isolation is improved.

## 5 Relaxed conditions for residual generator design using Polya's theorem

The proposed result may be conservative in the sense that it is derived from the use of a common Lyapunov matrix  $P$  that satisfies the  $r^2$  LMIs (25). Then, solving the optimization problem given in the previous theorem under the LMI constraints may fail to provide a solution. Recently, in [34, 29], a new interesting method to reduce the conservativeness of the matrix summations inequality has been proposed to study the stability of a matrix polytope with the use of Polya's theorem. The obtained conditions are sufficient and asymptotically necessary. The Polya's theorem is used, in this section, in order to derive less conservative LMI conditions.

Due to the convex sum property (3), it is obvious that for any positive integer  $p$ , the inequality (31) is equivalent to

$$\left( \sum_{k=1}^r \mu_k(\xi(t)) \right)^p \sum_{i=1}^r \sum_{j=1}^r \mu_i(\xi(t)) \mu_j(\xi(t)) X_{ij} < 0 \quad (39)$$

In order to write the multi-dimensional summations (39) in a compact form, let us consider the notations used in [34]:

$$\mathbb{I}_p = \{ \mathbf{i} = (i_1, i_2, \dots, i_p) \in \mathbb{N}^p \mid 1 \leq i_j \leq r \ \forall j = 1, 2, \dots, p \} \quad (40)$$

$$\sum_{\mathbf{i} \in \mathbb{I}_p} \mu_{\mathbf{i}} = \sum_{i_1}^r \sum_{i_2}^r \dots \sum_{i_p}^r \mu_{i_1} \mu_{i_2} \dots \mu_{i_p} \quad (41)$$

where  $\mathbf{i}$  represents a multi-dimensional multi-index, and:

$$\mu_{\mathbf{i}} = \prod_{\ell=1}^p \mu_{i_\ell} = \mu_{i_1} \mu_{i_2} \dots \mu_{i_p}, \quad \mathbf{i} \in \mathbb{I}_p \quad (42)$$

is a multi-dimensional fuzzy summations. Let us define  $\mathcal{P}(\mathbf{i}) \subset \mathbb{I}_p$  the set of permutations of the multi-index  $\mathbf{i}$ . For example, if:

$$\mathbf{i} = (1, 1, 2, 2) \quad (43)$$

then, the permutations set  $\mathcal{P}(\mathbf{i})$  is given by:

$$\mathcal{P}(\mathbf{i}) = \{(1, 1, 2, 2), (1, 2, 1, 2), (2, 1, 1, 2), (2, 1, 2, 1), (2, 2, 1, 1)\} \quad (44)$$

If:

$$\mathbf{j} \in \mathcal{P}(\mathbf{i}) \Rightarrow \mu_{\mathbf{j}} = \mu_{\mathbf{i}} \quad (45)$$

these permutations allows to group elements which share the same  $\mathbf{i}$ , for instance:

$$\mu_{(1,1,3,4)} = \mu_1^2 \mu_3 \mu_4 = \mu_{(1,3,1,4)} = \mu_{(3,1,1,4)} = \mu_{(3,1,4,1)} = \dots \quad (46)$$

Using the first result given in [34] in order to solve the problem of state estimation and residual generator addressed in section 3, less conservative sufficient conditions for the negativity of  $X_{\xi\xi}$ , defined by

$$X_{\xi\xi} = \sum_{i=1}^r \sum_{j=1}^r \mu_i(\xi(t)) \mu_j(\xi(t)) X_{ij} \quad (47)$$

are derived from the lemma 1 [34].

**Lemma 1.** *For any functions  $\mu_i$  satisfying (3) and any integer  $p \in \mathbb{N}$ , the matrix  $X_{\xi\xi}$  (47) is negative definite if*

$$\sum_{j \in \mathcal{P}(i)} X_{j_1 j_2} < 0, \quad \forall \mathbf{i} \in \mathbb{I}_p \quad (48)$$

As a particular case, setting  $p = 0$ , the problem reduces to theorem 1. It can be shown that the solution of this problem for a given value  $p_0$  of  $p$  is always solution of the problem with  $p > p_0$ , implying conservatism reduction.

## 5.1 Example

Let us consider a simple example where  $r = 2$ , then the system (7) is stable if  $X_{\xi\xi} < 0$  which is equivalent to (39). Setting  $p = 1$ , a triple summation is obtained, and the inequality  $X_{\xi\xi} < 0$  is equivalent to:

$$\sum_{i_1}^r \sum_{i_2}^r \sum_{i_3}^r \mu_{i_1} \mu_{i_2} \mu_{i_3} X_{i_1 i_2} < 0 \Leftrightarrow \sum_{\mathbf{i} \in \mathcal{P}(\mathbf{i})} \mu_{\mathbf{i}} X_{i_1 i_2} < 0 \quad (49)$$

where  $\mathbf{i} = (i_1, i_2, i_3)$  and  $i_1, i_2, i_3 = 1, \dots, 2$ .

- For  $\mathbf{i} = (1, 1, 1)$ , it follows:  $X_{11} < 0$
- For  $\mathbf{i} = (1, 1, 2)$ , three permutations are possible:  $X_{11} + X_{12} + X_{21} < 0$
- For  $\mathbf{i} = (1, 2, 2)$ , three permutations are possible:  $X_{22} + X_{21} + X_{12} < 0$
- For  $\mathbf{i} = (2, 2, 2)$ , it follows:  $X_{22} < 0$

In order to reduce the conservatism of the result in theorem 1, the Polya's theorem is applied directly on the inequality (31), with the changes of variables  $K_i = P_1 L_i$ , for a suitable value of  $p$ . Note that the obtained conditions are only sufficient for guaranteeing the negativity of (31) and as explained in [34], if  $p \rightarrow \infty$  asymptotic necessary and sufficient conditions are obtained, but the number of LMI constraints can drastically increase. Applying the Polya's theorem approach as used in [34] to the residual generator conditions detailed in theorem 1, the following result can be stated.

**Theorem 2.** *The robust residual generator (6) exists if there exists symmetric and positive definite matrices  $P_1$  and  $P_2$ , matrices  $K_i$  and  $M$  and a positive scalar  $\gamma$  solution to the following optimization problem:*

$$\min_{P_1, P_2, K_i, M} \gamma \quad (50)$$

under the constraints:

$$\sum_{j \in \mathcal{P}(\mathbf{i})} X_{j_1 j_2} < 0, \quad \forall \mathbf{i} \in \mathbb{I}_p \quad (51)$$

where  $X_{j_1 j_2}$  is defined by (26) and  $j_1, j_2$  belong to  $\mathcal{P}(\mathbf{i}) \subset \mathbb{I}_p$  where  $\mathcal{P}(\mathbf{i})$  is the set of all permutations of the multi-index  $\mathbf{i}$ . The gains of the observer are given by  $L_i = P_1^{-1} K_i$  and the attenuation level is  $\gamma$ .

Using the Polya's theorem and setting  $p = 3$ , the following theorem 3 is obtained.

**Theorem 3.** *The robust residual generator (6) exists if there exists symmetric and positive definite matrices  $P_1$  and  $P_2$ , matrices  $K_i$  and  $M$  and a positive scalar  $\gamma$  solution to the following optimization problem:*

$$\min_{P_1, P_2, K_i, M} \gamma, \quad \text{s.t} \quad (52)$$

$$X_{ii} < 0$$

$$i = 1, \dots, r$$

$$3X_{ii} + X_{ij} + X_{ji} < 0$$

$$i, j = 1, \dots, r, \quad i \neq j$$

$$3X_{ii} + X_{jj} + 3X_{ij} + 3X_{ji} < 0$$

$$i, j = 1, \dots, r, \quad i \neq j$$

$$6X_{ii} + 3X_{ij} + 3X_{ik} + 3X_{ji} + 3X_{ki} + X_{jk} + X_{kj} < 0$$

$$i, j, k = 1, \dots, r, \quad i < j < k$$

$$3X_{ii} + 3X_{jj} + 6X_{ij} + 6X_{ji} + 3X_{ik} + 3X_{ki} + 3X_{jk} + 3X_{kj} < 0$$

$$i, j, k = 1, \dots, r, \quad i < j < k$$

$$3X_{ii} + 3X_{jj} + 6X_{ij} + 6X_{ji} + 3X_{ik} + 3X_{ki} + 3X_{jk} + 3X_{kj} < 0$$

$$i, j, k = 1, \dots, r, \quad i < j < k$$

$$6X_{ii} + 6X_{ij} + 6X_{ji} + 6X_{ik} + 6X_{ki} + 6X_{il} + 6X_{li} + 3X_{jk} + 3X_{kj} + 3X_{jl} + 3X_{lj} + 3X_{kl} + 3X_{lk} < 0$$

$$i, j, k = 1, \dots, r, \quad i < j < k < l$$

$$6(X_{ij} + X_{ji} + X_{ik} + X_{ki} + X_{il} + X_{li} + X_{im} + X_{mi} + X_{jk} \\ + X_{kj} + X_{jl} + X_{lj} + X_{jm} + X_{mj} + X_{kl} + X_{lk} + X_{km} + X_{mk}) < 0$$

$$i, j, k, l, m = 1, \dots, r, \quad i < j < k < l < m$$

where  $X_{ij}$  is defined in (26). The gains of the observer are given by  $L_i = P_1^{-1}K_i$  and the attenuation level is  $\gamma$ .

*Proof.* According to theorem 1, the solution of the RRG problem is obtained by minimizing  $\gamma$  under the constraint  $\sum_{i=1}^r \sum_{j=i}^r \mu_i(\xi(t))\mu_j(\xi(t))X_{ij} < 0$ , which due to the convex property of the weighting functions is equivalent to

$$\left( \sum_{k=1}^r \mu_k(\xi(t)) \right)^p \sum_{i=1}^r \sum_{j=i}^r \mu_i(\xi(t))\mu_j(\xi(t))X_{ij} < 0 \quad (53)$$

In the following, for the sake of clarity, the term  $\xi(t)$  is omitted. Setting  $p = 3$  and gathering the terms

sharing the same combinations of weighting functions, it follows

$$\begin{aligned}
& \left( \sum_{i=1}^r \mu_i \right)^3 \sum_{i=1}^r \sum_{j=1}^r \mu_i \mu_j X_{ij} = \sum_{i=1}^r \mu_i^5 X_{ii} + \sum_{\substack{i,j=1 \\ i \neq j}}^r \mu_i^4 \mu_j (3X_{ii} + X_{ij} + X_{ji}) \\
& + \sum_{\substack{i,j=1 \\ i \neq j}}^r \mu_i^3 \mu_j^2 \tilde{X}_{ij} + \sum_{i=1}^r \sum_{\substack{j=1 \\ i < j}}^r \sum_{\substack{k=1 \\ j < k}}^r \mu_i^3 \mu_j \mu_k \tilde{X}_{ijk} + \sum_{i=1}^r \sum_{\substack{j=1 \\ i < j}}^r \sum_{\substack{k=1 \\ j < k}}^r \mu_i^2 \mu_j^2 \mu_k \tilde{X}_{ijk}^* \\
& + \sum_{i=1}^r \sum_{\substack{j=1 \\ i < j}}^r \sum_{\substack{k=1 \\ j < k}}^r \sum_{\substack{l=1 \\ k < l}}^r \mu_i^2 \mu_j \mu_k \mu_l \tilde{X}_{ijkl} + \sum_{i=1}^r \sum_{\substack{j=1 \\ i < j}}^r \sum_{\substack{k=1 \\ j < k}}^r \sum_{\substack{l=1 \\ k < l}}^r \sum_{\substack{m=1 \\ l < m}}^r \mu_i \mu_j \mu_k \mu_l \mu_m \tilde{X}_{ijklm} < 0 \tag{54}
\end{aligned}$$

with

$$\begin{aligned}
\tilde{X}_{ij} &= 3X_{ii} + X_{jj} + 3X_{ij} + 3X_{ji} \\
\tilde{X}_{ijk} &= 6X_{ii} + 3(X_{ij} + X_{ji} + X_{ik} + X_{ki}) + X_{jk} + X_{kj} \\
\tilde{X}_{ijk}^* &= 3X_{ii} + 3X_{jj} + 6X_{ij} + 6X_{ji} + 3X_{ik} + 3X_{ki} + 3X_{jk} + 3X_{kj} \\
\tilde{X}_{ijkl} &= 6(X_{ii} + X_{ij} + X_{ji} + X_{ik} + X_{ki} + X_{il} + X_{li}) + 3(X_{jk} + X_{kj} + X_{jl} + X_{lj} + X_{kl} + X_{lk}) \\
\tilde{X}_{ijklm} &= 6(X_{ij} + X_{ji} + X_{ik} + X_{ki} + X_{il} + X_{li} + X_{im} + X_{mi} + X_{jk} \\
& \quad + X_{kj} + X_{jl} + X_{lj} + X_{jm} + X_{mj} + X_{kl} + X_{lk} + X_{km} + X_{mk})
\end{aligned}$$

what allows to find the constraints listed in theorem 3, which ends the proof.  $\square$

## 6 Illustrative example 1

The proposed algorithm of robust diagnosis is illustrated by an academic example. Let us consider the nonlinear system (4) defined by

$$A_1 = \begin{pmatrix} -1 & 4 & 1 \\ 1 & -3 & 0 \\ -2 & 1 & -10 \end{pmatrix}, \quad A_2 = \begin{pmatrix} -3 & 1 & -2 \\ 6 & -3 & 0 \\ 1 & 2 & -4 \end{pmatrix}, \quad B_1 = \begin{pmatrix} 1 \\ 5 \\ 0.5 \end{pmatrix}, \quad B_2 = \begin{pmatrix} 3 \\ 1 \\ -1 \end{pmatrix},$$

$$E_1 = \begin{pmatrix} 0.5 \\ 1 \\ 1 \end{pmatrix}, \quad E_2 = \begin{pmatrix} 1 \\ 0.3 \\ 0.5 \end{pmatrix}, \quad F_1 = \begin{pmatrix} 0 & 2 \\ 0 & 1 \\ 0 & 1 \end{pmatrix}, \quad F_2 = \begin{pmatrix} 0 & 1 \\ 0 & 3 \\ 0 & 1 \end{pmatrix},$$

and

$$C_1 = \begin{pmatrix} 1 & 1 & 1 \\ 0 & 0 & 1 \end{pmatrix}, \quad C_2 = \begin{pmatrix} 1 & 1 & 0 \\ 1 & 0 & 1 \end{pmatrix}, \quad G_1 = G_2 = \begin{pmatrix} 0.5 \\ 1 \end{pmatrix}, \quad R_1 = R_2 = \begin{pmatrix} 1 & 0 \\ 3 & 0 \end{pmatrix}$$



The weighting functions  $\mu_i$  are defined as follows:

$$\begin{cases} \mu_1(u(t)) = \frac{1 - \tanh((u(t) - 1)/10)}{2} \\ \mu_2(u(t)) = 1 - \mu_1(u(t)) \end{cases} \quad (55)$$

Considering the structure of the matrices  $E_i$  and  $G_i$ , the disturbance input vector  $d(t)$  affects the outputs of the system and its dynamic. In the other hand, considering the structure of  $F_i$  and  $R_i$ , the first component of the vector  $f(t)$  is a sensor fault and the second component is an actuator fault defined by:

$$f_1(t) = f_s(t) = \begin{cases} 1, & \text{if } 10 \leq t \leq 16 \\ 0, & \text{else} \end{cases} \quad (56)$$

$$f_2(t) = f_a(t) = \begin{cases} 1, & \text{if } 4 \leq t \leq 8 \\ 0, & \text{else} \end{cases} \quad (57)$$

The initial conditions of the state of the system and those of the residual generators are the same:  $x(0) = \hat{x}(0) = [2 \ -2 \ -1]^T$ .

## 6.1 Fault detection and isolation

The problem of residual generation is stated as designing a set of filters that furnish residuals such that each residual is devoted to detect a particular fault or a particular set of faults. A bank of three residual generators is designed (see figure 2) in order to illustrate the effectiveness of the proposed approach in fault detection and fault isolation. Since a system with two measured outputs is considered, the fault isolation may be obtained with two generators where each one is dedicated to a specific fault, or with a single generator delivering a residual vector such that each of its entries corresponds to one of the two faults. The first and the second generators  $RG^1$  and  $RG^2$  are dedicated to the isolation of sensor fault and actuator fault respectively, while the third one  $RG^3$  is built to detect simultaneously both faults. A comparison between the performances of a global residual generator  $RG^3$  and the bank of residual generator  $RG^1$  and  $RG^2$  will be given. The three generators have dynamic characteristics fixed by the block  $A_{ref}^i$  of the transfer matrix  $W_{ref}^i$ . The problem of fault isolation is performed by residual structuring, i.e. choosing adequate values of the block  $W_{ref}$  to make the residual generator sensitive or insensitive to a specific fault.

- The first residual generator is designed with a stable filter  $W_{ref}$  (15) defined by

$$W_{ref}^1 = \left( \begin{array}{c|cc} -120 & 1 & 0 \\ \hline 1 & 1 & 0 \end{array} \right) \quad (58)$$

The aim of this choice is to generate a reference signal corresponding to the (low-pass filtered)

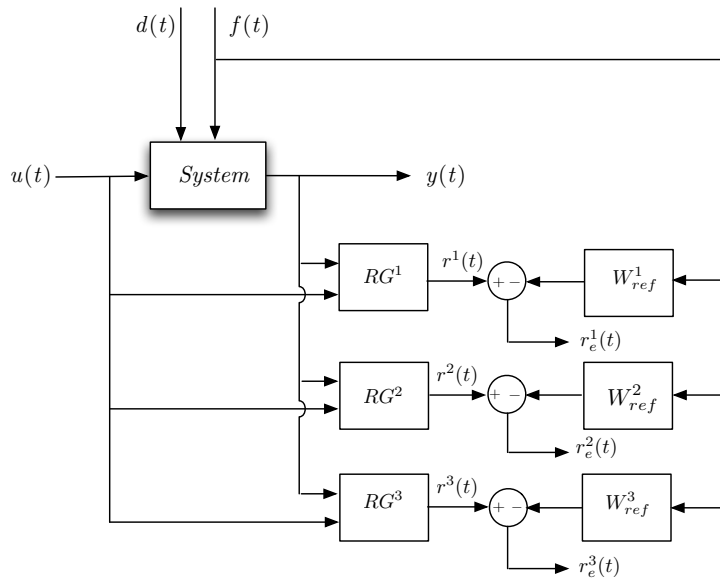

Figure 2: Scheme of robust residual generation

sensor fault. Indeed, with this filter  $W_{ref}^1$ , the residual generator 1 generates the residual  $r^1(t)$  which will be sensitive to the first fault (sensor fault) and insensitive to the second one (actuator fault). After solving the optimization problem of theorem 1 under LMI constraints (25), the obtained attenuation level is  $\gamma_1 = 0.5306$ . The threshold is  $J_{th} = 0.3$ . The simulation results are depicted in the figure 3. The residual  $r^1(t)$  clearly allows the detection of the sensor fault and is quite insensitive to the actuator fault (occurring between  $t = 4$  and  $t = 8$ ).

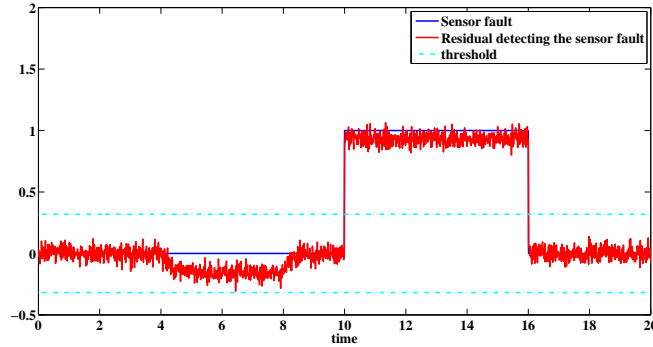

Figure 3: Residual generator 1 : Sensor fault detection

- The second residual generator is performed with

$$W_{ref}^2 = \left( \begin{array}{c|cc} -90 & 0 & 1 \\ \hline 1 & 0 & 1 \end{array} \right) \quad (59)$$

It is sensitive to the actuator fault and insensitive to the sensor fault. As explained in the previous section, the matrix  $R$  is not full column rank. By following the proposed strategy to solve this problem with  $R_i^0 = 0.8$  and  $b = 1$  a solution is obtained to the optimization problem given in the

theorem 1. It results in  $\gamma_2 = 0.7363$  and  $J_{th} = 0.2$ . The figure 4 presents the obtained signal. The residual  $r^2(t)$  clearly allows the detection of the actuator fault while being insensitive to the sensor fault (occurring between  $t = 10$  and  $t = 16$ ).

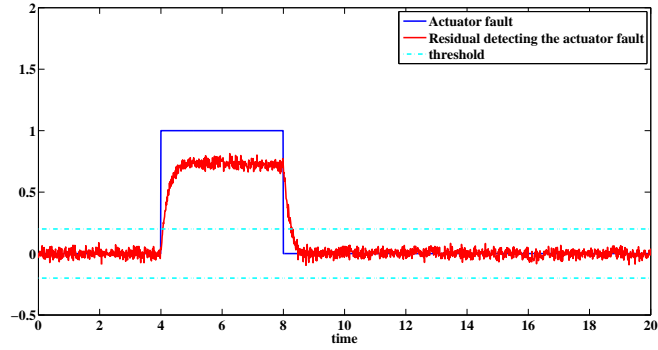

Figure 4: Residual generator 2 : Actuator fault detection

- Finally, the last residual generator is designed in order to simultaneously performs fault detection and fault isolation. For that purpose, the filter  $W_{ref}^3$  is chosen as:

$$W_{ref}^3 = \left( \begin{array}{cc|cc} -120 & 0 & 1 & 0 \\ 0 & -90 & 0 & 1 \\ \hline 1 & 0 & 1 & 0 \\ 0 & 1 & 0 & 1 \end{array} \right) \quad (60)$$

and  $R_i^0 = 0.5$ ,  $b = 1$ . After designing the residual generator according to theorem 1, the obtained attenuation level is  $\gamma_3 = 0.7637$ . Each residual signal can detect one fault as illustrated in the figure 5, but it can be noted that the residual signal detecting the sensor fault is also affected by the actuator fault. This problem can be solved by using the bank of residual generators. Thus, the obtained results are better than those obtained by the global residual generator, designed with  $W_{ref}^3$ , as shown in figure 6.

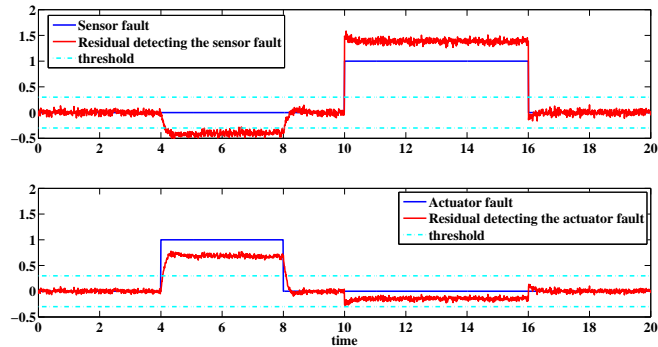

Figure 5: Residual generator 3 : Fault detection and isolation of actuator and sensor faults

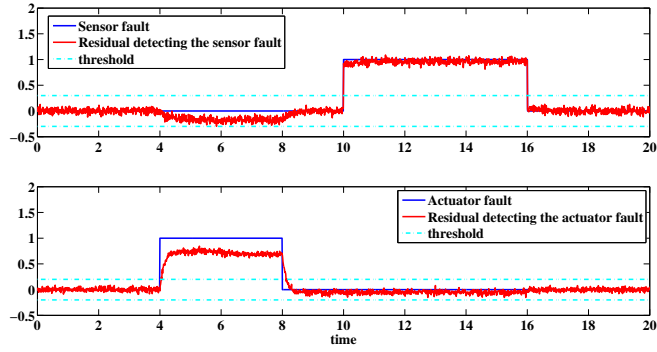

Figure 6: Residual generators 1 and 2 : Fault detection and isolation of actuator and sensor faults

It can be mentioned that the dedicated RRG allow to obtain lower  $\mathcal{L}_2$ -gains (i.e.  $\max(\gamma_1, \gamma_2) \leq \gamma_3$ ) by splitting the transfer matching constraints into two different problems.

- Now, assume that the faults  $f_s(t)$  and  $f_a(t)$  may appear simultaneously (for  $t \in [6\ 16]$  and  $t \in [4\ 10]$  respectively). With the same parameters  $W_{ref}^3$ ,  $R_i^0$  and  $b$  used previously, the simulation results are given in the figure 7. It can be seen that the third residual generator is able to detect and isolate simultaneous occurring faults.

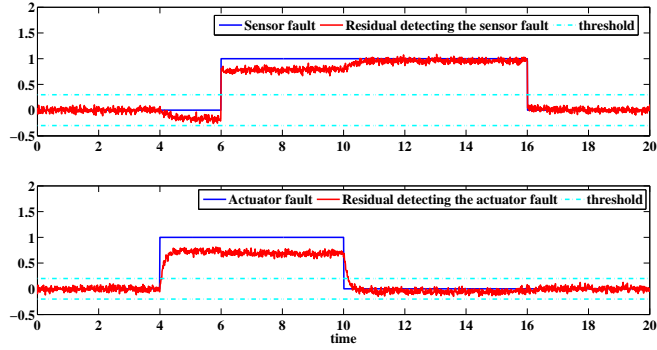

Figure 7: Residual generator 3 : Simultaneous actuator and sensor fault detection and isolation

In order to illustrate the enhancement offered by the relaxed conditions using Polya's theorem, in figure 8 the real faults  $f_a(t)$  and  $f_s(t)$  are represented by blue lines, while the residuals obtained by the approach in theorem 1 are depicted in black lines and the approach using Polya's theorem with  $p = 3$  gives residuals illustrated by red lines. It is clear that Polya's theorem provides more accurate results. It is due to the fact that the attenuation levels for each residual generator are less than those obtained using the method proposed in theorem 1.

## 6.2 Fault estimation

Another simulation is run in order to illustrate the fault estimation of both actuator and sensor faults with the bank of residual generators  $RG^1$  and  $RG^2$ . To do that, let us consider the parameter  $W_{ref} =$

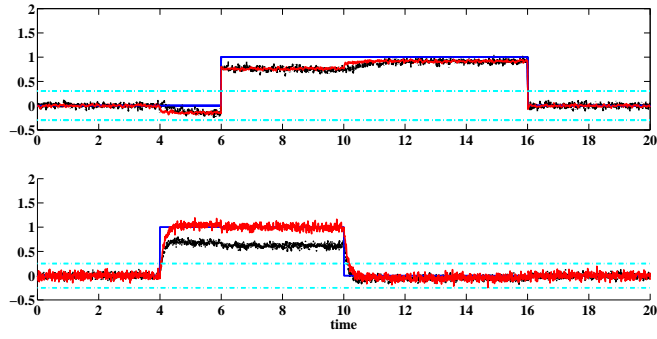

Figure 8: Residual generator comparison : approach of theorem 1 (black) and Polya's theorem approach (red)

$I_{2 \times 2}$  (an identity matrix). With the parameters  $R_i^0 = 0.5$  and  $b = 1$ , the solution of the optimization problem provides the attenuation level  $\gamma_1 = 0.5548$  for the first residual generator and  $\gamma_2 = 0.7133$  for the second residual generator. The simulation results are displayed in the figure 9. It can be noticed that the estimation of the faults are acceptable for both actuator and sensor.

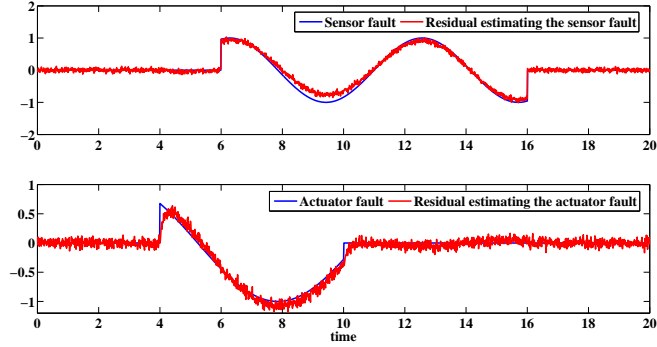

Figure 9: Actuator and sensor fault estimation

**Remark 1.** In order to enhance the residual generator robustness with regard to disturbances  $d(t)$ , it is possible to introduce a  $n_d$  order stable weighting transfer function  $W_{ref}^d$  as shown in the figure 10. This transfer function can take into account a possible knowledge on the frequency range distribution of the disturbance  $d(t)$ . The procedure is the same as that used for fault detection and isolation by including the reference filter  $W_{ref}$ . Then the goal is to design the residual generator in order to make each residual signal as sensitive as possible to a particular fault or set of faults and as insensitive as possible to the disturbances  $d(t)$  in the considered frequency range.

## 7 Illustrative example 2

In this second example, an application of the proposed fault diagnosis algorithm is illustrated by a flexible one link robot represented in the figure 11. The model of this system is described by the following equations borrowed from [33]

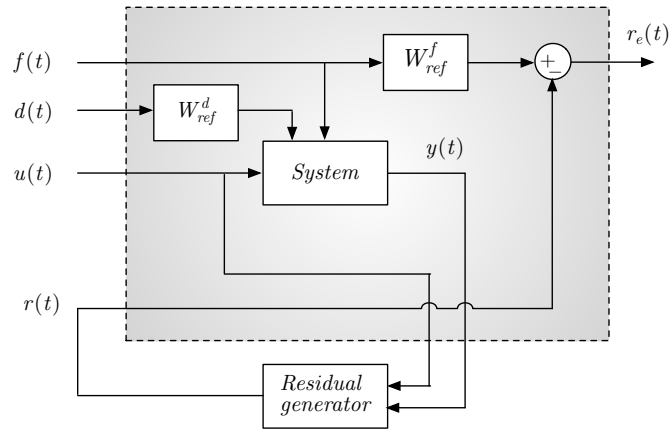

Figure 10: Scheme of robust residual generation

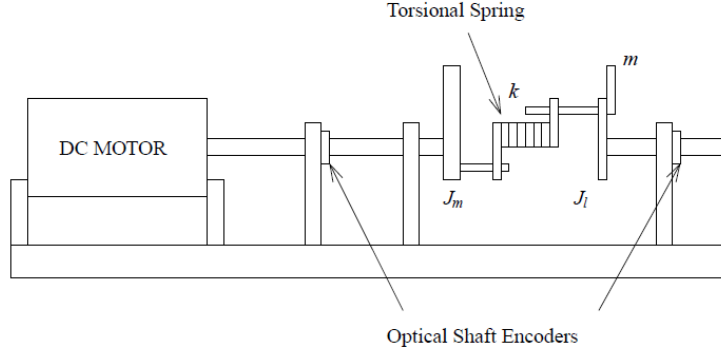

Figure 11: Flexible one link robot

$$\begin{cases} \dot{\theta}_m(t) = \omega_m(t) \\ \dot{\omega}_m(t) = \frac{k}{J_m}(\theta_l(t) - \theta_m(t)) - \frac{B}{J_m}\omega_m(t) + \frac{K_\tau}{J_m}u(t) \\ \dot{\theta}_l(t) = \omega_l(t) \\ \dot{\omega}_l(t) = -\frac{k}{J_l}(\theta_l(t) - \theta_m(t)) - \frac{mgh}{J_l}\sin(\theta_l(t)) \end{cases} \quad (61)$$

where  $\theta_m(t)$  and  $\omega_m(t)$  denote the angular position and velocity of the motor.  $\theta_l(t)$  and  $\omega_l(t)$  are the angular position and velocity of the link. The input signal is  $u(t) = \sin(t)$ . Assume that two faults  $f_a(t)$  and  $f_s(t)$  affect, respectively the state equation of the system and the output equation with respect to distribution matrices  $F$  and  $R$ . Furthermore, it is assumed that the system is subject to random perturbation  $d(t)$ , with maximal magnitude 1, affecting both the state and the output equations. Then, the state representation of the faulty perturbed system is

$$\begin{cases} \dot{x}(t) = Ax(t) + \phi(x(t)) + Bu(t) + Ff(t) + Ed(t) \\ y(t) = Cx(t) + Rf(t) + Gd(t) \end{cases}$$

where:

$$A = \begin{pmatrix} 0 & 1 & 0 & 0 \\ -48.6 & -1.25 & 48.6 & 0 \\ 0 & 0 & 0 & 1 \\ 19.5 & 0 & -19.5 & 0 \end{pmatrix}, B = \begin{pmatrix} 0 \\ 21.6 \\ 0 \\ 0 \end{pmatrix}, \phi(x) = \begin{pmatrix} 0 \\ 0 \\ 0 \\ -3.33 \sin(x_3) \end{pmatrix}$$

$$x(t) = \begin{pmatrix} \theta_m(t) \\ \omega_m(t) \\ \theta_l(t) \\ \omega_l(t) \end{pmatrix}, F = \begin{pmatrix} 0 & 0 \\ 1 & 0 \\ 1 & 0 \\ 0 & 0 \end{pmatrix}, E = \begin{pmatrix} 0 \\ 0.1 \\ 0 \\ 0 \end{pmatrix}, C = \begin{pmatrix} 0 & 0 & 1 & 0 \\ 1 & 0 & 0 & 0 \end{pmatrix}, R = \begin{pmatrix} 0 & 0 \\ 0 & 1 \end{pmatrix},$$

$$G = \begin{pmatrix} 0.1 \\ 0.1 \end{pmatrix}, f(t) = \begin{pmatrix} f_a(t) \\ f_s(t) \end{pmatrix}$$

$f(t)$  is vector containing a first component denoted  $f_a(t)$  which affects only the state equation and a second one denoted  $f_s(t)$  which is a fault affecting the sensor measuring  $x_1(t)$ . By using a sector nonlinearity transformation approach [42], a multiple model representation of the system described above is given by (4) with

$$A_1 = \begin{pmatrix} 0 & 1 & 0 & 0 \\ -48.6 & -1.25 & 48.6 & 0 \\ 0 & 0 & 0 & 1 \\ 19.5 & 0 & -22.83 & 0 \end{pmatrix}, A_2 = \begin{pmatrix} 0 & 1 & 0 & 0 \\ -48.6 & -1.25 & 48.6 & 0 \\ 0 & 0 & 0 & 1 \\ 19.5 & 0 & -18.77 & 0 \end{pmatrix}$$

$$B_1 = B_2 = B$$

$$\begin{cases} \mu_1(z(t)) = \frac{z(t)+0.2172}{1.2172} \\ \mu_2(z(t)) = \frac{1-z(t)}{1.2172} \end{cases}$$

where  $z(t) = \frac{\sin(x_3(t))}{x_3(t)}$ . The results presented in the theorem 1 are used to design a robust residual generator with the same filter as that used in the first example for fault estimation. In order to overcome the problem of rank deficiency of the matrices  $F$  and  $R$ , we choose the parameter  $R_i^0 = 0.254$ . After solving the optimization problem under LMI constraints, the obtained gains of the residual generator are

$$L_1 = \begin{pmatrix} -0.0363 & 0.0869 \\ 4.0080 & -0.0633 \\ 3.6853 & -0.0179 \\ -0.2219 & -0.0055 \end{pmatrix}, L_2 = \begin{pmatrix} -0.0363 & 0.0869 \\ 3.9603 & -0.0563 \\ 3.6469 & -0.0123 \\ 0.0725 & -0.0267 \end{pmatrix}, M = \begin{pmatrix} 3.4390 & -0.0002 \\ -0.9333 & 0.9983 \end{pmatrix}$$

The optimized parameter is  $\gamma = 0.6090$ . The figure 12 illustrates the faults  $f_a(t)$  and  $f_s(t)$  (blue solid lines) and the corresponding residuals (red dashed lines). In figure 13,  $f_a(t)$  and  $f_s(t)$  affecting, respectively, the state and the output equations are assumed to be time-varying faults (oscillatory signals). It appears that the residual generator is able to provide satisfactory fault estimates. Furthermore, as shown in figures 12 and 13, in the time interval  $[30 \ 35]$ , the system is subjected to simultaneous faults  $f_a(t)$  and  $f_s(t)$ . One can clearly observe that the first residual is only sensitive to the fault  $f_a(t)$  and the second one is only sensitive to  $f_s(t)$ . This is the result of maximizing of the effect of  $f_a(t)$  (resp.  $f_s(t)$ ) with respect to the first (resp. second) residual signal when minimizing the effect of  $f_s(t)$  (resp.  $f_a(t)$ ) on that residual signal.

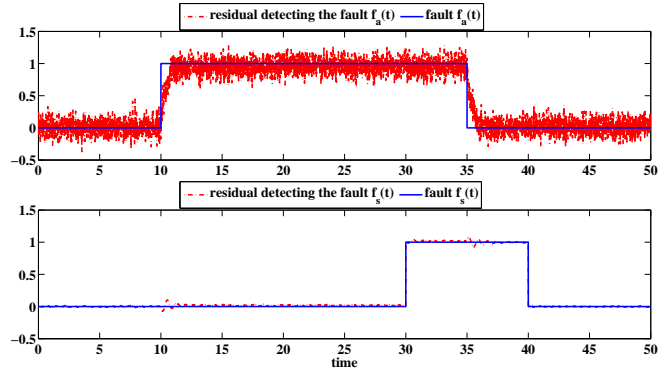

Figure 12: Fault estimation

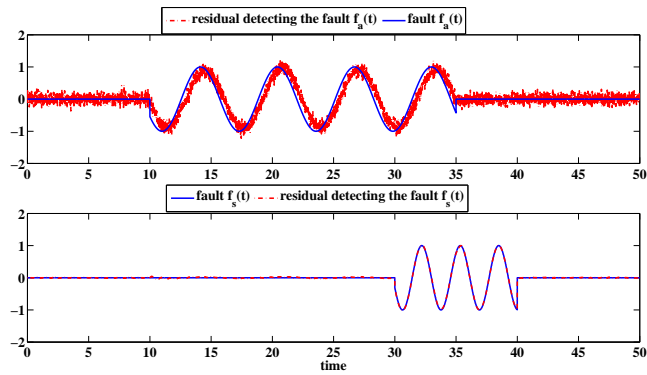

Figure 13: Time-varying fault estimation

## 8 Illustrative example 3

In order to illustrate the relaxation introduced with Polyá's theorem, consider the Takagi-Sugeno system (4) defined by:

$$A_1 = \begin{pmatrix} 1.59 & -7.29 \\ 0.01 & 0 \end{pmatrix}, \quad A_2 = \begin{pmatrix} -a & -4.33 \\ 0 & 0.05 \end{pmatrix}$$



$$B_1 = \begin{pmatrix} 1 \\ 0 \end{pmatrix}, B_2 = \begin{pmatrix} 0 \\ 1 \end{pmatrix}, E_1 = \begin{pmatrix} 1 \\ 3 \end{pmatrix}, E_2 = \begin{pmatrix} 2 \\ 1 \end{pmatrix}$$

$$F_1 = \begin{pmatrix} 1 \\ 1.5 \end{pmatrix}, F_2 = \begin{pmatrix} 2 \\ 3 \end{pmatrix}, C_1 = \begin{pmatrix} 6 & 0 \end{pmatrix}, C_2 = \begin{pmatrix} 6-b & -1 \end{pmatrix}$$

$$D_1 = D_2 = 0, G_1 = G_2 = 0.5, R_1 = 1, R_2 = 2$$

where  $a$  and  $b$  are scalar parameters for which different values will be further considered. In this simulation, the focus is made on the relaxation introduced by Poly's theorem, that is why only one RRG design is studied, namely the fault estimation case, with  $W_{ref} = 1$ . For that purpose, considering the inequality (31) and using the Poly's theorem, the following inequalities are obtained with respect to different values of  $p$  (i.e. the number of summations):

- For  $p = 1$

$$X_{ii} < 0, \quad i = 1, 2 \quad (62)$$

$$X_{ii} + X_{ij} + X_{ji} < 0, \quad i, j = 1, 2, \quad i \neq j \quad (63)$$

- For  $p = 2$

$$X_{ii} < 0, \quad i = 1, 2 \quad (64)$$

$$2X_{ii} + X_{ij} + X_{ji} < 0, \quad i, j = 1, 2, \quad i \neq j \quad (65)$$

$$X_{ii} + X_{jj} + 2X_{ij} + 2X_{ji} < 0, \quad i, j = 1, 2, \quad i < j \quad (66)$$

- For  $p = 3$

$$X_{ii} < 0, \quad i = 1, 2 \quad (67)$$

$$3X_{ii} + X_{ij} + X_{ji} < 0, \quad i, j = 1, 2, \quad i \neq j \quad (68)$$

$$3X_{ii} + X_{jj} + 3X_{ij} + 3X_{ji} < 0, \quad i, j = 1, 2, \quad i < j \quad (69)$$

Figure 14, shows the solution set, with the parameters  $a \in [8.5, 10]$  and  $b \in [5, 7]$ , obtained with a classical approach requiring the negativity of all the terms  $X_{ij}$  for all values of  $i$  and  $j$  and the solution set obtained with using Poly's theorem with  $p = 1$ . Note that, in this example  $r = 2$ , then, the LMIs obtained using Poly's theorem with  $p = 1$  are the same with those obtained with Tuan's lemma [44] presented in the first theorem. It can be concluded from this example that both Poly's theorem and Tuan's lemma provide a less conservative LMI conditions compared to the classic method.

A second simulation of the same example (with  $r = 2$ ) is performed in order to illustrate that the Tuan's relaxation scheme [44] is a special case of Poly's theorem and to compare the solutions obtained using Poly's theorem with  $p \in \{1, 2, 3\}$ . For T-S systems with large number of sub-models, Poly's theorem provides less conservative LMI conditions due to the fact that in Tuan's relaxation scheme, the

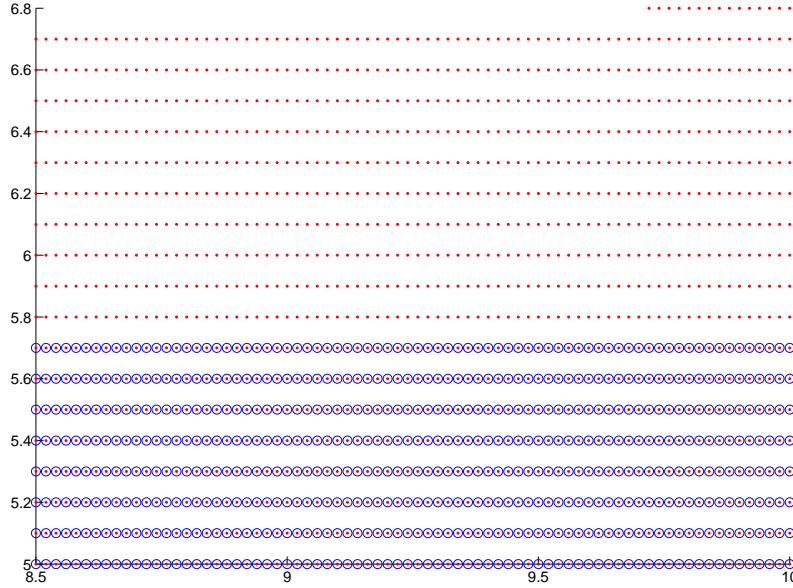

Figure 14: Solution sets for classical approach (o) and Polyá's theorem with  $p = 1$  (.)

first term in the second inequality of (25) is divided by  $(r - 1)$ , furthermore, with Polyá's theorem if there is no solution for a given  $p$ , it could be obtained by increasing the value of  $p$ . The results are depicted in the figure 15. Note that for some couples of the parameters  $a$  and  $b$ , the Tuan's approach don't provide a solution but with the approach based on Polyá's theorem, there exist solutions for the LMI constraints. Indeed, in this example, as can be seen in equations (62)-(69), for  $p = 1$ , the number of LMIs to solve is 4 and for  $p = 2, 3$  it becomes 5. The number of variables is the same for each  $p$  (11 scalar variables in this example). If we consider a TS system with 3 sub-models, the number of LMIs for  $p = 1$  is 9 and for  $p = 2$  is 12 but the number of scalar variables to solve remains the same for all  $p$  which consist, in the case of fault estimation problem, on the components of the matrices  $P_1$ ,  $L_i$ ,  $M$  and  $\gamma$ . As a conclusion, by increasing the parameter  $p$  the conservatism decreases. However, the number of LMIs to solve increases and the number of scalar variables in LMI problems remains the same for all  $p$ . With recent high-performance computers, it is possible to solve a great number of LMIs, this will not be affect the residual generator since the LMIs are solved offline.

## 9 Conclusion

This paper is dedicated to the design of residual generators for fault detection, isolation and estimation, in nonlinear systems described by Takagi-Sugeno models. The main idea is the extension of the  $\mathcal{L}_2$  formalism developed for nonlinear system control and estimation to the nonlinear robust fault diagnosis. The residual generator is designed to minimize the sensitivity to the perturbations and to maximize the sensitivity to the faults. This min/max optimization problem is turned into a simple matching problem by

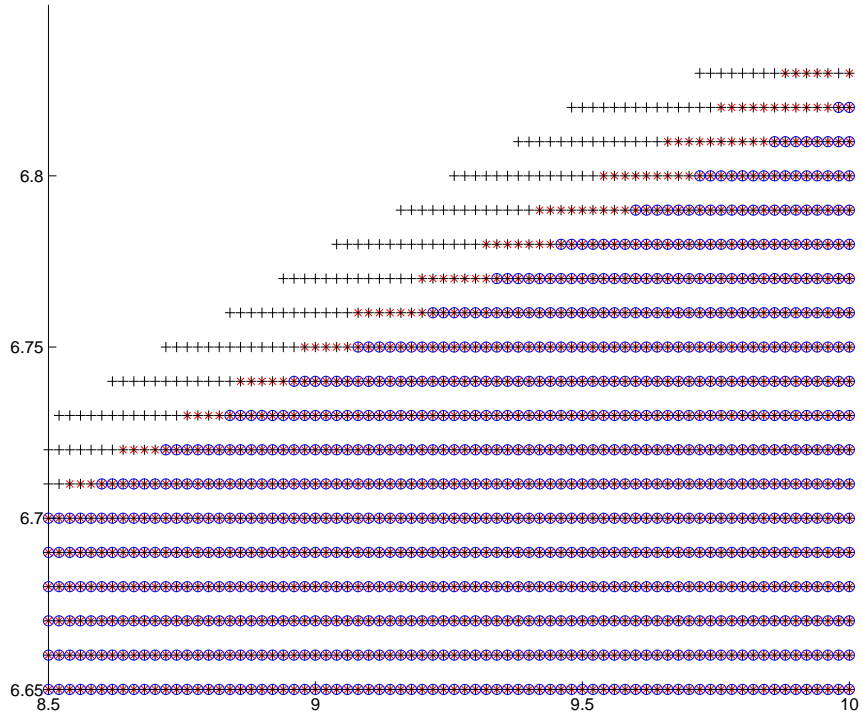

Figure 15: Solution sets using Polyá’s theorem with  $p = 1$  (o),  $p = 2$  (\*),  $p = 3$  (+)

introducing a reference transfer from the fault to the residual, which can be a constant matrix or a stable filter. Furthermore, the adequate choice of this reference parameter allows to shape the residual response to fault and achieves fault detection, fault isolation or fault estimation. By using the bounded real lemma (BRL) for this residual generator optimization problem the established constraints are expressed in terms of linear matrix inequalities. The diagnosis procedure is based on the definition of a threshold in the fault-free situation. An academic example is given in order to illustrate the proposed diagnosis strategies for actuator and sensor fault detection, isolation and estimation. The second part of this paper deals with the conservativeness reduction of the first proposed result. Using Polyá’s theorem, more relaxed LMI conditions are then given, allowing to decrease the attenuation level and obtain a more accurate diagnosis. It can be noticed from the simulation results that the proposed relaxation, significantly improves the obtained results.

For future works, two issues are envisaged, the first one will deal with the extension of this approach to nonlinear Takagi-Sugeno systems with unmeasurable premise variables. The second one will concern the LMI reduction in order to reduce the complexity of the optimization problem. An application of this residual generator for sensor fault tolerant control scheme has been already published in [15].

## References

- [1] A. Akhenak, M. Chadli, J. Ragot, and D. Maquin. Design of sliding mode unknown input observer for uncertain Takagi-Sugeno model. In *15th Mediterranean Conference on Control and Automation, MED'07*, Athens, Greece, 2007.
- [2] A. Akhenak, M. Chadli, J. Ragot, and D. Maquin. Fault detection and isolation using sliding mode observer for uncertain Takagi-Sugeno fuzzy model. In *16th Mediterranean Conference on Control and Automation, MED'08*, Ajaccio, France, 2008.
- [3] P. Bergsten, R. Palm, and D. Driankov. Observers for Takagi-Sugeno fuzzy systems. *IEEE Transactions on Systems, Man and Cybernetics - Part B: Cybernetics*, 32(1):114–121, 2002.
- [4] S. Boyd, L. El Ghaoui, E. Feron, and V. Balakrishnan. *Linear Matrix Inequalities in System and Control Theory*. SIAM ed., 1994.
- [5] M. Chadli, D. Maquin, and J. Ragot. Non quadratic stability analysis of Takagi-Sugeno systems. In *IEEE Conference on Decision and Control, CDC'2002*, Las Vegas, Nevada, USA, 2002.
- [6] W. Chen, and M. Saif. Design of a TS based fuzzy nonlinear unknown input observer with fault diagnosis applications. In *American Control Conference, ACC'07*, New York City, USA, 2007.
- [7] S. X. Ding. *Model-Based Fault Diagnosis Techniques Design Schemes, Algorithms And Tools*. Springer-Verlag, 2008.
- [8] G. Gasso. *Identification de systèmes dynamiques non linéaires : approche multi-modèle*. PhD thesis, Institut National Polytechnique de Lorraine (INPL), Nancy, France, 2000. (in french).
- [9] H. Gao, X. Liu, and J. Lam. Stability analysis and stabilization for discrete-time fuzzy systems with time-varying delay. *IEEE Transactions on Systems, Man and Cybernetics - Part B: Cybernetics*, 41(1): 273–286, 2011.
- [10] Z.F. Gao, B. Jiang, P. Shi, and Y.F. Xu. Fault accommodation for near space vehicle attitude dynamics via T-S fuzzy models. *International Journal of Innovative Computing, Information and Control*, 6(11): 4843–4856, 2010.
- [11] J.J. Gertler. *Fault Detection and Diagnosis in Engineering Systems*. Marcel Dekker, 1998.
- [12] T-M. Guerra, A. Kruszewski, L. Vermeiren, and H. Tirmant. Conditions of output stabilization for nonlinear models in the Takagi-Sugeno's form. *Fuzzy Sets and Systems*, 157(9):1248–1259, 2006.
- [13] D. Ichalal, B. Marx, J. Ragot, and D. Maquin. An approach for the state estimation of Takagi-Sugeno models and application to sensor fault diagnosis. In *48th IEEE Conference on Decision and Control, CDC'09*, Shanghai, P.R. China, 2009.

- [14] D. Ichalal, B. Marx, J. Ragot, and D. Maquin. Fault diagnosis in Takagi-Sugeno nonlinear systems. In *7th IFAC Symposium on Fault Detection, Supervision and Safety of Technical Processes, SAFEPROCESS'2009*, Barcelona, Spain, 2009.
- [15] D. Ichalal, B. Marx, D. Maquin and J. Ragot. Nonlinear observer based fault tolerant control for nonlinear systems. *8th IFAC Symposium on Fault Detection, Supervision and Safety for Technical Processes, SAFEPROCESS'2012*, Mexico, August 27-28, 2012.
- [16] D. Ichalal, B. Marx, J. Ragot, and D. Maquin. State estimation of nonlinear systems using multiple model approach. In *American Control Conference, ACC'2009*, St. Louis, Missouri, USA, 2009.
- [17] R. Isermann. *Fault-Diagnosis Systems: An Introduction From Fault Detection to Fault Tolerance*. Springer, 2007.
- [18] B. Jiang, Z.F. Gao, P. Shi, and Y.F. Xu. Adaptive fault-tolerant tracking control of near space vehicle using Takagi-Sugeno fuzzy models. *IEEE Transactions on Fuzzy Systems*, 18(5):1000-1007, 2010.
- [19] M. Johansson. *Piecewise Linear Control Systems*. PhD thesis, Department of Automatic Control, Lund Institute of Technology, Sweden, 1999.
- [20] J. Korbicz, J.M. Koscielny, Z. Kowalczyk, and W. Cholewa. *Fault Diagnosis: Models, Artificial Intelligence, Applications*. Springer, 2004.
- [21] A. Kruzewski, R. Wang, and T-M. Guerra. Non-quadratic stabilization conditions for a class of uncertain non linear discrete-time T-S fuzzy models: a new approach. *IEEE Transactions on Automatic Control*, 53(2):606–611, 2008.
- [22] L. Ligang, X. Su, P. Shi, and J. Qiu. Model approximation for discrete-time state-delay systems in the T-S fuzzy framework, *IEEE Transactions on Fuzzy Systems*, 19(2): 366-378, 2011.
- [23] B. Marx, D. Koenig, and J. Ragot. Design of observers for Takagi Sugeno descriptor systems with unknown inputs and application to fault diagnosis. *IET Control Theory and Application*, 1(5):1487–1495, 2007.
- [24] E. Mazars, I.M. Jaimoukha, and L. Zhenhai. Computation of a reference model for robust fault detection and isolation residual generation. *Journal of Control Science and Engineering*, article ID 790893, 2008. doi:10.1155/2008/790893.
- [25] E. Mazars, Z. Li, and I.M. Jaimoukha. A QMI approach to the robust fault detection and isolation problem. In *6th IFAC Symposium on Fault Detection, Supervision and Safety of Technical Processes, SAFEPROCESS'2006*, Beijing, China, 2006.
- [26] A.M. Nagy, G. Mourot, B. Marx, J. Ragot, and G. Schutz. Systematic multimodeling methodology applied to an activated sludge reactor model. *Industrial and Engineering Chemistry Research*, 49(6):2790–2799, 2010.

- [27] A.M. Nagy, G. Mourot, B. Marx, G. Schutz, and J. Ragot. Model structure simplification of a biological reactor. In *15th IFAC Symposium on System Identification, SYSID'09*, Saint Malo, France, 2009.
- [28] S.K. Nguang, P. Shi, and S. X. Ding. Fault detection for uncertain fuzzy systems: An LMI approach. *IEEE Transactions on Fuzzy Systems*, 15(6):1251–1262, 2007.
- [29] R.C.L.F. Oliveira, and P.L.D. Peres. Stability of polytopes of matrices via affine parameter-dependent Lyapunov functions: Asymptotically exact LMI conditions. *Linear Algebra and its Applications*, 405:209–228, 2005.
- [30] R. Orjuela. *Contribution à l'estimation d'état et au diagnostic des systèmes représentés par des multimodèles*. PhD thesis, Institut National Polytechnique de Lorraine (INPL), Nancy, France, 2008. (in french).
- [31] R. Orjuela, B. Marx, J. Ragot, and D. Maquin. State estimation for non-linear systems using a decoupled multiple model. *International Journal of Modelling, Identification and Control*, 4(1):59–67, 2008.
- [32] R. Patton, P. Frank, and R. Clark. *Fault Diagnosis in Dynamic Systems: Theory and Application*. Prentice Hall international, 1989.
- [33] S. Raghavan and J.K. Hedrick. *Observer design for a class of nonlinear systems*. *International Journal of Control*, 59: 515–528, 1994.
- [34] A. Sala, and C. Ariño. Asymptotically necessary and sufficient conditions for stability and performance in fuzzy control: Applications of Polyá's theorem. *Fuzzy Sets and Systems*, 158(24):2671–2686, 2007.
- [35] J. Stoustrup, and H. Niemann. Application of an  $H_\infty$  based FDI and control scheme for the three tank system. In *4th IFAC Symposium on Fault Detection, Supervision and Safety for Technical Processes, SAFEPROCESS'2000*, Budapest, Hungary, 2000.
- [36] J. Stoustrup, and H. Niemann. Fault estimation – a standard problem approach. *International Journal of Robust and Nonlinear Control*, 12(8):649–673, 2002.
- [37] X. Su, P. Shi, L. Wu, and Y.D. Song. A novel approach to filter design for TS fuzzy discrete-time systems with time-varying delay. *IEEE Transactions on Fuzzy Systems*, 20(6), 1114-1129, 2012
- [38] T. Takagi, and M. Sugeno. Fuzzy identification of systems and its applications to modeling and control. *IEEE Transactions on Systems, Man and Cybernetics*, 15(1):116–132, 1985.
- [39] M. Takahashi. Self-repairing and adaptive control of MIMO systems with faulty sensors. *International Journal of Innovative Computing, Information and Control*, 5(10B):3573–3582, 2009.

- [40] K. Tanaka, T. Hori, and H.O. Wang. A multiple Lyapunov function approach to stabilization of fuzzy control systems. *IEEE Transactions on Fuzzy Systems*, 11(4):582–589, 2003.
- [41] K. Tanaka, T. Ikeda, and H.O. Wang. Robust stabilization of a class of uncertain nonlinear systems via fuzzy control: quadratic stabilizability,  $H_\infty$  control theory, and linear matrix inequalities. *IEEE Transactions on Fuzzy Systems*, 4(1):1–13, 1996.
- [42] K. Tanaka, T. Ikeda, and H.O. Wang. Fuzzy regulators and fuzzy observers: Relaxed stability conditions and LMI-based designs. *IEEE Transactions on Fuzzy Systems*, 6(2):250–265, 1998.
- [43] K. Tanaka, and H.O. Wang. *Fuzzy Control Systems Design and Analysis: A Linear Matrix Inequality Approach*. John Wiley and Sons, 2001.
- [44] H.D. Tuan, P. Apkarian, T. Narikiyo, and Y. Yamamoto. Parameterized linear matrix inequality techniques in fuzzy control system design. *IEEE Transactions on Fuzzy Systems*, 9(2):324–332, 2001.
- [45] J. Wang, B. Jiang, and P. Shi. Adaptive observer based fault diagnosis for satellite attitude control system. *International Journal of Innovative Computing, Information and Control*, 4(8):1921–1929, 2008.
- [46] Y. Wang, W. Wang, and D. Wang. LMI approach to design fault detection filter for discrete-time switched systems with state delays. *International Journal of Innovative Computing, Information and Control*, 6(1):387–397, 2010.
- [47] J. Yoneyama.  $H_\infty$  filtering for fuzzy systems with immeasurable premise variables: an uncertain system approach. *Fuzzy Sets and Systems*, 160(12):1738–1748, 2009.
- [48] Y. Zhao, J. Lam, and H. Gao. Fault detection for fuzzy systems with intermittent measurements. *IEEE Transactions on Fuzzy Systems*, 17(2):398–410, 2009.