



HAL
open science

Cross-sections to semi-flows on 2-complexes

François Gautero

► **To cite this version:**

François Gautero. Cross-sections to semi-flows on 2-complexes. Ergodic Theory and Dynamical Systems, 2003, 23 (1), pp.143-174. hal-00807127

HAL Id: hal-00807127

<https://hal.science/hal-00807127>

Submitted on 3 Apr 2013

HAL is a multi-disciplinary open access archive for the deposit and dissemination of scientific research documents, whether they are published or not. The documents may come from teaching and research institutions in France or abroad, or from public or private research centers.

L'archive ouverte pluridisciplinaire **HAL**, est destinée au dépôt et à la diffusion de documents scientifiques de niveau recherche, publiés ou non, émanant des établissements d'enseignement et de recherche français ou étrangers, des laboratoires publics ou privés.

Cross-sections to semi-flows on 2-complexes

François Gautero

e-mail: Francois.Gautero@agat.univ-lille1.fr

Université de Lille I

Laboratoire A.G.A.T., U.M.R. C.N.R.S. 8524

59655 Villeneuve d'Ascq, Cedex, France

April 3, 2013

Abstract: *A dynamical 2-complex is a 2-complex equipped with a set of combinatorial properties which allow to define non-singular semi-flows on the complex. After giving a combinatorial characterization of the dynamical 2-complexes which define hyperbolic attractors when embedded in compact 3-manifolds, one gives an effective criterion for the existence of cross-sections to the semi-flows on these 2-complexes. In the embedded case, this gives an effective criterion of existence of cross-sections to the associated hyperbolic attractors. We present a similar criterion for boundary-tangent flows on compact 3-manifolds which are constructed by means of our dynamical 2-complexes.*

Introduction

The theme of searching cross-sections to flows on manifolds, or semi-flow on complexes, is an old theme. We refer for instance the reader to [16], [8] or [6]. However, it is not so easy in practice to apply the criteria of these papers and effectively find a cross-section to a given flow or semi-flow. For instance, even in the case where one is given a Markov partition of some non-singular flow, Fried's criterion ([6]) only applies to prove the existence, or non-existence, of a cross-section *in a given cohomology-class*. If the rank of the first homology group of the ambient manifold M is strictly greater than one, this forces to check an *infinite number* of cohomology-classes. Assuming that one can restrict to check only a finite set of such classes, for instance, in the case where M is 3-dimensional, by using the structure given by the Thurston's semi-norm (see [18] or [7]) of the first homology group of M , one still has to compute all the *minimal periodic orbits* ([6]) of the flow. These orbits are those which cross at most once each box of the Markov partition. Thus, if one has n boxes, their number might be as large as $\sum_{j=1}^n \frac{n!}{j!(n-j)!}$. Moreover, computing the unit-ball of the Thurston's semi-norm is not, a priori, a so easy exercise.

In this work the emphasis is more on semi-flows rather than on flows. Very recent papers show a renew of interest in this kind of dynamics (see [11] and the references cited therein). Considering non-singular semi-flows on *dynamical 2-complexes* as introduced in [9], one will take advantage of the combinatorial nature of these objects to give an effective criterion for the existence of cross-sections to the semi-flows and flows constructed by means of these complexes. Roughly speaking, the dynamical 2-complexes are *special polyhedra* (see

[12] - these are polyhedra whose points admit neighborhoods of certain types, illustrated in figure 1) equipped with an orientation of the 1-cells satisfying two simple combinatorial properties. These conditions of orientation of the 1-cells allow to define non-singular semi-flows on these 2-complexes, by giving in some sense the orientation of the semi-flow in a neighborhood of the 1-skeleton. These semi-flows are called *combinatorial semi-flows*. The criterion of existence of cross-sections we establish here relies on the existence of certain *non-negative cocycles in $C^1(K; \mathbf{Z})$* , namely *nice non-negative cocycles* (see definition 5.1). The search of these cocycles is done by searching for the non-negative integer solutions of $\delta^1 X = 0$, where $\delta^1: C^1(K; \mathbf{Z}) \rightarrow C^1(K; \mathbf{Z})$ is the first co-boundary operator of the complex. This system is a linear system of equations with integer coefficients, and thus the set of non-negative integer solutions is generated by a finite number of them. This implies the finiteness of our process. Furthermore, the number of equations and unknowns of the above system depends only *linearly* on the number of 1-cells in the singular set, that is the set of points where the complex is not a manifold. For more details on the effectivity of the given criterion, we refer the reader to [9]: Although this paper deals with an other type of cocycles, the case of nice non-negative cocycles is handled similarly.

Let us now be more precise on our results. For the sake of simplicity and brevity, we did not intent to establish criteria of existence of cross-sections for the whose class of dynamical 2-complexes, but essentially for an important case, i.e. when the dynamical 2-complex admits, in a compatible way, a structure of *dynamic branched surface* as defined by Christy (see [3]). It is then called a *special dynamic branched surface* (see definition 3.2). We give here a combinatorial and effective criterion for a dynamical 2-complex to admit such a structure (proposition 3.7). We refer the reader to [9] for a more complete discussion about the relationships between dynamical 2-complexes and dynamic branched surfaces. Let us recall that branched surfaces, introduced by Williams in [19], are 2-complexes equipped with a smooth structure. Dynamic branched surfaces are branched surfaces carrying non-singular semi-flows. They were introduced by Christy for the study of *hyperbolic attractors* in 3-dimensional manifolds. We refer the reader to [17, 5, 3] among others for basic notions of hyperbolic dynamics. Our result is the following one (section 5):

Theorem 0.1 *An efficient semi-flow on a special dynamic branched surface W admits a cross-section if and only if there exists a nice non-negative cocycle $u \in C^1(K; \mathbf{Z})$. Any such cocycle defines a cross-section to any efficient semi-flow on W .*

Efficient semi-flows form a particular class of combinatorial semi-flows, they are everywhere transverse to the singular set of the branched surface. They so belong to the class of semi-flows on dynamic branched surfaces defined by Christy in [3]. Roughly speaking, in the work of Christy, a dynamic branched surface is obtained from a hyperbolic attractor by cutting along the stable foliation of the hyperbolic flow, and then identifying any two points lying on a same stable segment. One says that the hyperbolic attractor *collapses* to the dynamic branched surface. In this “embedded case” theorem 0.1 above implies the following corollary (see section 7):

Corollary 0.2 *If an hyperbolic attractor in a compact 3-manifold collapses to a special dynamic branched surface, then the corresponding hyperbolic flow admits a cross-section if and only if there exists a positive cocycle $u \in C^1(K; \mathbf{Z})$. Any such cocycle defines a cross-section to this hyperbolic flow.*

Indeed, if a dynamical 2-complex K is the spine ([12]) of a compact 3-manifold M_K (this is a *dynamical 2-spine*), then, for any combinatorial semi-flow $(\sigma_t)_{t \in \mathbf{R}^+}$ on K , there is a non-singular flow $(\phi_t)_{t \in \mathbf{R}^+}$ on M_K , transverse to ∂M_K and pointing inward, which is semi-conjugated to $(\sigma_t)_{t \in \mathbf{R}^+}$. The retraction of the manifold onto the complex plays the role of the semi-conjugacy. This fact is well-known in the context of branched surfaces. Let us observe that the nature of the cocycles involved changes from theorem 0.1, “nice non-negative cocycles”, to corollary 0.2, “positive cocycles”. A positive cocycle is in particular a nice non-negative cocycle, and thus corollary 0.2 sharpens our result in the embedded case. This is due to the fact that the cross-sections we find in theorem 0.1 might miss some positive loops in the singular graph (where “positive” refers here to the orientation put on the edges in the definition of dynamical 2-complex), which are not necessarily homotopic to periodic orbits of the semi-flow in the general case, but which are in the embedded case. These are the so-called “boundary periodic orbits” in the work of Christy (see [5, 3]). We give a proof of corollary 0.2 without using this knowledge on the periodic orbits of hyperbolic flows.

Speaking of cross-sections leads to think to the mapping-torus or suspension operation. This construction, when applied to a homeomorphism of a compact surface with boundary, gives a 3-dimensional manifold, together with a non-singular flow *tangent* to the boundary and admitting a cross-section. In the Appendix (section 8), we show how to define boundary-tangent flows from dynamical 2-spines. We prove that the existence of a positive cocycle again is a necessary and sufficient criterion of existence of cross-section to these flows. Let us observe that this is no more true if, instead of considering boundary-tangent flows, one considers flows transverse to the boundary of the manifold, as in the case of special dynamic branched surface, but the dynamical 2-complex considered is not a dynamic branched surface.

Acknowledgements: Some of this work comes from the doctoral dissertation of the author, written under the direction of J. Los. During the elaboration of the paper, the author benefited of a European Marie Curie Grant, and is very grateful toward the Centre de Recerca Matemàtica and the Departament de Matemàtiques of the Universitat Autònoma de Barcelona, particularly its Dynamical Systems team, for their hospitality.

1 Flat and dynamical 2-complexes

All the complexes considered in this paper will be piecewise-linear and, unless otherwise stated, connected, and compact. The j -skeleton $K^{(j)}$ of a n -dimensional CW-complex K ($0 \leq j \leq n$) is the union of all the cells in K whose dimension is less or equal to j . Let us recall that each i -cell C , $1 \leq i \leq n$, comes with an attaching-map h_C which is a continuous map from its boundary (this is a $(i-1)$ -sphere - S^0 consists of two points) to the complex. We will not distinguish between the boundary of C and its image in the complex under this attaching-map h_C , both denoted by ∂C , but leave to the reader the (easy) task to know in each occurrence what designates the symbol ∂C .

We will denote by $Con(X)$ the cone over a space X , that is the space $X \times [0, 1]$, where $X \times \{1\}$ is identified to a single point. Finally, we denote by Δ^3 the closed 3-dimensional simplex.

The 0-cells (resp. 1-cells) of a CW-complex are called the *vertices* (resp. *edges*) of the complex. If e is an oriented edge, then e is said to be an *incoming edge* at its *terminal vertex* $t(e)$ and an *outgoing edge* at its *initial vertex* $i(e)$. Let us observe that an oriented

edge e can be both incoming and outgoing at a same vertex, if this edge is a loop. A *graph* is a 1-dimensional CW-complex.

We call *path* (resp. *loop*) in a topological space X a locally injective continuous map from the interval (resp. circle) to X . Let us observe that a loop in a graph, or a path between two vertices in a graph, defines and is defined by a word in the edges of the graph. This word is unique for a path, and unique up to a cyclic permutation for a loop. We will denote by $L(p)$ (resp. $F(p)$) the last (resp. first) edge intersected by a path p in a graph Γ . A path or loop in Γ is *positive* (resp. *negative*) if it is oriented such that its orientation agrees (resp. disagrees) at any point with the orientation of the edges that it intersects.

1.1 Basic definitions

We first recall the notions of *standard complex* introduced by Casler (see [2] and also [12, 1]), and the derived notion of *flat 2-complex* (see [9]).

Following [12], we call *special 2-polyhedron* a piecewise-linear 2-complex satisfying the following property: For any point $x \in K$, there is a neighborhood $N(x)$ of x in K , a neighborhood $N(y)$ of a point y in the interior of $\text{Con}((\partial\Delta^3)^{(1)})$, and a homeomorphism $h_x: N(x) \rightarrow N(y)$ such that $h_x(x) = y$.

Let K be a special 2-polyhedron. The *singular graph* $K_{\text{sing}}^{(1)}$ is the closure in K of the set of points x whose image under h_x belongs to an open 1-cell of the interior of $\text{Con}((\partial\Delta^3)^{(1)})$. The set of *crossings* $K_{\text{sing}}^{(0)}$ is the set of points x of K such that $h_x(x)$ is the base of $\text{Con}((\partial\Delta^3)^{(1)})$. We set $K_{\text{sing}}^{(2)} = K$. The connected components of $K_{\text{sing}}^{(m+1)} - K_{\text{sing}}^{(m)}$, $0 \leq m \leq 1$, are called the $(m+1)$ -*components* of the complex (the 0-components are the crossings).

With this terminology, a *standard 2-complex*, as defined by Casler, is a special 2-polyhedron whose all 2-components are 2-cells. We will call *flat 2-complex* a special 2-polyhedron whose 2-components are either 2-cells, annuli or Moebius-bands.

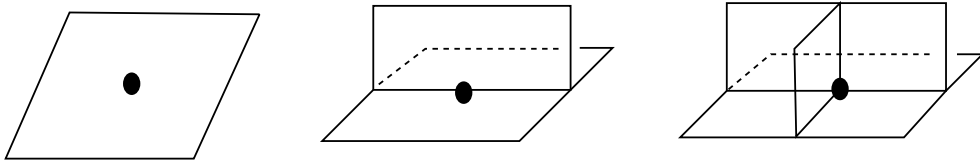

Figure 1: Non-singular and singular points in flat 2-complexes

Remark 1.1 By definition of a special polyhedron K , there is exactly one 2-component of K incident to any turn of edges in the singular graph of K . If (e, e') is the turn considered, we will denote by $D(e, e')$ this 2-component.

Important: Let K be any flat 2-complex. Then K admits a canonical structure of CW-complex defined as follows: The vertices are the crossings of the complex, together with a set of valency 2-vertices, one for each connected component of $K_{\text{sing}}^{(1)}$ which is a loop without any crossing. The edges are the 1-components of the complex, together with a set of valency 2 edges, one in each 2-component which is not a disc. We will always assume that our flat 2-complexes K are equipped with this canonical structure of CW-complex, and

their singular graph $K_{sing}^{(1)}$ with the induced structure. In particular, the edges of $K_{sing}^{(1)}$ are the 1-components of K . This causes no loss of generality for our purpose.

Let K be a flat 2-complex, together with an orientation on the edges of the singular graph. Let C be any 2-component or 2-cell of K . We will say that C contains an *attractor* (resp. a *repellor*) in its boundary if there is a crossing v of K and a germ $g_v(C)$ of C at v such that the two germs of edges of $K_{sing}^{(1)}$ at v contained in $g_v(C)$ are incoming (resp. outgoing) at v . We will say that the crossing v above *is* or *gives rise to* an attractor (resp. a repellor) for C (and for the given orientation).

Definition 1.2 A *flat dynamical 2-complex* is a flat 2-complex K together with an orientation on the edges of the singular graph $K_{sing}^{(1)}$ satisfying the following two properties:

1. Each crossing of K is the initial crossing of exactly 2 edges of $K_{sing}^{(1)}$.
2. Any 2-component which is a 2-cell has exactly one attractor and one repellor for this orientation in its boundary. The other components have no attractor and no repellor in their boundary.

A *standard dynamical 2-complex* is a flat dynamical 2-complex which is also a standard 2-complex.

Lemma 1.3 ([9])

Let K be a flat dynamical 2-complex. The boundary circles of the annulus and Moebius-band components are positive loops in $K_{sing}^{(1)}$. The boundary circle of a disc component D decomposes as pq^{-1} where p and q are two positive paths in $K_{sing}^{(1)}$ with initial point the repellor of D and with terminal point its attractor. They are called the ∂ -positive paths of D .

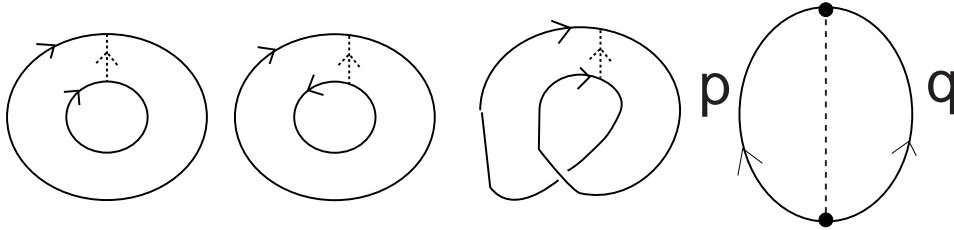

Figure 2: 2-components in a dynamical 2-complex

Remark 1.4 There are two kinds of annulus components in a flat dynamical 2-complex. The annulus components whose orientations of the boundary loops agree are called *coherent*, whereas the others are *incoherent annulus components*.

We will need the analog, for flat 2-complexes, of the notion of a surface embedded in a 3-manifold. This will be the role played by the *r-embedded graphs* defined below.

Definition 1.5 A graph *r-embedded in a flat 2-complex* K is a graph Γ embedded in K transversally to the singular graph $K_{sing}^{(1)}$ and such that:

- The vertices of Γ belong to the interior of the edges of $K_{sing}^{(1)}$ and its edges are disjointly embedded in the 2-components of K .
- If $v \in V(\Gamma)$ belongs to $e \in K_{sing}^{(1)}$, then there is exactly one germ of edge of Γ at v embedded in each germ of 2-cell of K at e .

See figure 3.

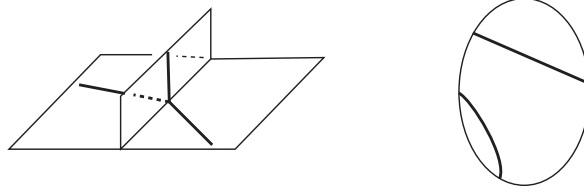

Figure 3: A r-embedding

A graph Γ r-embedded in K is *2-sided* if it has a neighborhood homeomorphic to the trivial I-bundle $\Gamma \times [-1, 1]$, with Γ identified to $\Gamma \times \{0\}$. One always will assume a 2-sided graph to be transversely oriented.

1.2 Homology of flat 2-complexes

Let us remind that the singular graph $K_{sing}^{(1)}$ of a flat 2-complex K is always assumed to be equipped with a structure of CW-complex whose 0-cells are the crossings of K , together with a set of valency 2-vertices in the loops containing no crossing, and whose 1-cells are the 1-components of K . Furthermore, these edges and vertices of $K_{sing}^{(1)}$ are the only edges and vertices of K contained in $K_{sing}^{(1)}$.

If Γ is a graph, an *integer cocycle* of Γ is a collection of integer weights, positive, negative or null, on the edges of Γ . If K is a flat 2-complex, an *integer cocycle* of K is a cocycle in $C^1(K; \mathbf{Z})$, i.e. an integer cocycle of the 1-skeleton of K such that the algebraic sum of its weights along the boundary of the 2-cells is zero.

Lemma 1.6 ([9])

If K is a flat 2-complex, then any integer cocycle $u \in C^1(K; \mathbf{Z})$ defines a graph Γ_u r-embedded and 2-sided in K . The converse is true.

For each edge e of the 1-skeleton, the value $u(e)$ is the number of vertices of Γ_u in e , each with a weight of $+1$ or -1 according to $u(e) > 0$ or $u(e) < 0$. One so obtains a collection of weighted points in the boundary of each 2-cell. These weighted points can be connected by arcs disjointly embedded in the 2-cells and whose transverse orientation agrees (resp. disagrees) at their extremities with the orientation of the corresponding edges of the 1-skeleton if the sign of the considered weighted point is positive (resp. negative). Conversely, any graph r-embedded and 2-sided in a flat 2-complex is easily proved to define an integer cocycle in $C^1(K; \mathbf{Z})$. \diamond

Definition 1.7 A *directed graph* Γ is a graph equipped with an orientation on its edges such that any two vertices are connected by a positive path.

A *non-negative* cocycle in $C^1(\Gamma; \mathbf{Z})$ is an integer cocycle u such that $u(e) \geq 0$ holds for any edge $e \in \Gamma$.

A *non-negative* cohomology class of Γ is a cohomology-class $c \in H^1(\Gamma; \mathbf{Z})$ such that $c(l) \geq 0$ holds for any positive embedded loop l in Γ .

The following lemma is straightforward and explains why we introduced the notion of directed graph.

Lemma 1.8 *Let K be a flat dynamical 2-complex. The singular graph of K , equipped with the orientation on its edges which makes K a flat dynamical 2-complex, satisfies that each of its connected components is a directed graph.*

Definition 1.9 Let K be a flat dynamical 2-complex.

A *non-negative* cocycle of K is an integer cocycle $u \in C^1(K; \mathbf{Z})$ which defines a non-negative, non-null cocycle of the singular graph $K_{sing}^{(1)}$.

A *non-negative* cohomology class of K is a cohomology-class $c \in H^1(K; \mathbf{Z})$ which defines a non-negative, non-null cohomology-class of the singular graph $K_{sing}^{(1)}$.

Remark 1.10 It might be worth noticing that the notion of non-negative cocycle, or non-negative cohomology-class, of a flat dynamical 2-complex is required to be non-negative only on the singular graph, and not on the whole 1-skeleton.

Any non-negative integer cocycle defines a non-negative cohomology class. The converse is true, as shown by proposition 1.13 below. Let us stress that this proposition, and more precisely its corollary 1.17, plays a crucial role in the proof of our main result (theorem 5.2). Before stating it we need an additional definition.

Definition 1.11 Let Γ be a graph. Let v be any vertex of Γ .

We will call *pushing-map* $\mu_v: C^1(\Gamma; \mathbf{Z}) \rightarrow C^1(\Gamma; \mathbf{Z})$ the map defined by:

$(\mu_v(u))(e) = u(e)$ if e is any 1-cell which either is not incident to v or is both incoming and outgoing at v , $(\mu_v(u))(e) = u(e)+1$ if e is incoming, not outgoing at v , $(\mu_v(u))(e) = u(e)-1$ if e is outgoing, not incoming at v .

We will denote by μ_v^k the composition of k pushing-maps μ_v .

Remark 1.12 Clearly, the image of an integer cocycle u of a graph Γ under any pushing-map is an integer cocycle of Γ in the same cohomology class than u . Furthermore, if Γ is the 1-skeleton of a flat dynamical 2-complex K , then the image of an integer cocycle of K under a pushing-map also is an integer cocycle of K in the same cohomology-class.

Proposition 1.13 *Let Γ be a directed graph. If u is any integer cocycle of Γ in a non-negative cohomology-class, then some finite sequence of pushing-maps transforms u to a non-negative cocycle in the same cohomology-class.*

Proof of proposition 1.13: To prove this proposition, we need first to introduce some terminology. Let \mathcal{T} be a tree together with an orientation on its edges. \mathcal{T} is a *rooted tree* if there is exactly one vertex v in \mathcal{T} whose all incident edges are outgoing edges. This vertex v is the *root* of \mathcal{T} . The *ends* of a rooted tree \mathcal{T} are the vertices with exactly one

incident edge. These edges are the *terminal edges* of \mathcal{T} (since \mathcal{T} is a rooted tree, each terminal edge is an incoming edge at the corresponding end).

Let $\mathcal{T} = \pi^{-1}(\Gamma)$ be the universal covering of Γ (π is the associated covering-map). This is an infinite tree. The edges of \mathcal{T} inherit an orientation from the orientation of the edges of Γ .

Let $u \in C^1(\Gamma; \mathbf{Z})$ be any integer cocycle in a non-negative cohomology class. If u is a non-negative cocycle there is nothing to prove. Let us thus assume that u is not a non-negative cocycle.

Let e be any edge of Γ such that $u(e) < 0$. Let e_0 be any edge of \mathcal{T} with $\pi(e_0) = e$. One defines inductively a sequence $\mathcal{T}_0 \subset \mathcal{T}_1 \subset \dots \subset \mathcal{T}_i \subset \dots$ of rooted trees $\mathcal{T}_i \subset \mathcal{T}$ with root v_0 , and a sequence of integer cocycles $u_0, u_1, \dots, u_i, \dots$ of $C^1(\Gamma; \mathbf{Z})$ in the following way:

$\mathcal{T}_0 = e_0$, $u_0 = u$.

For $i = 1, 2, \dots$: Let $v_1^{i-1}, \dots, v_k^{i-1}$ be a maximal (in the sense of the inclusion) set of ends of \mathcal{T}_{i-1} such that:

- $\pi(v_j^{i-1}) \neq \pi(v_k^{i-1})$ if $j \neq k$.
- If x_j is the terminal edge of \mathcal{T}_{i-1} incident to v_j^{i-1} , then

$$m_j = |u_{i-1}(\pi(x_j))| = \max\{|u_{i-1}(\pi(x))|, x \text{ is a terminal edge of } \mathcal{T}_{i-1}, \pi(t(x)) = \pi(v_j^{i-1})\}.$$

$u_i = (\mu_{v_1^{i-1}}^{m_1} \circ \dots \circ \mu_{v_k^{i-1}}^{m_k})(u_{i-1})$.

\mathcal{T}_i is the union of \mathcal{T}_{i-1} with the edges x of \mathcal{T} whose initial vertex is one of the ends v_1^i, \dots, v_k^i of \mathcal{T}_{i-1} and such that $u_i(\pi(x)) < 0$.

Lemma 1.14 *Let $i \geq 1$ such that \mathcal{T}_{i-1} is a proper subset of \mathcal{T}_i . Then for any positive path $e_0 e_1 \dots e_i$ with $e_j \in \mathcal{T}_j$, for any $0 \leq j \leq i$, $\pi^* u_i(e_j \dots e_i) < 0$.*

Proof of lemma 1.14: We proceed by induction on i . For $i = 1$: Since u_0 is in a non-negative cohomology-class and by assumption $\pi^* u_0(e_0) < 0$, the edge e_0 is not a loop and thus has distinct initial and terminal vertices. Therefore, since u_1 is obtained from u_0 by applying a pushing-map at the terminal vertex of e_0 , $\pi^* u_1(e_0) = 0$. By construction the values of u_i on the terminal edges of \mathcal{T}_i are negative. The assertion is thus satisfied for $i = 1$.

Let us assume that it is satisfied until i , that is for any positive path $e_0 e_1 \dots e_i$ with $e_j \in \mathcal{T}_j$, for any $0 \leq j \leq i$, $\pi^* u_i(e_j \dots e_i) < 0$. One wants to prove that this property is still true at $i + 1$.

Let us consider a positive path $e_0 e_1 \dots e_{i+1}$. By construction $\pi^* u_{i+1}(e_{i+1}) < 0$. Furthermore as for $\pi^* u_1(e_0)$, and since all the ends of \mathcal{T}_i have distinct images under π , $\pi^* u_{i+1}(e_i)$ is zero. Since the cohomology-class of u_i is non-negative, and by the hypothesis of induction, the terminal vertex of e_i , which is the initial vertex of e_{i+1} , is distinct from all the initial vertices of e_0, e_1, \dots, e_i . If the terminal vertex of e_i is the only end of \mathcal{T}_i , this observation implies $\pi^* u_{i+1}(e_j) = \pi^* u_i(e_j)$ for $j = 0, \dots, i-1$. The hypothesis of induction, together with the remarks above on $\pi^* u_{i+1}(e_i)$ and $\pi^* u_{i+1}(e_{i+1})$, allows to conclude. Let us thus assume that \mathcal{T}_i has other ends than $t(e_i)$. If the image under π of these ends is

distinct from the image under π of the initial vertices of the e_j , $j \leq i$, then the conclusion is obvious. If the image under π of one of these ends is the same than the image of some $i(e_j)$, $j \leq i$, then the pushing-map $\mu_{\pi(i(e_j))}^k$ applied at this vertex increases the value of u_i on e_{j-1} by k and decreases the value of u_i on all the outgoing edges at $i(e_j)$, and in particular on e_j , by k . Therefore $\pi^*u_{i+1}(e_j \cdots e_{i+1}) < 0$ still holds. This completes the proof of the induction, and so the proof of lemma 1.14. \diamond

Corollary 1.15 *There exists an integer $k \geq 1$ such that $\mathcal{T}_n = \mathcal{T}_k$ and $u_n = u_k$ for any $n \geq k$.*

Proof of corollary 1.15: We set M the number of vertices in Γ . If $\mathcal{T}_{M+1} \neq \mathcal{T}_M$ then lemma 1.14 says that π^*u_{M+1} is negative on any positive path $e_j \cdots e_{M+1}$. Since $M+1$ is strictly greater than the number of vertices of Γ , for some integer j , $i(e_j) = t(e_{M+1})$. Then $\pi(e_j \cdots e_{M+1})$ is a loop l with $u_{M+1}(l) < 0$. This is a contradiction with the fact that the cohomology-class of u , and thus of u_{M+1} , is non-negative. The corollary follows. \diamond

Lemma 1.16 *Let k be the integer given by corollary 1.15.*

1. *The cocycle u_k is non-negative on the edge $\pi(e_0) = e$.*
2. *If $u_k(x) < 0$ for some edge x of Γ , then $u(x) < 0$.*

Proof of lemma 1.16: The cocycle u_1 is non-negative on the edge $\pi(e_0)$ (see the beginning of the proof of lemma 1.14. If no non-negative cocycle u_i takes a negative value on $\pi(e_0)$, there is nothing to prove. If some u_j satisfies $u_j(\pi(e_0)) < 0$ then \mathcal{T}_j is a proper subset of \mathcal{T}_{j+1} . Since for $n \geq k$ $\mathcal{T}_n = \mathcal{T}_k$, $u_k(\pi(e_0)) \geq 0$. Item (1) is proved. $\diamond \diamond$

Corollary 1.17 *Let K be a flat dynamical 2-complex. Any non-negative cohomology class in $H^1(K; \mathbf{Z})$ is represented by a non-negative cocycle in $C^1(K; \mathbf{Z})$.*

This is a straightforward consequence of proposition 1.13 and of lemma 1.8. It suffices to apply the sequence of pushing-maps given by proposition 1.13 to the 1-skeleton of K . \diamond

1.3 Non-singular semi-flows

Definition 1.18 A non-singular semi-flow on a flat dynamical 2-complex K is a one parameter family $(\sigma_t)_{t \in \mathbf{R}_+}$ of continuous maps of the complex, which depends continuously on the parameter t , such that $\sigma_0 = Id_K$, $\sigma_{t+t'} = \sigma_t \circ \sigma_{t'}$, and satisfying the following properties:

- No point of K is fixed by the whole family.
- It defines a C^∞ non-singular flow in restriction to each 2-component.

Definition 1.19 A *cross-section* to a non-singular semi-flow on a flat dynamical 2-complex is a 2-sided, r -embedded graph which intersects transversally, positively, and in finite time, all the orbits of the semi-flow.

In what follows, the *triangle* T denotes the cone, based at the origin $(0, 0)$ of the oriented plane \mathbf{R}^2 , over the interval $y = 1 - x$, $x \in [0, 1]$. The *rectangle* R is the square $[0, 1] \times [0, 1]$. The *model-flow on T* (resp. on R) is the restriction to T (resp. to R) of the non-singular flow on \mathbf{R}^2 whose orbits are the lines $y = \mu - x$, $\mu \in [0, 1]$ (resp. the lines $x = \mu$, $\mu \in [0, 1]$).

Definition 1.20 A *combinatorial semi-flow* on a flat dynamical 2-complex K is a non-singular semi-flow on K satisfying the following properties:

1. There is a decomposition of K in a finite number of triangular and rectangular boxes whose boundary-points are pre-periodic under the semi-flow and such that the semi-flow in restriction to each box is topologically conjugate to the corresponding model-flow.
2. The orientation of the semi-flow agrees, in a neighborhood of the singular graph $K_{sing}^{(1)}$, with the orientation of the edges of $K_{sing}^{(1)}$.
3. In each disc component, an orbit-segment connects the repeller to the attractor.
4. Let X be a 2-component which is either a coherent annulus component or a Moebius-band. Then the semi-flow is transverse to the rays of X and the core of X is a periodic orbit.

Remark 1.21 The orbit-segment which connect in each disc component the repeller to the attractor will be called *separating orbit-segment*. The union of all the separating orbit-segments is a collection of periodic orbits of the combinatorial semi-flow considered. These orbits will be called *separating orbits*. Each crossing belongs to exactly one separating orbit. In particular, the crossings are periodic under any combinatorial semi-flow.

Lemma 1.22 ([9])

Any flat dynamical 2-complex K carries a combinatorial semi-flow.

We will call *properly embedded orbit-segment* of a non-singular semi-flow $(\sigma_t)_{t \in \mathbf{R}^+}$ on a flat dynamical 2-complex K an orbit-segment of $(\sigma_t)_{t \in \mathbf{R}^+}$ whose endpoints, if any, are in the boundaries of some 2-components of K , and which is transverse to these boundaries at these endpoints.

Lemma 1.23 ([9])

Let K be a flat dynamical 2-complex. Any properly embedded orbit-segment of any combinatorial semi-flow on K is homotopic, relative to its endpoints if any, to a positive path in the singular graph of K .

Proposition 1.24 ([9])

Any non-negative cocycle $u \in C^1(K; \mathbf{Z})$ of a flat dynamical 2-complex K defines, for any combinatorial semi-flow $(\sigma_t)_{t \in \mathbf{R}^+}$ on K , a r -embedded graph Γ_u transverse to $(\sigma_t)_{t \in \mathbf{R}^+}$.

2 From semi-flows to flows on 3-manifolds

We recall below the definition of a spine of a manifold (see for instance [1, 2, 12]).

Definition 2.1 A flat n -complex K ($n = 1, 2$) is the *spine* of a compact $(n + 1)$ -manifold with boundary M_K if there is an embedding $i: K \rightarrow M_K$ and a retraction $r_{M_K}: M_K \rightarrow i(K)$, which is a homotopy equivalence, such that the manifold M_K is homeomorphic to $\partial M_K \times [0, 1]$ quotiented by the equivalence relation $(x, t) \sim (x', t')$ if and only if $t = t' = 0$ and $r_{M_K}(x) = r_{M_K}(x')$. The fibers $r_{M_K}^{-1}(x)$ are $(n + 2 - j)$ -ods centered at x , where j is the smallest integer for which $x \in K_{sing}^{(j)}$.

If K is a flat 2-complex, figure 4 shows the pre-image under r_{M_K} of a neighborhood in K of each of the two types of singular points.

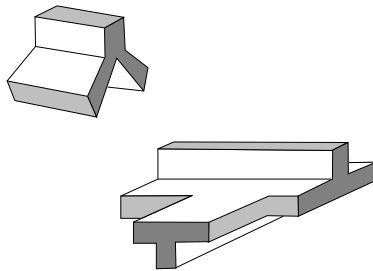

Figure 4: Thickening of flat 2-complexes

A flat dynamical 2-complex which is the spine of some compact 3-manifold will be called a *flat dynamical 2-spine*.

Remark 2.2 At the difference of the standard spines of Casler or the special spines of Matveev, we admit 2-components which are not 2-cells. Thus two non-homeomorphic $(n + 1)$ -manifolds can admit homeomorphic flat 2-spines.

Proposition 2.3 below treats the problem of reconstructing a non-singular flow on the manifold M_K from a combinatorial semi-flow on a dynamical 2-spine K .

Proposition 2.3 *Let K be a flat dynamical 2-spine of a 3-manifold M_K . Then, for any combinatorial semi-flow $(\sigma_t)_{t \in \mathbf{R}^+}$ on K , there is a non-singular flow $(\phi_t)_{t \in \mathbf{R}^+}$ on M_K , transverse and pointing inward with respect to ∂M_K , such that the retraction $r_{M_K}: M_K \rightarrow K$ given by definition 2.1 defines a semi-conjugacy between $(\phi_t)_{t \in \mathbf{R}^+}$ and $(\sigma_t)_{t \in \mathbf{R}^+}$.*

Proof of proposition 2.3: Let us consider any maximal (in the sense of the inclusion) orbit-segment I_x contained in some triangular or rectangular box for the semi-flow, where x is the initial point of I_x . For each point $y \in r_{M_K}^{-1}(x)$ in the interior of M_K , one defines an interval I_y which projects to I_x under r_{M_K} . The glueing of these oriented intervals defines the orbits of a non-singular flow on $M_K - \partial M_K$ which is semi-conjugated to $(\sigma_t)_{t \in \mathbf{R}^+}$ by r_{M_K} . For each point $x \in K$, for each $y \in r_{M_K}^{-1}(x) \cap \partial M$, one now defines an oriented interval I_y transverse to ∂M_K at y and which projects under r_{M_K} to I_x . One so completes the above flow to a non-singular flow on M_K which is as announced. \diamond

Remark 2.4 Proposition 2.3 above and remark 2.2 imply that two non-singular flows on two 3-manifolds which are semi-conjugated to a same semi-flow on a same dynamical 2-spine are not necessarily topologically conjugated since their ambient manifolds might be not homeomorphic.

Definition 2.5 A *cross-section* to a non-singular flow on a compact 3-manifold M^3 is a surface properly embedded in M^3 , that is with its boundary embedded in ∂M^3 , and which intersects transversely, positively and in finite time all the orbits of the flow.

Proposition 2.6 *With the assumptions and notations of proposition 2.3, any cross-section Γ_u , $u \in C^1(K; \mathbf{Z})$, to a combinatorial semi-flow $(\sigma_t)_{t \in \mathbf{R}^+}$ on K defines a cross-section $S_u = r_{M_K}^{-1}(\Gamma_u)$ to a flow $(\phi_t)_{t \in \mathbf{R}^+}$ on M_K semi-conjugated to $(\sigma_t)_{t \in \mathbf{R}^+}$, as given by proposition 2.3.*

Proof of proposition 2.6: The following lemma is straightforward:

Lemma 2.7 *Let K be a flat 2-spine of a 3-manifold M_K , and let $r_{M_K}: M_K \rightarrow K$ be the retraction given by definition 2.1. Any cocycle $u \in C^1(K; \mathbf{Z})$ defines a surface $S_u = r_{M_K}^{-1}(\Gamma_u)$ properly embedded in M_K .*

By construction of $(\phi_t)_{t \in \mathbf{R}^+}$ (see proposition 2.3), it is clear that, if Γ_u is a cross-section to $(\sigma_t)_{t \in \mathbf{R}^+}$, then the surface $S_u = r_{M_K}^{-1}(\Gamma_u)$ is a cross-section to $(\phi_t)_{t \in \mathbf{R}^+}$. \diamond

Remark 2.8 With the assumptions and notations of lemma 2.7, if $i: K \rightarrow M_K$ denotes the embedding of K in M_K and $[u]$ the cohomology class of u in $H^1(K; \mathbf{Z})$, then $i_{\#}([u])$ is the cohomology class in $H^1(M_K; \mathbf{Z})$ associated to S_u .

3 Special dynamic branched surfaces

Let K be a flat 2-complex or a graph. A *smoothing on K* consists of defining at each point of K a tangent space $T_x K$, which depends continuously on x .

When a smoothing is defined on a graph Γ , a tangent line is in particular defined at each vertex v of Γ (we will say that a *smoothing is defined at v*). There are thus two *sides* at v . If a smoothing is defined at some vertices of a graph Γ , and p is a path in Γ , one says that p is *carried by Γ* if p does not cross any turn of edges which are in the same side of a vertex.

When a smoothing is defined along a path p in the singular graph of a flat 2-complex K , it defines two sides with respect to any interval $I \subset p$ embedded in K . Since there are three germs of 2-cells incident to each point x of I , two points in two distinct germs at x will be on the same side with respect to x . The corresponding germs are said to be in the *locally 2-sheeted side of I at x* . The other side is the *locally 1-sheeted side of I at x* .

Definition 3.1 Let K be a flat dynamical 2-complex, together with a smoothing along a path p in the singular graph $K_{sing}^{(1)}$.

This smoothing is *compatible* with K if, for each embedded interval $I \subset p$, for each crossing v contained in I , exactly two edges in $St_{K_{sing}^{(1)}}(v)$ are oriented from the locally 2-sheeted side of I to the locally 1-sheeted side of I .

Definition 3.2 A *special dynamic branched surface* is a standard dynamical 2-complex which admits a compatible smoothing along its singular graph.

The following lemma comes from the work of Christy (see [3]).

Lemma 3.3 ([3])

Any special dynamic branched surface carries a combinatorial semi-flow transverse to its singular graph \mathcal{S} and going at every point of \mathcal{S} from the locally 2-sheeted side to the locally 1-sheeted side.

Such a semi-flow is called an efficient semi-flow.

In figure 5, we illustrate what looks like, up to diffeomorphism, an efficient semi-flow in a neighborhood of a crossing of a special dynamic branched surface.

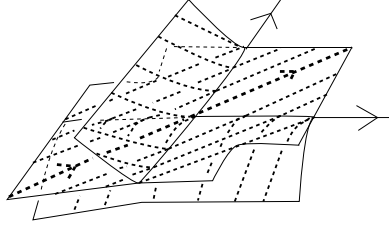

Figure 5: An efficient semi-flow in a neighborhood of a crossing

Definition 3.4 Let W be a special dynamic branched surface.

We will call *corner* of a positive path (or loop) p in the singular graph of W a crossing $v = p(t_0)$ of K in p which is a point of tangency of some efficient semi-flow on W with the interval $[p(t_0 - \epsilon), p(t_0 + \epsilon)]$ for $\epsilon > 0$ sufficiently small.

A positive path (resp. loop) without any corner will be called a *flat path* (resp. a *flat loop*). A flat positive, immersed loop is called a *circuit* of W .

Thus, any flat path either is contained in, or contains, a circuit of W . Any flat loop in the singular graph of a special dynamic branched surface W is a circuit of W , or turns k times along a circuit of W .

In the following lemma, we precise, with the above terminology, the form of the 2-components of a special dynamic branched surface. It comes straightforwardly from the work of Christy in [3] and the preceding definitions.

Lemma 3.5 ([3])

If D is any 2-component of a special dynamic branched surface W , then:

1. Each ∂ -positive path of D (see lemma 1.3) contains exactly one corner, i.e. ∂D admits exactly two points of tangency x_1, x_2 with any efficient semi-flow $(\sigma_t)_{t \in \mathbf{R}^+}$ on W .
2. In particular, $\partial D \setminus \{x_1, x_2\}$ decomposes in two connected components such that $(\sigma_t)_{t \in \mathbf{R}^+}$ is incoming in D with respect to one of them and outgoing of D with respect to the other. In other words, D is in the locally 1-sheeted side of the first connected component, and in the locally 2-sheeted side of the other.
3. The connected component along which $(\sigma_t)_{t \in \mathbf{R}^+}$ is incoming in D is the union of the two outgoing edges at some crossing of W , which is the repeller of D .
4. The connected component along which $(\sigma_t)_{t \in \mathbf{R}^+}$ is outgoing of D is the union of two flat paths, one in each ∂ -positive path of D , from x_1 (resp. x_2) to the crossing of W which is the attractor of D . These two flat paths are called the flat 2-sides of D .

See figure 6.

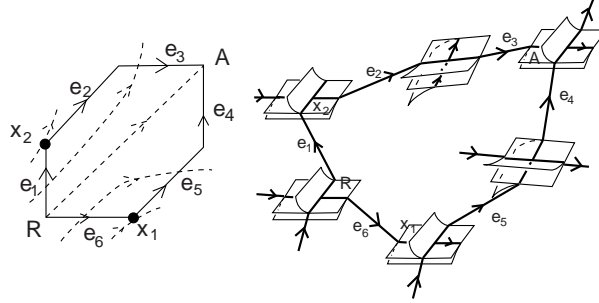

Figure 6: A 2-component of a special dynamic branched surface

The definition of an efficient semi-flow on a special dynamic branched surface, together with lemma 3.5 above and classical arguments about symbolic codings lead to the following lemma:

Lemma 3.6 *Let W be a special dynamic branched surface and let $(\sigma_t)_{t \in \mathbf{R}^+}$ be any efficient semi-flow on W . We call coding train-track τ_W a train-track embedded in W as follows:*

1. *There is one vertex in each open edge of the singular graph \mathcal{S} . There are two vertices in each 2-component D , one on each side of the separating orbit-segment of $(\sigma_t)_{t \in \mathbf{R}^+}$ in D .*
2. *The edges of τ_W are disjointly embedded in the 2-components and do not intersect the separating orbit-segments of the semi-flow. Each of these edges connects a vertex in \mathcal{S} to a vertex in a 2-component. There are exactly three edges incident to each vertex in \mathcal{S} , one in each 2-component of W incident to this point.*
3. *The smoothing at each vertex in \mathcal{S} is the smoothing induced by the smooth structure of the branched surface. The smoothing at a vertex v in a 2-component D is such that the edge connecting v to the locally 1-sheeted side of D is in the locally 1-sheeted side of v .*

Then, for any loop carried by a coding train-track τ_W , there is a periodic orbit of $(\sigma_t)_{t \in \mathbf{R}^+}$ embedded in a regular neighborhood of τ_W in W and which projects along the ties of this neighborhood to the given loop.

See figure 7.

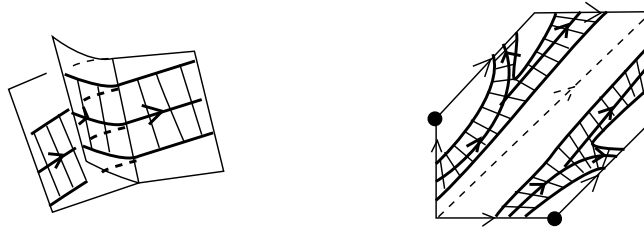

Figure 7: Coding train-track

In proposition 3.7 below, we give an effective criterion to check whether or not a given standard dynamical 2-complex is a special dynamic branched surface.

Proposition 3.7 *A standard dynamical 2-complex K admits a compatible smoothing along its singular graph if and only if the following two properties are satisfied:*

1. *No edge in the boundary of any 2-component connects its repeller to its attractor.*
2. *Each edge e of the singular graph appears exactly once in second position in the union, over all the disc components C , of the ∂ -positive paths of C (see lemma 1.3).*

Proof of proposition 3.7: Let us first prove the sufficiency of the given conditions. Let e be any edge of the singular graph \mathcal{S} . By item (2), there is a ∂ -positive path p of some component C in which e appears in second position. Thus e is consecutive in p to an incoming edge e' at $i(e)$, which occupies the first position in p . From item (2), any edge e appears exactly once in second position in the set of all ∂ -positive paths of disc components. Furthermore, by definition of a dynamical 2-complex, any edge e' appears exactly once in first position in this same set. Thus, one can choose an embedding in \mathbf{R}^2 of a small neighborhood in \mathcal{S} of each crossing which satisfies the following property:

Let e be any edge of the singular graph. Let p be the ∂ -positive path containing e in second position. Let e' be the incoming edge at $i(e)$ which is consecutive to, and precedes e in p . Then, e and e' are adjacent in the cyclic ordering at $i(e)$ induced by the chosen local \mathbf{R}^2 -embedding at this crossing.

There is now a unique way to define a smoothing of the 2-complex in a neighborhood of the crossings which is a compatible smoothing, and such that the tangent plane so defined agrees with the chosen local \mathbf{R}^2 -embedding. The point is to prove that these smoothings can be extended to a compatible smoothing along the singular graph. Let us consider any edge e_{i_1} of $K_{sing}^{(1)}$. There is a disc component C with $l_C = e_{i_1} \cdots e_{i_r} e_{i_{r+1}}^{-1} \cdots e_{i_{r+p}}^{-1}$, $r \geq 1$. Item (1) implies $r > 1$. By definition of l_C , C is on the locally 1-sheeted side of e_{i_1} at $i(e_{i_1})$. For the chosen local \mathbf{R}^2 -embedding, e_{i_1} and e_{i_2} are adjacent in the cyclic ordering at $t(e_{i_1}) = i(e_{i_2})$. Thus, by definition of the smoothing in a neighborhood of the crossings, C does not change side along e_{i_1} , lying on its 1-sheeted side, and therefore no 2-component changes side along e_{i_1} . The same argument can be applied for any edge of $K_{sing}^{(1)}$. Thus, no germ of 2-component changes side along any edge of the singular graph, and we so have a compatible smoothing along the singular graph of the complex.

Let us now prove the reverse implication of proposition 3.7. The necessity of item (1) is straightforward from the definitions. To prove the necessity of item (2), let us assume that K admits a compatible smoothing along its singular graph. This smoothing defines a local \mathbf{R}^2 -embedding at each crossing of the singular graph. Since a smoothing is defined along each edge, each edge e which is in second position in some ∂ -positive path p of a disc component is adjacent, according to the induced cyclic ordering at $i(e) = t(e')$, to the edge e' in first position in p . The conclusion follows. The proof of proposition 3.7 is completed. \diamond

4 Periodic orbits of efficient semi-flows

The aim of this section is to prove proposition 4.1 below. This proposition is the main step to prove one implication of our main result (theorem 5.2), that is if some efficient semi-flow on a special dynamic branched surface admits a cross-section, then there exists what we call a *nice non-negative cocycle* (see definition 5.1).

Proposition 4.1 *Any non flat positive loop in the singular graph of a special dynamic branched surface W is homotopic to a periodic orbit of an efficient semi-flow on W .*

In a first step, we are going to define a class of positive loops in the singular graph which have the property to be homotopic to periodic orbits of any efficient semi-flow. We will then define *elementary homotopies* and show that any non-flat positive loop in the singular graph can be transformed to such a loop by a finite sequence of elementary homotopies. Let us recall that, if p is a path, then $L(p)$ (resp. $F(p)$) denotes the last (resp. first) edge intersected by p . If p' is an oriented subpath of p , with $i(p) = i(p')$ or $t(p) = t(p')$, then $p - p'$ will denote the complementary oriented subpath q of p' in p , i.e. either $p = p'q$ or $p = qp'$.

Definition 4.2 Let l be any positive loop in the singular graph \mathcal{S} of a special dynamic branched surface W . The *flat pieces* of l are the maximal (in the sense of the inclusion) flat subpaths of l , i.e. if c_0, \dots, c_k are the corners of l , the flat pieces of l are the connected components f_0, \dots, f_k of $l \setminus \{c_0, \dots, c_k\}$ with $i(f_j) = c_j = t(f_{j-1})$, $j \in \frac{\mathbf{Z}}{(k+1)\mathbf{Z}}$.

In all what follows, the indices to the flat pieces of a given positive loop l will always be considered written modulo the total number of flat pieces in this loop. Thus, if f_j is any flat piece in l , f_{j+1} (resp. f_{j-1}) is the flat piece following (resp. preceding) f_j in l , and might be equal to f_j if there is only one flat piece in l .

Lemma 4.3 *Any flat path p in the singular graph \mathcal{S} of a special dynamic branched surface W which connects two of the crossings of W admits a unique decomposition $p = p^1 \dots p^k$, $k \geq 1$, such that:*

- For $i < k$, each p^i is a flat 2-side (see lemma 3.5) of some 2-component D^i ,
- The path p^k is contained in a flat 2-side of some 2-component D^k ,
- The integer k is maximum among the decompositions satisfying the preceding properties.

The subpaths p^i (resp. 2-components D^i) above are called the *characteristic subpaths* (resp. *characteristic 2-components*) of p . We call *characteristic ∂ -paths* of p the *∂ -positive paths* q^i of the characteristic 2-components D^i which are in the complement of the p^i in ∂D^i .

See figure 8 or 9.

Proof of lemma 4.3: By definition of a dynamical 2-complex, there are two incoming edges e, e' at the crossing $i(p)$. Exactly one of these two edges, say e' , is such that $e'F(p)$ is a flat path. By remark 1.1, there are exactly two 2-component $D(e, F(p)), D(e', F(p))$ incident to the two turns formed by these incoming edges e, e' with the outgoing edge $F(p)$. By definition of a flat 2-side, if p^1 exists, then it is the flat 2-side h_1 of $D(e, F(p))$ which follows the edge e . Since each edge appears exactly once in first position in the set of ∂ -positive paths, there is no ambiguity. Since p is flat, either p strictly contains h_1 or p is contained in h_1 . In the first case, one takes $p^1 = h_1$. One iterates the process with $p' = p - p^1$. The process is finite and gives us a decomposition of p satisfying the announced properties. The unicity of such a decomposition is easily deduced from the above arguments. \diamond

Remark 4.4 One proves in the course of the proof of lemma 4.3 that the characteristic 2-components D^1, \dots, D^{k-1} are also uniquely defined, where $p = p^1 \cdots p^k$. However, there is a choice for D^k . One will always consider D^k to be the 2-component $D(e, F(p^k))$, where e is, as in the proof of lemma 4.3, the incoming edge at $i(p^k)$ which forms a corner with $F(p^k)$.

Definition 4.5 The *po-length* of a flat path in the singular graph of a special dynamic branched surface is the number of its characteristic subpaths minus 1. The *po-length* of a positive loop l in the singular graph of a special dynamic branched surface is the sum of the po-lengths of its flat pieces.

The following lemma justifies the introduction of these definitions:

Lemma 4.6 Let W be a special dynamic branched surface. Let l be a positive loop in the singular graph of W which contains at least one corner. If the po-length of l is zero, then any efficient semi-flow on W admits a periodic orbit homotopic to l .

Proof of lemma 4.6: Since $po(l) = 0$, $po(f_j) = 0$ for any flat piece f_j of l . By definition of the po-length, and with the notations above, for any j , there exists a segment in the boundary of the characteristic 2-component D_j^1 (this is the unique characteristic 2-component of f_j) connecting $L(f_j)$ to $L(f_{j+1})$. This implies that any coding train-track for W (see lemma 3.6) carries a loop l_τ which decomposes in such segments. Lemma 3.6 gives then, for any efficient semi-flow $(\sigma_t)_{t \in \mathbf{R}^+}$ on W , a periodic orbit of $(\sigma_t)_{t \in \mathbf{R}^+}$ homotopic to l_τ in W . By construction, l_τ is homotopic to l , which completes the proof of lemma 4.6. \diamond

Definition 4.7 Let l be a non flat positive loop in the singular graph of a special dynamic branched surface. Let f_1, \dots, f_r be the flat pieces of l . Let $f_j = f_j^1 \cdots f_j^{k(j)}$ be the decomposition of f_j in characteristic subpaths given by lemma 4.3. An elementary homotopy on l at f_j consists of substituting the characteristic ∂ -path q_j^1 of the characteristic 2-component D_j^1 to the subpath $L(f_{j-1})f_j^1$ of l . An elementary homotopy at f_j is *necessary* if the po-length of f_j is non null.

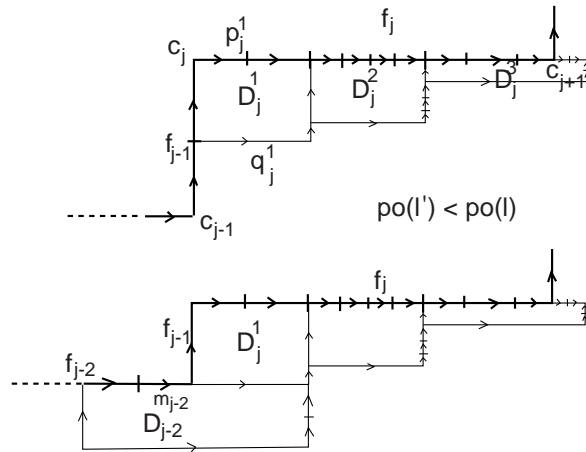

Figure 8: Loops with corners I

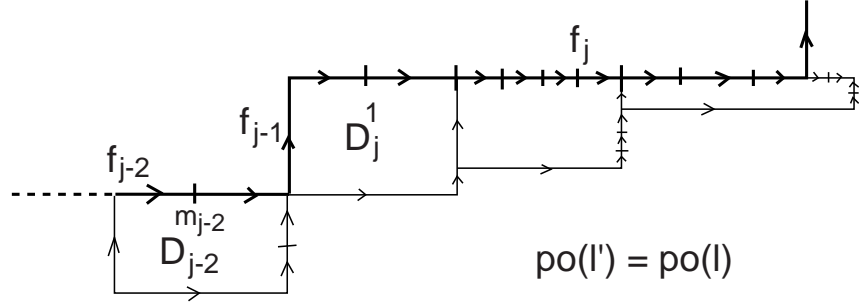

Figure 9: Loops with corners II

Lemma 4.8 *With the assumptions and notations of lemma 4.6,*

1. *If l' is the image of l under some necessary elementary homotopy, then l' is not flat and $po(l') \leq po(l)$.*
2. *Let $f_i, i = 1, \dots, k$ be the flat pieces of l , and let $f_i = f_i^1 \cdots f_i^{k(i)}$ be the decomposition of f_i in characteristic subpaths. We denote by l' the image of l under a necessary elementary homotopy at f_j (which consists of substituting the characteristic ∂ -path q_j^1 to $L(f_{j-1})f_j^1$ - see definition 4.7).*

If $po(l') = po(l)$, then:

- *The flat piece f_{j-1} contains exactly one edge.*
- *There is a natural bijection between the flat pieces f_i of l and the flat pieces f'_i of l' such that $f'_{j-2} = f_{j-2}F(q_j^1)$ and $f_{j-2}^{k(j-2)}$ does not contain $F(q_j^1)$.*

See figures 8 and 9.

Proof of lemma 4.8: Since the elementary homotopy that one applies is necessary, the terminal point of the flat subpath of l that one substitutes is not a corner of l . Therefore, by definition of an elementary homotopy, the new loop l' admits a corner at this point, and thus is not flat.

One applies an elementary homotopy to l at f_j , and one denotes by l' the resulting loop. One distinguishes two cases:

Case I: The flat piece f_{j-1} contains more than one edge.

Case II: The flat piece f_{j-1} contains exactly one edge.

We refer the reader to figures 8 and 9.

Let us first consider the case *I* above, illustrated in the first picture of figure 8. The loop l' admits two flat pieces more than the loop l . They form the path q_j^1 . The first one consists of a single edge, the edge $F(q_j^1)$, where q_j^1 is the characteristic ∂ -path given by lemma 4.3. The second one is then $q_j^1 - F(q_j^1)$. By definition, $po(F(q_j^1)) = 0$ and $po(q_j^1 - F(q_j^1)) = 0$. One has then a natural identification between the flat pieces f_i of l and the flat pieces f'_i of l' in $l' - q_j^1$: Under this identification, the flat piece f'_j is equal to $f_j^2 \cdots f_j^{k(j)}$, where $f_j = f_j^1 \cdots f_j^{k(j)}$ is the decomposition in characteristic subpaths given by lemma 4.3. Thus, $po(f'_j) = po(f_j) - 1$. The flat piece f'_{j-1} is equal to $f_{j-1} - L(f_{j-1})$. Beware that with the

numerotation we use for the flat pieces of l' , there are the two additional flat pieces given above between f'_{j-1} and f'_j . Since f_{j-1} contains more than one edge, $po(f'_{j-1}) \leq po(f_{j-1})$. The other flat pieces of l are not modified when passing from l to l' , and thus, if $i \neq j$ and $i \neq j-1$, then $po(f'_i) = po(f_i)$. Therefore, in this case, $po(l') < po(l)$.

Let us now consider case *II* (see figure 9). This figure illustrates the natural identification between the flat pieces f_i of l and the flat pieces f'_i of l' . As in case *I*, $po(f'_j) = po(f_j) - 1$. The piece f'_{j-1} is equal to $q_j^1 - F(q_j^1)$. Thus $po(f'_{j-1}) = 0$. If i is distinct from $j, j-1, j-2$, as in case *I*, $f'_i = f_i$, hence $po(f'_i) = po(f_i)$. It remains to compute $po(f'_{j-2})$. By definition of an elementary homotopy, $f'_{j-2} = f_{j-2}F(q_j^1)$. Therefore, by definition of the po-length, if $p_{j-2}^{k(j-2)}$ contains $F(q_j^1)$, then $po(f'_{j-2}) = po(f_{j-2})$. Thus, in this case, $po(l') = po(l) - 1$. In the other case, $po(f'_{j-2}) = po(f_{j-2}) + 1$, and thus $po(l') = po(l)$. This completes the proof of lemma 4.8. \diamond

One can now complete the proof of proposition 4.1. One assumes given some efficient semi-flow $(\sigma_t)_{t \in \mathbf{R}^+}$ on a special dynamic branched surface W . By lemma 4.6, any non-flat positive loop l in the singular graph \mathcal{S} of W with $po(l) = 0$ is homotopic to a periodic orbit of $(\sigma_t)_{t \in \mathbf{R}^+}$. Let us now consider a non-flat positive loop l in \mathcal{S} with $po(l) \neq 0$. One applies a necessary elementary homotopy to l , say at the flat piece f_{j+2} . One denotes by l_1 the resulting loop. By lemma 4.8, $po(l_1) \leq po(l)$. If $po(l_1) = po(l)$ then by lemma 4.8, item (2) one has a bijection between the flat pieces of l and the flat pieces of l_1 . Under this bijection the flat piece f_j of l has as image the flat piece \mathbf{f}_j of l_1 , equal to $f_j e^1$ for some edge e^1 . The edge e^1 satisfies that, if one applies all the necessary elementary homotopies along \mathbf{f}_j , one eventually gets a flat piece reduced to this single edge. In particular, the po-length of \mathbf{f}_j is non-zero. One applies an elementary homotopy on l_1 at \mathbf{f}_j . One iterates the process. Then:

- Either at some step one obtains a loop l_i with $po(l_i) < po(l_{i-1})$.
- Or the number of flat pieces remains constant by lemma 4.8. Thus one eventually applies an elementary homotopy at the flat piece \mathbf{f}_{j+2} of a new loop l_{k_1} . If this elementary homotopy does not make decrease the po-length of l_{k_1} , then, as at the first step, the flat piece \mathbf{f}_j of the new loop is the concatenation of $f_j e^1$ with a single edge e^{k_1+1} . Furthermore, always by the same observation than at the first step, the edge e^1 is the flat 2-side of some 2-component. By iteration of this process, if the po-length never decreases, then the finiteness of the singular graph implies the existence of a circuit $C = e^1 e^{k_1+1} \dots e^{k_m+1}$ such that each edge in this circuit is the flat 2-side of some 2-component (see figure 10).

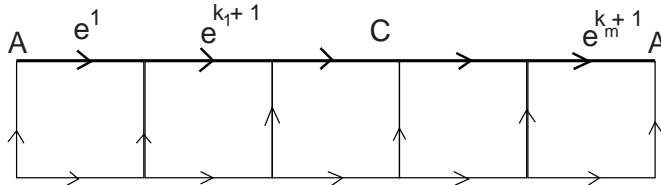

Figure 10: An impossible circuit

By definition of a special polyhedron, the circuits of W are trivalent. Since a smoothing is defined along the circuits, one so gets the existence of a 2-component in the

locally 2-sheeted side of C which admits C as boundary loop. Since a special dynamic branched surface admits only disc components and is a dynamical 2-complex, this is impossible.

One so obtains a sequence of elementary homotopies which always terminates with a non-flat positive loop l_n , homotopic to l in W and such that $po(l_n) = 0$. Together with lemma 4.6, this completes the proof of proposition 4.1. \diamond

5 Searching cross-sections

Definition 5.1 A *nice non-negative cocycle* of a special dynamic branched surface W is a non-negative cocycle $u \in C^1(W; \mathbf{Z})$ such that the union of all the positive loops l in the singular graph for which $u(l) = 0$ holds is a union of disjointly embedded circuits of W .

This section is devoted to a proof of the following theorem.

Theorem 5.2 *Some, and hence any, efficient semi-flow on a special dynamic branched surface W admits a cross-section if and only if there exists a nice non-negative cocycle $u \in C^1(K; \mathbf{Z})$. Any such cocycle defines a cross-section to any efficient semi-flow on W .*

Remark 5.3 Theorem 7.3 sharpens theorem 5.2 above in the case where the special dynamic branched surface is the spine of some compact 3-manifold. However, one can construct special dynamic branched surfaces admitting nice non-negative cocycles which are not *positive* one (see definition 7.2). This forbids to hope to obtain a better criterion in the general case of special dynamic branched surfaces.

5.1 From a nice non-negative cocycle to a cross-section

The following lemma is a straightforward corollary of lemma 3.5 and of the definition of efficient semi-flow in lemma 3.3 (see figure 6).

Lemma 5.4 *Any properly embedded orbit-segment of any efficient semi-flow on a special dynamic branched surface is homotopic, relative to its endpoints if any, to a positive path in the singular graph whose number of corners is equal to the number of 2-components intersected by this orbit-segment (there is at least one).*

Let us assume the existence of some nice non-negative cocycle $u \in C^1(W; \mathbf{Z})$, where W is any special dynamic branched surface. By proposition 1.24, this cocycle defines, for any efficient semi-flow $(\sigma_t)_{t \in \mathbf{R}^+}$ on W , a \mathbf{r} -embedded graph Γ_u transverse to $(\sigma_t)_{t \in \mathbf{R}^+}$. Since u is a nice non-negative cocycle, the intersection-number of this graph Γ_u with any positive loop containing at least one corner is strictly positive. By finiteness of the singular graph, lemma 5.4 implies then that any orbit of $(\sigma_t)_{t \in \mathbf{R}^+}$ will intersect Γ_u transversely and positively in finite time. The above \mathbf{r} -embedded graph Γ_u is then a cross-section to $(\sigma_t)_{t \in \mathbf{R}^+}$. One so proved the last point of theorem 5.2, and one implication of this theorem.

5.2 From cross-sections to nice non-negative cocycles

By definition of a cross-section, proposition 4.1 implies that any integer cocycle u defined by a cross-section to an efficient semi-flow on a special dynamic branched surface W is positive on any non-flat positive loop of the singular graph \mathcal{S} . Let us consider the flat loops, that is the embedded circuits. If u is negative on some embedded circuit C , then u is negative on some positive loop $C^k p$, where p is some positive path in \mathcal{S} between two crossings of W , which does not intersect C in its interior, and k is an integer greater than $|\frac{u(p)}{u(C)}|$. The existence of p comes from the fact that any two crossings in \mathcal{S} are connected by a positive path. The loop $C^k p$ has at least one corner, at $i(p)$ or $t(p)$, and u is negative on $C^k p$. Proposition 4.1 implies then a contradiction with u representing a cross-section. Therefore, u is non-negative on the embedded circuits of \mathcal{S} . One so proved that the cohomology class defined by the cross-section is a non-negative cohomology class. Corollary 1.17 implies then that it is represented by a non-negative cocycle, and, from which precedes, this non-negative cocycle has to be a nice non-negative cocycle. This completes the proof of the missing implication of theorem 5.2.

6 Efficient semi-flows are dilating

In this section, we are interested in the dynamical behaviour of the efficient semi-flows of a special dynamic branched surface. Our result is proposition 6.4 below. This proposition is an intermediate step to prove proposition 7.1 further in the paper, and to eventually obtain a criterion of existence of cross-sections in certain hyperbolic attractors (theorem 7.3).

Definition 6.1 Let W be a special dynamic branched surface.

A path p in W is *carried* by W if it is transverse to the singular graph \mathcal{S} of W and, at each intersection-point x in $p \cap \mathcal{S}$, crosses both the locally 2-sheeted side and the locally 1-sheeted side of x .

A path p in W is *properly embedded* if it is an embedded path which does not contain any crossing of W and such that:

- Its endpoints belong to some separating orbit-segment of W .
- For each 2-component C of W , each connected component of $p \cap C$ intersects exactly once the separating orbit-segment of C .

The *combinatorial length* $l(p)$ of a properly embedded path p is equal to the number of intersection-points of p with the union of the separating orbits of W minus 1.

Remark 6.2 When speaking of the “number of intersection-points of a path p with the union of the separating orbits”, we mean the number of points in the image of p which also belong to some separating orbit. The combinatorial length of a properly embedded path p is also equivalently defined as the number of intersection-points of the interior of the path with the union of the separating orbits, plus 1, or also the number of 2-components crossed by the path, plus 1.

Definition 6.3 Let W be a special dynamic branched surface. Let $(\sigma_t)_{t \in \mathbf{R}^+}$ be some efficient semi-flow on W .

If p is a properly embedded path carried by W , then p is *dilated* by $(\sigma_t)_{t \in \mathbf{R}^+}$ if there is $\lambda > 1$, $C > 0$ and $t_0 > 0$ such that $l(\sigma_{nt_0}(p)) \geq C\lambda^n l(p)$ for any integer $n \geq 1$.

Proposition 6.4 *Let W be a special dynamic branched surface. Let $(\sigma_t)_{t \in \mathbf{R}^+}$ be some efficient semi-flow on W .*

There exists $M > 0$ such that, if p is any properly embedded path carried by W , of combinatorial length greater or equal to M , then p is dilated by $(\sigma_t)_{t \in \mathbf{R}^+}$.

Let us first notice that the hypothesis for p to be carried by W is necessary in order to have $\sigma_t(p)$ a path in W for any time $t \geq 0$. Indeed, one required that a path is a *locally injective* map from the interval to W . By definition of an efficient semi-flow, this is not the case for $\sigma_t(p)$, t any positive real, if p is not carried by W .

Lemma 6.5 *With the assumptions and notations of proposition 6.4, let $C(p)$ be the set of points $x \in p$ such that there exists $t_x > 0$ satisfying that $\sigma_{t_x}(x)$ is a crossing of W , for all $t' < t_x$, $\sigma_{t'}(x)$ is distinct from the crossings and $\sigma_{t'}(x)$ does not belong to p . Then the cardinality $N(p)$ of $C(p)$ is finite. If $N(p)$ is strictly greater than the combinatorial length of p , then $l(\sigma_{t_1}(p)) \geq l(p) + 1$ for some $t_1 > 0$.*

Proof of lemma 6.5: Since W is compact, the number of crossings is finite. By definition, $N(p)$ is lesser or equal to the number of crossings, and thus is finite. Assume now that $N(p)$ is strictly greater than the combinatorial length of p . This implies that there exists at least one point $x \in p$ which is not in a separating orbit, but whose image after t_x belongs to a separating orbit. Furthermore, if some point x belongs to a separating orbit, then this remains true for any $\sigma_t(x)$, $t \geq 0$. Figure 11 illustrates the phenomenon of dilatation, or non-dilatation when homotoping p along the semi-flow through a crossing. In this figure, α denotes the possible intersections of p with the neighborhood of a crossing, it is important here to recall that p is carried by W . Let t_{max} be the supremum of all the times t_x for $x \in C(p)$. Since $N(p)$ is finite, t_{max} is finite. From which precedes, the combinatorial length of $\sigma_{t_{max}+\epsilon}(p)$, $\epsilon > 0$ small, which consists of counting the number of intersection-points of the interior of the path with the union of the separating orbits, is equal to $N(p) \geq l(p) + 1$. This completes the proof of the lemma. \diamond

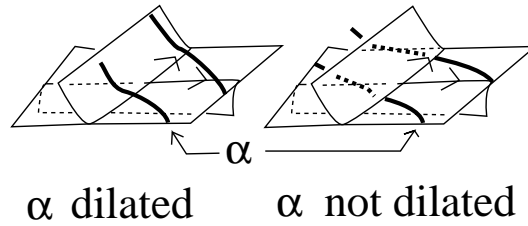

Figure 11: Local dilatation of a properly embedded carried path

Lemma 6.6 *With the assumptions and notations of proposition 6.4, There exists $t'_2 > 0$ such that any properly embedded loop p carried by W satisfies $l(\sigma_{t_2}(p)) \geq l(p) + 1$.*

Proof of lemma 6.6: Let p be any properly embedded loop carried by W . Let C be any circuit of W intersected by p (there exists at least one). By compactity of W , there exists $t'_2 > 0$ such that any crossing of C is in the image of some σ_t , $t < t'_2$. If for some $t \leq t'_2$, $N(\sigma_t(p)) > l(p)$, then $l(\sigma_{t'_2}(p)) \geq l(p) + 1$ by lemma 6.5. Let us assume $N(\sigma_{t'_2}(p)) = l(p)$. Then, for any $t < t'_2$, any connected component of the intersection of $\sigma_t(p)$ with a small

neighborhood of any crossing v in C is an arc which intersects in this neighborhood the separating orbit of v . In other words, the intersection of $\sigma_t(p)$ with a neighborhood of a crossing in C is in the case of no dilatation illustrated by figure 11. This implies that none of the two phenomena illustrated by figure 12 occurs along any edge in C . That is: Let v be any crossing in C . Let w be the crossing following v in C , and let $[vw]$ an edge in C connecting v to w . If some germ of 2-component at v contains two germs of edges at v which are consecutive in C , then the germ at w to which it is connected through $[vw]$ satisfies this same property. Therefore, there exists a 2-component which is on the locally 2-sheeted side of any point of C , and which contains C in its boundary, that is admits C as boundary circle. By definition of a special dynamic branched surface, the 2-components are discs. And a special dynamic branched surface is in particular a dynamical 2-complex. One so obtains a contradiction with the definition of dynamical 2-complex, which states in particular that, in the boundary of a disc component, there are exactly one repeller and one attractor for the orientation induced by the edges of the singular graph. The proof of lemma 6.6 is completed. \diamond

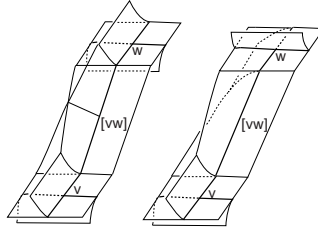

Figure 12: Never occurs if no dilatation

Corollary 6.7 *With the assumptions and notations of proposition 6.4, there exist $M > 1$ and $t_2 > 0$ such that, if p is any properly embedded path carried by W of combinatorial length $l(p) \geq jM$, $j \geq 1$, then $l(\sigma_{t_2}(p)) \geq l(p) + j$.*

Proof of corollary 6.7: Since the singular graph \mathcal{S} of W is finite, there exists $M > 1$ such that if $l(p) \geq M$, then some edge of \mathcal{S} will contain two points of p . This implies that one can embed a loop b in a small neighborhood of a subpath p' of p in W , which intersects the same edges of the singular graph than p' . One proved in lemma 6.6 that there exists $t'_2 > 0$ such that $l(\sigma_{t'_2}(b)) \geq l(b) + 1$. The arguments used precedingly clearly apply to show that p' satisfies this same property, i.e. there exists $t_2 > 0$, which will be fine for any path p' as above, such that $l(\sigma_{t_2}(p')) \geq l(p') + 1$ (t_2 is possibly slightly greater than t'_2). Therefore, $l(\sigma_{t_2}(p)) \geq l(p) + 1$. If $l(p) \geq jM$, then p contains at least j distinct subpaths as the subpath p' above. Therefore, in this case $l(\sigma_{t_2}(p)) \geq l(p) + j$. This completes the proof of corollary 6.7. \diamond

Proof of proposition 6.4: By corollary 6.7, there exist $t_2 > 0$ and $M > 1$ such that, if p is any properly embedded path carried by W with $l(p) = jM + r$, $r \leq M - 1$, then $l(\sigma_{t_2}(p)) \geq l(p) + j$. That is $l(\sigma_{t_2}(p)) \geq l(p)(1 + \frac{1}{M}) - \frac{r}{M}$. Let us observe that $-\frac{r}{M} \geq \frac{1}{M} - 1$. Let $\lambda' = 1 + \frac{1}{M}$ and $C' = \frac{1}{M} - 1$ (C' is negative). From which precedes, by definition of a semi-flow, $l(\sigma_{nt_2}(p)) \geq l(p)(\lambda'^n + \frac{C'}{l(p)}(\lambda'^{n-1} + \lambda'^{n-2} + \dots + 1))$. Since $l(p) \geq M$ and $C' < 0$, $l(\sigma_{nt_2}(p)) \geq l(p)(\lambda'^n + \frac{C'}{M}(\lambda'^{n-1} + \lambda'^{n-2} + \dots + 1))$. Since $\lambda'^{n-1} + \lambda'^{n-2} + \dots + 1 = \frac{1 - \lambda'^n}{1 - \lambda'}$, $\lambda'^n + \frac{C'}{M}(\lambda'^{n-1} + \lambda'^{n-2} + \dots + 1) = \lambda'^n(1 - \frac{C'}{M(1 - \lambda')}) + \frac{C'}{M(1 - \lambda')}$. By definition, $\frac{C'}{M(1 - \lambda')} = 1 - \frac{1}{M}$.

Thus $\frac{C'}{M(1-\lambda')} > 0$ and $1 - \frac{C'}{M(1-\lambda')} > 0$. This implies $l(\sigma_{nt_2}(p)) \geq (1 - \frac{C'}{M(1-\lambda')})\lambda'^n l(p)$ for any properly embedded path p carried by W with $l(p) \geq M$, where $\lambda' > 1$ by definition. This completes the proof of proposition 6.4. \diamond

7 Hyperbolic flows

We show below that, when one is given a special dynamic branched surface W , which is a spine of some 3-manifold M_W , then an efficient semi-flow on W will define a *hyperbolic flow* on M_W . We refer the reader to [17], [5, 3] or [13, 14, 15] among many others for basic definitions of hyperbolic dynamic.

We show in this section how our criterion of existence of cross-sections on special dynamic branched surfaces gives a criterion of existence of cross-sections to the hyperbolic attractors associated to these branched surfaces (theorem 7.3).

Proposition 7.1 *Let W be a special dynamic branched surface which is the spine of some 3-manifold M_W . Then any efficient semi-flow on W is semi-conjugated to some hyperbolic flow on M_W .*

This proposition relies mainly on “classical” stuff, essentially found in the work of Christy. The difference with the usual setting is the following one: Whereas, usually, branched surfaces appear as the quotient of hyperbolic attractors, here one is given a particular kind of branched surface and one wants to prove that they allow to reconstruct such attractors. This is why we need proposition 6.4 at the end of the proof of proposition 7.1.

Proof of proposition 7.1: By definition of a special dynamic branched surface, a differentiable structure is defined at each point of the 2-complex. One can always choose an embedding $i_W: W \rightarrow M_W$ which preserves this differentiable structure, and such that there is a retraction $r_W: M_W \rightarrow i_W(W)$ as given by definition 2.1. Let us observe that, once chosen a maximal atlas (ϕ_i, U_i) for M_W , one obtains a collection of local embeddings $p_i = \phi_i \circ i_W$ in \mathbf{R}^3 of overlapping open sets $V_i = i_W^{-1}(U_i \cap i_W(W))$ which cover W . This defines a cyclic ordering on the germs of 2-cells at each point $x \in W$. If C is any circuit of W , its lift under r_W^{-1} in the boundary of M_W contains an embedded closed curve. It is formed by the extremities of the arms of the triods $r_W^{-1}(x)$, $x \in C$, which lie between, according to the above cyclic ordering, the two germs of 2-cells which are on the locally 2-sheeted side of x . One collapses each such arm to its extremity in ∂M_W , so that the above embedded closed curve becomes a set of tangency points of the fibers of a new retraction, denoted by r_W^s , of M_W onto W . By construction, all the fibers $r_W^s{}^{-1}(x)$, $x \in W$, are intervals which are transverse at their endpoints to ∂M_W , and which admit exactly one interior point of tangency with ∂M_W if x is in the singular graph of W , but is not a crossing of W , and exactly two such points of tangency if x is a crossing of W .

As in proposition 2.3, once chosen an efficient semi-flow $(\sigma_t)_{t \in \mathbf{R}^+}$ on W , the retraction r_W^s defined above allows to construct a non-singular flow $(\phi_t)_{t \in \mathbf{R}^+}$ which is semi-conjugated to $(\sigma_t)_{t \in \mathbf{R}^+}$ by r_W^s . In order to prove that $(\phi_t)_{t \in \mathbf{R}^+}$ can be chosen to be a hyperbolic flow, one has to show that one can define, at each point of the interior of M_W , three independent directions, one tangent to $(\phi_t)_{t \in \mathbf{R}^+}$, and the two others such that the flow is contracting along one and dilating along the other.

One easily defines a combinatorial metric on the fibers of the retraction r_W^s such that the flow $(\phi_t)_{t \in \mathbf{R}^+}$ will be contracting along these fibers. It suffices to assign to each fiber a

length of 1. Since by construction $(\phi_t)_{t \in \mathbf{R}^+}$ flows from the locally 2-sheeted side to the locally 1-sheeted side in a lift under $r_W^s^{-1}$ of a neighborhood in W of the singular graph, the image of two fibers, each of length 1, is contained in a fiber, also of length 1. The conclusion is straightforward.

Let us now observe that one can choose $(\phi_t)_{t \in \mathbf{R}^+}$ to leave invariant a codim 1-foliation \mathcal{F}_u transverse to the fibers of the retraction r_W^s . Indeed, one has a natural horizontal foliation $P_{C_i} \times [-1, 1]$ of each polygonal box $r_W^s^{-1}(C_i)$, where P_{C_i} is a polygon and C_i is any 2-component of W identified with $P_{C_i} \times \{0\}$. The glueing of these polygonal boxes to obtain M_W induces a glueing between the horizontal leaves $P_{C_i} \times \{t\}$ of these boxes, which defines a codim 1-foliation \mathcal{F}_u of M_W transverse to the fibers of r_W^s . A small pertubation in a neighborhood of ∂M_W allows to make this foliation transverse to the boundary of the manifold. One easily shows that the flow $(\phi_t)_{t \in \mathbf{R}^+}$ can be chosen to leave invariant this foliation (beware however that this is no more true for the general class of dynamical 2-complexes).

One defined in section 6 a combinatorial length on the paths properly embedded in W (see definition 6.1). One then proved that any such path carried by W which is sufficiently long is dilated by any efficient semi-flow (see proposition 6.4). One easily checks that the paths carried by W are exactly the paths which lift under $r_W^s^{-1}$ to paths embedded in some leaf of \mathcal{F}_u . Moreover, the cell-decomposition of W lifts under $r_W^s^{-1}$ to a cell decomposition of the leaves of \mathcal{F}_u . One so obtains a combinatorial metric on these leaves such that any path in a leaf of combinatorial length greater than some constant $M > 1$ and which projects under r_W^s to a properly embedded path is dilated by the flow induced by $(\phi_t)_{t \in \mathbf{R}^+}$ on the leaf. This gives us a third direction at each point of $M_W - \partial M_W$ along which $(\phi_t)_{t \in \mathbf{R}^+}$ is dilating for the chosen metric.

From which precedes, one constructs a metric on M_W such that $(\phi_t)_{t \in \mathbf{R}^+}$ is as announced. This completes the proof of proposition 7.1. \diamond

Definition 7.2 A *positive cocycle* of a flat dynamical 2-complex is a non-negative cocycle which is positive on all the embedded positive loops of the singular graph.

Theorem 7.3 *Let W be a special dynamic branched surface which is the spine of some 3-manifold M_W . If $(\phi_t)_{t \in \mathbf{R}^+}$ denotes any hyperbolic flow as given by proposition 7.1, then the flow $(\phi_t)_{t \in \mathbf{R}^+}$ admits a cross-section if and only if there exists a positive cocycle $u \in C^1(W; \mathbf{Z})$. Any such cocycle defines a cross-section to $(\phi_t)_{t \in \mathbf{R}^+}$.*

Proof of theorem 7.3: Any cross-section to $(\phi_t)_{t \in \mathbf{R}^+}$ defines a cohomology-class in $H^1(M_W; \mathbf{Z})$, and thus of $H^1(W; \mathbf{Z})$. By definition, for any periodic orbit O of the efficient semi-flow on W semi-conjugated by r_W^s to $(\phi_t)_{t \in \mathbf{R}^+}$, there is a periodic orbit O' of $(\phi_t)_{t \in \mathbf{R}^+}$ with $r_W^s(O') = O$. In particular, O' is homotopic to O . From proposition 4.1 and corollary 1.17, any cross-section to $(\phi_t)_{t \in \mathbf{R}^+}$ then defines a nice non-negative cocycle of $C^1(W; \mathbf{Z})$. The following lemma implies that it defines in fact a positive cocycle:

Lemma 7.4 *Any nice non-negative cocycle of a special dynamic branched surface W which is the spine of some 3-manifold M_W is a positive cocycle.*

Proof of lemma 7.4: If not, then we prove in [10] that u defines a transversely oriented foliation of the branched surface in compact graphs all homotopically equivalent. Except for a finite number, the graphs which are the leaves of this foliation are transverse to the singular graph \mathcal{S} of W . If there are N circuits C_1, \dots, C_N of W with $u(C_i) = 0$, then each

of these circuits C_i is contained in a graph Γ_i of the foliation, which is otherwise transverse to $\mathcal{S} - C_i$. In the case where W is the spine of a 3-manifold M_W , this foliation in compact graphs lifts, under the retraction r_W^s , to a transversely oriented foliation of M_W in compact surfaces such that a finite number of leaves $S_1 = r_W^s(\Gamma_1), \dots, S_N = r_W^s(\Gamma_N)$ have a circle of tangencies T_i with the boundary. These are the circles in the lift under r_W^s of the circuits C_i which are the sets of points of tangency of the fibers of the retraction r_W^s with ∂M_W (see proof of proposition 7.1). On both sides of a surface S_i , in an ϵ -neighborhood, $\epsilon > 0$ small, there are two properly embedded surfaces S_i^-, S_i^+ with the same Euler characteristic than S_i and such that S_i^- intersects the locally 2-sheeted side of C_i whereas S_i^+ intersects its locally 1-sheeted side (we consider the branched surface embedded in the manifold). In the ϵ -neighborhood in ∂M_W of the circle $T_i \in S_i \cap \partial M_W$, there are one or two boundary-loops of the surface S_i^- . The other boundary-loops of S_i^- are in bijection with the boundary loops of S_i . For all the preceding observations, we refer the reader to figure 13.

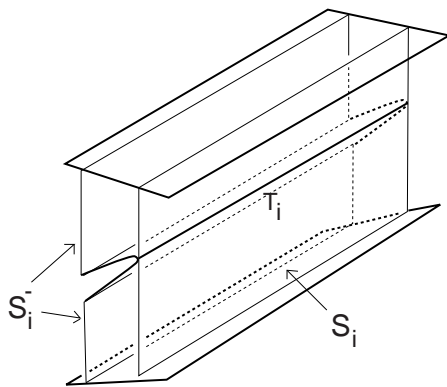

Figure 13: Change of homeomorphism-type when passing through a circuit

Moreover, the surfaces S_i and S_i^+ clearly have the same number of boundary-components. This implies that this number decreases when passing from S_i^- to S_i^+ . But the existence of the foliation implies that one eventually returns to the same surface S_i^- . Which cannot happen because, each time that one passes by some S_j , the number of boundary-components decreases and one easily checks that it never increases. One so obtains a contradiction and proves that there are no circuit of W in the kernel of u , i.e. u is a positive cocycle. \diamond

Since a positive cocycle is in particular a nice non-negative cocycle, the reverse implication, and the end, of theorem 7.3 comes from theorem 5.2 and proposition 2.6. \diamond

Remark 7.5 The fact that a nice non-negative cocycle which defines a cross-section to $(\phi_t)_{t \in \mathbf{R}^+}$ is a positive cocycle can be deduced, as we say in the introduction, from the work of Christy who shows that the circuits lift to periodic orbits of the hyperbolic attractor.

Example: A hyperbolic attractor without any cross-section collapsing to a special dynamic branched surface

Before looking at this example, let us observe that Christy, in [3], gives many examples of hyperbolic attractors with or without cross-sections. However, those without section are

more complicated in the sense that they have annular 2-components.

In figures 14 and 15, we give the singular graph \mathcal{S} and the disc components of a special dynamic branched surface W .

Using the embeddability criterion of [1] for instance (see also [4]), one checks that W is the spine of an orientable compact 3-manifold M_W . Let us recall how to do this. One chooses an embedding in \mathbf{R}^3 of a neighborhood of each crossing. Each such local embedding defines a cyclic ordering on the germs of 2-components around the germs of edges of \mathcal{S} at the corresponding crossing. Therefore, for each edge e of \mathcal{S} , one so defined a cyclic ordering on the germs of 2-cells at e , both in a neighborhood of the initial crossing $i(e)$ and of the terminal crossing $t(e)$. Since there are only three germs of 2-components incident to each edge, these two cyclic orderings either agree or disagree. This allows to assign to each edge a weight of 0, in the case they agree, or +1, in the case they disagree. From [1], W is the spine of some compact 3-manifold M_W , unique up to homeomorphism, if and only if the sum of these weights along the boundary loop of each disc component is even. The manifold M_W is then orientable if and only if the sum of the weights along each loop of the singular graph is even. Local embeddings in \mathbf{R}^3 of a neighborhood of each crossing of W are shown in figure 14. For these choices, all the weights are null.

From proposition 7.1, for any efficient semi-flow $(\sigma_t)_{t \in \mathbf{R}^+}$ on W , one gets a hyperbolic flow on M_W . From theorem 7.3, this hyperbolic flow admits a cross-section S_u if and only if there exists a nice non-negative cocycle $u \in C^1(W; \mathbf{Z})$. Searching for the non-negative integer cocycles amounts to search for the non-negative integer solutions of the linear system with integer coefficients $M_{\delta_W^1} X = 0$, where

$$M_{\delta_W^1} = \begin{pmatrix} 1 & 0 & 0 & 0 & 1 & -1 & -1 & -1 & -2 & 0 & 0 & 0 \\ -1 & 1 & 0 & 1 & -1 & 0 & 0 & 0 & 0 & -1 & -1 & -1 \\ 0 & 0 & 0 & 0 & 0 & -1 & 1 & 0 & 0 & 1 & -1 & 0 \\ 0 & 1 & -2 & 1 & 0 & 0 & 0 & 0 & 0 & 0 & 0 & 0 \\ 0 & 0 & 0 & 0 & 0 & 0 & -1 & 1 & 0 & 0 & 1 & -1 \\ -1 & -1 & -1 & -1 & -1 & -1 & 0 & -1 & 1 & 1 & 0 & 1 \end{pmatrix}$$

is the matrix of the first co-boundary operator. The j^{th} coefficient of the i^{th} is the signed number of times the edge e_j of the singular graph \mathcal{S} appears in the boundary of the i^{th} disc component (numbered from left to right and from top to bottom when looking at figure 15). The coordinate x_j of a vector-solution $X = (x_0, x_1, \dots, x_{11})$, if any, gives the value of the corresponding cocycle on the edge e_j . This is the algebraic intersection-number with the edge e_j of the r -embedded graph $\Gamma_u = r_W(S_u)$, which is a cross-section to the semi-flow $(\sigma_t)_{t \in \mathbf{R}^+}$ semi-conjugated by r_W to the chosen hyperbolic flow. Equivalently, this is the number of vertices of Γ_u along e_j .

Using the program Mapple, one checks that there are no non-negative solutions to the system $M_{\delta_W^1} X = 0$. Thus, there are no non-negative cocycles, and so no cross-sections to any of the hyperbolic flows constructed from M_W .

A presentation of the fundamental group of M_W is obtained by choosing a maximal tree in the singular graph \mathcal{S} , the edges in its complement being then in bijection with the generators of $\pi_1(M_W)$. We give below such a presentation, the chosen maximal tree being the one formed by the edges e_0, e_1, e_4, e_5, e_6 :

$$\pi_1(M_W) = \langle e_2, e_3, e_7, e_8, e_9, e_{10}, e_{11}; w_1 = 1, w_2 = 1, w_3 = 1, w_4 = 1, w_5 = 1, w_6 = 1 \rangle$$

where $w_1 = e_8 e_7 e_8$, $w_2 = e_3^{-1} e_9 e_{10} e_{11}$, $w_3 = e_9^{-1} e_{10}$, $w_4 = e_3^{-1} e_2^2$, $w_5 = e_{11}^{-1} e_{10} e_7$, $w_6 = e_3^{-1} e_2^{-1} e_7^{-1} e_{11} e_8 e_9$.

Let us finally observe that M_W has only one boundary-component. This is noticed by checking that W has only one circuit, that each boundary-component contains at least one curve which projects to a circuit and that there is exactly one such curve in the lift of each circuit. Let us recall that, in the orientable case, all the boundary-components are tori.

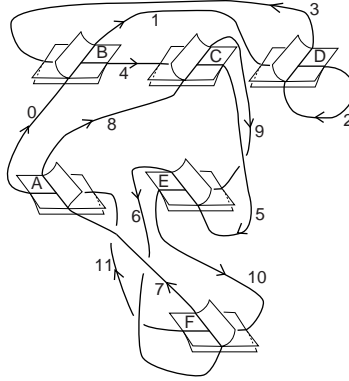

Figure 14: The singular graph of an embedded special dynamic branched surface without any non-negative cocycle

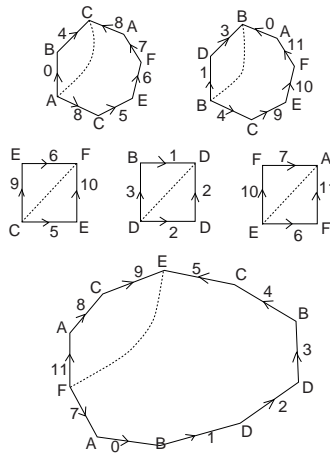

Figure 15: The 2-components of the above branched surface

8 Appendix: Boundary-tangent flows

We show in this Appendix how to construct boundary-tangent flows from semi-flows on dynamical 2-spines of 3-manifolds. We then give a necessary and sufficient criterion of existence of cross-sections to these flows.

Let K be a flat dynamical 2-spine of some 3-manifold M_K . There is a covering of K by a finite union of overlapping open neighborhoods $N(x_i)$, $i = 1, \dots, k$, such that each $N(x_i)$ lifts, under $r_{M_K}^{-1}$, to four disjoint discs D_i^j in ∂M_K if x_i is a crossing of K , to three disjoint discs D_i^j if x_i is a singular point distinct from a crossing and to two disjoint discs D_i^j if

x_i is a non-singular point of K . The collection of all these discs D_i^j cover ∂M_K . Each D_i^j projects, under r_{M_K} , to a disc in K , and any combinatorial semi-flow on K restricts to a singular flow on such a disc $r_{M_K}(D_i^j)$ (see figure 16). This leads to the following lemma:

Lemma 8.1 *Let K be a flat dynamical 2-spine of some 3-manifold M_K . Any combinatorial semi-flow on K lifts, under $r_{M_K}^{-1}$, to a singular flow on ∂M_K .*

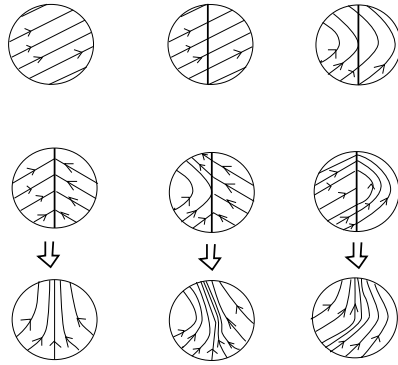

Figure 16: Desingularizing a boundary-flow

Figure 16 illustrates the different possible models of disc $r_{M_K}(D_i^j)$. The first disc represents a neighborhood of a non singular point, and the semi-flow restricts to a non singular flow on this disc with two points of tangency with the boundary. The other discs are overlapping discs in the neighborhood of a point interior to an edge e of the singular graph. The thick line in the figure represents the interval which is a neighborhood in e of the point considered. In the last two discs of the first line, the semi-flow restricts to a non singular flow. In a neighborhood of a singular point interior to an edge of the singular graph, there always is exactly one such disc. In the discs of the second line, the semi-flow gives rise to a singular flow, whose singularities are along a segment contained in the interval coming from the edge of the singular graph. The singularities of the flow on ∂M_K given by lemma 8.1 belong to a trivalent graph Γ in ∂M_K , formed by the union of the extremities of the triods and 4-ods pre-images under $r_{M_K}^{-1}$ of the singular points in K . These singularities form a union of possibly disjoint intervals contained in this graph Γ .

From a singular flow on ∂M_K as given by lemma 8.1, one gets a non-singular flow on ∂M_K by desingularizing as indicated by figure 16. One blows up an interval I in the above graph Γ to a rectangle $I \times [-1, 1]$, with I identified to $I \times \{0\}$. The singular flow defined above from the semi-flow on K is then modified as illustrated in the last line of figure 16. The intervals of singularities become orbits segments for the non-singular flow defined, which are locally attracting. A non-singular flow on ∂M_K obtained in this way from the singular flow given by lemma 8.1 will be called below a ∂ -flow.

Remark 8.2 In the case of a special dynamic branched surface W , the graph Γ in ∂M_W formed by the union of the endpoints of the fibers of the retraction r_W contains a union of disjointly embedded loops, exactly one for each circuit of W , which project to these circuits under r_W . They are the set of points of tangency with ∂M_W of the fibers of the retraction r_W^s defined in the proof of proposition 7.1. By definition of a ∂ -flow, they are periodic orbits of such a flow on ∂M_W .

Let K be a flat dynamical 2-spine of a 3-manifold M_K . One considers a non-singular flow $(\phi_t)_{t \in \mathbf{R}^+}$ on M_K as given by proposition 2.3. One glues a 3-dimensional piece $\partial M_K \times [0, 1]$ to M_K by identifying $\partial M_K \times \{0\}$ to ∂M_K by the identity-map. One homotopes the flow $(\phi_t)_{t \in \mathbf{R}^+}$ along the fibers $x \times [0, 1]$, $x \in \partial M_K \times \{0\}$, so that the flow obtained on $M_K \bigcup_{Id} \partial M_K \times [0, 1]$ is tangent to the boundary $\partial M_K \times \{1\}$, and defines in restriction to this boundary a singular flow as given by lemma 8.1. As explained precedingly, one now perturbs this new flow in a neighborhood of the boundary $\partial M_K \times \{1\}$ so that the flow $(\psi_t)_{t \in \mathbf{R}}$ eventually constructed defines, in restriction to this boundary, a ∂ -flow. Since the manifold on which this flow is defined is clearly homeomorphic to M_K , we will speak of it as a flow on M_K .

If K is a flat dynamical 2-spine of some 3-manifold M_K , then we will call ∂ -tangent flow on M_K a non-singular flow $(\psi_t)_{t \in \mathbf{R}}$ as constructed above.

Theorem 8.3 *Let K be a flat dynamical 2-spine of a 3-manifold M_K . If $(\psi_t)_{t \in \mathbf{R}}$ is a ∂ -tangent flow on M_K , then $(\psi_t)_{t \in \mathbf{R}}$ admits a cross-section if and only if there exists a positive cocycle $u \in C^1(K; \mathbf{Z})$. Any such positive cocycle defines a cross-section $S_u = r_{M_K}^{-1}(\Gamma_u)$ to $(\psi_t)_{t \in \mathbf{R}}$.*

One proves in [9] that a positive cocycle u defines a cross-section Γ_u to any chosen combinatorial semi-flow on a flat dynamical 2-complex. By construction of a ∂ -tangent flow, one easily proves that the surface $S_u = r_{M_K}^{-1}(\Gamma_u)$ given by lemma 2.7 is a cross-section to $(\psi_t)_{t \in \mathbf{R}}$, if the chosen combinatorial semi-flow is the one used for the construction of $(\psi_t)_{t \in \mathbf{R}}$. Conversely, let us assume that some ∂ -tangent flow $(\psi_t)_{t \in \mathbf{R}}$ admits a cross-section S . Then, isotoping S along $(\psi_t)_{t \in \mathbf{R}}$, one obtains a non-singular foliation of M_K by properly embedded surfaces S_t , transverse to ∂M_K and all homeomorphic to S . The union of a finite number of these surfaces intersects transversely and positively the positive loops in the image of the singular graph of K under the chosen embedding of K in M_K . Therefore, each surface intersects transversely and positively any positive loop of the singular graph. This implies that it defines a positive cohomology-class of $H^1(M_K; \mathbf{Z})$, and thus of $H^1(K; \mathbf{Z})$. Corollary 1.17 implies that any such cohomology-class is represented by a positive cocycle. \diamond

Remark 8.4 In the case of a special dynamic branched surface W , a ∂ -tangent flow is a pseudo-Anosov flow. By definition, from remark 8.2, it admits a periodic orbit in ∂M_W in the lift under r_W^{-1} of any circuit of W . These periodic orbits are the singular periodic orbits of the flow.

References

- [1] R. BENEDETTI and C. PETRONIO ‘A finite graphic calculus for 3-manifolds’, *Manuscripta Mathematica* (3) 88 (1995) 291-310.
- [2] B.G. CASLER ‘An imbedding theorem for connected 3-manifolds with boundary’, *Proceedings of the American Mathematical Society* 16 (1965) 559-566.
- [3] J. CHRISTY ‘Branched surfaces and attractors I: Dynamic branched surfaces’, *Transactions of the American Mathematical Society* (2) 336 (1993) 759-784.
- [4] J. CHRISTY ‘Immersing branched surfaces in dimension three’, *Proceedings of the American Mathematical Society* (3) 115 (1992) 853-861.

- [5] J. CHRISTY ‘Intransitive Anosov flows on 3-manifolds’ Ph.D. dissertation.
- [6] D. FRIED ‘Geometry of cross-sections to flows’, *Topology* (4) 21 (1982) 353-371.
- [7] D. FRIED ‘Fibrations over \mathbf{S}^1 with pseudo-Anosov monodromy’, *Astérisque* 66-67 (1979) 251-266.
- [8] F.B. FULLER ‘On the surface of section and periodic trajectories’ *American Journal of Mathematics* 87 (1965) 473-480.
- [9] F. GAUTERO ‘Dynamical 2-complexes’, to appear in *Geometriae Dedicata*.
- [10] F. GAUTERO ‘Foliations of 2-complexes’, preprint.
- [11] H. IKEDA ‘Inverse limit stability for semi-flows’ *Ergodic Theory and Dynamical Systems* (2) 20 (2000) 453-471.
- [12] S.V. MATVEEV ‘Special spines of piecewise linear manifolds’, *Math. USSR Sbornik* (2) 21 (1973).
- [13] L. MOSHER ‘Surfaces and branched surfaces transverse to pseudo-Anosov flows on 3-manifolds’, *J. Diff. Geom.* 34 (1991) 1-36.
- [14] L. MOSHER ‘Dynamical systems and the homology norm of a 3-manifold I’ *Duke Mathematical Journal* (3) 65 (1992).
- [15] L. MOSHER ‘Dynamical systems and the homology norm of a 3-manifold II’ *Invent. Math.* 107 (1992) 243-281.
- [16] S. SCHWARTZMAN ‘Asymptotic cycles’ *Annals of Mathematics* (2) 66 (1957) 270-284.
- [17] M. SHUB *Global stability of dynamical systems* Springer Verlag (1987).
- [18] W.P. THURSTON ‘A norm for the homology of 3-manifolds’, *Memoirs of the American Mathematical Society* (339) 59 (1986) 99-130.
- [19] R.F. WILLIAMS ‘Expanding Attractors’, *Publications Mathématiques de l’I.H.E.S.* 43 (1974) 169-203.