



HAL
open science

A power amplifier envelope distortion model using direct calculation of polynomial parameters and delay taps

Nicursor Calinoiu, Smail Bachir, Claude Duvanaud

► **To cite this version:**

Nicursor Calinoiu, Smail Bachir, Claude Duvanaud. A power amplifier envelope distortion model using direct calculation of polynomial parameters and delay taps. European Microwave Integrated Circuits Conference (EuMIC), Oct 2011, Manchester, United Kingdom. pp.292 - 295. <hal-00782266>

HAL Id: hal-00782266

<https://hal.science/hal-00782266v1>

Submitted on 29 Jan 2013

HAL is a multi-disciplinary open access archive for the deposit and dissemination of scientific research documents, whether they are published or not. The documents may come from teaching and research institutions in France or abroad, or from public or private research centers.

L'archive ouverte pluridisciplinaire HAL, est destinée au dépôt et à la diffusion de documents scientifiques de niveau recherche, publiés ou non, émanant des établissements d'enseignement et de recherche français ou étrangers, des laboratoires publics ou privés.



HAL Authorization

A Power Amplifier Spectral Asymmetries Modeling Using direct calculation of polynomial parameters and delay taps

Nicusor Calinoiu ¹, Smail Bachir ², Claude Duvanaud ³

*University of Poitiers, Laboratoire d'Automatique et d'Informatique Industrielle
42 av. du Recteur Pineau, 86022 Poitiers, France.*

URL : <http://laii.univ-poitiers.fr/>

¹nicusor.calinoiu@etu.univ-poitiers.fr

²smail.bachir@univ-poitiers.fr

³claudio.duvanaud@univ-poitiers.fr

Abstract—This paper presents a power amplifier(PA) cascade model that uses delay taps to obtain the intermodulation distortion(IMD) asymmetries. A new mathematical method is developed, based on the fourier transform of the gain and phase output, to extract the model parameters and delays for each harmonic. The spectral asymmetries are characterized by distortions in the output envelope signal. Thus, to estimate the model coefficients it requires a method capable to also care for nonlinear phenomenons. The deformed envelope spectral analysis is used to achieve a matrix equation system that provides accurate solutions. To demonstrate the performances of this modeling approach, ADS simulations and real measurement data where used.

I. INTRODUCTION

Development for each generation of mobile telecommunication systems increases the requirements of radio-frequency (RF) power amplifiers (PAs) which became one of the major elements in modern wireless communication systems. In this context, the behavioral modeling of RF PA with nonlinear properties and memory effects, i.e. frequency dependence, has lately been the subject of intensive researches [1]. Developed to achieve fast and accurate performance analysis, models are composed of continuous or discrete time mathematical description of the PA nonlinearity and frequency response.

An essential field of study concern the behavioral modeling of RF PA affected by different types of memory, especially for wide-band applications. Studies on memory effects and measurement results have lead to a classification in two categories: the short-term memory (STM) caused by the frequency response of matching networks and filter group delay and long-term memory (LTM) due to thermal effect, control circuit and bias networks of the transistors [2]. The LTM causes the most critical signal distortion. Consequences are non-constant distortions of the output signal envelope and asymmetries in lower and upper sideband of the output spectrum, depending on the envelope frequency. Hence, development of accurate model of the LTM effect is crucial for the simulation of communication system performances including PA and design of PA linearizer, such as predistorter.

Recently models using memory polynomial with delay taps have been used for optimizing model performances [4] [3]. Such models predict IMD asymmetries accurately by taking in account the history of past input levels. From our point of view, in comparison with model with unit delays, the use of large delays allows to take in account distant past input level, insuring a more accurate prediction of the LTM contribution.

In practice, a main difficulty is the extraction of an optimum set of delay taps. In [3], it's proposed a simplified identification method using sequential implementation based on the sweep of each delay. An empirical sinus function is proposed in [4] to calculate the non-uniform spacing index. Unless these techniques are not optimum in terms of delay determination, the interest of sparse delays has been clearly demonstrated.

In this paper, we propose a method allowing a direct and rigorous determination of model delays. The method is based on Fourier analysis of the output envelope of the amplifier. Using a polynomial description of the AM/AM and AM/PM functions, and a sinusoidal envelope excitation, analytical expressions are established to calculate directly coefficients and delays of the model.

The remainder of this paper is organized as follows. In Section II, we present the model allowing to apply the proposed method and to model envelope distortion and spectral asymmetries. The method is presented and analytical expression of coefficients and delays are given. Section ?? is devoted to the results obtained in ADS software using the method. In section III, the performances are presented using real time domain measurement samples of the output envelope. And, finally, Section IV summarizes and concludes this paper.

II. MODEL FOR ACCURATE SPECTRAL IMD ASYMMETRIES

A. Proposed model

Modeling asymmetries is an objective of first importance to quantify the nonlinear behavior of power amplifier and design a linearization system. Different works have indicated that the output impedance at Intermediate frequency influence the high frequency third order intermodulation asymmetry [5][6][7]. In [6] it has been shown by measurements that the IMD products

at $2f_1 - f_2$ and $2f_2 - f_1$ don't have the same magnitude if the shape of the current envelope is asymmetric. IMD asymmetry had also been demonstrated by introducing a time lag or phase shift between the AM-AM and AM-PM response [8]. These results clearly show that the output amplitude and phase of the amplifier depend on instantaneous and delayed input envelope signal.

Hence, to retrieve asymmetries, the output complex envelope $V_{out}(t)$, is expressed as follows:

$$\tilde{V}_{out}(t) = F_{AMAM}(A_{in}(t)) \cdot \exp^{j(\phi_{in}(t) + F_{AMPM}(A_{in}(t)))} \quad (1)$$

where $A_{in}(t)$ is the amplitude and $\phi_{in}(t)$ the phase of the complex input envelope, taken at time t and at various delayed time $t - \tau_1, t - \tau_2, \dots$

The nonlinear functions F_{AMAM} and F_{AMPM} are instantaneous envelope transfer function, respectively for amplitude and phase. They are described using two polynomial, with an odd-order for AM/AM (p odd) and even-order for AM/PM (q even), as follows:

$$\begin{cases} F_{AMAM}(t) = \sum_{p=1, p \text{ odd}}^N c_p \cdot (A_{in}(t - \tau_p))^p \\ F_{AMPM}(t) = \sum_{q=0, q \text{ even}}^M d_q \cdot (A_{in}(t - \tau_q))^q \end{cases} \quad (2)$$

where c_p and d_q are real numbers and τ_p, τ_q the introduced delays.

From the previous relations, the resulting model can be expressed as a sum of delayed and weighted functions, as illustrated in Fig. 1.

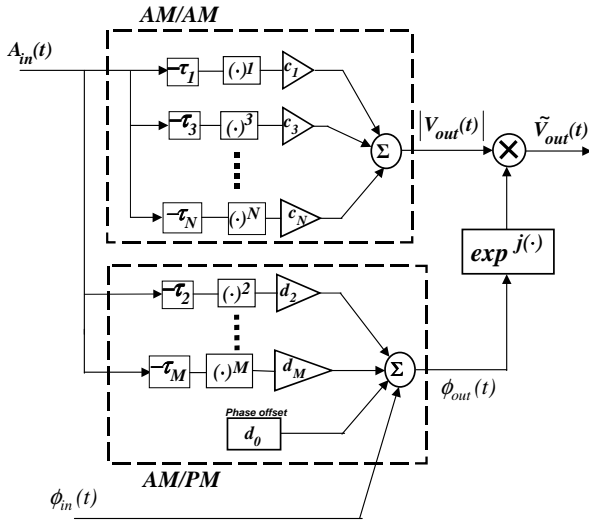

Fig. 1. The Model of the Power Amplifier

By analogy with [3], the proposed model uses several delay taps to model the amplifier. In [3] the model presented is a memory polynomial model using sparse delay taps, followed by nonlinear functions using complex coefficients and an input

complex signal. The proposed model Eq.(2), used two polynomial functions to describe magnitude and phase conversion. This structure allows to implement different delays, or phase shift, between AM/AM and AM/PM functions, as suggested by [8]. In addition, the use of two independent functions allows a direct estimation of the overall model parameters, including delays. The method will be presented in the next section.

B. Parameter determination using the mathematical method based on the Fourier Transform

A crucial point is the determination of the delays for each non linearity order. The proposed method is based on spectral analysis of the output envelope voltage to directly calculate the coefficient and delays. At first, because the model is based on magnitude and phase representations, we have to determine these parameters for the input and output time varying envelope. For that, the quadrature components can be used as illustrated for the output envelope voltage:

$$\begin{cases} \Phi_{out}(t) = \arctan\left(\frac{Q_{out}(t)}{I_{out}(t)}\right) \\ A_{out}(t) = \frac{I_{out}(t)}{\cos(\Phi_{out}(t))} \end{cases} \quad (3)$$

With these signals, we can generate a representation of the instantaneous gain and phase characteristics, called here pseudo-characteristics and noted respectively $F_{AM}^*(t)$ and $F_{PM}^*(t)$, such as:

$$\begin{cases} F_{AM}^*(t) = A_{out}(t) \\ F_{PM}^*(t) = \Phi_{out}(t) - \phi_{in}(t) \end{cases} \quad (4)$$

where $\phi_{in}(t)$ is the phase of the input signal $\tilde{V}_{in}(t)$.

Thus, we can be applied separately on each pseudo functions $F_{AM}^*(t)$ and $F_{PM}^*(t)$ to determine the amplitude and phase at frequencies of interest. From the first relation of equation (2) and for a sinusoidal input at fundamental frequency noted f , extracted Fourier coefficients with $F_{AM}^*(t)$ signal at frequencies $p.f$ (where p is odd) is necessary for the determination of delays taps τ_p and the real weights c_p . Similarly, obtained Fourier coefficients with $F_{PM}^*(t)$ signal at frequencies $q.f$ (where q is even) is necessary for the determination of τ_q and d_q .

If we note $\tilde{A}_n = A_n \cdot e^{j\alpha_n}$ and $\tilde{B}_m = B_m \cdot e^{j\beta_m}$ the complex coefficients obtained by Fourier transform respectively on $F_{AM}^*(t)$ and $F_{PM}^*(t)$, we can write:

$$\begin{cases} F_{AM}^*(t) = \sum_{n=1}^N A_n \cos(n\Omega t - \alpha_n) \quad \text{with } \Omega = 2\pi f \\ F_{PM}^*(t) = \sum_{m=0}^M B_m \cos(m\Omega t - \beta_m) \end{cases} \quad (5)$$

and we define the vectors $\tilde{\underline{y}}_{AM}$ and $\tilde{\underline{y}}_{PM}$ composed by Fourier coefficients as:

$$\begin{aligned} \tilde{\underline{y}}_{AM} &= [\tilde{A}_1 \quad \tilde{A}_3 \quad \dots \quad \tilde{A}_n \quad \dots \quad \tilde{A}_N]^T \\ \tilde{\underline{y}}_{PM} &= [\tilde{B}_0 \quad \tilde{B}_1 \quad \dots \quad \tilde{B}_m \quad \dots \quad \tilde{B}_M]^T \end{aligned} \quad (6)$$

Throughout the paper, $(\cdot)^T$ denotes matrix transposition, \tilde{x} denotes that the parameter x is complex and \underline{x} is a representation of a vector x .

Knowing the input and output envelope voltages and their amplitude and phase spectral components, the identification of the nonlinearities parameters can be done. For a periodical input, an analytical expression of the parameters can be established to calculate directly their value. To simplify the presentation, the following input signal envelope is considered

$$\tilde{V}_{in}(t) = A_{in}(t) = A \cos(\Omega t) \quad (7)$$

Using quadrature components, such an input voltage can be obtained for $I_{in}(t) = A_{in}(t)$ and $Q_{in}(t) = 0$. For delayed input signal and using the development of powers of cosine [9], we can write for p odd and q even:

$$\begin{aligned} A_{in}(\Omega(t-\tau_p))^p &= \frac{A^p}{2^{p-1}} \sum_{k=0}^{(p-1)/2} C_p^k \cos((p-2k)\Omega(t-\tau_p)) \\ A_{in}(\Omega(t-\tau_q))^q &= \frac{A^q}{2^q} \left(C_q^{q/2+2} \sum_{k=0}^{q/2-1} C_q^k \cos((q-2k)\Omega(t-\tau_p)) \right) \end{aligned} \quad (8)$$

where $\Omega(t-\tau_p) = \Omega t + \phi_p$ and $\Omega(t-\tau_q) = \Omega t + \phi_q$. The symbol $C_p^k = \frac{p!}{k!(p-k)!}$ denotes the mathematical combination.

Firstly, we present the approach for AM/AM function and we write the equality between the term \tilde{A}_n of the Fourier result and all the term at the pulsation $n\Omega$ from the development of $\tilde{V}_{in}(t)$:

$$\tilde{A}_n = \sum_{k=0}^N \frac{A^{2k+n}}{2^{2k+n-1}} C_{2k+n}^k \tilde{c}_{2k+n} \quad (9)$$

where $\tilde{c}_p = c_p \cdot e^{j\phi_p}$

By generalizing (9) for each frequency component, we can write the following matrix representation, for i and j odd:

$$\tilde{\underline{y}}_{AM} = K_{AM} \cdot \underline{\theta}_c \quad (10)$$

with:

$$K_{AM_{i,j}} = \begin{cases} \frac{1}{2^{j-1}} C_j^{\frac{j-i}{2}} A^j & j \geq i \\ 0 & \text{otherwise} \end{cases}$$

and $\underline{\theta}_c = [\tilde{c}_1 \ \tilde{c}_3 \ \dots \ \tilde{c}_p \ \dots \ \tilde{c}_N]^T$

Therefore, once we solved Eq.10 we obtain the following recurrence relation which leads to our parameters and delays determination:

$$\tilde{c}_p = \frac{1}{K_{AM_{p,p}}} \left(\tilde{A}_p - \sum_{i=1}^{N-p} \tilde{c}_{p+2i} K_{AM_{p,p+2i}} \right) \quad (11)$$

where the last term $\tilde{c}_N = \frac{\tilde{A}_N}{K_{AM_{N,N}}}$.

The coefficient determination for the AM/PM function approach is similar to AM/AM case. The following recurrence relation are achieved to calculate the AM/PM coefficients and delays:

$$\tilde{d}_q = \frac{1}{K_{PM_{q,q}}} \left(\tilde{B}_q - \sum_{i=1}^{\frac{M-q}{2}} \tilde{d}_{q+2i} K_{AM_{q,q+2i}} \right) \quad (12)$$

and $\tilde{d}_M = \frac{\tilde{B}_M}{K_{PM_{M,M}}}$ and the general form $\tilde{d}_q = d_q \cdot e^{j\phi_q}$ and d_0 real.

The terms $K_{PM_{i,j}}$ are defined as follow for i and j even :

$$K_{PM_{i,j}} = \begin{cases} 1 & \text{for } i = j = 0 \\ \frac{1}{2^j} C_j^{\frac{j}{2}} A^j & \text{for } i = 0, j > 0 \\ \frac{1}{2^{j-1}} C_j^{\frac{j-i}{2}} A^j & \text{for } i \neq 0, j \geq i \\ 0 & \text{otherwise} \end{cases}$$

$$\underline{\theta}_d = [\tilde{d}_0 \ \tilde{d}_2 \ \dots \ \tilde{d}_q \ \dots \ \tilde{d}_M]^T.$$

Fig. (2) summarize the proposed PA characterization method.

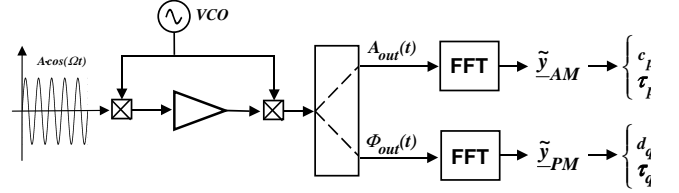

Fig. 2. Block diagram of the proposed method

III. MEASUREMENT RESULTS

The measurement system that has been used in this work is shown in Fig.3. An Agilent N5182A MXG vector signal generator is used for the input signal with a sinusoidal modulating signal applied on I baseband input. The output data is obtained using an Agilent Technologies MXA Signal Analyzer.

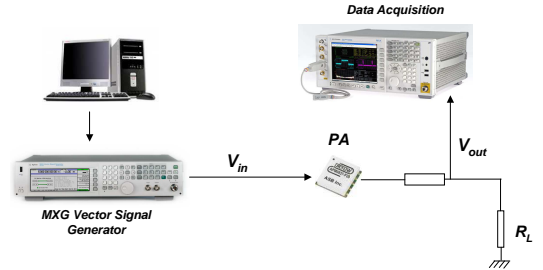

Fig. 3. Measurement Bench

The power amplifier is a commercial APM1855 from ADVANCED SEMICONDUCTOR BUSINESS INC. To apply the proposed method, the PA is driven in saturation with a carrier frequency $f_c = 1,85\text{GHz}$ and a sinusoidal modulating signal at $f = 0,5\text{MHz}$. The output data (I_{out} and Q_{out}) is downloaded from the Signal Analyzer on the PC, else the coefficient calculation is achieved on $F_{AMAM}(\cdot)$ and $F_{AMP}(\cdot)$ characteristics, using MATLAB software.

Figures (4) and (5) show the measured I_{out} and Q_{out} in comparison with their estimations using a 5th order polynomial function achieved by applying a Fourier transform and the analytical method.

The parameters and delays, for AM/AM and AM/PM responses, are shown below.

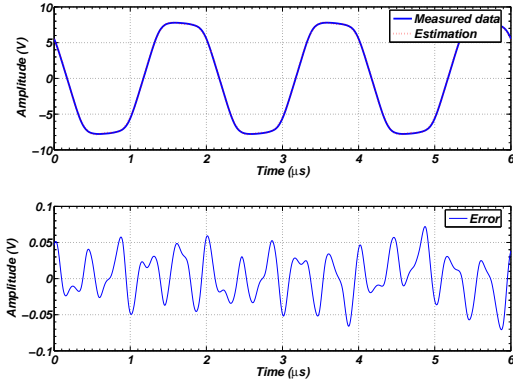

Fig. 4. Comparison between the measurements and the estimation(channel I)

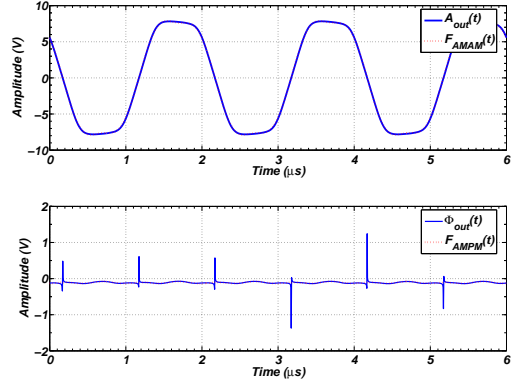

Fig. 6. Comparison between the measured and the estimated magnitude and phase

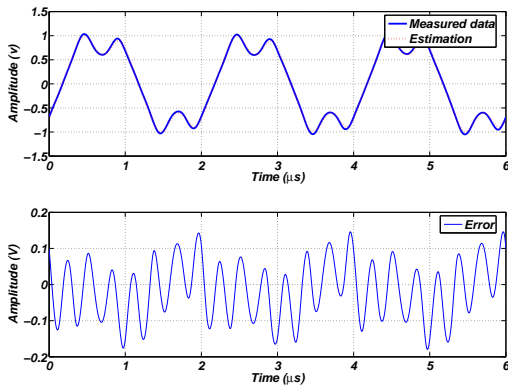

Fig. 5. Comparison between the measurements and the estimation(channel Q)

$$\begin{cases} c_1 = 8,04 \\ c_3 = 5,30 \\ c_5 = 8,94 \end{cases}$$

with delays $\tau_1 = 1,34 \mu s$, $\tau_3 = 1,83 \mu s$ and $\tau_5 = 0,11 \mu s$, and:

$$\begin{cases} d_0 = -2,660 \cdot 10^{-1} \\ d_2 = 1,87 \cdot 10^{-1} \\ d_4 = 1,60 \cdot 10^{-1} \end{cases}$$

with delays $\tau_2 = 1,53 \mu s$ and $\tau_6 = 0,034 \mu s$.

Fig.6 presents a comparison between the variations for the measured $A_{out}(t)$ and $\Phi_{out}(t)$ and the estimated $F_{AMAM}(t)$ and $F_{AMPM}(t)$, described in Eq.(2) and (3). This graphical representation confirms that the delay introduction in each function is a solution to obtain a precise estimation model.

IV. CONCLUSION

A base band PA model which describes the magnitude and phase nonlinear characteristics of IMD asymmetries was presented. A new spectral analysis method was performed, that

allowed us to obtain a frequency behavior in case of nonlinear phenomena, for the PA modeling.

The model is based on a mathematical approach that allows the evaluation of the spectral representation under a matrix equation system. Because the model polynomial expression offers the opportunity to treat separately each harmonic, the Fourier transform is used for all parameter determination. The addition of delays added a better accuracy to the model, leading to other possibilities in characterizing the PA.

In the end, to demonstrate this mathematical approach, simulated and real data were tasted. The results validate the previous spectral analysis method which can represent the IMD asymmetries.

REFERENCES

- [1] J.C. Pedro, S. A. Maas, *A Comparative Overview of Microwave and Wireless Power-Amplifier Behavioral Modeling Approaches*, IEEE Trans. on MTT, VOL. 53, NO. 4, pp. 1150-1163, APRIL 2005
- [2] E. Ngoya, C. Quindroit, J.M. Nbus *On the Continuous-Time Model for Nonlinear-Memory Modeling of RF Power Amplifiers*, IEEE Trans. on MTT, VOL. 57, NO. 12, pp. 3278-3292, DECEMBER 2009
- [3] H. Ku and J. S. Kenney, *Behavioral Modeling of Nonlinear RF Power Amplifiers Considering Memory Effects*, IEEE Trans. on Microwave Theory and Techniques, Vol. 51, No. 12, December 2003
- [4] A. Ahmed, M. O. Abdalla, E. S. Mengistu, and G. Kompa, *Power Amplifier Modeling Using Memory Polynomial with Non-uniform Delay Taps*, 34th European Microwave Conference, Amsterdam 2004
- [5] N. B. Carvalho and J. C. Pedro, *Two-tone IMD asymmetry in microwave power amplifiers*, Microwave Symposium Digest, 2000 IEEE MTT-S International, Vol. 1, pp. 445-448, Boston, 2000
- [6] D. J. Williams, J. Leckey and P. J. Tasker, *A Study of the Effect of Envelope Impedance on Intermodulation Asymmetry Using a Two-Tone Time Domain Measurement System*, Microwave Symposium Digest, 2002 IEEE MTT-S International, Vol. 3, pp. 1841-1844, Seattle, WA, 2002
- [7] C. Duvaud, F. Robin, S. Dardenne, F. Huin, L. Dascalescu, *Effects of low-frequency drain termination and injection on nonlinear amplifier performances*, International Journal of RF and Microwave Computer-Aided Engineering, Vol. 15, Issue 2, pp. 231-240, March 2005
- [8] S. C. Cripps *Advanced Techniques in RF Power Amplifier Design*, Artech House microwave library, ISBN 1-58053-282-9, 2002
- [9] P. Suchanek, V. Haasz, *Approaches to the ADC transfer function modelling*, 12th International Workshop on ADC Modeling and testing, IMEKO-IWADC, Iasi CERMI Publishing House, pp 127-130, 2007.