



HAL
open science

Prodsimplicial neighborly polytopes

Benjamin Matschke, Julian Pfeifle, Vincent Pilaud

► **To cite this version:**

Benjamin Matschke, Julian Pfeifle, Vincent Pilaud. Prodsimplicial neighborly polytopes. *Discrete and Computational Geometry*, 2011, 46 (1), pp.100-131. 10.1007/s00454-010-9311-y . hal-00777936

HAL Id: hal-00777936

<https://hal.science/hal-00777936>

Submitted on 18 Jan 2013

HAL is a multi-disciplinary open access archive for the deposit and dissemination of scientific research documents, whether they are published or not. The documents may come from teaching and research institutions in France or abroad, or from public or private research centers.

L'archive ouverte pluridisciplinaire **HAL**, est destinée au dépôt et à la diffusion de documents scientifiques de niveau recherche, publiés ou non, émanant des établissements d'enseignement et de recherche français ou étrangers, des laboratoires publics ou privés.

PRODSIMPLICIAL-NEIGHBORLY POLYTOPES

BENJAMIN MATSCHKE, JULIAN PFEIFLE, AND VINCENT PILAUD

ABSTRACT. Simultaneously generalizing both neighborly and neighborly cubical polytopes, we introduce *PSN polytopes*: their k -skeleton is combinatorially equivalent to that of a product of r simplices.

We construct PSN polytopes by three different methods, the most versatile of which is an extension of Sanyal & Ziegler’s “projecting deformed products” construction to products of arbitrary simple polytopes. For general r and k , the lowest dimension we achieve is $2k+r+1$.

Using topological obstructions similar to those introduced by Sanyal to bound the number of vertices of Minkowski sums, we show that this dimension is minimal if we additionally require that the PSN polytope is obtained as a projection of a polytope that is combinatorially equivalent to the product of r simplices, when the dimensions of these simplices are all large compared to k .

1. INTRODUCTION

1.1. Definitions. Let Δ_n denote the n -dimensional simplex. For any tuple $\underline{n} := (n_1, \dots, n_r)$ of integers, we denote by $\Delta_{\underline{n}}$ the product of simplices $\Delta_{n_1} \times \dots \times \Delta_{n_r}$. This is a polytope of dimension $\sum n_i$, whose non-empty faces are obtained as products of non-empty faces of the simplices $\Delta_{n_1}, \dots, \Delta_{n_r}$. For example, Figure 1 represents the graphs of $\Delta_i \times \Delta_6$, for $i \in \{1, 2, 3\}$.

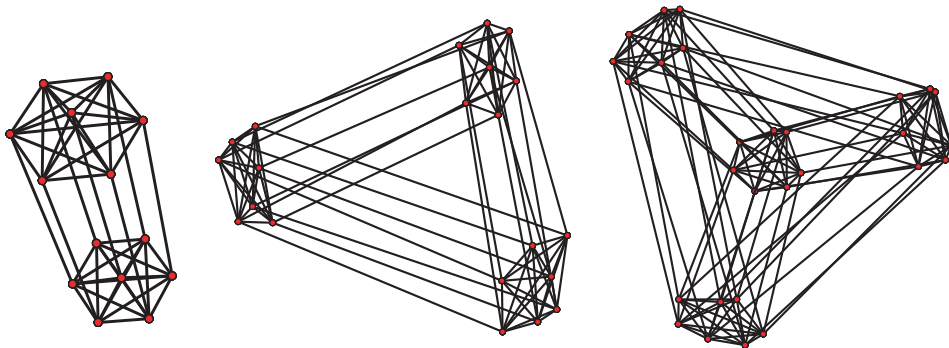

FIGURE 1. The graphs of the products $\Delta_{(i,6)} = \Delta_i \times \Delta_6$, for $i \in \{1, 2, 3\}$.

We are interested in polytopes with the same “initial” structure as these products.

Benjamin Matschke was supported by DFG research group Polyhedral Surfaces and by Deutsche Telekom Stiftung. Julian Pfeifle was supported by grants MTM2006-01267 and MTM2008-03020 from the Spanish Ministry of Education and Science and 2009SGR1040 from the Generalitat de Catalunya. Vincent Pilaud was partially supported by grant MTM2008-04699-C03-02 of the Spanish Ministry of Education and Science.

Definition 1.1. Let $k \geq 0$ and $\underline{n} := (n_1, \dots, n_r)$, with $r \geq 1$ and $n_i \geq 1$ for all i . A convex polytope in some Euclidean space is (k, \underline{n}) -prodsimplicial-neighborly — or (k, \underline{n}) -PSN for short — if its k -skeleton is combinatorially equivalent to that of $\Delta_{\underline{n}} := \Delta_{n_1} \times \dots \times \Delta_{n_r}$.

We choose the term “prodsimplicial” to shorten “product simplicial”. This definition is essentially motivated by two particular classes of PSN polytopes:

- (1) *neighborly* polytopes arise when $r = 1$;
- (2) *neighborly cubical* polytopes [JS07, SZ09] arise when $\underline{n} = (1, 1, \dots, 1)$.

Remark 1.2. In the literature, a polytope is k -neighborly if any subset of at most k of its vertices forms a face. Observe that such a polytope is $(k - 1, n)$ -PSN with our notation.

The product $\Delta_{\underline{n}}$ is a (k, \underline{n}) -PSN polytope of dimension $\sum n_i$, for each k with $0 \leq k \leq \sum n_i$. We are naturally interested in finding (k, \underline{n}) -PSN polytopes of smaller dimensions. For example, the cyclic polytope $C_{2k+2}(n+1)$ is a (k, n) -PSN polytope of dimension $2k+2$. We denote by $\delta(k, \underline{n})$ the smallest possible dimension of a (k, \underline{n}) -PSN polytope.

PSN polytopes can be obtained by projecting the product $\Delta_{\underline{n}}$, or a combinatorially equivalent polytope, onto a smaller subspace. For example, the cyclic polytope $C_{2k+2}(n+1)$ (just like any polytope with $n+1$ vertices) can be seen as a projection of the simplex Δ_n to \mathbb{R}^{2k+2} .

Definition 1.3. A (k, \underline{n}) -PSN polytope is (k, \underline{n}) -projected-prodsimplicial-neighborly — or (k, \underline{n}) -PPSN for short — if it is a projection of a polytope that is combinatorially equivalent to $\Delta_{\underline{n}}$.

We denote by $\delta_{pr}(k, \underline{n})$ the smallest possible dimension of a (k, \underline{n}) -PPSN polytope.

1.2. Outline and main results. The present paper may be naturally divided into two parts. In the first part, we present three methods for constructing low-dimensional PPSN polytopes:

- (1) Reflections of cyclic polytopes;
- (2) Minkowski sums of cyclic polytopes;
- (3) Deformed Product constructions in the spirit of Sanyal & Ziegler [Zie04, SZ09].

The second part derives topological obstructions for the existence of such objects, using techniques developed by Sanyal in [San09] (see also [RS09]) to bound the number of vertices of Minkowski sums. In view of these obstructions, our constructions in the first part turn out to be optimal for a wide range of parameters.

We devote the remainder of the introduction to highlighting our most relevant results. To facilitate the navigation in the article, we label each result by the number it actually receives later on.

Constructions. Our first non-trivial example is a $(k, (1, n))$ -PSN polytope in dimension $2k+2$, obtained by reflecting the cyclic polytope $C_{2k+2}(n+1)$ through a well-chosen hyperplane:

Proposition 2.3. For any $k \geq 0$, $n \geq 2k+2$ and $\lambda \in \mathbb{R}$ sufficiently large, the polytope

$$P := \text{conv} \left(\{(t_i, \dots, t_i^{2k+2})^T \mid i \in [n+1]\} \cup \{(t_i, \dots, t_i^{2k+1}, \lambda - t_i^{2k+2})^T \mid i \in [n+1]\} \right)$$

is a $(k, (1, n))$ -PSN polytope of dimension $2k+2$.

For example, this provides us with a 4-dimensional polytope whose graph is the cartesian product $K_2 \times K_n$, for any $n \geq 3$.

Next, forming a well-chosen Minkowski sum of cyclic polytopes yields explicit coordinates for (k, \underline{n}) -PPSN polytopes:

Theorem 2.6. *Let $k \geq 0$ and $\underline{n} := (n_1, \dots, n_r)$ with $r \geq 1$ and $n_i \geq 1$ for all i . There exist index sets $I_1, \dots, I_r \subset \mathbb{R}$, with $|I_i| = n_i$ for all i , such that the polytope*

$$P := \text{conv}\{w_{a_1, \dots, a_r} \mid (a_1, \dots, a_r) \in I_1 \times \dots \times I_r\} \subset \mathbb{R}^{2k+r+1}$$

is (k, \underline{n}) -PPSN, where $w_{a_1, \dots, a_r} := (a_1, \dots, a_r, \sum_{i \in [r]} a_i^2, \dots, \sum_{i \in [r]} a_i^{2k+2})^T$. Consequently,

$$\delta(k, \underline{n}) \leq \delta_{pr}(k, \underline{n}) \leq 2k + r + 1.$$

For $r = 1$ we recover neighborly polytopes.

Finally, we extend Sanyal & Ziegler’s technique of “projecting deformed products of polygons” [Zie04, SZ09] to products of arbitrary simple polytopes: given a polytope P that is combinatorially equivalent to a product of simple polytopes, we exhibit a suitable projection that preserves the complete k -skeleton of P . More concretely, we describe how to use colorings of the graphs of the polar polytopes of the factors in the product to raise the dimension of the preserved skeleton. The basic version of this technique yields the following result:

Proposition 3.4. *Let P_1, \dots, P_r be simple polytopes of respective dimension n_i , and with m_i many facets. Let $\chi_i := \chi(\text{sk}_1 P_i^\Delta)$ denote the chromatic number of the graph of the polar polytope P_i^Δ . For a fixed integer $d \leq \sum_{i=1}^r n_i$, let t be maximal such that $\sum_{i=1}^t n_i \leq d$. Then there exists a d -dimensional polytope whose k -skeleton is combinatorially equivalent to that of the product $P_1 \times \dots \times P_r$ provided*

$$0 \leq k \leq \sum_{i=1}^r (n_i - m_i) + \sum_{i=1}^t (m_i - \chi_i) + \left\lfloor \frac{1}{2} \left(d - 1 + \sum_{i=1}^t (\chi_i - n_i) \right) \right\rfloor.$$

A family of polytopes that minimize the last summand are products of *even polytopes* (all 2-dimensional faces have an even number of vertices). See Example 3.5 for the details, and the end of Section 3.1 for extensions of this technique.

Specializing the factors to simplices provides another construction of PPSN polytopes. When some of these simplices are small compared to k , this technique in fact yields our best examples of PPSN polytopes:

Theorem 3.8. *For any $k \geq 0$ and $\underline{n} := (n_1, \dots, n_r)$ with $1 = n_1 = \dots = n_s < n_{s+1} \leq \dots \leq n_r$,*

$$\delta_{pr}(k, \underline{n}) \leq \begin{cases} 2(k+r) - s - t & \text{if } 3s \leq 2k + 2r, \\ 2(k+r-s) + 1 & \text{if } 3s = 2k + 2r + 1, \\ 2(k+r-s+1) & \text{if } 3s \geq 2k + 2r + 2, \end{cases}$$

where $t \in \{s, \dots, r\}$ is maximal such that $3s + \sum_{i=s+1}^t (n_i + 1) \leq 2k + 2r$.

If $n_i = 1$ for all i , we recover the neighborly cubical polytopes of [SZ09].

Obstructions. In order to derive lower bounds on the minimal dimension $\delta_{pr}(k, \underline{n})$ that a (k, \underline{n}) -PPSN polytope can have, we apply and extend a method due to Sanyal [San09]. For any projection which preserves the k -skeleton of $\Delta_{\underline{n}}$, we use Gale duality to construct a simplicial complex that can be embedded in a certain dimension. The argument is then a topological obstruction based on Sarkaria's criterion for the embeddability of a simplicial complex in terms of colorings of Kneser graphs [Mat03]. We obtain the following result:

Corollary 4.13. *Let $\underline{n} := (n_1, \dots, n_r)$ with $1 = n_1 = \dots = n_s < n_{s+1} \leq \dots \leq n_r$.*

(1) *If*

$$0 \leq k \leq \sum_{i=s+1}^r \left\lfloor \frac{n_i - 2}{2} \right\rfloor + \max \left\{ 0, \left\lfloor \frac{s-1}{2} \right\rfloor \right\},$$

then $\delta_{pr}(k, \underline{n}) \geq 2k + r - s + 1$.

(2) *If $k \geq \lfloor \frac{1}{2} \sum_i n_i \rfloor$ then $\delta_{pr}(k, \underline{n}) \geq \sum_i n_i$.*

In particular, the upper and lower bounds provided by Theorem 2.6 and Corollary 4.13 match over a wide range of parameters:

Theorem 1.4. *Let $\underline{n} := (n_1, \dots, n_r)$ with $r \geq 1$ and $n_i \geq 2$ for all i . For any k such that $0 \leq k \leq \sum_{i \in [r]} \lfloor \frac{n_i - 2}{2} \rfloor$, the smallest (k, \underline{n}) -PPSN polytope has dimension exactly $2k + r + 1$. In other words:*

$$\delta_{pr}(k, \underline{n}) = 2k + r + 1.$$

Remark 1.5. During the final stages of completing this paper, we learned that Rörig and Sanyal [RS09] also applied Sanyal's topological obstruction method to derive lower bounds on the target dimension of a projection preserving skeleta of different kind of products (products of polygons, products of simplices, and wedge products of polytopes). In particular, for a product $\Delta_n \times \dots \times \Delta_n$ of r identical simplices, $r \geq 2$, they obtain our Theorem 4.9 and a result (their Theorem 4.5) that is only slightly weaker than Theorem 4.12 in this setting (compare with Sections 4.5 and 4.6).

2. CONSTRUCTIONS FROM CYCLIC POLYTOPES

Let $t \mapsto \mu_d(t) := (t, t^2, \dots, t^d)^T$ be the *moment curve* in \mathbb{R}^d , $t_1 < t_2 < \dots < t_n$ be n distinct real numbers and $C_d(n) := \text{conv}\{\mu_d(t_i) \mid i \in [n]\}$ denote the *cyclic polytope* in its realization on the moment curve. We refer to [Zie95, Theorem 0.7] and [dLRS10, Corollary 6.1.9] for combinatorial properties of $C_d(n)$, in particular *Gale's Evenness Criterion* which characterizes the index sets of *upper* and *lower* facets of $C_d(n)$.

Cyclic polytopes yield our first examples of PSN polytopes:

Example 2.1. For any integers $k \geq 0$ and $n \geq 2k + 2$, the cyclic polytope $C_{2k+2}(n+1)$ is (k, n) -PPSN.

Example 2.2. For any $k \geq 0$ and $\underline{n} := (n_1, \dots, n_r)$ with $r \geq 1$ and $n_i \geq 1$ for all i , define $I := \{i \in [r] \mid n_i \geq 2k + 3\}$. Then the product

$$\prod_{i \in I} C_{2k+2}(n_i + 1) \times \prod_{i \notin I} \Delta_{n_i}$$

is a (k, \underline{n}) -PPSN polytope of dimension $(2k + 2)|I| + \sum_{i \notin I} n_i$ (which is smaller than $\sum n_i$ when I is nonempty). Consequently,

$$\delta(k, \underline{n}) \leq \delta_{pr}(k, \underline{n}) \leq (2k + 2)|I| + \sum_{i \notin I} n_i.$$

2.1. Reflections of cyclic polytopes. Our next example deals with the special case of the product $\Delta_1 \times \Delta_n$ of a segment with a simplex. Using products of cyclic polytopes as in Example 2.2, we can realize the k -skeleton of this polytope in dimension $2k + 3$. We can lower this dimension by 1 by reflecting the cyclic polytope $C_{2k+2}(n+1)$ through a well-chosen hyperplane:

Proposition 2.3. *For any $k \geq 0$, $n \geq 2k + 2$ and $\lambda \in \mathbb{R}$ sufficiently large, the polytope*

$$P := \text{conv} \left(\{(t_i, \dots, t_i^{2k+2})^T \mid i \in [n+1]\} \cup \{(t_i, \dots, t_i^{2k+1}, \lambda - t_i^{2k+2})^T \mid i \in [n+1]\} \right)$$

is a $(k, (1, n))$ -PSN polytope of dimension $2k + 2$.

Proof. The polytope P is obtained as the convex hull of two copies of the cyclic polytope $C_{2k+2}(n+1)$. The first one $Q := \text{conv}\{\mu_{2k+2}(t_i) \mid i \in [n+1]\}$ lies on the moment curve μ_{2k+2} , while the second one is obtained as a reflection of Q with respect to a hyperplane that is orthogonal to the last coordinate vector u_{2k+2} and sufficiently far away. During this process,

- (1) we destroy all the faces of Q only contained in upper facets of Q ;
- (2) we create prisms over faces of Q that lie in at least one upper and one lower facet of Q . In other words, we create prisms over the faces of Q strictly preserved under the orthogonal projection $\pi : \mathbb{R}^{2k+2} \rightarrow \mathbb{R}^{2k+1}$ with kernel $\mathbb{R}u_{2k+2}$.

The projected polytope $\pi(Q)$ is nothing but the cyclic polytope $C_{2k+1}(n+1)$. Since this polytope is k -neighborly, any face F of dimension at most $k - 1$ in Q is strictly preserved by π . Thus, we take the prism over all faces of Q of dimension at most $k - 1$.

Thus, in order to complete the proof that the k -skeleton of P is that of $\Delta_1 \times \Delta_n$, it is enough to show that any k -face of Q remains in P . This is obviously the case if this k -face is also a k -face of $C_{2k+1}(n+1)$, and follows from the next combinatorial lemma otherwise. \square

Lemma 2.4. *A k -face of $C_{2k+2}(n+1)$ which is not a k -face of $C_{2k+1}(n+1)$ is only contained in lower facets of $C_{2k+2}(n+1)$.*

Proof. Let $F \subset [n+1]$ be a k -face of $C_{2k+2}(n+1)$. We assume that F is contained in at least one upper facet $G \subset [n+1]$ of $C_{2k+2}(n+1)$. Since the size of the final block of an upper facet of a cyclic polytope is odd, G contains $n+1$. If $n+1 \in G \setminus F$, then $G \setminus \{n+1\}$ is a facet of $C_{2k+1}(n+1)$ containing F . Otherwise, $n+1 \in F$, and $F' := F \setminus \{n+1\}$ has only k elements. Thus, F' is a face of $C_{2k}(n)$, and can be completed to a facet of $C_{2k}(n)$. Adding the index $n+1$ back to this facet, we obtain a facet of $C_{2k+1}(n+1)$ containing F . In both cases, we have shown that F is a k -face of $C_{2k+1}(n+1)$. \square

2.2. Minkowski sums of cyclic polytopes. Our next examples are Minkowski sums of cyclic polytopes. We first describe an easy construction that avoids all technicalities, but only yields (k, \underline{n}) -PPSN polytopes in dimension $2k + 2r$. After that, we show how to reduce the dimension to $2k + r + 1$, which according to Corollary 4.13 is best possible for large n_i 's.

Proposition 2.5. *Let $k \geq 0$ and $\underline{n} := (n_1, \dots, n_r)$ with $r \geq 1$ and $n_i \geq 1$ for all i . For any pairwise disjoint index sets $I_1, \dots, I_r \subset \mathbb{R}$, with $|I_i| = n_i$ for all i , the polytope*

$$P := \text{conv}\{v_{a_1, \dots, a_r} \mid (a_1, \dots, a_r) \in I_1 \times \dots \times I_r\} \subset \mathbb{R}^{2k+2r}$$

is (k, \underline{n}) -PPSN, where

$$v_{a_1, \dots, a_r} := \left(\sum_{i \in [r]} a_i, \sum_{i \in [r]} a_i^2, \dots, \sum_{i \in [r]} a_i^{2k+2r} \right)^T \in \mathbb{R}^{2k+2r}.$$

Proof. The vertex set of $\Delta_{\underline{n}}$ is indexed by $I_1 \times \dots \times I_r$. Let $A := A_1 \times \dots \times A_r \subset I_1 \times \dots \times I_r$ define a k -face of $\Delta_{\underline{n}}$. Consider the polynomial

$$f(t) := \prod_{i \in [r]} \prod_{a \in A_i} (t - a)^2 = \sum_{j=0}^{2k+2r} c_j t^j.$$

Since A indexes a k -face of $\Delta_{\underline{n}}$, we know that $\sum |A_i| = k + r$, so that the degree of $f(t)$ is indeed $2k + 2r$. Since $f(t) \geq 0$, and equality holds if and only if $t \in \bigcup_{i \in [r]} A_i$, the inner product $(c_1, \dots, c_{2k+2r}) \cdot v_{a_1, \dots, a_r}$ equals

$$(c_1, \dots, c_{2k+2r}) \begin{pmatrix} \sum_{i \in [r]} a_i \\ \vdots \\ \sum_{i \in [r]} a_i^{2k+2r} \end{pmatrix} = \sum_{i \in [r]} \sum_{j=1}^{2k+2r} c_j a_i^j = \sum_{i \in [r]} (f(a_i) - c_0) \geq -rc_0,$$

with equality if and only if $(a_1, \dots, a_r) \in A$. Thus, A indexes a face of P defined by the linear inequality $\sum_{i \in [r]} c_i x_i \geq -rc_0$.

We thus obtain that the k -skeleton of P completely contains the k -skeleton of $\Delta_{\underline{n}}$. Since P is furthermore a projection of $\Delta_{\underline{n}}$, the faces of $\Delta_{\underline{n}}$ are the only candidates to be faces of P . We conclude that the k -skeleton of P is actually combinatorially equivalent to that of $\Delta_{\underline{n}}$. \square

To realize the k -skeleton of $\Delta_{n_1} \times \dots \times \Delta_{n_r}$ even in dimension $2k + r + 1$, we slightly modify this construction in the following way.

Theorem 2.6. *Let $k \geq 0$ and $\underline{n} := (n_1, \dots, n_r)$ with $r \geq 1$ and $n_i \geq 1$ for all i . There exist pairwise disjoint index sets $I_1, \dots, I_r \subset \mathbb{R}$, with $|I_i| = n_i$ for all i , such that the polytope*

$$P := \text{conv}\{w_{a_1, \dots, a_r} \mid (a_1, \dots, a_r) \in I_1 \times \dots \times I_r\} \subset \mathbb{R}^{2k+r+1}$$

is (k, \underline{n}) -PPSN, where

$$w_{a_1, \dots, a_r} := \left(a_1, \dots, a_r, \sum_{i \in [r]} a_i^2, \dots, \sum_{i \in [r]} a_i^{2k+2} \right)^T \in \mathbb{R}^{2k+r+1}.$$

Proof. We will choose the index sets I_1, \dots, I_r to be sufficiently separated in a sense that will be made explicit later in the proof. For each k -face F of $\Delta_{\underline{n}}$, indexed by $A_1 \times \dots \times A_r \subset I_1 \times \dots \times I_r$, our choice of the I_i 's will ensure the existence of a monic polynomial

$$f_F(t) := \sum_{j=0}^{2k+2} c_j t^j,$$

which, for all $i \in [r]$, can be decomposed as

$$f_F(t) = Q_i(t) \prod_{a \in A_i} (t - a)^2 + s_i t + r_i,$$

where $Q_i(t)$ is an everywhere positive polynomial of degree $2k + 2 - 2|A_i|$, and $r_i, s_i \in \mathbb{R}$. Assuming the existence of such a decomposable polynomial f_F , we built from its coefficients the vector

$$n_F := (s_1 - c_1, \dots, s_r - c_1, -c_2, -c_3, \dots, -c_{2k+2}) \in \mathbb{R}^{2k+r+1},$$

and prove that n_F is normal to a supporting hyperplane for F . Indeed, for any r -tuple $(a_1, \dots, a_r) \in I_1 \times \dots \times I_r$, the inner product $n_F \cdot w_{a_1, \dots, a_r}$ satisfies the following inequality:

$$\begin{aligned} n_F \cdot w_{a_1, \dots, a_r} &= \sum_{i \in [r]} \left(s_i a_i - \sum_{j=1}^{2k+2} c_j a_i^j \right) \\ &= \sum_{i \in [r]} (s_i a_i + c_0 - f_F(a_i)) \\ &= \sum_{i \in [r]} \left(c_0 - Q_i(a_i) \prod_{a \in A_i} (a_i - a)^2 - r_i \right) \leq r c_0 - \sum_{i \in [r]} r_i. \end{aligned}$$

Since the Q_i 's are everywhere positive, equality holds if and only if $(a_1, \dots, a_r) \in A_1 \times \dots \times A_r$. Given the existence of a decomposable polynomial f_F , this proves that $A_1 \times \dots \times A_r$ indexes all w_{a_1, \dots, a_r} 's that lie on a face F' in P , and they of course span F' by definition of P . To prove that F' is combinatorially equivalent to F , it suffices to show that each $w_{a_1, \dots, a_r} \in F'$ is in fact a vertex of P , since P is a projection of $\Delta_{\underline{n}}$. This can be shown with the normal vector $(2a_1, \dots, 2a_r, -1, 0, \dots, 0)$, using the same calculation as before.

As in the proof of Proposition 2.5, this ensures that the k -skeleton of P completely contains the k -skeleton of $\Delta_{\underline{n}}$, and we argue that they actually coincide since P is furthermore a projection of $\Delta_{\underline{n}}$.

Before showing how to choose the index sets I_i that enable us to construct the polynomials f_F in general, we illustrate the proof on the smallest example. \square

Example 2.7. Let $k = 1$ and $\underline{n} := (n_1, n_2)$. Choose the index sets $I_1, I_2 \subset \mathbb{R}$ with $|I_1| = n_1$, $|I_2| = n_2$ and separated in the sense that the largest element of I_1 be smaller than the smallest element of I_2 . For any 1-dimensional face F of $\Delta_{\underline{n}}$ indexed by $\{a, b\} \times \{c\} \subset I_1 \times I_2$, consider the polynomial f_F of degree $2k + 2 = 4$:

$$f_F(t) := (t - a)^2(t - b)^2 = (t^2 + \alpha t + \beta)(t - c)^2 + s_2 t + r_2,$$

where

$$\begin{aligned} \alpha &= 2(-a - b + c), \\ \beta &= a^2 + b^2 + 3c^2 + 4ab - 4ac - 4bc, \\ r_2 &= a^2 b^2 - \beta c^2, \\ s_2 &= -2a^2 b - 2ab^2 - \alpha c^2 + 2\beta c. \end{aligned}$$

Since the index sets I_1, I_2 are separated, the discriminant $\alpha^2 - 4\beta = -8(c - a)(c - b)$ is negative, which implies that the polynomial $Q_2(t) = t^2 + \alpha t + \beta$ is positive for all values of t . A symmetric formula holds for the 1-dimensional faces of $\Delta_{\underline{n}}$ whose index sets are of the form $\{a\} \times \{b, c\} \subset I_1 \times I_2$.

Proof of Theorem 2.6, continued. We still need to show how to choose the index sets I_i that enable us to construct the polynomials f_F in general. Once we have chosen these index sets, finding f_F is equivalent to the task of finding polynomials $Q_i(t)$ such that

- (i) $Q_i(t)$ is monic of degree $2k + 2 - 2|A_i|$.
- (ii) The r polynomials $f_i(t) := Q_i(t) \prod_{a \in A_i} (t - a)^2$ are equal, up to the coefficients on t^0 and t^1 .
- (iii) $Q_i(t) > 0$ for all $t \in \mathbb{R}$.

The first two items form a linear system equations on the coefficients of the $Q_i(t)$'s which has the same number of equations as variables, namely $2k(r - 1)$. We show that it has a unique solution if one chooses the correct index sets I_i , and we postpone the discussion of requirement (iii) to the end of the proof. To do this, choose distinct reals $\bar{a}_1, \dots, \bar{a}_r \in \mathbb{R}$ and look at the similar equation system:

- (i) $\bar{Q}_i(t)$ are monic polynomials of degree $2k + 2 - 2|A_i|$.
- (ii) The r polynomials $\bar{f}_i(t) := \bar{Q}_i(t)(t - \bar{a}_i)^{2|A_i|}$ are equal, up to the coefficients on t^0 and t^1 .

The first equation system moves into the second when we deform the points of the sets A_i continuously to \bar{a}_i , respectively. By continuity of the determinant, if the second equation system has a unique solution then so has the first equation system as long as we chose the sets I_i close enough to the \bar{a}_i 's for all i . Observe that in the end, we can fulfill all these closeness conditions required for all k -faces of Δ_n since there are only finitely many k -faces.

Note that a polynomial $\bar{f}_i(t)$ of degree $2k + 2$ has the form

$$(1) \quad \bar{Q}_i(t)(t - \bar{a}_i)^{2|A_i|} + s_i t + r_i,$$

for a monic polynomial \bar{Q}_i and some reals s_i and r_i if and only if $\bar{f}_i''(t)$ has the form

$$(2) \quad R_i(t)(t - \bar{a}_i)^{2(|A_i|-1)},$$

for some polynomial $R_i(t)$ with leading coefficient $(2k + 2)(2k + 1)$. The backward direction can be settled by assuming, without loss of generality, that $\bar{a}_i = 0$. Indeed, otherwise make a change of variables $(t - \bar{a}_i) \mapsto t$ and then integrate (2) twice (with constants of integration equal to zero) to obtain (1).

Therefore the second equation system is equivalent to the following third one:

- (i) $R_i(t)$ are polynomials of degree $2k - 2(|A_i| - 1)$ with leading coefficient $(2k + 2)(2k + 1)$.
- (ii) The r polynomials $g_i(t) := R_i(t)(t - \bar{a}_i)^{2(|A_i|-1)}$ all equal the same polynomial, say $g(t)$.

Since $\sum_i 2(|A_i| - 1) = 2k$, this system of equations has the unique solution

$$R_i(t) = (2k + 2)(2k + 1) \prod_{j \neq i} (t - \bar{a}_j)^{2(|A_j|-1)},$$

with

$$g(t) = (2k + 2)(2k + 1) \prod_{j \in [r]} (t - \bar{a}_j)^{2(|A_j|-1)}.$$

Therefore, the first two systems of equations both have a unique solution (as long as the I_i 's are chosen sufficiently close to the a_i 's). It thus only remains to deal with the positivity requirement (iii).

In the unique solution of the second equation system, the polynomial $\bar{f}_i(t)$ is obtained by integrating $g_i(t)$ twice with some specific integration constants. For a fixed i , we can again assume $\bar{a}_i = 0$. Then both integration constants were chosen to be zero for this i , hence $\bar{f}_i(0) = \bar{f}_i'(0) = 0$. Since g_i is non-negative and zero only at isolated points, \bar{f}_i is strictly

convex, hence non-negative and zero only at $t = 0$. Therefore $\bar{Q}_i(t)$ is positive for $t \neq 0$. Since we chose $\bar{a}_i = 0$, we can quickly compute the correspondence between the coefficients of $\bar{Q}_i(t) = \sum_j \bar{q}_{i,j} t^j$ and of $R_i(t) = \sum_j r_{i,j} t^j$:

$$r_{i,j} = (2|A_i|(2|A_i| - 1) + 4j|A_i| + j(j - 1))\bar{q}_{i,j}.$$

In particular,

$$\bar{Q}_i(0) = \bar{q}_{i,0} = \frac{r_{i,0}}{2|A_i|(2|A_i| - 1)} = \frac{R_i(0)}{2|A_i|(2|A_i| - 1)} > 0,$$

therefore $\bar{Q}_i(t)$ is everywhere positive. Since the solutions of linear equation systems move continuously when one deforms the entries of the equation system by a homotopy, this ensures that $Q_i(t)$ is everywhere positive if I_i is chosen close enough to \bar{a}_i . The positivity of $Q_i(t)$ finishes the proof. \square

3. PROJECTIONS OF DEFORMED PRODUCTS OF SIMPLE POLYTOPES

In the previous section, we saw an explicit construction of polytopes whose k -skeleton is equivalent to that of a product of simplices. In this section, we provide another construction of (k, \underline{n}) -PPSN polytopes, using Sanyal & Ziegler’s technique of “projecting deformed products of polygons” [Zie04, SZ09] and generalizing it to products of arbitrary simple polytopes. This generalized technique consists in projecting a suitable polytope that is combinatorially equivalent to a given product of simple polytopes in such a way as to preserve its complete k -skeleton. The special case of products of simplices then yields (k, \underline{n}) -PPSN polytopes.

3.1. General situation. We first discuss the general setting: given a product $P := P_1 \times \cdots \times P_r$ of simple polytopes, we construct a polytope P^\sim that is combinatorially equivalent to P and whose k -skeleton is preserved under the projection onto the first d coordinates.

3.1.1. Deformed products of simple polytopes. Let P_1, \dots, P_r be *simple* polytopes of respective dimensions n_1, \dots, n_r and facet descriptions $P_i = \{x \in \mathbb{R}^{n_i} \mid A_i x \leq b_i\}$. Here, each matrix $A_i \in \mathbb{R}^{m_i \times n_i}$ has one row for each of the m_i facets of P_i , and $b_i \in \mathbb{R}^{m_i}$. The product $P := P_1 \times \cdots \times P_r$ then has dimension $n := \sum_{i \in [r]} n_i$, and its facet description is given by the $m := \sum_{i \in [r]} m_i$ inequalities

$$\begin{pmatrix} A_1 & & \\ & \ddots & \\ & & A_r \end{pmatrix} x \leq \begin{pmatrix} b_1 \\ \vdots \\ b_r \end{pmatrix}.$$

The left hand $m \times n$ matrix, whose blank entries are all zero, shall be denoted by A . It is proved in [AZ99] that for any matrix A^\sim obtained from A by *arbitrarily* changing the zero entries above the diagonal blocks, there exists a right-hand side b^\sim such that the deformed polytope P^\sim defined by the inequality system $A^\sim x \leq b^\sim$ is combinatorially equivalent to P . The equivalence is the obvious one: it maps the facet defined by the i -th row of A to the one given by the i -th row of A^\sim , for all i . Following [SZ09], we will use this “deformed product” construction in such a way that the projection of P^\sim to the first d coordinates preserves its k -skeleton in the following sense.

3.1.2. *Preserved faces and the Projection Lemma.* For integers $n > d$, let $\pi : \mathbb{R}^n \rightarrow \mathbb{R}^d$ denote the orthogonal projection to the first d coordinates, and $\tau : \mathbb{R}^n \rightarrow \mathbb{R}^{n-d}$ denote the dual orthogonal projection to the last $n - d$ coordinates. Let P be a full-dimensional simple polytope in \mathbb{R}^n , with 0 in its interior. The following notion of preserved faces — see Figure 2 — will be used extensively at the end of this paper:

Definition 3.1 ([Zie04]). *A proper face F of a polytope P is strictly preserved under π if*

- (i) $\pi(F)$ is a face of $\pi(P)$,
- (ii) F and $\pi(F)$ are combinatorially isomorphic, and
- (iii) $\pi^{-1}(\pi(F))$ equals F .

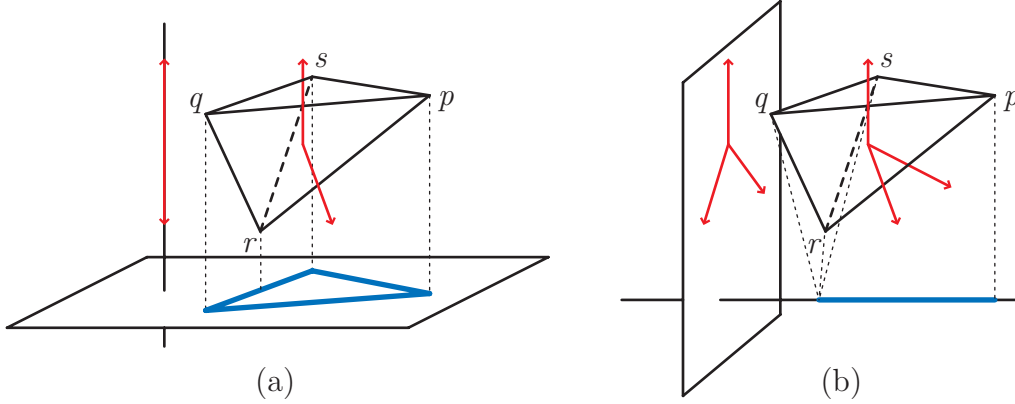

FIGURE 2. (a) Projection of a tetrahedron onto \mathbb{R}^2 : the edge pq is strictly preserved, while neither the edge qr , nor the face qrs , nor the edge qs are (because of conditions (i), (ii) and (iii) respectively). (b) Projection of a tetrahedron to \mathbb{R} : only the vertex p is strictly preserved.

The characterization of strictly preserved faces of P uses the normal vectors of the facets of P . Let F_1, \dots, F_m denote the facets of P . For all $i \in [m]$, let f_i denote the normal vector to F_i , and let $g_i := \tau(f_i)$. For any face F of P , let $\varphi(F)$ denote the set of indices of the facets of P containing F , i.e., such that $F = \bigcap_{i \in \varphi(F)} F_i$.

Lemma 3.2 (Projection Lemma [AZ99, Zie04]). *A face F of the polytope P is strictly preserved under the projection π if and only if $\{g_i \mid i \in \varphi(F)\}$ is positively spanning. \square*

3.1.3. *A first construction.* Let $t \in \{0, 1, \dots, r\}$ be maximal such that the matrices A_1, \dots, A_t are entirely contained in the first d columns of A . Let $\bar{m} := \sum_{i=1}^t m_i$ and $\bar{n} := \sum_{i=1}^t n_i$. By changing bases appropriately, we can assume that the bottom $n_i \times n_i$ block of A_i is the identity matrix for each $i \geq t+1$. In order to simplify the exposition, we also assume first that $\bar{n} = d$, i.e., that the projection on the first d coordinates separates the first t block matrices from the last $r - t$. See Figure 3a.

Let $\{g_1, \dots, g_{\bar{m}}\} \subset \mathbb{R}^{n-d}$ be a set of vectors such that $G := \{e_1, \dots, e_{n-d}\} \cup \{g_1, \dots, g_{\bar{m}}\}$ is the Gale transform of a full-dimensional simplicial neighborly polytope Q — see [Zie95, Mat02] for definition and properties of Gale duality. By elementary properties of the Gale transform, Q has $\bar{m} + n - d$ vertices, and $\dim Q = (\bar{m} + n - d) - (n - d) - 1 = \bar{m} - 1$. In particular, every subset of $\lfloor \frac{\bar{m}-1}{2} \rfloor$ vertices spans a face of Q , so every subset of $\bar{m} + n - d - \lfloor \frac{\bar{m}-1}{2} \rfloor =: \alpha$ elements of G is positively spanning.

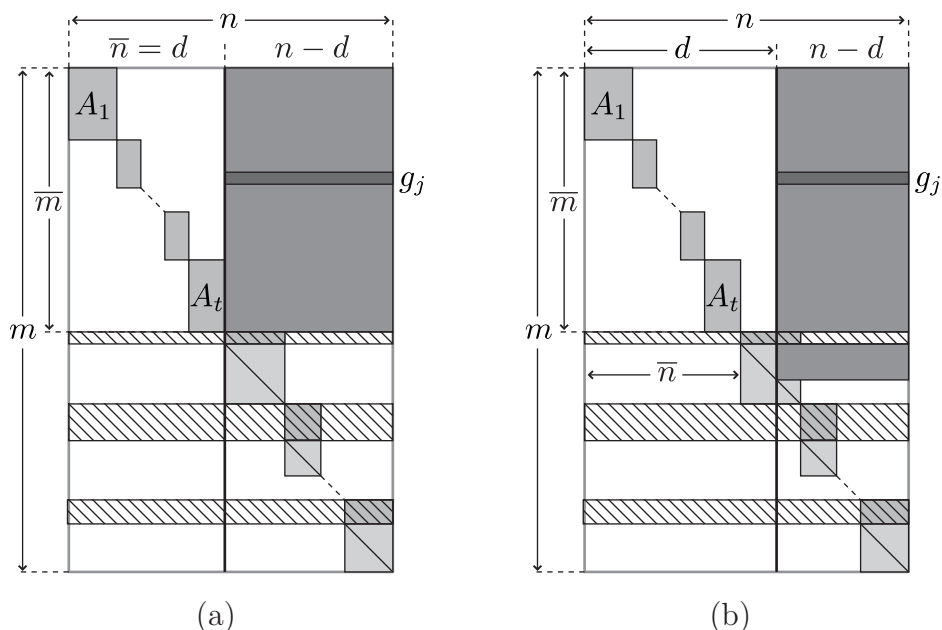

FIGURE 3. The deformed matrix A^\sim (a) when the projection does not slice any block ($\bar{n} = d$), and (b) when the block A_{t+1} is sliced ($\bar{n} < d$). Horizontal hatched boxes denote bad row vectors. The top right solid block is formed by the vectors $g_1, \dots, g_{\bar{m}}$.

We deform the matrix A into the matrix A^\sim of Figure 3a, using the vectors $g_1, \dots, g_{\bar{m}}$ to deform the top \bar{m} rows. We denote by P^\sim the corresponding deformed product. We say that a facet of P^\sim is “good” if the right part of the corresponding row of A^\sim is covered by a vector of G , and “bad” otherwise. Bad facets are hatched in Figure 3a. Observe that there are $\beta := m - \bar{m} - n + d$ bad facets in total.

Let F be a k -face of P^\sim . Since P^\sim is a simple n -dimensional polytope, F is the intersection of $n - k$ facets, among which at least $\gamma := n - k - \beta$ are good facets. If the corresponding elements of G are positively spanning, then F is strictly preserved under projection onto the first d coordinates. Since we have seen that any subset of α vectors of G is positively spanning, F will surely be preserved if $\alpha \leq \gamma$, which is equivalent to

$$k \leq n - m + \left\lfloor \frac{\bar{m} - 1}{2} \right\rfloor.$$

Thus, under this assumption, we obtain a d -dimensional polytope whose k -skeleton is combinatorially equivalent to that of $P := P_1 \times \dots \times P_r$.

3.1.4. When the projection slices a block. We now discuss the case when $\bar{n} < d$, for which the method is very similar. We consider vectors $g_1, \dots, g_{\bar{m}+d-\bar{n}}$ such that $G := \{e_1, \dots, e_{n-d}\} \cup \{g_1, \dots, g_{\bar{m}+d-\bar{n}}\}$ is the Gale dual of a neighborly polytope. We deform the matrix A into the matrix A^\sim shown in Figure 3b, using again the vectors $g_1, \dots, g_{\bar{m}}$ to deform the top \bar{m} rows and the vectors $g_{\bar{m}+1}, \dots, g_{\bar{m}+d-\bar{n}}$ to deform the top $d - \bar{n}$ rows of the $n_{t+1} \times n_{t+1}$ bottom identity submatrix of A_{t+1} . This is indeed a valid deformation since we can prescribe the

$n_{t+1} \times n_{t+1}$ bottom submatrix of A_{t+1} to be any upper triangular matrix, up to changing the basis appropriately. For the same reasons as before,

- (1) any subset of at least $\alpha := \bar{m} + n - \bar{n} - \lfloor \frac{\bar{m} + d - \bar{n} - 1}{2} \rfloor$ elements of G is positively spanning;
- (2) the number of bad facets is $\beta := m - \bar{m} - n + \bar{n}$, and thus any k -face of P^\sim is contained in at least $\gamma := n - k - \beta$ good facets.

Thus, the condition $\alpha \leq \gamma$ translates to

$$k \leq n - m + \left\lfloor \frac{\bar{m} + d - \bar{n} - 1}{2} \right\rfloor,$$

and we obtain the following proposition.

Proposition 3.3. *Let P_1, \dots, P_r be simple polytopes of respective dimension n_i , and with m_i many facets. For a fixed integer $d \leq \sum_{i=1}^r n_i$, let t be maximal such that $\sum_{i=1}^t n_i \leq d$. Then there exists a d -dimensional polytope whose k -skeleton is combinatorially equivalent to that of the product $P_1 \times \dots \times P_r$, provided*

$$0 \leq k \leq \sum_{i=1}^r (n_i - m_i) + \left\lfloor \frac{1}{2} \left(d - 1 + \sum_{i=1}^t (m_i - n_i) \right) \right\rfloor. \quad \square$$

In the next two paragraphs, we present two improvements on the bound of this proposition. Both use colorings of the graphs of the polar polytopes P_i^Δ , in order to weaken the condition $\alpha \leq \gamma$, in two different directions:

- (i) the first improvement decreases the number of required vectors in the Gale transform G , which, in turn, decreases the value of α ;
- (ii) the second one decreases the number of bad facets, and thus increases the value of γ .

3.1.5. Multiple vectors. In order to raise our bound on k , we can save vectors of G by repeating some of them several times. Namely, any two facets that have no k -face in common can share the same vector g_j . Since any two facets of a simple polytope containing a common k -face share a ridge, this condition can be expressed in terms of incidences in the graph of the polar polytope: facets not connected by an edge in this graph can use the same vector g_j . We denote the chromatic number of a graph H by $\chi(H)$. Then, each P_i with $i \leq t$ only contributes $\chi_i := \chi(\text{sk}_1 P_i^\Delta)$ different vectors in G , instead of m_i of them. Thus, we only need in total $\bar{\chi} := \sum_{i=1}^t \chi_i$ different vectors g_j . This improvement replaces \bar{m} by $\bar{\chi}$ in the formula of α , while β and γ do not change, and the condition $\alpha \leq \gamma$ is equivalent to

$$k \leq n - m + \bar{m} - \bar{\chi} + \left\lfloor \frac{\bar{\chi} - d - \bar{n} - 1}{2} \right\rfloor.$$

Thus, we obtain the following improved proposition:

Proposition 3.4. *Let P_1, \dots, P_r be simple polytopes of respective dimension n_i , and with m_i many facets. Let $\chi_i := \chi(\text{sk}_1 P_i^\Delta)$ denote the chromatic number of the graph of the polar polytope P_i^Δ . For a fixed integer $d \leq \sum_{i=1}^r n_i$, let t be maximal such that $\sum_{i=1}^t n_i \leq d$. Then there exists a d -dimensional polytope whose k -skeleton is combinatorially equivalent to that of the product $P_1 \times \dots \times P_r$, provided*

$$0 \leq k \leq \sum_{i=1}^r (n_i - m_i) + \sum_{i=1}^t (m_i - \chi_i) + \left\lfloor \frac{1}{2} \left(d - 1 + \sum_{i=1}^t (\chi_i - n_i) \right) \right\rfloor. \quad \square$$

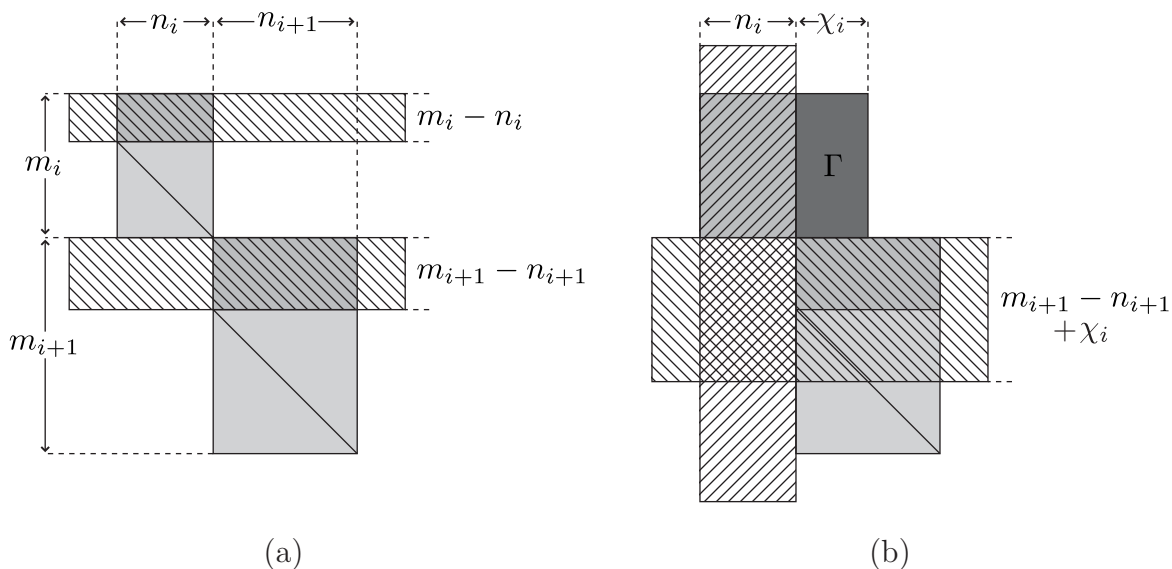

FIGURE 4. How to raise the dimension of the preserved skeleton by inserting the incidence matrix Γ of a coloring of the graph of the polar polytope P_i^Δ . Part (a) shows the situation before the insertion of Γ , and part (b) the changes that have occurred. Bad row vectors and unnecessary columns are hatched. The entries in the matrix to the left of Γ must be rescaled to retain a valid inequality description of P .

Example 3.5. Since polars of simple polytopes are simplicial, $\chi_i \geq n_i$ is an obvious lower bound for the chromatic number of the dual graph of P_i . Polytopes that attain this lower bound with equality are characterized by the property that all their 2-dimensional faces have an even number of vertices, and are called *even* polytopes.

If all P_i are even polytopes, then $\bar{n} = \bar{\chi}$, and we obtain a d -dimensional polytope with the same k -skeleton as $P_1 \times \cdots \times P_r$ provided

$$k \leq n - m + \bar{m} - \bar{n} + \left\lfloor \frac{d-1}{2} \right\rfloor.$$

In order to maximize k , we should maximize $\bar{m} - \bar{n}$, subject to the condition $\bar{n} \leq d$. For example, if all n_i are equal, this amounts to ordering the P_i by decreasing number of facets.

3.1.6. Scaling blocks. We can also apply colorings to the blocks A_i with $i \geq t + 1$, by filling in the area below G and above the diagonal blocks. To explain this, assume for the moment that $\chi_i \leq n_{i+1}$ for a certain fixed $i \geq t + 2$. Assume that the rows of A_i are colored with χ_i colors using a valid coloring $c : [m_i] \rightarrow [\chi_i]$ of the graph of the polar polytope P_i^Δ . Let Γ be the incidence matrix of c , defined by $\Gamma_{j,k} = 1$ if $c(j) = k$, and $\Gamma_{j,k} = 0$ otherwise. Thus, Γ is a matrix of size $m_i \times \chi_i$. We put this matrix to the right of A_i and above A_{i+1} as in Figure 4b, so that we append the same unit vector to each row of A_i in the same color class. Moreover, we scale all entries of the block A_i by a sufficiently small constant $\varepsilon > 0$.

In this setting, the situation is slightly different:

- (1) In the Gale dual G , we do not need the n_i basis vectors of \mathbb{R}^{n-d} hatched in Figure 4b. Let $a := \sum_{j < i} n_j$ denote the index of the last column vector of A_{i-1} and

$b := 1 + \sum_{j \leq i} n_j$ denote the index of the first column vector of A_{i+1} . We define $G := \{e_1, \dots, e_{a-d}, e_{b-d}, \dots, e_{n-d}\} \cup \{g_1, \dots, g_{\bar{m}}\}$ to be the Gale transform of a simplicial neighborly polytope Q of dimension $\bar{m} - 1 - n_i$. As before, any subset of $\alpha := \bar{m} + n - \bar{n} - n_i - \lfloor \frac{\bar{m} + d - \bar{n} - n_i - 1}{2} \rfloor$ vectors of G positively spans \mathbb{R}^{n-d} .

- (2) “Bad” facets are defined as before, except that the top $m_i - n_i$ rows of A_i are not bad anymore, but all of the first $m_{i+1} - n_{i+1} + \chi_i$ rows of A_{i+1} are now bad. Thus, the net change in the number of bad rows is $\chi_i - m_i + n_i$, so that any k -face is contained in at least $\gamma := 2n - k - m + \bar{m} - \bar{n} + m_i - n_i - \chi_i$ good rows. Up to ε -entry elements, the last $n - d$ coordinates of these rows correspond to pairwise distinct elements of G .

Applying the same reasoning as above, the k -skeleton of P^\sim is strictly preserved under projection to the first d coordinates as soon as $\alpha \leq \gamma$, which is equivalent to

$$k \leq n - m + m_i - \chi_i + \left\lfloor \frac{\bar{m} + d - \bar{n} - n_i - 1}{2} \right\rfloor.$$

Thus, we improve our bound on k provided

$$\Delta := m_i - \chi_i + \left\lfloor \frac{\bar{m} + d - \bar{n} - n_i - 1}{2} \right\rfloor - \left\lfloor \frac{\bar{m} + d - \bar{n} - 1}{2} \right\rfloor > 0.$$

For example, this difference Δ is big for polytopes whose polars have many vertices but a small chromatic number.

Finally, observe that one can apply this “scaling” improvement even if $\chi_i > n_{i+1}$ (except that it will perturb more than the two blocks A_i and A_{i+1}) and to more than one matrix A_i . Please see the example in Figure 5. In this picture, the Γ blocks are incidence matrices of colorings of the graphs of the polar polytopes. Call “diagonal entries” all entries on the diagonal of the $n_i \times n_i$ bottom submatrix of a factor A_i . A column is unnecessary (hatched in the picture) if its diagonal entry has a Γ block on the right and no Γ block above. Good rows are those covered by a vector g_j or a Γ block, together with the basis vectors whose diagonal entry has no Γ block above (bad rows are hatched in the picture).

Example 3.6. (1) If P_i is a segment, then $n_i = 1$, $m_i = 2$ and $\chi_i = 1$, so that $\Delta = 1$ if \bar{m} is even and 0 otherwise. Iterating this, if P_i is an s -dimensional cube, then $\Delta \simeq \frac{s}{2}$.

This yields *neighborly cubical polytopes* — see [JZ00, JS07].

- (2) If P_i is an even cycle, then $n_i = 2$, $m_i = 2p$ and $\chi_i = 2$, so that $\Delta = 2p - 3$. This yields *projected products of polygons* — see [Zie04, SZ09].

In general, it is difficult to give the explicit ordering of the factors and choice of deformation that will yield the largest possible value of k attainable by a concrete product $P_1 \times \dots \times P_r$ of simple polytopes, and consequently to summarize this improvement by a precise proposition as we did for our first improvement. However, this best value can clearly be found by optimizing over the finite set of all possible orderings and types of deformation. Furthermore, we can be much more explicit for products of simplices, as we detail in the next section.

3.2. Projection of deformed product of simplices. We are now ready to apply this general construction to the particular case of products of simplices. For this, we represent

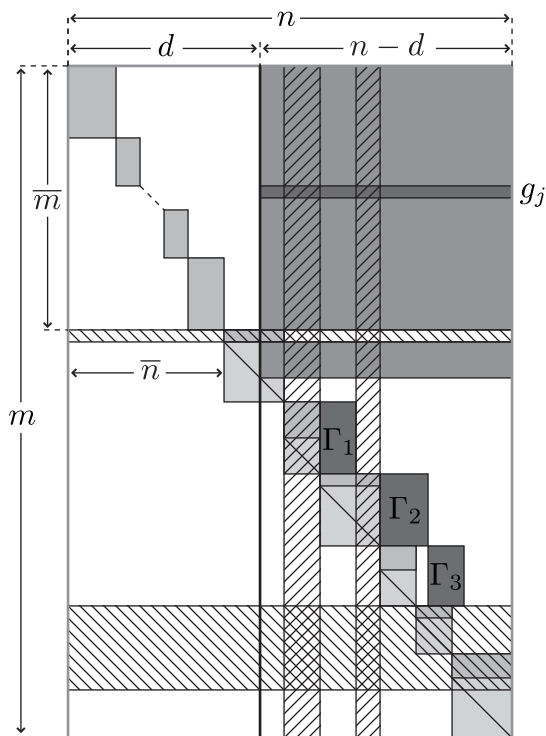

FIGURE 5. How to reduce the number of vectors in the Gale transform using various coloring matrices of polar polytopes. Situations where $\chi_i > n_{i+1}$ can be accommodated for as illustrated by the matrix Γ_2 in the picture.

the simplex Δ_{n_i} by the inequality system $A_i x \leq b_i$, where

$$A_i := \begin{pmatrix} -1 & \dots & -1 \\ 1 & & \\ & \ddots & \\ & & 1 \end{pmatrix}$$

and b_i is a suitable right-hand side. We express the results of the construction with a case distinction according to the number $s := |\{i \in [r] \mid n_i = 1\}|$ of segments in the product $\Delta_{\underline{n}}$.

Proposition 3.7. *Let $\underline{n} := (n_1, \dots, n_r)$ with $1 = n_1 = \dots = n_s < n_{s+1} \leq \dots \leq n_r$. Then*

(1) *for any $0 \leq d \leq s - 1$, there exists a d -dimensional (k, \underline{n}) -PPSN polytope provided*

$$k \leq \left\lfloor \frac{d}{2} \right\rfloor - r + s - 1.$$

(2) *for any $s \leq d \leq n$, there exists a d -dimensional (k, \underline{n}) -PPSN polytope provided*

$$k \leq \left\lfloor \frac{d + t - s}{2} \right\rfloor - r + s.$$

where $t \in \{s, \dots, r\}$ denotes the maximal integer such that $\sum_{i=1}^t n_i \leq d$.

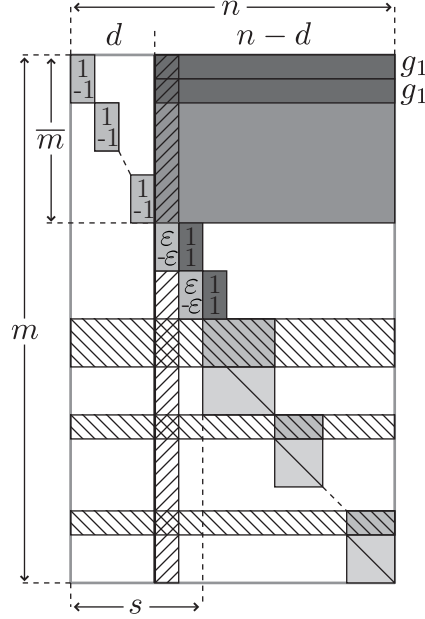

FIGURE 6. How to obtain PPSN polytopes from a deformed product construction, when the number s of segment factors exceeds the target dimension d of the projection.

Proof of (1). This is a special case of the results obtainable with the methods of Section 3.1. The best construction is obtained using the matrix in Figure 6, from which we read off that

- (1) any subset of at least $\alpha := n - \lfloor \frac{d}{2} \rfloor$ vectors in G is positively spanning; and
- (2) the number of bad facets is $\beta := r - s + 1$, and therefore any k -face of P^\sim is contained in at least $\gamma := n - k - r + s - 1$ good facets.

From this, the claim follows. \square

Proof of (2). Consider the deformed product of Figure 7a. Using similar calculations as before, we deduce that

- (1) any subset of at least $\alpha := t - s + n - \lfloor \frac{d+t-s-1}{2} \rfloor$ vectors in G is positively spanning; and
- (2) the number of bad facets is $\beta := r - t$, and therefore any k -face of P^\sim is contained in at least $\gamma := n - k - r + t$ good facets.

This yields a bound of

$$k \leq \left\lfloor \frac{d+t-s-1}{2} \right\rfloor - r + s.$$

We optimize the final ‘ -1 ’ away by suitably deforming the matrix A_{t+1} as in Figure 7b. This amounts to adding one more vector g_\star to the Gale diagram, so that the first row of A_{t+1} ceases to be a bad facet. This deformation is valid because:

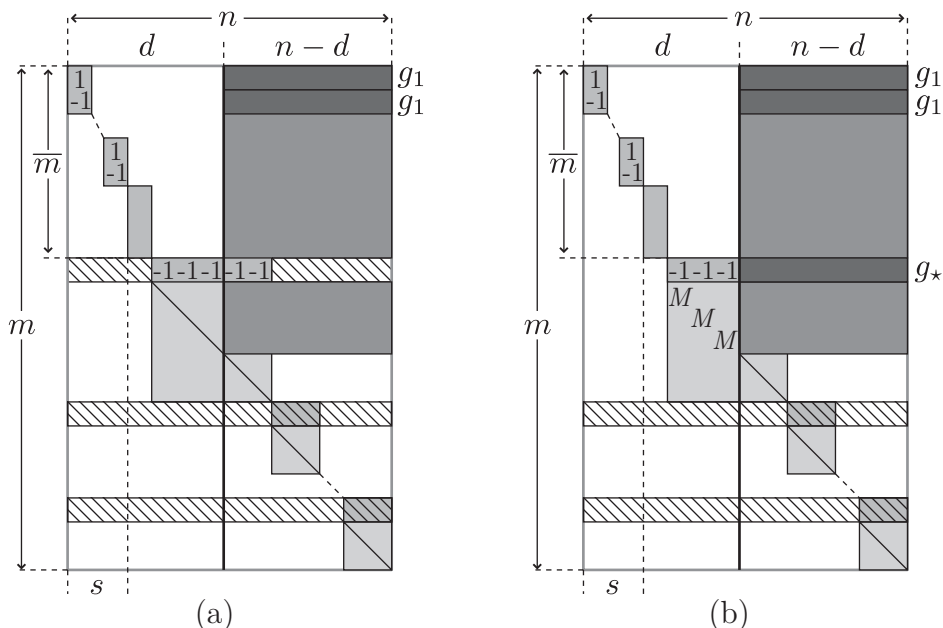

FIGURE 7. Obtaining PPSN polytopes from a deformed product construction, when few of the factors are segments. Part (a) shows the technique used so far, and part (b) an additional optimization that exchanges a bad facet for a new vector in the Gale transform.

- (1) the matrix

$$\begin{pmatrix} -1 & \dots & -1 & \star & \dots & \star \\ M & & & & & \\ & \ddots & & & & \\ & & M & & & \\ & & & 1 & & \\ & & & & \ddots & \\ & & & & & 1 \end{pmatrix}$$

still defines a simplex, as long as the ‘ \star ’ entries are negative and $M \gg 0$ is chosen to be sufficiently large;

- (2) we can in fact choose the new vector g_\star to have only negative entries, by imposing an additional restriction on the Gale diagram $G = \{e_1, \dots, e_{n-d}, g_1, \dots, g_{d+t}, g_\star\}$ of Q . Namely, we require that the vertices of the $(d+t)$ -dimensional simplicial polytope Q that correspond to the Gale vectors g_1, \dots, g_{d+t} lie on a facet. This forces the remaining vectors $e_1, \dots, e_{n-d}, g_\star$ to be positively spanning, so that g_\star has only negative entries. \square

Finally, we reformulate Proposition 3.7 to express, in terms of k and $\underline{n} := (n_1, \dots, n_r)$, what dimensions a (k, \underline{n}) -PPSN polytope can have. This yields upper bounds on $\delta_{pr}(k, \underline{n})$.

Theorem 3.8. For any $k \geq 0$ and $\underline{n} := (n_1, \dots, n_r)$ with $1 = n_1 = \dots = n_s < n_{s+1} \leq \dots \leq n_r$,

$$\delta_{pr}(k, \underline{n}) \leq \begin{cases} 2(k+r) - s - t & \text{if } 3s \leq 2k + 2r, \\ 2(k+r-s) + 1 & \text{if } 3s = 2k + 2r + 1, \\ 2(k+r-s+1) & \text{if } 3s \geq 2k + 2r + 2, \end{cases}$$

where $t \in \{s, \dots, r\}$ is maximal such that

$$3s + \sum_{i=s+1}^t (n_i + 1) \leq 2k + 2r.$$

Proof. Apply part (1) of Proposition 3.7 when $3s \geq 2k + 2r + 2$ and part (2) otherwise. \square

Remark 3.9. When all the n_i 's are large compared to k , the dimension of the (k, \underline{n}) -PPSN polytope provided by this theorem is bigger than the dimension $2k + r + 1$ of the (k, \underline{n}) -PPSN polytope obtained by the Minkowski sum of cyclic polytopes of Theorem 2.6. However, if we have many segments (neighborly cubical polytopes), or more generally if many n_i 's are small compared to k , this construction provides our best examples of PPSN polytopes.

4. TOPOLOGICAL OBSTRUCTIONS

In this section, we give lower bounds on the minimal dimension $\delta_{pr}(k, \underline{n})$ of a (k, \underline{n}) -PPSN polytope, applying and extending a method developed by Sanyal [San09] to bound the number of vertices of Minkowski sums of polytopes. This method provides lower bounds on the target dimension of any linear projection that preserves a given set of faces of a polytope. It uses Gale duality to associate a certain simplicial complex \mathcal{K} to the set of faces that are preserved under the projection. Then lower bounds on the embeddability dimension of \mathcal{K} transfer to lower bounds on the target dimension of the projection. In turn, the embeddability dimension is bounded via colorings of the Kneser graph of the system of minimal non-faces of \mathcal{K} , using Sarkaria's Embeddability Theorem.

For the convenience of the reader, we first quickly recall this embeddability criterion. We then provide a brief overview of Sanyal's method before applying it to obtain lower bounds on the dimension of (k, \underline{n}) -PPSN polytopes. As mentioned in the introduction, these bounds match the upper bounds obtained from our different constructions for a wide range of parameters, and thus give the exact value of the minimal dimension of a PPSN polytope.

4.1. Sarkaria's embeddability criterion.

4.1.1. *Kneser graphs.* Recall that a k -coloring of a graph $G = (V, E)$ is a map $c : V \rightarrow [k]$ such that $c(u) \neq c(v)$ for $(u, v) \in E$. As usual, let $\chi(G)$ denote the *chromatic number* of G (i.e., the minimal k such that G admits a k -coloring). We are interested in the chromatic number of so-called Kneser graphs.

Let \mathcal{Z} be a subset of the power set $2^{[n]}$ of $[n]$. The *Kneser graph* on \mathcal{Z} , denoted $\text{KG}(\mathcal{Z})$, is the graph with vertex set \mathcal{Z} , where $X, Y \in \mathcal{Z}$ are adjacent if and only if $X \cap Y = \emptyset$:

$$\text{KG}(\mathcal{Z}) := (\mathcal{Z}, \{(X, Y) \in \mathcal{Z}^2 \mid X \cap Y = \emptyset\}).$$

Let $\text{KG}_n^k := \text{KG}(\binom{[n]}{k})$ denote the Kneser graph on the set of subsets of $[n]$ of size k . For example, the graph KG_n^1 is the complete graph K_n (of chromatic number n) and the graph KG_5^2 is the Petersen graph (of chromatic number 3).

Remark 4.1. (1) If $n \leq 2k - 1$, then any two k -subsets of $[n]$ intersect and the Kneser graph KG_n^k is independent (*i.e.*, it has no edge). Thus its chromatic number is $\chi(\text{KG}_n^k) = 1$.

(2) If $n \geq 2k - 1$, then $\chi(\text{KG}_n^k) \leq n - 2k + 2$. Indeed, the map $c : \binom{[n]}{k} \rightarrow [n - 2k + 2]$ defined by $c(F) := \min(F \cup \{n - 2k + 2\})$ is a $(n - 2k + 2)$ -coloring of KG_n^k .

In fact, it turns out that this upper bound is the exact chromatic number of the Kneser graph: $\chi(\text{KG}_n^k) = \max\{1, n - 2k + 2\}$. This result was conjectured by Kneser [Kne55] in 1955, and proved by Lovász [Lov78] in 1978 applying the Borsuk-Ulam Theorem — see [Mat03] for more details. However, we will only need the upper bound for the topological obstruction.

4.1.2. *Sarkaria's Theorem.* Our lower bounds on the dimension of (k, \underline{n}) -PPSN polytopes rely on lower bounds for the dimension in which certain simplicial complexes can be embedded. Among other possible methods [Mat03], we use Sarkaria's Coloring and Embedding Theorem.

We associate to any simplicial complex \mathcal{K} the set system \mathcal{Z} of *minimal non-faces* of \mathcal{K} , that is, the inclusion-minimal sets of $2^{V(\mathcal{K})} \setminus \mathcal{K}$. For example, the complex of minimal non-faces of the k -skeleton of the n -dimensional simplex is $\binom{[n+1]}{k+2}$. Sarkaria's Theorem provides a lower bound on the dimension into which \mathcal{K} can be embedded, in terms of the chromatic number of the Kneser graph of \mathcal{Z} .

Theorem 4.2 (Sarkaria's Theorem). *Let \mathcal{K} be a simplicial complex embeddable in \mathbb{R}^d , \mathcal{Z} be the system of minimal non-faces of \mathcal{K} , and $\text{KG}(\mathcal{Z})$ be the Kneser graph on \mathcal{Z} . Then*

$$d \geq |V(\mathcal{K})| - \chi(\text{KG}(\mathcal{Z})) - 1.$$

In other words, we get large lower bounds on the possible embedding dimension of \mathcal{K} when the Kneser graph of minimal non-faces of \mathcal{K} has small chromatic number. We refer to the excellent treatment in [Mat03] for further details.

4.2. **Sanyal's topological obstruction method.** For given integers $n > d$, we consider the orthogonal projection $\pi : \mathbb{R}^n \rightarrow \mathbb{R}^d$ to the first d coordinates, and its dual projection $\tau : \mathbb{R}^n \rightarrow \mathbb{R}^{n-d}$ to the last $n - d$ coordinates. Let P be a full-dimensional simple polytope in \mathbb{R}^n , with 0 in its interior, and assume that its vertices are strictly preserved under π . Let F_1, \dots, F_m denote the facets of P . For all $i \in [m]$, let f_i denote the normal vector to F_i , and let $g_i := \tau(f_i)$. For any face F of P , let $\varphi(F)$ denote the set of indices of the facets of P containing F , *i.e.*, such that $F = \bigcap_{i \in \varphi(F)} F_i$.

Lemma 4.3 (Sanyal [San09]). *The vector configuration $G := \{g_i \mid i \in [m]\} \subset \mathbb{R}^{n-d}$ is the Gale transform of the vertex set $\{a_i \mid i \in [m]\}$ of a (full-dimensional) polytope Q of $\mathbb{R}^{m-n+d-1}$. Up to a slight perturbation of the facets of P , we can even assume Q to be simplicial.*

We will refer to the polytope Q as *Sanyal's projection polytope*. The faces of this polytope capture the key notion of strictly preserved faces of P — remember Definition 3.1. Indeed, the Projection Lemma 3.2 ensures that for any face F of P that is strictly preserved by the projection π , the set $\{g_i \mid i \in \varphi(F)\}$ is positively spanning. By Gale duality, this implies that the set of vertices $\{a_i \mid i \in [m] \setminus \varphi(F)\}$ forms a face of Q .

Example 4.4. Let P be a triangular prism in 3-space that projects to a hexagon as in Figure 8a, so that $n = 3$, $d = 2$ and $m = 5$. The vector configuration $G \subset \mathbb{R}^1$ obtained by projecting P 's normal vectors consists of three vectors pointing up and two pointing down, so that Sanyal's projection polytope Q is a bipyramid over a triangle. An edge $F_i \cap F_j$ of P

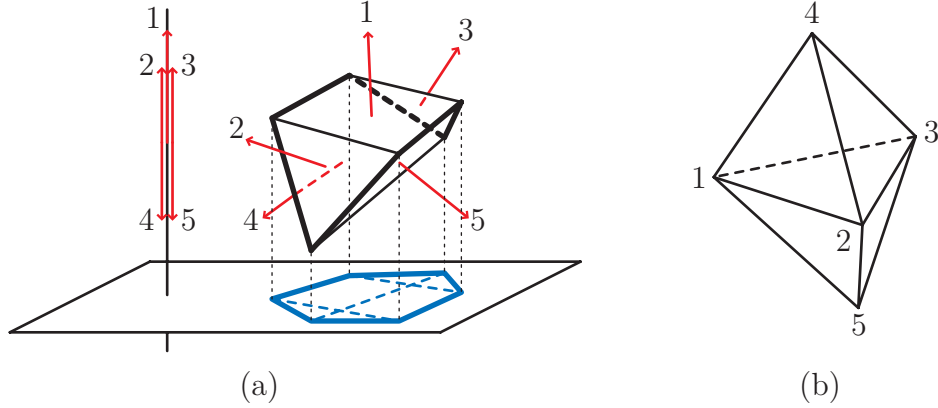

FIGURE 8. (a) Projection of a triangular prism and (b) its associated projection polytope Q . The six faces of Q corresponding to the six edges of P preserved under projection (in bold) make up the entire boundary complex of Q .

that is preserved under projection corresponds to the face $[5] \setminus \{i, j\}$ of Q . Notice that the six faces of Q corresponding to the six edges of P that are preserved under projection (in bold in Figure 8a) make up the entire boundary complex of the bipyramid Q .

Let \mathcal{F} be a collection of faces of P that are strictly preserved under π . Define \mathcal{K} to be the simplicial complex induced by $\{[m] \setminus \varphi(F) \mid F \in \mathcal{F}\}$.

Remark 4.5. Notice that not all non-empty faces of \mathcal{K} correspond to non-empty faces in \mathcal{F} : in Example 4.4, if \mathcal{F} consists of all strictly preserved edges, then \mathcal{K} is the entire boundary complex of Sanyal's projection polytope Q , so that it contains the edge $\{2, 3\}$. But then the complementary intersection of facets, $F_1 \cap F_4 \cap F_5$, does not correspond to any non-empty face of P .

Since the set of vertices $\{a_i \mid i \in [m] \setminus \varphi(F)\}$ forms a face of Q for any face $F \in \mathcal{F}$, and since Q is simplicial, \mathcal{K} is a subcomplex of the face complex of $Q \subset \mathbb{R}^{m-n+d-1}$. In particular, when \mathcal{K} is not the entire boundary complex of Q , it embeds into $\mathbb{R}^{m-n+d-2}$ by stereographic projection (otherwise, it only embeds into $\mathbb{R}^{m-n+d-1}$, as happens in Example 4.4).

Thus, given the simple polytope $P \subset \mathbb{R}^n$ and a set \mathcal{F} of faces of P that we want to preserve under projection, the study of the embeddability of the corresponding abstract simplicial complex \mathcal{K} provides lower bounds on the dimension d in which we can project P . We proceed in the following way:

- (1) we first choose our subset \mathcal{F} of strictly preserved faces to be simple enough to understand and large enough to provide an obstruction;
- (2) we then understand the system \mathcal{Z} of minimal non-faces of the simplicial complex \mathcal{K} ;
- (3) finally, we find a suitable coloring of the Kneser graph on \mathcal{Z} and apply Sarkaria's Theorem 4.2 to bound the dimension in which \mathcal{K} can be embedded: a t -coloring of $\text{KG}(\mathcal{Z})$ ensures that \mathcal{K} is not embeddable into $|V(\mathcal{K})| - t - 2 = m - t - 2$, which by the previous paragraph bounds the dimension d from below as follows:

Theorem 4.6 (Sanyal [San09]). *Let P be a simple polytope in \mathbb{R}^n whose facets are in general position, and let $\pi : \mathbb{R}^n \rightarrow \mathbb{R}^d$ be a projection. Let \mathcal{F} be a subset of the set of all strictly*

preserved faces of P under π , let \mathcal{K} be the simplicial complex induced by $\{[m] \setminus \varphi(F) \mid F \in \mathcal{F}\}$, and let \mathcal{Z} be its system of minimal non-faces. If the Kneser graph $\text{KG}(\mathcal{Z})$ is t -colorable, then

- (1) if \mathcal{K} is not the entire boundary complex of the Sanyal polytope Q , then $d \geq n - t + 1$;
- (2) otherwise, $d \geq n - t$. □

In the remainder of this section, we apply Sanyal’s topological obstruction to our problem. The hope was initially to extend it to bound the target dimension of a projection preserving the k -skeleton of an arbitrary product of simple polytopes. However, the combinatorics involved to deal with this general question turn out to be too complicated, and so we restrict our attention to products of simplices. This yields bounds on the minimal dimension $\delta_{pr}(k, \underline{n})$ of a (k, \underline{n}) -PPSN polytope.

4.3. Preserving the k -skeleton of a product of simplices. In this section, we understand the abstract simplicial complex \mathcal{K} corresponding to our problem, and describe its system of minimal non-faces.

The facets of $\Delta_{\underline{n}}$ are exactly the products

$$\psi_{i,j} := \Delta_{n_1} \times \cdots \times \Delta_{n_{i-1}} \times (\Delta_{n_i} \setminus \{j\}) \times \Delta_{n_{i+1}} \times \cdots \times \Delta_{n_r},$$

for $i \in [r]$ and $j \in [n_i + 1]$. We identify the facet $\psi_{i,j}$ with the element $j \in [n_i + 1]$ of the disjoint union $[n_1 + 1] \uplus [n_2 + 1] \uplus \cdots \uplus [n_r + 1]$.

Let $F := F_1 \times \cdots \times F_r$ be a k -face of $\Delta_{\underline{n}}$. Then F is contained in a facet $\psi_{i,j}$ of $\Delta_{\underline{n}}$ if and only if $j \notin F_i$. Thus, the set of facets of $\Delta_{\underline{n}}$ that do not contain F is exactly $F_1 \uplus \cdots \uplus F_r$. Consequently, if we want to preserve the k -skeleton of $\Delta_{\underline{n}}$, then the abstract simplicial complex \mathcal{K} we are interested in is induced by

$$(3) \quad \left\{ F_1 \uplus \cdots \uplus F_r \mid \emptyset \neq F_i \subset [n_i + 1] \text{ for all } i \in [r], \text{ and } \sum_{i \in [r]} (|F_i| - 1) = k \right\}.$$

Remark 4.7. In contrast to the general case, when we want to preserve the *complete* k -skeleton of a product of simplices, the complex \mathcal{K} cannot be the entire boundary complex of the Sanyal polytope Q . As a consequence, the better lower bound from part (1) of Sanyal’s Theorem 4.6 always holds, and we always use it from now on without further notice.

To prove that \mathcal{K} cannot cover the entire boundary complex of Q , observe that

$$\dim Q = m - n + d - 1 = \sum (n_i + 1) - \sum n_i + d - 1 = r + d - 1,$$

while $\dim \mathcal{K} = r + k - 1$ by (3). A necessary condition for \mathcal{K} to be the entire boundary complex of Q is that $\dim \mathcal{K} = \dim Q - 1$, which translates to $d = k + 1$. Now suppose that the entire k -skeleton of $\Delta_{\underline{n}}$ is preserved under projection to dimension $k + 1$. Then the projections of those k -faces are facets of $\pi(\Delta_{\underline{n}})$. Since any ridge of the projected polytope is contained in exactly two facets, and the *entire* k -skeleton of $\Delta_{\underline{n}}$ is preserved, we know that any $(k - 1)$ -face of $\Delta_{\underline{n}}$ is also contained in exactly two k -faces. But this can only happen if $k = n - 1$, which means $n = d$.

Recall from Example 4.4 that \mathcal{K} can be the entire boundary complex of Q if we do not preserve *all* k -faces of $\Delta_{\underline{n}}$.

The following lemma gives a description of the minimal non-faces of \mathcal{K} :

Lemma 4.8. *The system of minimal non-faces of \mathcal{K} is*

$$\mathcal{Z} := \left\{ G_1 \uplus \cdots \uplus G_r \mid |G_i| \neq 1 \text{ for all } i \in [r], \text{ and } \sum_{i \mid G_i \neq \emptyset} (|G_i| - 1) = k + 1 \right\}.$$

Proof. A subset $G := G_1 \uplus \cdots \uplus G_r$ of $[n_1 + 1] \uplus [n_2 + 1] \uplus \cdots \uplus [n_r + 1]$ is a face of \mathcal{K} when it can be extended to a subset $F_1 \uplus \cdots \uplus F_r$ with $\sum (|F_i| - 1) = k$ and $\emptyset \neq F_i \subset [n_i + 1]$ for all $i \in [r]$, that is, when

$$k \geq \left| \{i \in [r] \mid G_i = \emptyset\} \right| + \sum_{i \in [r]} (|G_i| - 1) = \sum_{i \mid G_i \neq \emptyset} (|G_i| - 1).$$

Thus, G is a non-face if and only if

$$\sum_{i \mid G_i \neq \emptyset} (|G_i| - 1) \geq k + 1.$$

If $\sum_{i \mid G_i \neq \emptyset} (|G_i| - 1) > k + 1$, then removing any element provides a smaller non-face. If there is an i such that $|G_i| = 1$, then removing the unique element of G_i provides a smaller non-face. Thus, if G is a minimal non-face, then $\sum_{i \mid G_i \neq \emptyset} (|G_i| - 1) = k + 1$, and $|G_i| \neq 1$ for all $i \in [r]$.

Reciprocally, if G is a non-minimal non-face, then it is possible to remove one element keeping a non-face. Let $i \in [r]$ be such that we can remove one element from G_i , keeping a non-face. Then, either $|G_i| = 1$, or

$$\sum_{j \mid G_j \neq \emptyset} (|G_j| - 1) \geq 1 + (|G_i| - 2) + \sum_{j \neq i \mid G_j \neq \emptyset} (|G_j| - 1) \geq k + 2,$$

since we keep a non-face. □

4.4. Colorings of $\text{KG}(\mathcal{Z})$. Our next goal is to provide a suitable coloring of the Kneser graph on the system \mathcal{Z} of minimal non-faces of \mathcal{K} . Let $S := \{i \in [r] \mid n_i = 1\}$ denote the set of indices corresponding to the segments, and $R := \{i \in [r] \mid n_i \geq 2\}$ the set of indices corresponding to the non-segments in the product $\Delta_{\underline{n}}$. We first provide a coloring for two extremal situations.

Theorem 4.9 (Topological obstruction for low-dimensional skeleta). *If $k \leq \sum_{i \in R} \lfloor \frac{n_i - 2}{2} \rfloor$, then the dimension of any (k, \underline{n}) -PPSN polytope cannot be smaller than $2k + |R| + 1$:*

$$\delta_{pr}(k, \underline{n}) \geq 2k + |R| + 1.$$

Proof. Let $k_1, \dots, k_r \in \mathbb{N}$ be such that

$$\sum_{i \in [r]} k_i = k \quad \text{and} \quad \begin{cases} k_i = 0 & \text{for } i \in S; \\ 0 \leq k_i \leq \frac{n_i - 2}{2} & \text{for } i \in R. \end{cases}$$

Observe that

- (1) such a tuple exists since $k \leq \sum_{i \in R} \lfloor \frac{n_i - 2}{2} \rfloor$, and
- (2) for any minimal non-face $G := G_1 \uplus \cdots \uplus G_r$ of \mathcal{Z} , there exists $i \in [r]$ such that $|G_i| \geq k_i + 2$. Indeed, if $|G_i| \leq k_i + 1$ for all $i \in [r]$, then

$$k + 1 = \sum_{i \mid G_i \neq \emptyset} (|G_i| - 1) \leq \sum_{i \mid G_i \neq \emptyset} k_i \leq \sum_{i \in [r]} k_i = k,$$

which is impossible.

For all $i \in [r]$, we fix a proper coloring $\gamma_i : \binom{[n_i+1]}{[k_i+2]} \rightarrow [\chi_i]$ of the Kneser graph $\text{KG}_{n_i+1}^{k_i+2}$, with $\chi_i = 1$ if $i \in S$ and $\chi_i = n_i - 2k_i - 1$ if $i \in R$ — see Section 4.1.1. We define a coloring $\gamma : \mathcal{Z} \rightarrow [\chi_1] \uplus \cdots \uplus [\chi_r]$ of the Kneser graph on \mathcal{Z} as follows. Let $G := G_1 \uplus \cdots \uplus G_r$ be a given minimal non-face of \mathcal{Z} . We arbitrarily choose an $i \in [r]$ such that $|G_i| \geq k_i + 2$, and a subset g of G_i with $k_i + 2$ elements. We color G with the color of g in $\text{KG}_{n_i+1}^{k_i+2}$, that is, we define $\gamma(G) := \gamma_i(g)$.

The coloring γ is a proper coloring of the Kneser graph $\text{KG}(\mathcal{Z})$. Indeed, let $G := G_1 \uplus \cdots \uplus G_r$ and $H := H_1 \uplus \cdots \uplus H_r$ be two minimal non-faces of \mathcal{Z} related by an edge in $\text{KG}(\mathcal{Z})$, which means that they do not intersect. Let $i \in [r]$ and $g \subset G_i$ be such that we have colored G with $\gamma_i(g)$, and similarly $j \in [r]$ and $h \subset G_j$ be such that we have colored H with $\gamma_j(h)$. Since the color sets of $\gamma_1, \dots, \gamma_r$ are disjoint, the non-faces G and H can receive the same color $\gamma_i(G) = \gamma_j(H)$ only if $i = j$ and g and h are not related by an edge in $\text{KG}_{n_i+1}^{k_i+2}$, which implies that $g \cap h \neq \emptyset$. But this cannot happen, because $g \cap h \subset G_i \cap H_i$, which is empty by assumption. Thus, G and H get different colors.

This provides a proper coloring of $\text{KG}(\mathcal{Z})$ with $\sum \chi_i$ colors. By Theorem 4.6 and Remark 4.7, we know that the dimension d of the projection is at least

$$\sum_{i \in [r]} n_i - \sum_{i \in [r]} \chi_i + 1 = 2k + |R| + 1. \quad \square$$

Theorem 4.10 (Topological obstruction for high-dimensional skeleta). *If $k \geq \lfloor \frac{1}{2} \sum_i n_i \rfloor$, then any (k, \underline{n}) -PPSN polytope is combinatorially equivalent to $\Delta_{\underline{n}}$:*

$$\delta_{pr}(k, \underline{n}) \geq \sum n_i.$$

Proof. Let $G := G_1 \uplus \cdots \uplus G_r$ and $H := H_1 \uplus \cdots \uplus H_r$ be two minimal non-faces of \mathcal{Z} . Let $A := \{i \in [r] \mid G_i \neq \emptyset \text{ or } H_i \neq \emptyset\}$. Then

$$\begin{aligned} \sum_{i \in A} (|G_i| + |H_i|) &\geq \sum_{G_i \neq \emptyset} (|G_i| - 1) + \sum_{H_i \neq \emptyset} (|H_i| - 1) + |A| \\ &= 2k + 2 + |A| > \sum_{i \in [r]} n_i + |A| \geq \sum_{i \in A} (n_i + 1). \end{aligned}$$

Thus, there exists $i \in A$ such that $|G_i| + |H_i| > n_i + 1$, which implies that $G_i \cap H_i \neq \emptyset$, and proves that $G \cap H \neq \emptyset$.

Consequently, the Kneser graph $\text{KG}(\mathcal{Z})$ is independent (and we can color it with only one color). We obtain that the dimension d of the projection is at least $\sum n_i$. In other words, in this extremal case, there is no better (k, \underline{n}) -PSN polytope than the product $\Delta_{\underline{n}}$ itself. \square

Remark 4.11. Theorem 4.10 can sometimes be strengthened a little: If $k = \frac{1}{2} \sum n_i - 1$, and $k + 1$ is not representable as a sum of a subset of $\{n_1, \dots, n_r\}$, then $\delta_{pr}(k, \underline{n}) = \sum n_i$.

Proof. As in the previous theorem, we prove that the Kneser graph $\text{KG}(\mathcal{Z})$ is independent. Indeed, assume that $G := G_1 \uplus \cdots \uplus G_r$ and $H := H_1 \uplus \cdots \uplus H_r$ are two minimal non-faces of \mathcal{Z} related by an edge in $\text{KG}(\mathcal{Z})$. Then, $G \cap H$ is empty, which implies that for all $i \in [r]$,

$$(4) \quad |G_i| + |H_i| \leq n_i + 1.$$

Let $U := \{i \mid G_i \neq \emptyset\}$ and $V := \{i \mid H_i \neq \emptyset\}$. Then,

$$\begin{aligned} \sum_{i \in U \cup V} (|G_i| + |H_i|) &= \sum_{i \in U} (|G_i| - 1) + \sum_{i \in V} (|H_i| - 1) + |U| + |V| = 2k + 2 + |U| + |V| \\ &= \sum_{i \in [r]} n_i + |U| + |V| \stackrel{(\star)}{\geq} \sum_{i \in U \cup V} n_i + |U \cup V| = \sum_{i \in U \cup V} (n_i + 1). \end{aligned}$$

Summing (4) over $i \in U \cup V$ implies that both the inequality (\star) and (4) for $i \in U \cup V$ are in fact equalities. The tightness of (\star) implies furthermore that $|U| + |V| = |U \cup V|$, so that $U \cap V = \emptyset$; in other words, H_i is empty whenever G_i is not. The equality in (4) then asserts that $|G_i| = n_i + 1$ for all $i \in U$, and therefore

$$k + 1 = \sum_{i \in U} (|G_i| - 1) = \sum_{i \in U} n_i$$

is representable as a sum of a subset of the n_i , which contradicts the assumption. \square

Finally, to fill the gap in the ranges of k covered by Theorems 4.9 and 4.10, we merge both coloring ideas as follows.

We partition $[r] = A \uplus B$ and choose $k_i \geq 0$ for all $i \in A$ and $k_B \geq 0$ such that

$$(5) \quad \left(\sum_{i \in A} k_i \right) + k_B \leq k.$$

We will determine the best choices for A , B , k_B and the k_i 's later. Let $n_B := \sum_{i \in B} n_i$. Color the Kneser graphs $\text{KG}_{n_i+1}^{k_i+2}$ for $i \in A$ and $\text{KG}_{n_B}^{k_B+1}$ with pairwise disjoint color sets with

$$\chi_i := \begin{cases} n_i - 2k_i - 1 & \text{if } 2k_i \leq n_i - 2, \\ 1 & \text{if } 2k_i \geq n_i - 2, \end{cases}$$

and

$$\chi_B := \begin{cases} 0 & \text{if } n_B = 0, \\ n_B - 2k_B & \text{if } 2k_B \leq n_B - 1, \\ 1 & \text{if } 2k_B \geq n_B - 1, \end{cases}$$

colors respectively.

Observe now that for all minimal non-faces $G := G_1 \uplus \dots \uplus G_r$, either there is an $i \in A$ such that $|G_i| \geq k_i + 2$, or $\sum_{i \in B \mid G_i \neq \emptyset} (|G_i| - 1) \geq k_B + 1$. Indeed, otherwise

$$k + 1 = \sum_{i \mid G_i \neq \emptyset} (|G_i| - 1) \leq \left(\sum_{i \in A} k_i \right) + k_B \leq k.$$

This allows us to define a coloring of $\text{KG}(\mathcal{Z})$ in the following way. For each minimal non-face $G := G_1 \uplus \dots \uplus G_r$, we arbitrarily choose one of the following strategies:

- (1) If we can find an $i \in A$ such that $|G_i| \geq k_i + 2$, we choose an arbitrary subset g of G_i with $k_i + 2$ elements, and color G with the color of g in $\text{KG}_{n_i+1}^{k_i+2}$.
- (2) Otherwise, $\sum_{i \in B \mid G_i \neq \emptyset} (|G_i| - 1) \geq k_B + 1$, and we choose an arbitrary subset g of

$$\bigsqcup_{i \in B} (G_i \setminus \{n_i + 1\}) \subset \bigsqcup_{i \in B} [n_i]$$

with $k_B + 1$ elements and color G with the color of g in $\text{KG}_{n_B}^{k_B+1}$.

By exactly the same argument as in the proof of Theorem 4.9, one can verify that this provides a valid coloring of the Kneser graph $\text{KG}(\mathcal{Z})$ with

$$\chi := \chi(A, B, \underline{k}_i, k_B) := \sum_{i \in A} \chi_i + \chi_B$$

many colors. Therefore Sanyal's Theorem 4.6 and Remark 4.7 yield the following lower bound on the dimension d of any (k, \underline{n}) -PPSN polytope:

$$d \geq d_k := d_k(A, B, \underline{k}_i, k_B) := \sum_i n_i + 1 - \chi \geq \delta_{pr}(k, \underline{n}).$$

It remains to choose parameters A , B , and $\{k_i \mid i \in A\}$ and k_B that maximize this bound. We proceed algorithmically, by first fixing A and B , and choosing the k_i 's and k_B to maximize the bound on the dimension d_k . For this, we first start with $k_i = 0$ for all i and $k_B = 0$, and observe the variation of d_k as we increase individual k_i 's or k_B . By (5), we are only allowed a total of k such increases. During this process, we will always maintain the conditions $2k_i \leq n_i - 1$ for all $i \in A_i$ and $2k_B \leq n_B$ (which makes sense by the formulas for χ_i and χ_B).

We start with $k_i = 0$ for all i and $k_B = 0$. Then

$$\begin{aligned} \chi(A, B, \underline{0}, 0) &= \sum_{i \in A} (n_i - 1) + |S \cap A| + n_B \\ &= \sum_{i \in A} n_i - |A| + |S \cap A| + \sum_{i \in B} n_i = \sum_{i \in [r]} n_i - r + |B \cup S|, \end{aligned}$$

and

$$d_k(A, B, \underline{0}, 0) = 1 + r - |B \cup S|,$$

where $S := \{i \in [r] \mid n_i = 1\}$ denotes the set of segments.

We now study the variation of d_k as we increase each of the k_i 's and k_B by one. For $i \in A$, increasing k_i by one decreases χ_i by

$$\begin{cases} 2, & \text{if } 2k_i \leq n_i - 4, \\ 1, & \text{if } 2k_i = n_i - 3, \\ 0, & \text{if } 2k_i \geq n_i - 2, \end{cases}$$

and hence increases d_k by the same amount. Observe in particular that d_k remains invariant if we increase k_i for some segment $i \in S$ (because $n_i = 1$ for segments). Thus, it makes sense to choose B to contain all segments. Similarly, increasing k_B by one decreases χ_B by

$$\begin{cases} 2, & \text{if } 2k_B \leq n_B - 3, \\ 1, & \text{if } 2k_B = n_B - 2, \\ 0, & \text{if } 2k_B \geq n_B - 1, \end{cases}$$

and increases d_k by the same amount.

Recall that we are allowed at most k increases of k_i 's or k_B by (5). Heuristically, it seems reasonable to first increase the k_i 's or k_B that increase d_k by two, and then these that increase d_k by one. Hence we get a case distinction on k , which also depends on A and B :

Theorem 4.12 (Topological obstruction, general case). *Let $k \geq 0$ and $\underline{n} := (n_1, \dots, n_r)$ with $r \geq 1$ and $n_i \geq 1$ for all i . Let $[r] = A \uplus B$ be a partition of $[r]$ with $B \supset S := \{i \in [r] \mid n_i = 1\}$. Define*

$$K_1 := K_1(A, B) := \sum_{i \in A} \left\lfloor \frac{n_i - 2}{2} \right\rfloor + \max \left\{ 0, \left\lfloor \frac{n_B - 1}{2} \right\rfloor \right\},$$

$$K_2 := K_2(A, B) := |\{i \in A \mid n_i \text{ is odd}\}| + \begin{cases} 1 & \text{if } n_B \text{ is even and non-zero,} \\ 0 & \text{otherwise.} \end{cases}$$

Then the following lower bounds hold for the dimension of a (k, \underline{n}) -PPSN polytope:

- (1) If $0 \leq k \leq K_1$, then $\delta_{pr}(k, \underline{n}) \geq r + 1 - |B| + 2k$;
- (2) If $K_1 \leq k \leq K_1 + K_2$, then $\delta_{pr}(k, \underline{n}) \geq r + 1 - |B| + K_1 + k$;
- (3) If $K_1 + K_2 \leq k$, then $\delta_{pr}(k, \underline{n}) \geq r + 1 - |B| + 2K_1 + K_2$.

This theorem enables us to recover Theorem 4.9 and Theorem 4.10:

Corollary 4.13. *Let $k \geq 0$ and $\underline{n} := (n_1, \dots, n_r)$ with $r \geq 1$ and $n_i \geq 1$ for all i , and define $S := \{i \in [r] \mid n_i = 1\}$ and $R := \{i \in [r] \mid n_i \geq 2\}$.*

(1) *If*

$$0 \leq k \leq \sum_{i \in R} \left\lfloor \frac{n_i - 2}{2} \right\rfloor + \max \left\{ 0, \left\lfloor \frac{|S| - 1}{2} \right\rfloor \right\},$$

then $\delta_{pr}(k, \underline{n}) \geq 2k + |R| + 1$.

(2) *If $k \geq \lfloor \frac{1}{2} \sum n_i \rfloor$ then $\delta_{pr}(k, \underline{n}) \geq \sum_i n_i$.*

Proof. Take $A = R$ and $B = S$ for (1), and $A = \emptyset$ and $B = [r]$ for (2). □

4.5. Explicit lower bounds. There is an algorithm to explicitly choose the partitions $[r] = A \uplus B$ which yield the best bounds in Theorem 4.12. Since this algorithm is quite technical, we just present the best results we obtain with this topological obstruction. We refer to [MMPP09] for further details.

We fix $K_1 = K_1(R, S)$ and define $d_0 = r + 1 - |S|$ and $n = \sum_{i \in [r]} n_i$. The best lower bound d_k that we obtain with this coloring can be summarized explicitly by the following case distinction — see Figure 9:

- A.** *When $|S|$ is even and non-zero:* The bound d_k increases by two for $0 \leq k \leq K_1$. Then for each odd $n_i \geq 3$ we get a block with a first increment by one and a second increment by two. Then all increments are one until we reach the trivial bound $d_k = n = \sum_{i \in [r]} n_i$.
- B.** *When $|S|$ is odd:* As in case **A**, except that the first block corresponding to an odd $n_i \geq 3$ consists only of one increment by one.
- C.** *When $|S| = 0$ and there is an odd n_i :* As in the cases **A** and **B**, except that the first two blocks corresponding to odd n_i 's consists only of one increment. If there is only one odd n_i then all increments from K_1 on are one until we reach the trivial bound.
- D.** *When all n_i are even:* The bound d_k increases by two for $0 \leq k \leq K_1$. The next increment is zero, and all further increments are one until we reach the trivial bound $d_k = n = \sum_{i \in [r]} n_i$.

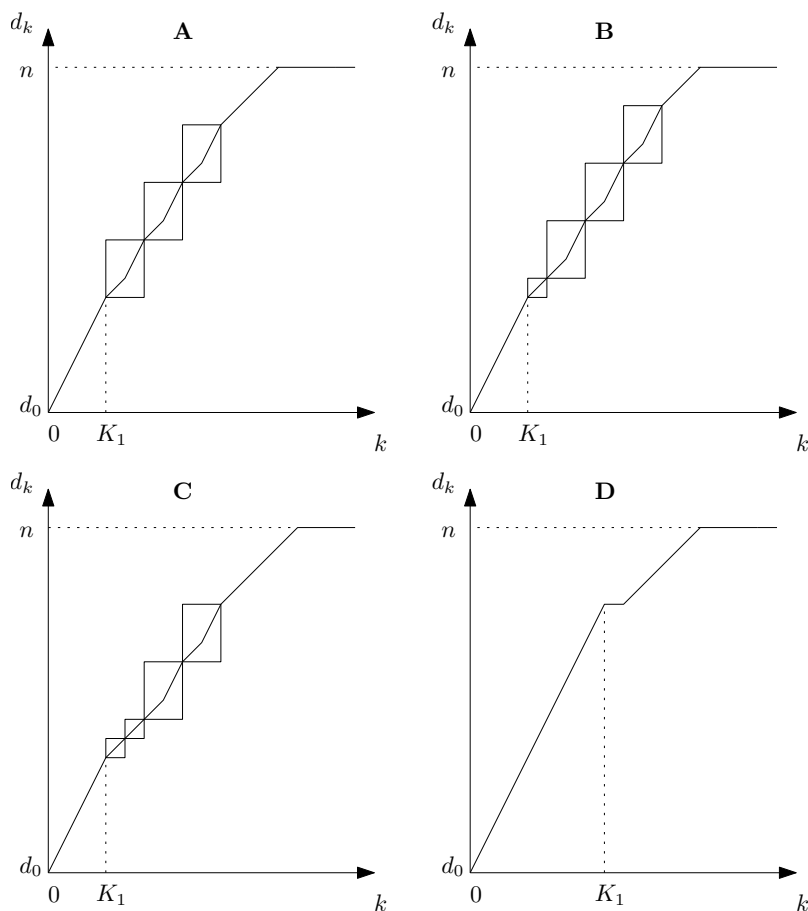

FIGURE 9. Four different situations for the lower bound.

Remark 4.14. Remark 4.11 still provides a better bound for certain cases, as for example when $k = 2$ and $\underline{n} = (4, 2)$.

4.6. Comparison with Rörig and Sanyal’s results. In [RS09], Rörig and Sanyal address the special case $n_1 = \dots = n_r =: n$ and $r \geq 2$. In their Theorem 4.5, they obtained the following bound:

$$\delta_{pr}(k, (n, \dots, n)) \geq \begin{cases} 2k + r + 1, & \text{if } 0 \leq k \leq r \lfloor \frac{n-2}{2} \rfloor, \\ k + \frac{1}{2}r(n-1) + 1, & \text{if } r \lfloor \frac{n-2}{2} \rfloor < k \leq r \lfloor \frac{n-1}{2} \rfloor, \\ \alpha + r(n-1) + 1, & \text{if } r \lfloor \frac{n-1}{2} \rfloor < k \leq rn, \end{cases}$$

where $\alpha := \left\lfloor \frac{k-r \lfloor \frac{n-1}{2} \rfloor}{\lfloor \frac{n+2}{2} \rfloor} \right\rfloor$. We compare this with the graphs C (if n is odd) and D (if n is even) of Figure 9. Their first case matches exactly with the bounds of this paper, since $K_1 = r \lfloor \frac{n-2}{2} \rfloor$. Plugging in $k = K_1$ into their first two cases yields the same bound if n is odd, but a different one if n is even. If n is even then the difference is $\lfloor \frac{r}{2} \rfloor$. The bound in their second case has slope one, that is, it increases by one if k increases by one, and the bound in their third case has a much smaller slope. Hence the bounds of Section 4.5 are stronger,

especially around $k \approx \frac{rn}{2}$. In the case $r = 1$ both bounds are equal, because at $k = K_1$ we already reach the best possible bound rn .

ACKNOWLEDGEMENTS

We thank Bernardo González Merino for extensive and fruitful discussions on the material presented here.

We are indebted to Thilo Rörig and Raman Sanyal for discussions and comments on the subject of this paper, and their very careful reading of an earlier draft.

We are grateful to the Centre de Recerca Matemàtica (CRM) and the organizers of the i-Math Winter School DocCourse on Combinatorics and Geometry, held in the Spring of 2009 in Barcelona, for having given us the opportunity of working together during three months in a very stimulating environment.

We would like to thank Michael Joswig for suggesting to look at even polytopes.

Finally, we are grateful to the two anonymous referees for their numerous remarks that helped to improve the presentation of the paper.

REFERENCES

- [AZ99] N. Amenta and G. M. Ziegler. Deformed products and maximal shadows of polytopes. In *Advances in Discrete and Computational Geometry*, Amer. Math. Soc., Providence, Contemporary Mathematics 223, pages 57–90, 1999.
- [dLRS10] J. A. de Loera, J. Rambau, and F. Santos. *Triangulations: Structures for Algorithms and Applications*, volume 25 of *Algorithms and Computation in Mathematics*. Springer Verlag, 2010.
- [JS07] M. Joswig and T. Schröder. Neighborly cubical polytopes and spheres. *Israel J. Math.*, 159:221–242, 2007.
- [JZ00] M. Joswig and G. M. Ziegler. Neighborly cubical polytopes. *Discrete Comput. Geom.*, 24(2-3):325–344, 2000.
- [Kne55] M. Kneser. Aufgabe 360. *Jahresbericht der Deutschen Mathematiker-Vereinigung*, 2. Abt., 58:27, 1955.
- [Lov78] L. Lovász. Kneser’s conjecture, chromatic number, and homotopy. *J. Combin. Theory, Ser. A*, 25:319–324, 1978.
- [Mat02] J. Matoušek. *Lectures on discrete geometry*, volume 212 of *Graduate Texts in Mathematics*. Springer-Verlag, New York, 2002.
- [Mat03] J. Matoušek. *Using the Borsuk-Ulam theorem*. Universitext. Springer-Verlag, Berlin, 2003. Lectures on topological methods in combinatorics and geometry, Written in cooperation with A. Björner and G. M. Ziegler.
- [MMPP09] B. Matschke, B. González Merino, J. Pfeifle, and V. Pilaud. Prodsimplicial neighborly polytopes. In Marc Noy and Julian Pfeifle, editors, *i-Math Winter School DocCourse Discrete and Computational Geometry: Vol. III: Research Reports*, pages 89–123. Centre de Recerca Matemàtica, Bellaterra, Barcelona, 2009.
- [RS09] T. Rörig and R. Sanyal. Non-projectability of polytope skeleta. [arXiv:0908.0845](https://arxiv.org/abs/0908.0845), 18 pages, 2009.
- [San09] R. Sanyal. Topological obstructions for vertex numbers of Minkowski sums. *J. Comb. Theory*, 116:168–179, 2009.
- [SZ09] R. Sanyal and G. M. Ziegler. Construction and analysis of projected deformed products. to appear in *Discrete Comput. Geom.*, 2009.
- [Zie95] G. M. Ziegler. *Lectures on polytopes*, volume 152 of *Graduate Texts in Mathematics*. Springer-Verlag, New York, 1995.
- [Zie04] G. M. Ziegler. Projected products of polygons. *Electron. Res. Announc. Amer. Math. Soc.*, 10:122–134, 2004.

TECHNISCHE UNIVERSITÄT BERLIN, GERMANY
E-mail address: benjaminmatschke@gmail.com

DEPARTAMENT DE MATEMÀTICA APLICADA II, UNIVERSITAT POLITÈCNICA DE CATALUNYA, BARCELONA,
SPAIN
E-mail address: julian.pfeifle@upc.edu

ÉQUIPE COMBINATOIRE ET OPTIMISATION, UNIVERSITÉ PIERRE ET MARIE CURIE, PARIS, FRANCE
E-mail address: vpilaud@math.jussieu.fr