



HAL
open science

A Friction-Test Benchmark with Twintex PP

Ulrich Sachs, Konstantine Fetfatsidis, Josefine Schumacher, Gerhard Ziegmann, Samir Allaoui, Gilles Hivet, Emmanuelle Vidal-Salle, Remko Akkerman

► **To cite this version:**

Ulrich Sachs, Konstantine Fetfatsidis, Josefine Schumacher, Gerhard Ziegmann, Samir Allaoui, et al..
A Friction-Test Benchmark with Twintex PP. Key Engineering Materials, 2012, 504-506, pp.307-312.
10.4028/www.scientific.net/KEM.504-506.307 . hal-00772374

HAL Id: hal-00772374

<https://hal.science/hal-00772374>

Submitted on 10 Jan 2013

HAL is a multi-disciplinary open access archive for the deposit and dissemination of scientific research documents, whether they are published or not. The documents may come from teaching and research institutions in France or abroad, or from public or private research centers.

L'archive ouverte pluridisciplinaire **HAL**, est destinée au dépôt et à la diffusion de documents scientifiques de niveau recherche, publiés ou non, émanant des établissements d'enseignement et de recherche français ou étrangers, des laboratoires publics ou privés.

A Friction-Test Benchmark with Twintex PP

U. Sachs^{1,a}, K. Fetfatsidis^{2,b}, J. Schumacher^{3,c}, G. Ziegmann^{3,d}, S. Allaoui^{4,e},
G. Hivet^{4,f}, E. Vidal-Salléand^{5,g}, and R. Akkerman^{1,h}

¹TPRC, Palatijn 15, P.O. Box 770, 7500 AT Enschede, The Netherlands

²University of Massachusetts Lowell, Dept. of Mechanical Engineering, 1 University Ave, Lowell, MA 01854, U.S.A

³TU Clausthal, Institut für Polymerwerkstoffe und Kunststofftechnik, Agricolastr. 6, 38678 Clausthal, Germany

⁴Polytech'Orléans, 8 rue Leonard de Vinci, 45072 Orléans Cedex 2, France

⁵INSA de Lyon, LAMCOS-Bâtiment Jacquard, 20 avenue Albert Einstein, 69621 Villeurbanne Cedex, France

^au.sachs@utwente.nl, ^bkonstantine_fetfatsidis@student.uml.edu, ^cjoefine.schumacher@tu-clausthal.de, ^dziegmann@puk.tu-clausthal.de, ^esamir.allaoui@univ-orleans.fr, ^fgilles.hivet@univ-orleans.fr, ^gemmanuelle.vidal-salle@insa-lyon.fr, ^hr.akkerman@utwente.nl

Keywords: friction, thermoplastic, composite, Twintex PP, benchmark

Abstract. This paper presents an update on a friction benchmark, that was proposed during the 13th ESAFORM conference. The goal is to compare different friction test set-ups [1–4] by determining the coefficient of friction (CoF) for Twintex® PP. The benchmark instructions are based on the ASTM standard D1894 [5] but also account for different friction velocities, pressures and temperatures. At the time of writing five research groups contributed to the benchmark, each with a custom designed test set-up, differing in size, mechanism, force control and temperature regulation. All tests will be conducted with woven glass reinforced polypropylene, from the same Twintex® batch. Conclusions will be drawn about the comparability of different testing methods by recognizing and analyzing systematically deviating results.

Introduction

The demand for advanced composites is increasing steadily, because of their high stiffness to weight ratio, that exceeds the traditional metal materials. A drawback of advanced composites is the complex, time-consuming and expensive fabrication. Thermoplastics composites offer a cost reduction compared to their thermoset counterparts due to fast production methods such as diaphragm forming and stamp forming. In order to control these processes a profound knowledge of the mechanisms is needed. One important mechanism is the friction between two materials in contact, and is characterized by the CoF. If thermoplastic materials are involved the CoF highly depends on sliding velocity, temperature and normal pressure. Its determination, however, is not covered by a standard procedure that accounts for all dependencies. As a result numerous different friction measurement set-ups have been developed, and a benchmark exercise is necessary to assure the comparability of these set-ups.

Benchmark description

Different friction measurement devices are benchmarked by comparing the measured kinetic CoF. The benchmark description prescribes the material and the conditions to be applied, ensuring the comparability of all devices. Still, the preparation of the samples and the detailed test procedure may vary for different devices, due to their characteristic properties and capabilities, e.g. size or heating power.

Property	Value
Weight % glass	60%
Areal weight	1485 g/m ²
Pre-consolidated sheet thickness	approx. 1 mm
Weave type	Balanced 2x2 twill

Tab. 1: Properties of Twintex® T PP 60 1485.

Property	Value
Material	Mild steel DC01
Thickness	0.05 mm
Tolerance	±0.005 mm
Standard	EN 10139
Roughness	R _a = 0.2 μm

Tab. 2: Properties of the applied mild steel foil.

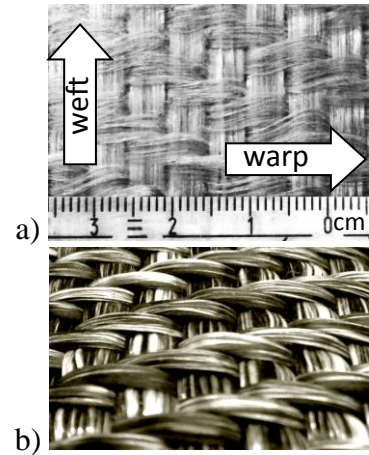

Fig. 1: 2x2 Twintex® glass polypropylene a) pre-consolidated (top view) plate b) unconsolidated fabric (side view).

Parameter	Ambient temperature		Above melting temperature	
	Baseline	Additional values	Baseline	Additional values
Temperature T [°C]	23		180	200, 220
Pressure p [kPa]	20	10, 40, 100	20	10, 40, 100
Sliding velocity U [mm/min]	60	20, 200, 1000	60	20, 200, 1000
Sliding direction	Warp-direction		Warp-direction	
Material	Unconsolidated fabric		Pre-consolidated plate	

Tab. 3: Test matrix for ambient temperature and above melting temperature

Material. The friction of 2x2 twill weave thermoplastic textile composite, Twintex® PP, against mild steel metal foil has been determined. Twintex® PP consists of comingled glass and polypropylene (PP) yarns. The material properties of the composite are given in Tab. 1. The filament counts in warp and weft direction are balanced, but Fig. 1a shows that the weave is geometrically unbalanced. The warp yarns are half as thick as the weft yarns and are clearly more undulated. The properties of the steel foil are given in Tab. 2. Tests at ambient temperature are conducted with unconsolidated fabric, while pre-consolidated plates are used for tests above the melting temperature. All participating research groups were provided with unconsolidated and pre-consolidated Twintex® from the same batch as well as steel foil.

Test matrix. The test conditions are defined by temperature T , sliding velocity U , and average pressure $p = \frac{F_N}{A}$ (see Fig. 3a for definitions). In a cross matrix one set of values form the baseline condition at which experiments are conducted. Additional test conditions are obtained by changing one baseline value while the other remain unchanged. The baseline and additional values are summarized in Tab. 3. The sliding direction is always parallel to the warp-direction (Fig. 1a). Pulling in weft-direction has a higher risk of tearing the fabric apart [2], which can be explained by the low undulation of the weft yarns (Fig. 1b), allowing the warp-yarns to slide easily along the weft-direction. Experiments for one single condition should be performed in triplicate.

Data representation. The measurements obtained by the different research groups will be benchmarked by comparing the CoF. This value is defined as the ratio between the average shear stress τ and the average normal pressure p . Depending on the set-up, friction takes place on one or two surfaces of the test specimen. The pull force for set-ups of the first type (Fig. 4b and Fig. 5) is denoted with F_S , while the notation F_H is used for set-ups of the second type (Fig. 3 and Fig. 4a). The CoF can be calculated as:

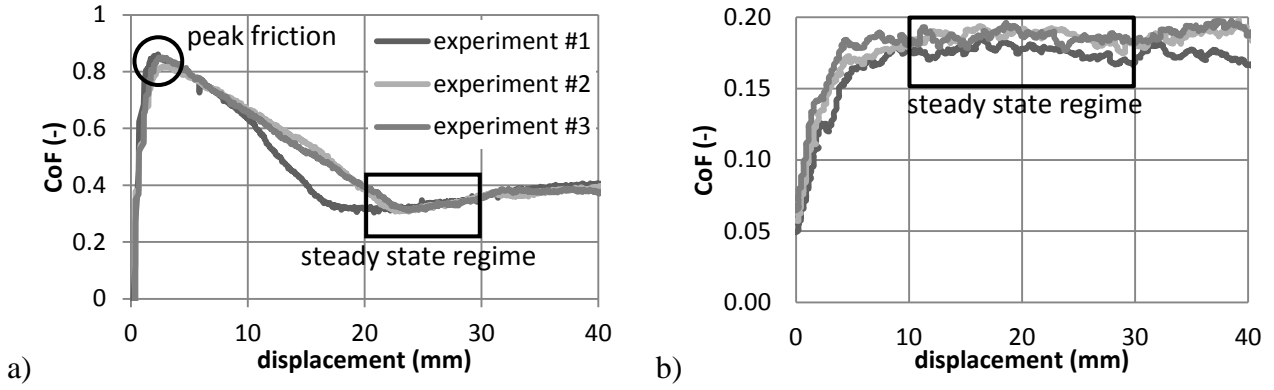

Fig. 2: Exemplary friction measurement: a) wet friction conducted at $T=180^{\circ}\text{C}$; $p=10\text{kPa}$ and $U=60\text{mm/min}$, b) dry friction conducted at $T=27^{\circ}\text{C}$; $p=20\text{kPa}$ and $U=60\text{mm/min}$.

$$\text{CoF} = \frac{\tau}{p} = \frac{F_H}{2A} \frac{A}{F_N} = \frac{F_H}{2F_N} \quad \text{or} \quad \text{CoF} = \frac{\tau}{p} = \frac{F_S}{A} \frac{A}{F_N} = \frac{F_S}{F_N} \quad (1)$$

In Fig. 2 exemplary friction measurements are shown as a function of the displacement between specimen and tooling. Two characteristic values are determined for each experiment: firstly, the peak friction, defined as the maximum friction during the start-up regime and secondly, the steady state friction, defined as the average friction in the steady state regime. One group has observed wear phenomena after 30mm displacement. Therefore, this value defines the maximum of the steady state regime. Most groups did not observe a prominent peak friction in the experiments for dry friction (Fig. 2b), and will therefore be disregarded. The steady state and peak friction, measured under the same conditions, will be presented by taking their arithmetic mean and the standard deviation, according to the ASTM standard D1894 [5].

Measurement devices

UTwente. The measurement device developed at the University of Twente [6] (Fig. 3a) operates in a universal testing machine. A flexible pneumatic actuator supplies the normal load F_N in a self-aligning system. The normal load is measured by load cells. Thick blocks minimize the tool deflection, whereas the overlapping edges are used to pre-heat the laminate before it enters the contact area. Temperatures are measured in both blocks with multiple thermocouples. The normal force F_N exerts a pressure p on the test specimen and is measured by 3 load cells.

UML. The set-up deployed by the University of Massachusetts Lowell is shown in Fig. 3b. Each test sample was cut to half of the area of the pressure plates such that the nominal friction area

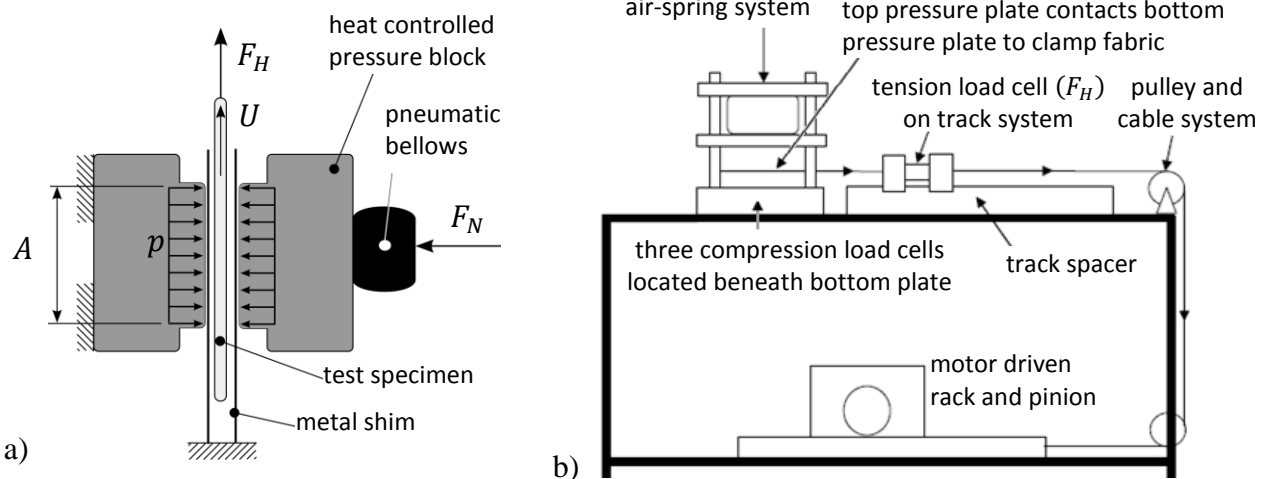

Fig. 3: Schematic representation of experimental set-up a) “University of Twente”, b) “University of Massachusetts Lowell”.

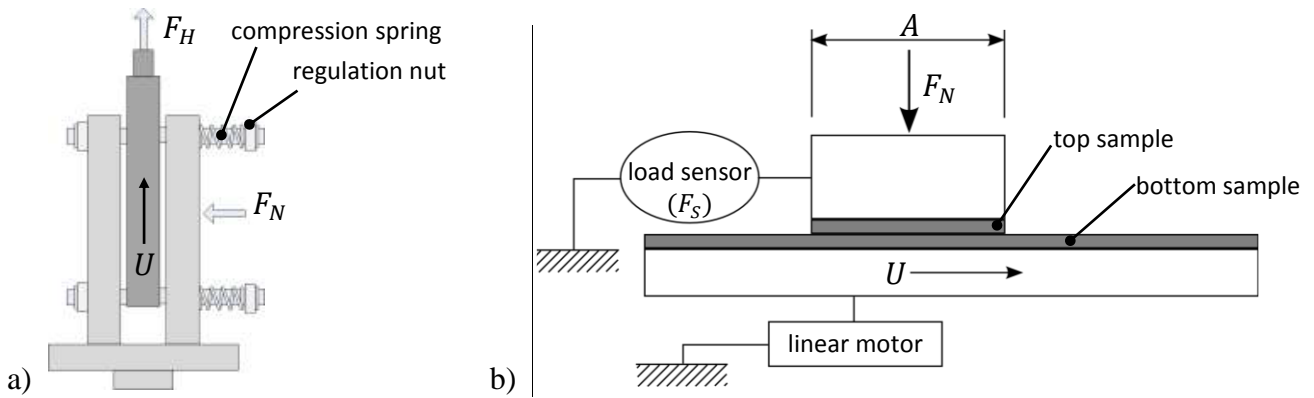

Fig. 4: Schematic representation of experimental set-up a) “Clausthal University of Technology”, b) “University of Orléans”.

remains constant while pulling the sample through the pressure plates. The normal force, exerted by an air-spring system, is feedback controlled by compression load cells. The measurement device was designed to apply sliding velocities U up to 5000 mm/min and pressures p of more than 1,8 MPa. The benchmark conditions are at the lower end of this device, resulting in noise in the measured data. The noise was reduced by post-processing the data.

TU Clausthal. The experimental set-up at the Clausthal University of Technology (Fig. 4a) consists of two parallel vertical steel plates which can be displaced laterally along the sides of a horizontal base plate. A moving part intended to be pulled out during the experiment, is positioned and clamped between the parallel plates. The cumulative clamping force F_N is applied by means of four compression springs (following Hooke’s law). The compression of each spring can be regulated by tightening or loosening regulation nuts. The set-up is mounted in a universal testing machine equipped with a 10kN load cell to measure the pull force F_H . The crosshead of the universal testing machine is position controlled and moves with a constant velocity U .

Université d’Orléans. The principle of the apparatus used at the University of Orléans [4] is shown in Fig. 4b. It is based on two plane surfaces sliding relative to each other. The bottom sample is fixed on a rigidly and accurately guided steel plate. The required velocity is imposed by an electronic controlled motor. A dead weight provides a constant normal load F_N .

INSA Lyon. The testing device designed at INSA Lyon is presented in Fig. 5. The top sample is fixated under a static sample holder. A table carrying the bottom sample, is displaced laterally by a pneumatic actuator. Sensors measure the displacement, the frictional load F_S and normal load F_N . The angle between the two samples (i.e. sliding orientation) can be adjusted by rotating the static sample holder. Since the sliding velocity is governed by the air pressure we can speak of a force controlled system.

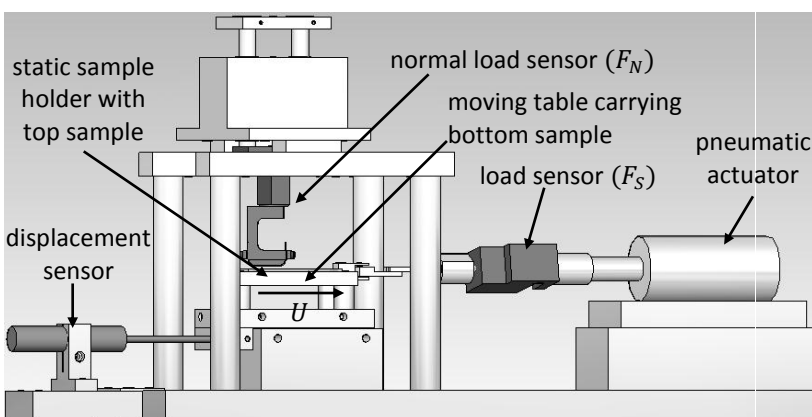

Fig. 5: Experimental set-up “INSA Lyon”.

	A (mm ²)
TU Clausthal	10000
University of Orléans	4500
UML	4000
UTwente	2500
INSA Lyon	300

Tab. 4: Size of nominal friction area A for different set-ups.

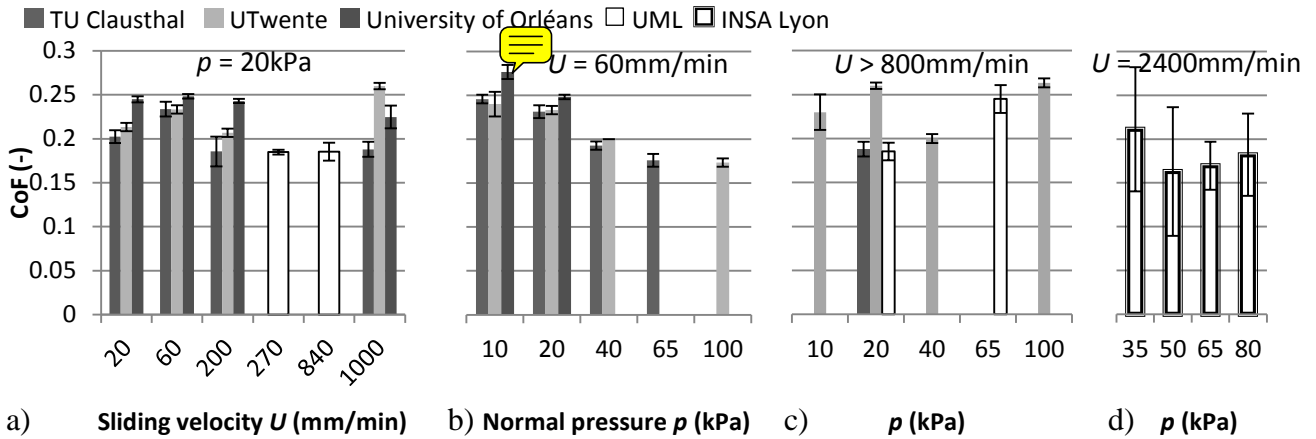

Fig. 6: Steady state friction coefficients for dry friction experiments conducted by different research groups, a) varying sliding velocity at $p=20\text{kPa}$, b) varying normal pressure at $U=60\text{mm/min}$, c) at $U=840\text{mm/min}$ (UML) and $U=1000\text{mm/min}$ (TU Clausthal and UTwente), d) at $U=2400\text{mm/min}$ (INSA Lyon). The CoF is presented by the arithmetic mean and standard deviation of at least three measurements.

Results

Dry friction test. At the moment of writing five benchmark participants have conducted measurements, which are compared in Fig. 6. The results of the research groups are comparable. Small standard deviations indicate that the CoF can be determined quite accurately, independent of the used measurement device. However, the measurements taken at $p=20\text{kPa}$ and $U=1000\text{mm/min}$ conducted at the University of Twente are exceptionally high. A systematic error may be present here. The CoFs at the highest sliding velocity of $U=2400\text{mm/min}$ measured by INSA Lyon (Fig. 6d), are relatively low and exhibit great standard deviations. If this is due to the velocity or to device specifications still needs to be determined. Compared to others, the device has a very small nominal friction area (see Tab. 4). Fig. 6a relates the friction coefficient to the sliding velocity. Except for one outlier, the CoF remains between 0.25 and 0.18 without exhibiting a clear trend. University of Orléans measured higher CoFs than TU Clausthal, while those of the University of Twente mostly lay inbetween. Fig. 6b relates the CoF to the normal pressure at a sliding velocity of $U=60\text{mm/min}$. A decreasing trend can be observed, while for a higher velocity of $U>800\text{mm/min}$ the reversed tendency is observed between 20kPa and 100kPa (Fig. 6c).

Wet friction test. Experimental data of only one group was available and is presented in Fig. 7. Clear trends can be observed. The friction coefficient is increasing with increasing sliding velocity, decreasing pressure or decreasing temperature. That holds for the steady state as well as for the

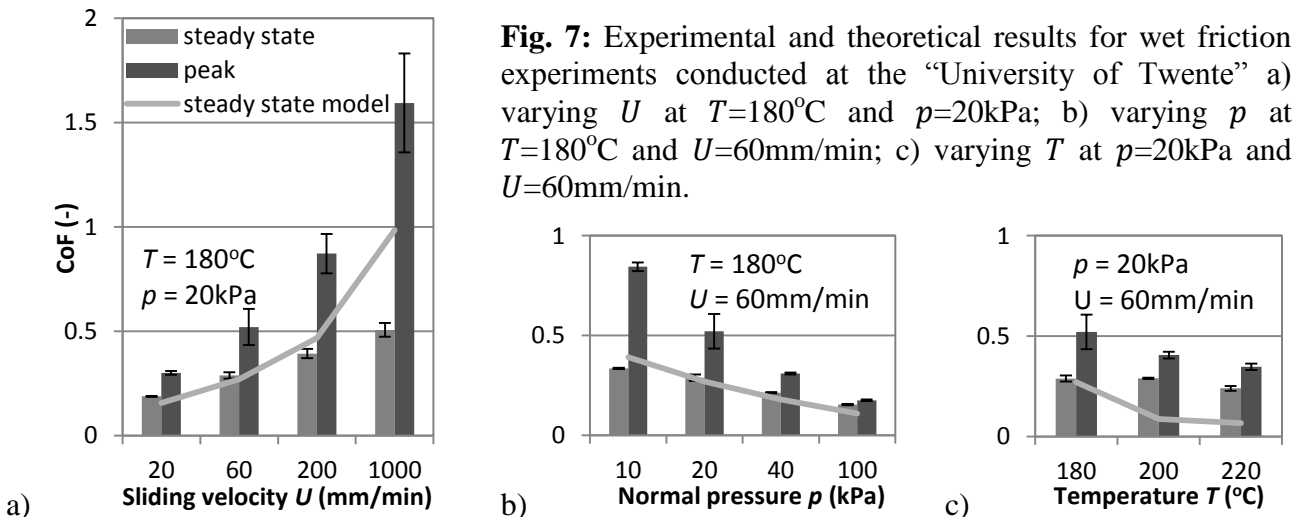

Fig. 7: Experimental and theoretical results for wet friction experiments conducted at the “University of Twente” a) varying U at $T=180^\circ\text{C}$ and $p=20\text{kPa}$; b) varying p at $T=180^\circ\text{C}$ and $U=60\text{mm/min}$; c) varying T at $p=20\text{kPa}$ and $U=60\text{mm/min}$.

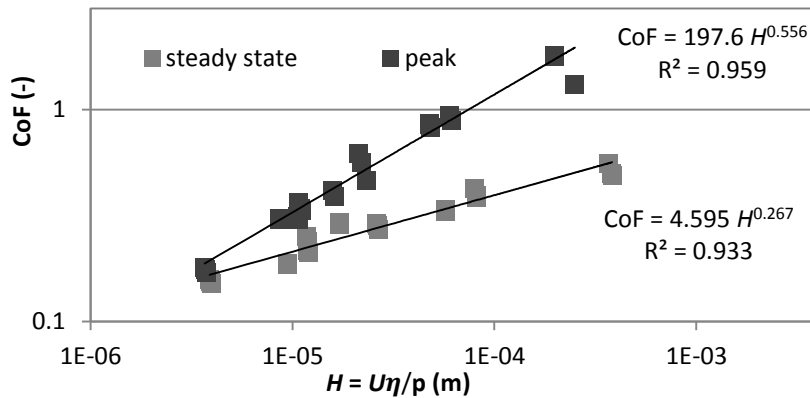

Fig. 8: Stribeck curve for steady state and peak friction values.

peak friction. This behavior is typical for full hydrodynamic lubrication. A lubrication model [7] assuming full hydrodynamic lubrication was used to obtain theoretical values for the steady state friction. Mostly they agree with the experiments.

In particular cases the three variables U , p and T can be combined to a single Hersey number [8] $H = \eta(T) U/p$, where η describes the bulk viscosity of the thermoplastic as function of the temperature T . The viscosity is obtained by rheometer experiments with polypropylene of the same grade as used in the composite. Fig. 8 relates the measured friction coefficients to the corresponding Hersey number. An approximate exponential relation has been found, for the steady state and peak friction.

Conclusions

Independent friction measurements on Twintex PP were conducted with differently constructed devices. In the case of dry friction (at ambient temperature) the results seem to be comparable. Outliers still give concern about systematic errors. Dependencies of the dry friction on boundary conditions like sliding velocity and normal pressure are suspected. The benchmark is based on a small data set, which needs to be extended by the remaining benchmark participants. In the case of wet friction (temperature above melting point) only one group provided data. This data agrees with a theoretical model, which assumes full hydrodynamic lubrication.

References

- [1] J.L. Gorkczyca-Cole, J.A. Sherwood, and J. Chen, A friction model for thermostamping commingled glass–polypropylene woven fabrics, *Composites Part A: Applied Science and Manufacturing*, 38 (2007) 393-406.
- [2] R.H.W. ten Thije, R. Akkerman, L. van der Meer, and M.P. Ubbink, Tool-ply friction in thermoplastic composite forming, *Int. J. Mat. Form.*, 1 (2008) 953-956.
- [3] P. Harrison, H. Lin, M. Ubbink, R. Akkerman, K. Van De Haar, and A.C. Long, Characterising and modelling tool-ply friction of viscous textile composites, *ICCM International Conferences on Composite Materials*, (2007).
- [4] S. Allaoui, G. Hivet, and J.L. Billoët, Experimental Analysis of the Contact Between Layers of Dry Fabrics, *Int. J. Mat. Form.*, 2 (2009) 209-212.
- [5] Standard Test Method for Static and Kinetic Coefficients of Friction of Plastic Film and Sheeting, ASTM Standard D1894-01. ASTM International, West Conshohocken, PA, (2001).
- [6] R. Akkerman, R. Ten Thije, U. Sachs, and M. De Rooij, Friction in textile thermoplastic composites forming, *Proceedings of the 10th International Conference on Textile Composites - TEXCOMP 10: Recent Advances in Textile Composites*, (2010), 271-279.
- [7] R.H.W. ten Thije, R. Akkerman, M. Ubbink, and L. van der Meer, A lubrication approach to friction in thermoplastic composites forming processes, *Composites Part A: Applied Science and Manufacturing*, 42 (2011) 950-960.
- [8] A. van Beek, *Tribologie: levensduur en prestatie*. Technische Universiteit Delft, (2001).