



**HAL**  
open science

# Spurious lattice solitons for linear finite difference schemes

Claire David

► **To cite this version:**

| Claire David. Spurious lattice solitons for linear finite difference schemes. 2013. hal-00770992

**HAL Id: hal-00770992**

**<https://hal.science/hal-00770992>**

Preprint submitted on 7 Jan 2013

**HAL** is a multi-disciplinary open access archive for the deposit and dissemination of scientific research documents, whether they are published or not. The documents may come from teaching and research institutions in France or abroad, or from public or private research centers.

L'archive ouverte pluridisciplinaire **HAL**, est destinée au dépôt et à la diffusion de documents scientifiques de niveau recherche, publiés ou non, émanant des établissements d'enseignement et de recherche français ou étrangers, des laboratoires publics ou privés.

# Spurious lattice solitons for linear finite difference schemes

Claire David \*

\*Université Pierre et Marie Curie-Paris 6

Laboratoire Jacques-Louis Lions, UMR CNRS 7598

Boîte courrier n<sup>o</sup>187, 4 place Jussieu, F-75252 Paris, cedex 05, France

†Claire.David@upmc.fr

January 7, 2013

## Abstract

The goal of this work is to show that lattice solitons are solution of the general linear finite-differenced version of the linear advection equation. The occurrence of such a spurious solitons, which exhibits a very long life time, results in a non-vanishing numerical error for arbitrary time in unbounded numerical domain. Such a behavior is referred here to have a structural instability of the scheme, since the space of solutions spanned by the numerical scheme encompasses types of solutions that are not solutions of the original continuous equations. What can be of noticeable interest is the link established between linear finite difference schemes and the DST equation (Discrete Self Trapping Equation).

**Key Words:** Numerical schemes; spurious lattice solitary waves.

**AMS Subject Classification:** 65 M06, 65M12, 65M60, 35B99.

**PACS Codes:** 47.11.Bc, 647.35.Fg.

# 1 Introduction

The analysis and the control of numerical error in discretized propagation-type equations is of major importance for both theoretical analysis and practical applications. A huge amount of works has been devoted to the analysis of the numerical errors, its dynamics and its influence on the computed solution (the reader is referred to classical books, among which [1, 5]). It appears that existing works are mostly devoted to linear, one-dimensional numerical models, such as the linear advection equation

$$\frac{\partial u}{\partial t} + c \frac{\partial u}{\partial x} = 0 \quad (1)$$

where  $c$  is a constant uniform advection velocity. A striking observation is that, despite the tremendous efforts devoted to the analysis of numerical schemes in this simple case, the full exact non-homogeneous error equation has been derived only very recently [8].

The two sources of numerical error are the dispersive and dissipative properties of the numerical scheme, which are very often investigated in unbounded or periodic domains thanks to a spectral analysis. In previous work [9], we analyzed a linear dispersive mechanism which results in local error focusing, i.e. to a sudden local error burst in the  $L_\infty$  norm for polychromatic solutions, referred to as the spurious caustic phenomenon. We showed that, for some specific values of the Courant number, spurious caustics can exist for some popular finite-difference schemes.

In other works [10], [11] we have determined classes of traveling solitary wave solutions for a differential approximation of a finite difference scheme by means of a hyperbolic ansatz. We showed that spurious solitary waves can occur in finite-difference solutions of nonlinear wave equation. The occurrence of such a spurious solitary wave, which exhibits a very long life time, results in a non-vanishing numerical error for arbitrary time in unbounded numerical domain. Such a behavior is referred here to have a structural instability of the scheme, since the space of solutions spanned by the numerical scheme encompasses types of solutions (solitary waves in the present case) that are not solution of the original continuous equations.

In physics, mathematics or engineering, a spurious solution refers to a non-physical one, which bears no resemblance to real one (see, for instance, [12].) Sometimes, a spurious solution may just mean an unwelcome or unexpected artifact. To avoid an unwelcome spurious solution, one has to find out its true origin, which in general can be due to either physical and mathematical modelings, or numerical methods. Spurious solutions induced by mathematical modeling are usually due to the

## Spurious lattice solitons

missing of certain analytical constraints in mathematical formulations. Yet, the most interesting spurious solutions are those that are directly related to numerical methods, i.e., spurious solutions induced by algorithm.

Analysis of spurious waves in the numerical approximation of a one dimensional advection equation has been extensively investigated over the past few years by means of Fourier Analysis, through the concept of group velocity (see [13], [14], [15]). It was also the kind of technique we used in [9].

In the present study, we investigate a new kind of spurious solution, which might appear in the process of the numerical scheme, when a solution which is not the searched one appears to satisfy the recursive difference relation and emerges through the numerical computation. Following [16], and the fact that a wide class of numerical instabilities can be interpreted as spurious triad wave interactions generated by discretization, we show that such a spurious solution could then be related to a kind of "locking" of the scheme, since it takes the place of the searched one and gives birth to a wrong solution.

We thus presently extend our previous works, in so far as we exhibit lattice solitary waves solution of the general linear finite-differenced version of the linear advection equation, rejoining the fact that there exists travelling solitary wave solutions for a differential approximation of a finite difference scheme.

So far, we would like to lay the emphasis on the fact that, contrary to most beliefs, solitary waves and solitons can not uniquely be obtained as solutions of nonlinear differential equations and as solutions of linear differential equations, as it is very well shown in the very interesting paper of C. Radhakrishnan [17], where, taking the example of the Korteweg-de Vries equation, it is shown that soliton solutions need not always be the consequence of the trade-off between the nonlinear terms and the dispersive term in the nonlinear differential equation, and that even the ordinary one dimensional linear partial differential equation can produce a soliton. The author explains that solutions of both linear and nonlinear differential equations are functions which depend nonlinearly on the independent variable, and that one can construct linear as well as nonlinear differential equations from the same function, as it is the case for the linear advection equation. Thus, as it is explained, the claim that a particular physical phenomenon can be described only by a nonlinear differential equation, and not by any linear differential equation is not tenable, provided a linear differential equation with the same solution as that of the nonlinear differential equation exists, and that, incidentally, linearization is the oldest and most popular method of solving nonlinear differential equations. In

## Spurious lattice solitons

the same way, in [18], Liu et al. proved the existence of solitary waves in Linear ODE with variable coefficients.

In the present paper, we consider the linear advection equation (1), which happens to be obtained by linearizing the nonlinear Burgers equation.

Our analysis is restricted to interior stencil, and the influence of boundary conditions will not be considered.

## 2 Test numerical schemes

A linear finite difference scheme for the Burgers equation can be written under the following general form:

$$F(u_l^m, h, \tau) = 0, \quad (2)$$

where the discrete solution is denoted

$$u_l^m = u(l dx, m dt) \quad (3)$$

$l \in \{j-1, j, j+1\}$ ,  $m \in \{n-1, n, n+1\}$ ,  $j = 1, \dots, n_x$ ,  $n = 1, \dots, n_t$ ,  $h, \tau$  denoting respectively the mesh size and time step, and  $\sigma$  the Courant-Friedrichs-Lewy number (*cfl*) coefficient, defined as  $\sigma = c\tau/h$ .

A numerical scheme is specified by selecting appropriate expression of the linear function  $F$  in equation (2).

For the sake of simplicity, the analysis will be restricted to schemes which involves at most two time levels and three grid points. The extension of the present analysis to other schemes is straightforward. For this class of schemes, the general finite-differenced version of the linear advection equation (1) can therefore be written as follows

$$\frac{u_j^{n+1} - u_j^n}{\tau} + \sum_{k=j-1}^{j+1} m_{jk} u_k^n = 0 \quad (4)$$

where  $m_{jk}$  are coefficients related to the numerical scheme. Those coefficients are constants, and can take only three different values, that we will denote  $m^-$ ,  $m$ ,  $m^+$ , which implies that the matrix

$$[m_{jk}]_{1 \leq j \leq n_x, 1 \leq k \leq n_t}$$

is a block cyclic one, of the form:

## Spurious lattice solitons

$$M = \begin{bmatrix} m & m^{+0} & \dots & \dots & \dots & 0 \\ m^{-} & m & m^{+} & 0 & \dots & 0 \\ 0 & m^{-} & m & m^{+} & 0 & \dots & 0 \\ \vdots & \dots & \dots & \dots & \dots & \dots & \dots \end{bmatrix} \quad (5)$$

If one writes it under the form:

$$\frac{du_j^n}{dt} + \sum_{k=j-1}^{j+1} m_{jk} u_k^n = 0 \quad (6)$$

where the  $m_{jk}$  denote the linear scheme coefficients, it appears as a special case of a more general equation, the *Discrete Self-Trapping (DST)* equation (see, among numerous references, [19], [20], [21]):

$$\frac{dA_j}{dt} + \gamma A_j^2 A_j + \varepsilon \sum_{k \in I} m_{jk} A_k = 0 \quad (7)$$

where:

$$\gamma = 0 \quad (8)$$

and where  $I$  denotes a set of integers.

Nonlinear localized modes in discrete systems exist due to the interplay between lattice coupling and nonlinearity effects. We presently aim at proving that finite difference schemes admit spatially localized modes or discrete solitons. It is a fundamental property of discrete systems, or, more generally, spatially periodic systems with a band-gap structure for the dispersion relation of linear waves, that bright and dark localized modes may appear for the same physical system.

It is well known that depending upon of the parameters and the chosen initial condition the *DST* equation can lead either to self-trapping (i.e. local modes or solitons), or to chaos, or to a mixture of the above two behaviors (see [19], [22], [23]).

It has been shown that the *DST* equation is not integrable when  $\max\{n_x, n_t\} > 2$ , and, thus, will admit Hamiltonian chaos [19].

The classical way to obtain discrete soliton solutions (see, for instance [24]) is to consider a travelling wave ansatz for an envelope complex function reading as:

$$\phi_j(x, t) = \sum_{\Lambda=0}^{+\infty} \psi_j(\xi) e^{i\Lambda\theta} \quad (9)$$

## Spurious lattice solitons

where

$$\begin{cases} \xi &= x - v_j t \\ \theta &= \delta_j + \omega_j t \end{cases} \quad (10)$$

where  $v_j$  is a velocity,  $\delta_j$  is a phase,  $\omega_j$  a constant related to the particle energy, and where  $\Lambda$  represents a phase shift among successive discrete sites, and, in essence, translates the spatial carrier wave number within the Brillouin zone<sup>1</sup>.

Usually, one uses then the full Taylor expansion of the function  $\psi_{j\pm 1} \rightarrow e^{\pm \delta_j} \psi_j$  to transform eq. (7) into an operator equation. In the following, we choose to directly search exact solutions without this approximation.

Solitary waves solutions can be searched using a hyperbolic ansatz (see [25], [26]), as a combination of bell-profile and kink-profile waves, of the form:

$$U(x, t) = \sum_{p=1}^{N_p} \{U_p \tanh^p [C_p (x - v t + x_0)] + V_p \operatorname{sech}^p [C_p (x - v t + x_0)]\} \quad (11)$$

where  $N_p$  is a positive integer,  $U_p, V_p, C_p$ , constants;  $v$  denotes the velocity. Due to the  $p^{\text{th}}$  exponents that lead to over-determined algebraic equations, one usually work in the case  $N_p = 1$ .

**Proposition 2.1.** *Expression (11) can be obtained searching solitary wave solutions as the following infinite series:*

$$\phi_j(x, t) = \sum_{\Lambda=-\infty}^{+\infty} \Psi_j e^{\Lambda (k_j x - v_j t)} \quad (12)$$

*Proof.* Set:

$$\xi = x - v t + x_0 \quad (13)$$

The proof is in the case where  $C_p \xi > 0$ .

---

<sup>1</sup>the Brillouin zone, or first Brillouin zone, is a uniquely defined primitive cell in reciprocal space, which boundaries are given by planes related to points on the reciprocal lattice. The importance of the Brillouin zone stems from the Bloch wave description of waves in a periodic medium, i.e. by means of their wavefunction [27], in which it is found that the solutions can be completely characterized by their behavior in a single Brillouin zone.

## Spurious lattice solitons

One has then:

$$\begin{aligned}
U(x, t) &= \sum_{p=1}^{N_p} \{U_p \tanh^p [C_p \xi] + V_p \operatorname{sech}^p [C_p \xi]\} \\
&= \sum_{p=1}^{N_p} \left\{ U_p \left( \frac{e^{C_p \xi} - e^{-C_p \xi}}{e^{C_p \xi} + e^{-C_p \xi}} \right)^p + V_p \left( \frac{2}{e^{C_p \xi} + e^{-C_p \xi}} \right)^p \right\} \\
&= \sum_{p=1}^{N_p} \left\{ U_p \left( \frac{1 - e^{-2C_p \xi}}{1 + e^{-2C_p \xi}} \right)^p + V_p \left( \frac{2 e^{-C_p \xi}}{1 + e^{-2C_p \xi}} \right)^p \right\} \\
&= \sum_{p=1}^{N_p} \left\{ U_p \left( \sum_{k=0}^p (-1)^k e^{-2k C_p \xi} \right) + 2^p e^{-p C_p \xi} V_p \right\} \left\{ \sum_{l=0}^{+\infty} (-1)^l e^{-2l C_p \xi} \right\}^p
\end{aligned} \tag{14}$$

The term  $\left\{ \sum_{l=0}^{+\infty} (-1)^l e^{-2l C_p \xi} \right\}^p$ , that we will call a  $p$ -Cauchy product, is obtained

by applying  $p$  times the Cauchy product to the infinite series  $\sum_{l=0}^{+\infty} (-1)^l e^{-2l C_p \xi}$ .

Thus, this latter term can be written under the form

$$\left\{ \sum_{l=0}^{+\infty} (-1)^l e^{-2l C_p \xi} \right\}^p = \sum_{m=0}^{+\infty} c_{m,p} e^{-2m C_p \xi} \tag{15}$$

where the  $c_{m,p}$  denote the coefficients of the  $p$ -Cauchy product. Thus, expression (11) can be written under the following form:

$$U(x, t) = \sum_{\Lambda=-\infty}^{+\infty} d_{\Lambda} e^{\Lambda C_p \xi} \tag{16}$$

□

We thus search for solitary waves under the form:

$$\phi_j(x, t) = \sum_{\Lambda=-\infty}^{+\infty} \Psi_j e^{\Lambda(k_j x - v_j t)} \tag{17}$$

which appear to be a more general one. Expressions of the form (11) appear thus a particular case of (17).



## Spurious lattice solitons

Since we are considering the solution at the  $j^{\text{th}}$  node of the mesh, at the time  $n\tau$ , we will have:

$$\begin{cases} x = j h \\ t = n \tau \end{cases} \quad (18)$$

By substituting (17) in (6), one obtains:

$$-\Lambda v_j \Psi_j e^{\Lambda(k_j x - v_j t)} + \sum_{k=j-1}^{j+1} m_{jk} \Psi_k e^{\Lambda(k_k x - v_k t)} = 0 \quad (19)$$

If, by following again [25], [26], one makes the assumption that, for any value of the integer  $j$  in  $\{0, \dots, n_x\}$ :

$$\begin{cases} k_j = k_{j\pm 1} = k \\ v_j = v_{j\pm 1} = v \end{cases} \quad (20)$$

due to the fact that the characteristic scheme coefficients are constants and cyclically take the values  $m^-$ ,  $m$ ,  $m^+$ , it leads to:

$$-\Lambda v \Psi_j + m^- \Psi_{j-1} + m \Psi_j + m^+ \Psi_{j+1} = 0 \quad (21)$$

or:

$$(m - \Lambda v) \Psi_j + m^- \Psi_{j-1} + m^+ \Psi_{j+1} = 0 \quad (22)$$

which appears to be a second-order recurrence solution with regards to  $\psi_j$ , whose characteristic equation is given by:

$$m^+ r^2 + (m - \Lambda v) r + m^- = 0 \quad (23)$$

The discriminant is given by:

$$(m - \Lambda v)^2 - 4 m^+ m^- \quad (24)$$

If  $m^+ m^- < 0$ , real solutions always exist. If, on the contrary, If  $m^- m^- > 0$ , real solutions exist if:

$$|m - \Lambda v| \geq 2 \sqrt{|m^+ m^-|} \quad (25)$$

The solutions are then given by:

$$r = \frac{-m - \Lambda v \pm \sqrt{(m - \Lambda v)^2 - 4 m^+ m^-}}{2} \quad (26)$$

## Spurious lattice solitons

From now on, we set:

$$\begin{cases} r_{1\Lambda} &= \frac{-m + \Lambda v - \sqrt{(m - \Lambda v)^2 - 4m^+ m^-}}{2} \\ r_{2\Lambda} &= \frac{-m + \Lambda v + \sqrt{(m - \Lambda v)^2 - 4m^+ m^-}}{2} \end{cases} \quad (27)$$

which ensures, for any  $\psi_j$ :

$$\Psi_j = a(\Lambda) r_{1\Lambda}^j + b(\Lambda) r_{2\Lambda}^j \quad (28)$$

where  $a(\Lambda)$ ,  $b(\Lambda)$  are constants that will be determined using the boundary conditions.

Set:

$$\psi_\infty = \lim_{n \rightarrow +\infty} \psi_n = \psi(n_x) \quad (29)$$

Since we deal with the Burgers equation, we assume that the boundary conditions are of Dirichlet type, periodic:

$$u(x = 0, t) = u(x = n_x h, t) \quad (30)$$

with an initial condition:

$$u(x, 0) = u_0(x) \quad (31)$$

which leads to:

$$\psi_0 = \psi_\infty \quad (32)$$

It ensures:

$$\begin{cases} a(\Lambda) + b(\Lambda) &= \psi_\infty \\ a(\Lambda) r_{1\Lambda}^{n_x} + b(\Lambda) r_{2\Lambda}^{-n_x} &= \psi_\infty \end{cases} \quad (33)$$

which yields:

$$\begin{cases} a(\Lambda) &= \frac{\psi_\infty (1 - r_{2\Lambda}^{n_x})}{r_{1\Lambda}^{n_x} - r_{2\Lambda}^{n_x}} \\ b(\Lambda) &= \frac{\psi_\infty (r_{1\Lambda}^{n_x} - 1)}{r_{1\Lambda}^{n_x} - r_{2\Lambda}^{n_x}} \end{cases} \quad (34)$$

## Spurious lattice solitons

### 3 Numerical example: the case of the Lax scheme

For the classical Lax scheme, the finite difference relation writes:

$$\frac{1}{\tau} u_j^{n+1} + \left( \frac{-1}{2\tau} + \frac{c}{2h} \right) u_{j+1}^n - \left( \frac{1}{2\tau} + \frac{c}{2h} \right) u_{j-1}^n = 0 \quad (35)$$

which is equivalent to

$$\frac{1}{\tau} u_j^{n+1} + \left( \frac{1}{\tau} - \frac{1}{\tau} \right) u_j^n + \left( \frac{-1}{2\tau} + \frac{c}{2h} \right) u_{j+1}^n - \left( \frac{1}{2\tau} + \frac{c}{2h} \right) u_{j-1}^n = 0 \quad (36)$$

so that one obtains:

$$\frac{u_j^{n+1} - u_j^n}{\tau} + \frac{1}{\tau} u_j^n + \left( \frac{-1}{2\tau} + \frac{c}{2h} \right) u_{j+1}^n - \left( \frac{1}{2\tau} + \frac{c}{2h} \right) u_{j-1}^n = 0 \quad (37)$$

that we can write as:

$$\frac{du_j^n}{dt} + \frac{1}{\tau} u_j^n + \left( \frac{-1}{2\tau} + \frac{c}{2h} \right) u_{j+1}^n - \left( \frac{1}{2\tau} + \frac{c}{2h} \right) u_{j-1}^n = 0 \quad (38)$$

Identification leads then to the following values for the characteristic scheme coefficients  $m^-$ ,  $m$ ,  $m^+$ :

$$\begin{cases} m^- &= \frac{1}{2\tau} - \frac{c}{2h} \\ m &= \frac{1}{\tau} \\ m^+ &= -\frac{1}{2\tau} - \frac{c}{2h} \end{cases} \quad (39)$$

It leads to:

$$m^+ m^- = - \left( \frac{1}{2\tau} - \frac{c}{2h} \right) \left( \frac{1}{2\tau} + \frac{c}{2h} \right) = -\frac{1}{4\tau^2} + \frac{c^2}{4h^2} = \frac{\sigma^2 - 1}{4\tau^2} < 0 \quad (40)$$

since the *cfl* number  $\sigma$  satisfying  $0 \leq \sigma \leq 1$ .

The case  $\sigma = 1$  referring to unstable schemes will not be considered in the present study.

Hence, the solutions of (23) are real ones, given for  $v \in \mathbb{R}$  by:

## Spurious lattice solitons

$$\begin{cases} r_{1\Lambda} = \frac{-\frac{1}{\tau} + \Lambda v - \sqrt{\left(\frac{1}{\tau} - \Lambda v\right)^2 + \frac{1-\sigma^2}{\tau^2}}}{2} \\ r_{2\Lambda} = \frac{-\frac{1}{\tau} + \Lambda v + \sqrt{\left(\frac{1}{\tau} - \Lambda v\right)^2 + \frac{1-\sigma^2}{\tau^2}}}{2} \end{cases} \quad (41)$$

One has then:

$$\begin{cases} a(\Lambda) = \frac{\psi_\infty (1 - r_{2\Lambda}^{n_x})}{r_{1\Lambda}^{n_x} - r_{2\Lambda}^{n_x}} \\ b(\Lambda) = \frac{\psi_\infty (r_{1\Lambda}^{n_x} - 1)}{r_{1\Lambda}^{n_x} - r_{2\Lambda}^{n_x}} \end{cases} \quad (42)$$

and, for  $0 \leq j \leq n_x$ :

$$\Psi_j = a r_{1\Lambda}^j + b r_{2\Lambda}^j \quad (43)$$

which lead to the following spurious solution at the  $j^{th}$  node of the mesh:

$$\begin{aligned} \phi_j(x = j h, t = n \tau) &= \sum_{\Lambda=-\infty}^{+\infty} \Psi_j e^{\Lambda(k j h - n v \tau)} \\ &= \sum_{\Lambda=-\infty}^{+\infty} \left\{ a(\Lambda) r_{1\Lambda}^j + b(\Lambda) r_{2\Lambda}^j \right\} e^{\Lambda(k j h - n v \tau)} \\ &= \sum_{\Lambda=-\infty}^{+\infty} \frac{\psi_\infty}{r_{1\Lambda}^{n_x} - r_{2\Lambda}^{n_x}} \left\{ (1 - r_{2\Lambda}^{n_x}) r_{1\Lambda}^j + (r_{1\Lambda}^{n_x} - 1) r_{2\Lambda}^j \right\} e^{\Lambda(k j h - n v \tau)} \end{aligned} \quad (44)$$

Particular solutions can be obtained for a given value of the summation indice  $\Lambda$ .

One can also search directly search solutions of Eq. (35) under the form:

$$u(x, t, k) = A \operatorname{sech} [k(x - v t)] + B \tanh [k(x - v t)] \quad (45)$$

which leads, at the  $j^{th}$  node, and time step  $n$ :

$$\begin{aligned} A(\sigma + 1) \operatorname{sech} \left( \frac{k \tau (j h - n v \sigma - 1)}{\sigma} \right) - (\sigma - 1) \operatorname{sech} \left( \frac{k \tau (j h - n v \sigma + 1)}{\sigma} \right) &\left( A + B \sinh \left( \frac{k \tau (j h - n v \sigma + 1)}{\sigma} \right) \right) \\ + B(\sigma + 1) \tanh \left( \frac{k \tau (j h - n v \sigma - 1)}{\sigma} \right) &= 0 \end{aligned} \quad (46)$$

## Spurious lattice solitons

which is satisfied for:

$$A = -B \sinh \left( k \left( \frac{(j \pm 1) h}{\sigma} - n v \tau \right) \right) \quad (47)$$

where  $B$ ,  $k$ ,  $v$  can take any values in  $\mathbb{R}$ .

It thus exhibits the existence of lattice solitons, related to the discrete numerical scheme, of the form

$$u_j^n = -B \sinh \left( k \left( \frac{(j \pm 1) h}{\sigma} - n v_j \tau \right) \right) \operatorname{sech} [k (j h - n v_j \tau)] + B \tanh [k (i h - n v_j \tau)] \quad , \quad (B, k, v_j) \in \mathbb{R}^3 \quad (48)$$

In the specific case where  $\sigma = 1$ , one obtains:

$$\operatorname{sech}(k \tau (j - n v_j - 1))(A + B \sinh(k \tau (j - n v_j - 1))) = 0 \quad (49)$$

1. For  $A = 0$ ,  $v_j = 1$ , one has:

$$j = n - 1 \quad (50)$$

which occurs on the recursive calculation of the approximate solution.

It thus exhibits the existence of lattice solitons, related to the discrete numerical scheme, of the form

$$u_j = B \tanh [k (j h - (j + 1) \tau)] \quad (51)$$

2. More generally, numerical simulations usually dealing with values of the time step number  $n \gg 1$ , for  $A = 0$ ,  $v = \frac{1}{p}$ ,  $p \in \mathbb{N}^*$ , the solitary wave dispersion relation is satisfied when

$$n = p (i - 1) \quad (52)$$

It thus also exhibits the existence of lattice solitons, related to the discrete numerical scheme, of the form

$$u_j = B \tanh [k (j h - p (i - 1) \tau)] \quad (53)$$

## Spurious lattice solitons

Also, when the time step number  $n$  goes towards infinity,  $\text{sech}(k \tau(j - n v - 1))$  tends towards zero, and the solitary wave dispersion relation (46) tends to be satisfied, accounting for the scheme to become numerically instable.

Figures 1, 2 respectively display a lattice solitary wave, first, for  $\sigma = 0.7$ ,  $h = 0.01$ ,  $v = 5$ ,  $k = 5$ , as a function of the mesh points, and, second, as a function of the  $cfl$  number  $\sigma$  and of the wave velocity  $v$ .

As expected, it can be noted that the solitary wave begins to become greatly unstable as the  $cfl$  number tends towards 1.

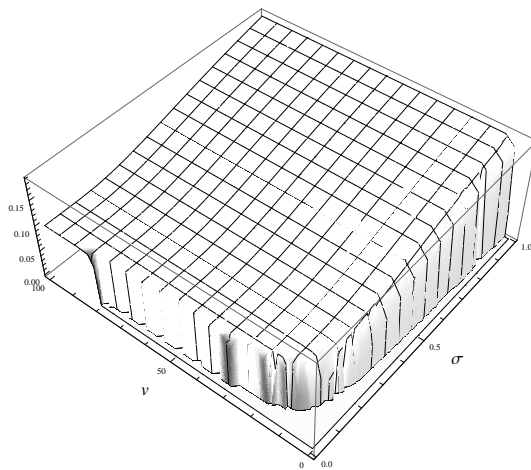

**Figure 1:**

A "lattice solitary wave", in the case of the Lax scheme, as a function of the mesh points, for  $\sigma = 0.7$ ,  $h = 0.01$ ,  $v = 5$ ,  $k = 5$

## 4 Concluding remarks

The existence of spurious numerical lattice solitary waves in linear advection schemes has been proved. Such lattice solitary waves, which are not solutions of the exact continuous original equation, nevertheless satisfy the numerical

## Spurious lattice solitons

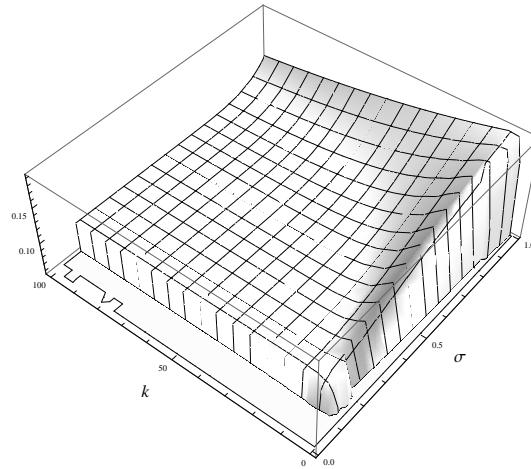

**Figure 2:**

A "lattice solitary wave", in the case of the Lax scheme, as a function of the cfl number  $\sigma$  and of the wave velocity  $v$

scheme, appearing as parasitic solutions of the correct one. Such spurious solitary waves have constant energy, and therefore the numerical error norm does not vanish at arbitrary long integration time on unbounded numerical domains.

## Thanks

The author would like to thank Tingwen Huang for his useful remarks.

## References

- [1] C. Hirsch, *Numerical Computation of Internal and External Flows*, Wiley-Interscience, 1988).
- [2] B.P. Leonard, A.P. Lock, M.K. Macvean, *The NIRVANA scheme applied to one-dimensional advection*, Int. J. Num. Meth. Heat Fluid Flow 5, 1995, 341-377.

## Spurious lattice solitons

- [3] B.P. Leonard, A.P. Lock, M.K. Macvean, *Conservative explicit unrestricted-time-step multidimensional constancy-preserving advection schemes*, Monthly Weather Review 124, 1996, 2588-2606.
- [4] H. Lomax, T.H. Pulliam, D.W. Zingg, *Fundamentals of Computational Fluid Dynamics*, Springer (2002).
- [5] T.K. Sengupta, *Fundamentals of Computational Fluid Dynamics*, Hyderabad Univ. Press, 2004.
- [6] T.K. Sengupta, A. Dipankar, *A comparative study of time advancement methods for solving Navier-Stokes equations*, J. Sci. Comput. 21, 2004, no. 2, 225-250.
- [7] T.K. Sengupta, S.K. Sircar, A. Dipankar, *High accuracy schemes for DNS and acoustics*, J. Sci. Comput. 26(2), 2006, 151-193.
- [8] T.K. Sengupta, A. Dipankar, P. Sagaut, *A Fourier-Laplace spectral theory of computing for non-periodic problems: signal and error propagation dynamics*. Submitted
- [9] Cl. David, P. Sagaut, T. Sengupta, *A linear dispersive mechanism for numerical error growth: spurious caustics*, European Journal of Fluid Mechanics-B/Fluids, **28** (1), 2009, 146-151.
- [10] Cl. David, P. Sagaut, *Structural stability of finite dispersion-relation preserving schemes*, Chaos, Solitons and Fractals, **41** (4), 2009, 2193-2199.
- [11] Cl. David, P. Sagaut, *Spurious solitons and structural stability of finite difference schemes for nonlinear wave equations*, Chaos, Solitons and Fractals, **41** (2), 2009, 655-660.
- [12] R.B. Pember, *Numerical methods for hyperbolic conservation laws with stiff relaxation I. Spurious solutions*, SIAM J. Appl. Math. 53, 1993, 1293-1330.
- [13] R. Vichnevsky and A.W. Tomalesky, *Spurious error waves in numerical approximations of hyperbolic equations*, Proc. 5th Princeton Conf. Information Science and Systems, 1971, 357.
- [14] R. Vichnevsky and B. Peiffer, *Error waves in finite element and finite difference methods for hyperbolic equations*, in: R. Vichnevsky, ed., *Advances in Comput. Meths. for PDE* (Publ. AICA, Rutgers Univ.), 1975, 53-58.
- [15] R. Vichnevetsky, J.B. Bowles, *Fourier Analysis of Numerical Approximations of Hyperbolic Equations*, SIAM Stud. Appl. Math. 5, 1982.



## Spurious lattice solitons

- [16] A. A. Craik, *Wave interactions and fluid flows*, Cambridge University Press, Cambridge, U.K., 1985.
- [17] C. Radhakrishnan, *The myth about nonlinear differential equations*, arXiv:nlin/0206048v2 [nlin.PS], 2000.
- [18] S.-D. Liu, Z.-T. Fu, S.-K. Liu, G.-J. Xin, F.-M. Liang, B.-Y. Feng, *Solitary Wave in Linear ODE with Variable Coefficients*, Commun. Theor. Phys. (Beijing, China) 39, 2003, 643-646.
- [19] J. C. Eilbeck, P. S. Lomdahl, and A. C. Scott. The discrete self-trapping equation. *Physica D*, 16, 1985, 318-338.
- [20] J. C. Eilbeck and A. C. Scott. Theory and applications of the discrete self-trapping equation. In P. L. Christiansen and R. D. Parmentier, editors, *Structure, Coherence, and Chaos in Dynamical Systems*, Manchester University Press, 1989, 139-159.
- [21] L. D. Faddeev and L. A. Takhtajan. *Hamiltonian methods in the theory of solitons*. Springer-Verlag, Berlin, 1987.
- [22] Davydovs Soliton Revisited. Self Trapping of Vibrational Energy in Proteins, edited by P.L. Christiansen, A.C. Scott, NATO ASI Series B 243 (Plenum Press, New York, 1990).
- [23] L. Cruzeiro-Hansson, H. Feddersen, R. Flesch, P.L. Christiansen, M. Salerno, A.C. Scott, *Phys. Rev. B* 42, 1990, 522.
- [24] E. Arévalo, Solitary wave solutions as a signature of the instability in the discrete nonlinear Schrödinger equation, *Physics Letters A* 373, 2009, 35413546.
- [25] Z. Feng and G. Chen, *Solitary Wave Solutions of the Compound Burgers-Korteweg-de Vries Equation*, *Physica A*, 352, 2005, 419-435.
- [26] Cl. David, R. Fernando, Z. Feng, *A note on "general solitary wave solutions of the Compound Burgers-Korteweg-de Vries Equation"*, *Physica A: Statistical and Theoretical Physics*, 375 (1), 2007, 44-50.
- [27] W. Magnus and S. Winkler, *Hill's Equation*, Courier Dover, 2004, p. 11.
- [28] G.B. Witham, *Linear and Nonlinear Wave*, Wiley-Interscience, 1974.