



**HAL**  
open science

# New counterexamples to the cell formula in nonconvex homogenization

Marco Barchiesi, Antoine Gloria

► **To cite this version:**

Marco Barchiesi, Antoine Gloria. New counterexamples to the cell formula in nonconvex homogenization. *Archive for Rational Mechanics and Analysis*, 2010, 195, pp.991-1204. 10.1007/s00205-009-0226-9 . hal-00767100

**HAL Id: hal-00767100**

**<https://hal.science/hal-00767100>**

Submitted on 20 Dec 2012

**HAL** is a multi-disciplinary open access archive for the deposit and dissemination of scientific research documents, whether they are published or not. The documents may come from teaching and research institutions in France or abroad, or from public or private research centers.

L'archive ouverte pluridisciplinaire **HAL**, est destinée au dépôt et à la diffusion de documents scientifiques de niveau recherche, publiés ou non, émanant des établissements d'enseignement et de recherche français ou étrangers, des laboratoires publics ou privés.

# NEW COUNTEREXAMPLES TO THE CELL FORMULA IN NONCONVEX HOMOGENIZATION

MARCO BARCHIESI & ANTOINE GLORIA

**Abstract.** In this article we show that for the homogenization of multiple integrals, the quasiconvexification of the cell formula is different from the asymptotic formula in general. To this aim, we construct three examples in three different settings: the homogenization of a discrete model, the homogenization of a composite material and the homogenization of a homogeneous material on a perforated domain.

**Keywords:** homogenization, quasiconvexity, cell formula

**2000 Mathematics Subject Classification:** 35B27, 49J45, 73B27, 74E30, 74Q05.

## CONTENTS

1. Introduction	1
2. Homogenization of multiple integrals and the cell formula	3
2.1. Continuous and discrete homogenization of nonconvex functionals	3
2.2. Short summary of convexity properties	5
2.3. Stefan Müller's counterexample	9
2.4. Counterexample by comparison of the zero levelsets	11
3. Counterexamples from composite materials	11
3.1. Discrete example	12
3.2. An example from solid-solid phase transformations	15
3.3. Comparison of both examples	18
4. Counterexample on perforated domains	18
Appendix: Stefan Müller's example in dimension three	25
References	29

## 1. INTRODUCTION

For the homogenization of periodic integral functionals of the type

$$I_\varepsilon(u) := \int_{\Omega \cap \varepsilon P} W\left(\frac{x}{\varepsilon}, \nabla u(x)\right) dx,$$

with suitable assumptions (recalled in Section 2.1), the  $\Gamma$ -limit writes

$$I_{\text{hom}}(u) := \int_{\Omega} W_{\text{hom}}(\nabla u(x)) dx,$$

where  $W_{\text{hom}}$  is obtained by an asymptotic formula on the number of periodic cells considered. If the integrand  $W(x, \cdot)$  happens to be convex almost everywhere, then the

---

*Date:* November 25, 2008.

asymptotic formula reduces to a minimization problem on the unitary cell with periodic boundary conditions, that we denote by  $W_{\text{cell}}$ . A counterexample due to Stefan Müller in [13] shows that in general, for quasiconvex nonconvex energy densities, the inequality  $W_{\text{cell}} \geq W_{\text{hom}}$  can be strict. More recently, Jean-François Babadjian and the first author gave another such example in [4].

As will be made precise in Section 2 for both examples, the energy density  $W_{\text{cell}}$  is not rank-one convex. In addition, in both cases, considering the quasiconvex envelop  $\mathcal{Q}W_{\text{cell}}$  of  $W_{\text{cell}}$  *surprisingly* removes the contradiction which allows to conclude that  $W_{\text{cell}} > W_{\text{hom}}$ . Hence, none of the known examples shows that the inequality  $\mathcal{Q}W_{\text{cell}} \geq W_{\text{hom}}$  can be strict, although this is to be expected.

The aim of this paper is twofold: to show that the known counterexamples to the cell formula are not rigid enough to prove that  $\mathcal{Q}W_{\text{cell}} > W_{\text{hom}}$ , and then to provide some new examples for which the latter strict inequality can be shown. The article is organized as follows. In Section 2, we recall standard results on homogenization as well as the two counterexamples to the cell formula mentioned above. We then show for each example that the methods used by their respective authors to prove the disagreement of  $W_{\text{cell}}$  with  $W_{\text{hom}}$  fail to prove the disagreement of  $\mathcal{Q}W_{\text{cell}}$  with  $W_{\text{hom}}$ . The rest of the paper is then dedicated to the construction of three different examples for which there exists a deformation gradient  $\Lambda$  such that  $\mathcal{Q}W_{\text{cell}}(\Lambda) > W_{\text{hom}}(\Lambda)$ . The examples are built in dimension two and they are based on the fact that replacing  $(0, 1)^2$ -periodicity by  $(0, 2)^2$ -periodicity is enough to relax significantly the energy to obtain the desired strict inequality. The first example is a discrete example where the keyrole is played by the very strong rigidity of discrete gradients. The second example is based on the same geometry but is written in a continuous setting and exploits the rigidity of the incompatible two-well problem together with an interplay between the geometry, the periodicity and the zero levelset of the energy densities. These examples are presented in Section 3. The last example is the object of Section 4. It relies on the homogenization of a homogeneous material on a perforated domain, for which we prove that the zero levelset of  $W_{\text{cell}}$  is contained in a quasiconvex set which is strictly contained in the zero levelset of  $W_{\text{hom}}$ . This is in particular the first example which shows the disagreement of  $W_{\text{cell}}$  and  $W_{\text{hom}}$  (as well as  $\mathcal{Q}W_{\text{cell}}$  and  $W_{\text{hom}}$ ) for the homogenization of a homogeneous material on a perforated domain.

Although the main result of this article is technical, we believe the examples are of independent interest. We therefore provide the non-specialist reader with the required background on convexity properties in Section 2.2.

Throughout the paper, we employ the following notation:

- $\Omega$  is a bounded open subset of  $\mathbb{R}^d$ ;
- $Q = (0, 1)^d$  denotes the unit cell;
- $Q_n = (0, n)^d$  for all  $n \in \mathbb{N}$ ;
- $Q^m = m + Q$  for all  $m \in \mathbb{Z}^d$ ;
- $\chi_U$  is the characteristic function of a subset  $U$  of  $\mathbb{R}^d$ ;
- $\mathbb{M}^d$  is the set of  $d \times d$  real matrices;
- $\mathbb{M}_{\text{sym}}^d$  is the set of  $d \times d$  symmetric real matrices;
- $SO_d$  is the family of the elements  $\Lambda$  of  $\mathbb{M}^d$  such that  $\det \Lambda = 1$  and  $\Lambda^T \Lambda = \mathbb{I}$ , where  $\mathbb{I} \in \mathbb{M}^d$  is the identity matrix;

- $|\Lambda| := \sqrt{\text{trace}(\Lambda^T \Lambda)}$  is the Frobenius norm of a matrix  $\Lambda \in \mathbb{M}^d$ ;
- $\mathcal{L}^n$  denotes the  $n$ -dimensional Lebesgue measure;
- $W_{\text{per}}^{1,p}(Q_n, \mathbb{R}^d)$  is the space of  $W_{\text{loc}}^{1,p}(\mathbb{R}^d, \mathbb{R}^d)$  functions which are  $Q_n$ -periodic;
- As a general rule,  $c$  denotes a constant which may vary from line to line but which is independent of the variables left.

## 2. HOMOGENIZATION OF MULTIPLE INTEGRALS AND THE CELL FORMULA

**2.1. Continuous and discrete homogenization of nonconvex functionals.** In this section, we recall classical results of periodic homogenization of multiple integrals, as well as (less) classical results of periodic homogenization of discrete systems. We refer the reader to the monograph [8] for continuous homogenization and to the article [1] for discrete homogenization.

**Definition 1.** Let  $\mathcal{U}$  be a normed space. We say that  $I : \mathcal{U} \rightarrow [-\infty, +\infty]$  is the  $\Gamma$ -limit of a sequence  $I_h : \mathcal{U} \rightarrow [-\infty, +\infty]$ , or that  $I_h$   $\Gamma$ -converges to  $I$ , if for every  $u \in \mathcal{U}$  the following conditions are satisfied:

- i) *Liminf inequality*: for every sequence  $u_h$  in  $\mathcal{U}$  such that  $u_h \rightarrow u$ ,

$$I(u) \leq \liminf_{h \rightarrow +\infty} I_h(u_h);$$

- ii) *Recovery sequence*: there exists a sequence  $u_h$  in  $\mathcal{U}$  such that  $u_h \rightarrow u$  and

$$I(u) = \lim_{h \rightarrow +\infty} I_h(u_h).$$

Let  $d \in \mathbb{N}$ . We focus on  $\Gamma$ -convergence of integral functionals on the normed space  $L^p(\Omega, \mathbb{R}^d)$ ,  $p \in (1, +\infty)$ , in the context of periodic homogenization.

Let  $a > 0$ . We denote by  $\mathcal{W}(a, p)$  the set of all continuous functions  $W : \mathbb{M}^d \rightarrow [0, +\infty)$  satisfying the following coerciveness and growth conditions of order  $p$ :

$$\frac{1}{a} |\Lambda|^p - a \leq \mathcal{W}(\Lambda) \leq a(1 + |\Lambda|^p) \quad \text{for all } \Lambda \in \mathbb{M}^d. \quad (2.1)$$

**Hypothesis 1.**  $W : \mathbb{R}^d \times \mathbb{M}^d \rightarrow [0, +\infty)$  is a Carathéodory function  $Q$ -periodic in the first variable such that  $W(x, \cdot) \in \mathcal{W}(a, p)$  for a.e  $x \in Q$ .

**Hypothesis 2.**  $P$  is a  $Q$ -periodic and open subset of  $\mathbb{R}^d$  with Lipschitz boundary such that  $Q \setminus P \subset\subset Q$ . Note that in particular  $P$  is connected.

Under Hypotheses 1 and 2, we consider for any  $\varepsilon > 0$  the functional  $I_\varepsilon : L^p(\Omega, \mathbb{R}^d) \rightarrow [0, +\infty]$  defined by

$$I_\varepsilon(u) := \begin{cases} \int_{\Omega \cap \varepsilon P} W\left(\frac{x}{\varepsilon}, \nabla u(x)\right) dx & \text{if } u|_{\Omega \cap \varepsilon P} \in W^{1,p}(\Omega \cap \varepsilon P, \mathbb{R}^d), \\ +\infty & \text{otherwise.} \end{cases}$$

**Definition 2.** We call *cell integrand* related to  $(W, P)$  the function  $W_{\text{cell}} : \mathbb{M}^d \rightarrow [0, +\infty)$  defined by

$$W_{\text{cell}}(\Lambda) := \inf \left\{ \int_{Q \cap P} W(x, \Lambda + \nabla \phi(x)) dx : \phi \in W_{\text{per}}^{1,p}(Q, \mathbb{R}^d) \right\}. \quad (2.2)$$

If  $P = \mathbb{R}^d$  we simply say that  $W_{\text{cell}}$  is the cell integrand related to  $W$ .

We call *homogenized integrand* related to  $(W, P)$  the function  $W_{\text{hom}} : \mathbb{M}^d \rightarrow [0, +\infty)$  defined by

$$W_{\text{hom}}(\Lambda) := \lim_{n \rightarrow \infty} \frac{1}{n^d} \inf \left\{ \int_{Q_n \cap P} W(x, \Lambda + \nabla \phi(x)) dx : \phi \in W_{\text{per}}^{1,p}(Q_n, \mathbb{R}^d) \right\}.$$

If  $P = \mathbb{R}^d$  we simply say that  $W_{\text{hom}}$  is the homogenized integrand related to  $W$ .

The following theorem is a standard result (See [8, Theorem 19.1 and Remark 19.2]).

**Theorem 1.** *Assume that  $W$  satisfies Hypothesis 1 and that  $P$  satisfies Hypothesis 2. Then the homogenized integrand  $W_{\text{hom}}$  related to  $(W, P)$  is a quasiconvex function belonging to  $\mathcal{W}(b, \Omega)$  for a suitable  $b = b(a, \Omega)$ , and for any  $\varepsilon_h \searrow 0^+$  the sequence  $I_{\varepsilon_h}$   $\Gamma$ -converges to the functional  $I_{\text{hom}} : L^p(\Omega, \mathbb{R}^d) \rightarrow [0, +\infty]$  defined by*

$$I_{\text{hom}}(u) := \begin{cases} \int_{\Omega} W_{\text{hom}}(\nabla u(x)) dx & \text{if } u \in W^{1,p}(\Omega, \mathbb{R}^d), \\ +\infty & \text{otherwise.} \end{cases}$$

*In addition, if  $W(x, \cdot)$  is convex for a.e.  $x \in Q$ , then  $W_{\text{hom}}$  is also convex and coincides with the cell integrand  $W_{\text{cell}}$  related to  $(W, P)$ .*

A result similar to Theorem 1 holds in a discrete setting, as shown in [1]. We give here a simpler version, for which we only consider nearest-neighbors interactions. We also need to slightly extend the result in [1] to take into account volumetric effects, which we will need in Section 3. Yet, the result remains essentially the same as announced in [2], and further details will be given in [3].

**Definition 3.** Let  $\mathcal{T}$  be a  $Q$ -periodic triangulation of  $\mathbb{R}^d$  and  $\mathcal{P}$  be the set of vertices of  $\mathcal{T}$ . We define the couples of nearest neighbors by

$$\mathcal{NN} := \{(x, y) \in (\mathcal{P} \cap \overline{Q})^2 : \exists T \in \mathcal{T} \text{ having } [x, y] \text{ as an edge}\}.$$

For all  $\varepsilon > 0$  and for all bounded open subset  $U$  of  $\mathbb{R}^d$ , we define

$$\mathcal{S}_{\varepsilon}(U, \mathbb{R}^d) := \{u \in C^0(U, \mathbb{R}^d) : u \text{ is affine on each element } T \in \varepsilon\mathcal{T} \cap U\}.$$

For  $\varepsilon = 1$ , we simply write  $\mathcal{S}(U, \mathbb{R}^d) = \mathcal{S}_{\varepsilon}(U, \mathbb{R}^d)$ . Moreover, we write

$$\mathcal{S}_{\text{per}}(Q_n, \mathbb{R}^d) := \{u \in \mathcal{S}(Q_n, \mathbb{R}^d) : u \text{ is } Q\text{-periodic}\}.$$

We are now in position to define energy functionals on discrete systems.

**Definition 4.** Let  $f_1 : Q \times Q \times \mathbb{R}^d \rightarrow [0, +\infty)$  and  $f_2 : Q \times \mathbb{R} \rightarrow [0, +\infty)$  be continuous functions and let  $\varepsilon > 0$ . For any bounded open subset  $U$  of  $\mathbb{R}^d$ , we define the energy of  $u \in \mathcal{S}_{\varepsilon}(U, \mathbb{R}^d)$  as

$$F_{\varepsilon}(u, U) := \sum_{m \in \mathbb{Z}^d : \varepsilon Q^m \subseteq U} F_{\varepsilon}^m(u),$$

(with the convention  $\sum_{\emptyset} = 0$ ) where, for any  $m \in \mathbb{Z}^d$  such that  $\varepsilon Q^m \subseteq U$ ,

$$F_{\varepsilon}^m(u) := \varepsilon^d \sum_{(x,y) \in \mathcal{NN}} f_1 \left( x, y, \frac{u(\varepsilon m + \varepsilon x) - u(\varepsilon m + \varepsilon y)}{\varepsilon |x - y|} \right) + \varepsilon^d \int_Q f_2(x, \det \nabla u(\varepsilon m + \varepsilon x)) dx.$$

If  $\varepsilon = 1$ , we simply write  $F(u, U) = F_\varepsilon(u, U)$ . Finally, we define the functional  $I_\varepsilon : L^p(\Omega, \mathbb{R}^d) \rightarrow [0, +\infty]$  by

$$I_\varepsilon(u) := \begin{cases} F_\varepsilon(u, \Omega) & \text{if } u \in S_\varepsilon(\Omega, \mathbb{R}^d), \\ +\infty & \text{otherwise.} \end{cases}$$

As for the continuous setting, we may define a cell integrand and a homogenized integrand as follows.

**Definition 5.** For all  $\Lambda \in \mathbb{M}^d$ , let  $\varphi_\Lambda : \mathbb{R}^d \rightarrow \mathbb{R}^d$  be given by  $\varphi_\Lambda(x) := \Lambda \cdot x$ . We call *cell integrand* related to  $(\mathcal{T}, F)$  the function  $W_{\text{cell}} : \mathbb{M}^d \rightarrow [0, +\infty)$  defined by

$$W_{\text{cell}}(\Lambda) := \inf\{F(\varphi_\Lambda + \phi, Q) : \phi \in \mathcal{S}_{\text{per}}(Q, \mathbb{R}^d)\}.$$

We call *homogenized integrand* related to  $(\mathcal{T}, F)$  the function  $W_{\text{hom}} : \mathbb{M}^d \rightarrow [0, +\infty)$  defined by

$$W_{\text{hom}}(\Lambda) := \lim_{n \rightarrow \infty} \frac{1}{n^d} \inf\{F(\varphi_\Lambda + \phi, Q_n) : \phi \in \mathcal{S}_{\text{per}}(Q_n, \mathbb{R}^d)\}.$$

We have the following result (see [1] and [3]).

**Theorem 2.** Let  $\mathcal{T}$ ,  $f_1$ ,  $f_2$ ,  $I_\varepsilon$  and  $W_{\text{hom}}$  be as in Definitions 3, 4, 5. Let us further assume that there exist  $a > 0$  and  $p \in (1, \infty)$  such that

$$\begin{aligned} 0 \leq f_2(x, z) &\leq a(1 + |z|^{p/d}) \quad \text{for all } (x, z) \in Q \times \mathbb{R}, \\ \frac{1}{a}|w|^p - a &\leq f_1(x, y, w) \leq a(1 + |w|^p) \quad \text{for all } (x, y, w) \in Q \times Q \times \mathbb{R}^d, \end{aligned}$$

Then the homogenized integrand  $W_{\text{hom}}$  associated to  $(\mathcal{T}, F)$  is a quasiconvex function satisfying a growth condition (2.1), and for any  $\varepsilon_h \searrow 0^+$  the sequence  $I_{\varepsilon_h}$   $\Gamma$ -converges to the functional  $I_{\text{hom}} : L^p(\Omega, \mathbb{R}^d) \rightarrow [0, +\infty]$  defined by

$$I_{\text{hom}}(u) := \begin{cases} \int_{\Omega} W_{\text{hom}}(\nabla u(x)) dx & \text{if } u \in W^{1,p}(\Omega, \mathbb{R}^d), \\ +\infty & \text{otherwise.} \end{cases}$$

In addition, if  $f_2 \equiv 0$  and if  $f_1(x, y, \cdot)$  is a convex function for all  $x, y \in Q$ , then  $W_{\text{hom}}$  is also convex and coincides with the cell integrand  $W_{\text{cell}}$  related to  $(\mathcal{T}, F)$ .

**2.2. Short summary of convexity properties.** In this section, we recall the notions of polyconvexity, quasiconvexity and rank-one convexity of functions and sets. We refer the reader to [9], [10], [14] for details. We also state and prove some elementary lemmas that will be used in the analysis of the counterexamples.

**Definition 6.** (quasiconvex function) A locally bounded and Borel measurable function  $W : \mathbb{M}^d \rightarrow \mathbb{R}$  is said to be *quasiconvex* if

$$W(\Lambda) := \inf \left\{ \int_Q W(\Lambda + \nabla \phi(x)) dx : \phi \in W_0^{1,\infty}(Q, \mathbb{R}^d) \right\}.$$

Given  $W : \mathbb{M}^d \rightarrow \mathbb{R}$  we define the *quasiconvex envelope* of  $W$  as

$$\mathcal{Q}W(\Lambda) := \sup\{V(\Lambda) \text{ such that } V \text{ is quasiconvex and } V \leq W\}$$

with the convention  $\sup \emptyset = -\infty$ . If  $\mathcal{Q}W \neq -\infty$ , then it is quasiconvex function. Moreover, if  $W$  is also locally bounded and Borel measurable, then

$$\mathcal{Q}W(\Lambda) = \inf \left\{ \int_U W(\Lambda + \nabla \phi(x)) dx : \phi \in W_0^{1,\infty}(U, \mathbb{R}^d) \right\}, \quad (2.3)$$

where  $U$  is any bounded open subset of  $\mathbb{R}^d$ . In particular, the infimum in the formula is independent of the choice of  $U$ . If  $U = Q$ , then  $W_0^{1,\infty}(Q, \mathbb{R}^d)$  can be replaced by  $W_{\text{per}}^{1,\infty}(Q, \mathbb{R}^d)$ .

**Lemma 1.** (main property) *Let  $W : \Omega \times \mathbb{M}^d \rightarrow [0, +\infty)$  be a Carathéodory function such that  $W(x, \cdot) \in \mathcal{W}(a, p)$  for a.e.  $x \in \Omega$  and let  $\mathcal{U}$  be a weakly closed subset of  $W^{1,p}(\Omega, \mathbb{R}^d)$ . Then*

$$\inf \left\{ \int_{\Omega} W(x, \nabla u(x)) dx : u \in \mathcal{U} \right\} = \min \left\{ \int_{\Omega} \mathcal{Q}W(x, \nabla u(x)) dx : u \in \mathcal{U} \right\} > -\infty,$$

and any weak limit of a minimizing sequence of the original problem is a minimizer of the relaxed problem.

**Remark 1.** Assume that  $P$  satisfies Hypothesis 2. Since  $Q \cap P$  has Lipschitz boundary, any function  $\varphi \in W^{1,p}(Q \cap P, \mathbb{R}^d)$  can be extended to a function  $\tilde{\varphi} \in W^{1,p}(Q, \mathbb{R}^d)$ . As a consequence,  $\{\phi|_{Q \cap P} : \phi \in W_{\text{per}}^{1,p}(Q, \mathbb{R}^d)\}$  is a weakly closed subset of  $W^{1,p}(Q \cap P, \mathbb{R}^d)$ .

**Definition 7.** (polyconvex function) For any matrix  $\Lambda \in \mathbb{M}^d$ , let denote by  $\mathbf{M}(\Lambda)$  the vector that consists of all minors of  $\Lambda$ , and denote by  $\delta(d)$  its length. We can identify  $\mathbf{M}(\Lambda)$  with a point of  $\mathbb{R}^{\delta(d)}$ . We say that a function  $W : \mathbb{M}^d \rightarrow \mathbb{R}$  is *polyconvex* if there exists a convex function  $g : \mathbb{R}^{\delta(d)} \rightarrow \mathbb{R}$  such that for all  $\Lambda \in \mathbb{M}^d$ ,

$$W(\Lambda) = g(\mathbf{M}(\Lambda)).$$

**Definition 8.** (rank-one convex function) We say that  $W : \mathbb{M}^d \rightarrow \mathbb{R}$  is *rank-one convex* if

$$W(tA + (1-t)B) \leq tW(A) + (1-t)W(B)$$

for all  $t \in [0, 1]$  and for all  $A, B \in \mathbb{M}^d$  rank-one connected, *i.e.*, such that  $\text{rank}(B - A) = 1$ . Given  $W : \mathbb{M}^d \rightarrow \mathbb{R}$  we define the *rank-one convex envelope* of  $W$  as

$$\mathcal{R}W(\Lambda) := \sup \{V(\Lambda) \text{ such that } V \text{ is rank-one convex and } V \leq W\}$$

with the convention  $\sup \emptyset = -\infty$ . If  $\mathcal{R}W \neq -\infty$ , then it is rank-one convex function.

**Lemma 2.** *Let  $W : \mathbb{M}^d \rightarrow \mathbb{R}$ , then there holds*

$$W \text{ is convex} \implies W \text{ is polyconvex} \implies W \text{ is quasiconvex} \implies W \text{ is rank-one convex.}$$

One can extend the notions of convexity, polyconvexity, quasiconvexity and rank-one convexity to sets.

**Definition 9.** (polyconvex, quasiconvex and rank-one convex sets) Let  $K$  be a compact subset of  $\mathbb{M}^d$ . We define the polyconvex hull  $K^{pc}$ , quasiconvex hull  $K^{qc}$  and rank-one convex hull  $K^{rc}$  of  $K$  by

$$K^{pc} := \{ \Lambda \in \mathbb{M}^d : f(\Lambda) = 0 \quad \forall f : \mathbb{M}^d \rightarrow [0, +\infty) \text{ polyconvex such that } f|_K \equiv 0 \},$$

$$K^{qc} := \{ \Lambda \in \mathbb{M}^d : f(\Lambda) = 0 \quad \forall f : \mathbb{M}^d \rightarrow [0, +\infty) \text{ quasiconvex such that } f|_K \equiv 0 \},$$

$$K^{rc} := \{ \Lambda \in \mathbb{M}^d : f(\Lambda) = 0 \quad \forall f : \mathbb{M}^d \rightarrow [0, +\infty) \text{ rank-one convex such that } f|_K \equiv 0 \}.$$

The set  $K$  is said to be polyconvex if  $K = K^{pc}$ , quasiconvex if  $K = K^{qc}$  and rank-one convex if  $K = K^{rc}$ . We have the inclusions  $K^{rc} \subseteq K^{qc} \subseteq K^{pc} \subseteq K^{co}$ , where the superscript  $co$  denotes the classical convex hull.

We have the following useful characterizations of  $K^{qc}$  and  $K^{pc}$ .

**Lemma 3.** ([14, Theorem 4.10]). *Given a compact set  $K \subseteq \mathbb{M}^d$ , a matrix  $A \in \mathbb{M}^d$  belongs to  $K^{qc}$  if and only if there exists a sequence  $\psi_h$  bounded in  $W^{1,\infty}(Q, \mathbb{R}^d)$  such that*

$$\begin{aligned} \text{dist}(\nabla\psi_h, K) &\rightarrow 0 \text{ in measure;} \\ \psi_h(x) &= A \cdot x \text{ for } x \in \partial Q. \end{aligned}$$

**Lemma 4.** ([12, Lemma 1]). *Given a compact set  $K \subseteq \mathbb{M}^d$ , a matrix  $A \in \mathbb{M}^d$  belongs to  $K^{pc}$  if and only if  $\mathbf{M}(A)$  lies in  $\{\mathbf{M}(\Lambda) : \Lambda \in K\}^{co}$ .*

The sets we will be interested in are the zero-levelsets of energy densities defined as follows.

**Definition 10.** Let  $W : \mathbb{M}^d \rightarrow [0, +\infty)$  be a continuous function, we define its zero levelset as

$$W^{-1}(0) = \{\Lambda \in \mathbb{M}^d : W(\Lambda) = 0\}.$$

In particular, if  $W$  is a quasiconvex function, then  $W^{-1}(0)$  is a quasiconvex set.

**Lemma 5.** *If  $W \in \mathcal{W}(a, p)$ , then*

$$\mathcal{Q}W^{-1}(0) = (W^{-1}(0))^{qc}.$$

*Proof.* Let  $K := W^{-1}(0)$ . The inclusion  $K^{qc} \subseteq \mathcal{Q}W^{-1}(0)$  is trivial and we only need to prove the opposite one. This proof makes use of Young measures, for which we refer the reader to [14] for a comprehensive treatment.

Let  $A \in \mathcal{Q}W^{-1}(0)$ . By formula (2.3), there exists  $\phi_h \in W_0^{1,\infty}(Q, \mathbb{R}^d)$  such that

$$0 = \mathcal{Q}W(A) = \lim_{h \rightarrow +\infty} \int_Q W(A + \nabla\phi_h(x)) dx.$$

As a consequence of the  $p$ -coercivity of  $W$  and Poincaré's inequality, the sequence  $\psi_h(x) := A \cdot x + \phi_h(x)$  is bounded in  $W^{1,p}(Q, \mathbb{R}^d)$ . Thus, up to extraction,  $\nabla\psi_h$  generates a Young measure  $\mu : Q \ni x \mapsto \mu_x \in \mathcal{P}(\mathbb{M}^d)$ , where  $\mathcal{P}(\mathbb{M}^d)$  denotes the family of probability measures on  $\mathbb{M}^d$ .

By the fundamental theorem on Young measures (see [14, Theorem 3.1]), we get

$$0 = \lim_{h \rightarrow +\infty} \int_Q W(A + \nabla\phi_h(x)) dx \geq \int_Q \left( \int_{\mathbb{M}^d} W(\Lambda) d\mu_x(\Lambda) \right) dx$$

and therefore by [6, Lemma 3.3]  $\text{supp}\mu_x \subseteq K$  for  $\mathcal{L}^d a.e.$   $x \in Q$ . Again by the fundamental theorem, this implies that

$$\text{dist}(\nabla\psi_h, K) \rightarrow 0 \text{ in measure.} \tag{2.4}$$

By using Zhang's lemma (see [14, Lemma 4.21]),  $\psi_h$  can be modified on small sets so that its gradient be bounded in  $L^\infty(Q, \mathbb{M}^d)$ , while keeping conditions (2.4) and  $\psi_h(x) = A \cdot x$  for  $x \in \partial Q$ . The thesis follows now by Lemma 3.  $\square$



We will also make use of the following results about the cell integrand.

**Lemma 6.** *Assume that  $W$  satisfies Hypothesis 1 and that  $P$  satisfies Hypothesis 2. Then the cell integrand  $W_{\text{cell}}$  related to  $(W, P)$  is a continuous function.*

*Proof.* This property is a direct consequence of the following inequality:

$$W_{\text{cell}}(\Lambda_1) \leq W_{\text{cell}}(\Lambda_2) + c(\Lambda_1, \Lambda_2)|\Lambda_1 - \Lambda_2| \quad \text{for all } \Lambda_1, \Lambda_2 \in \mathbb{M}^d, \quad (2.5)$$

where  $c(\Lambda_1, \Lambda_2)$  is locally uniformly bounded.

Let us prove inequality (2.5). By Lemma 1 and Remark 1, we have

$$W_{\text{cell}}(\Lambda) = \min \left\{ \int_{Q \cap P} \mathcal{Q}W(x, \Lambda + \nabla \phi(x)) dx : \phi \in W_{\text{per}}^{1,p}(Q, \mathbb{R}^d) \right\}. \quad (2.6)$$

Due to the growth condition from above satisfied by  $\mathcal{Q}W(x, \cdot)$ , there exists  $c > 0$  such that for every  $\Lambda_1, \Lambda_2 \in \mathbb{M}^d$ , there holds

$$|\mathcal{Q}W(x, \Lambda_1) - \mathcal{Q}W(x, \Lambda_2)| \leq c|\Lambda_1 - \Lambda_2|(1 + |\Lambda_1|^{p-1} + |\Lambda_2|^{p-1})$$

This property, which is classical for convex functions, holds for rank-one convex functions (see [11, Lemma 5.2]). Let now  $\Lambda_1, \Lambda_2 \in \mathbb{M}^d$ , and let  $\phi_1, \phi_2 \in W_{\text{per}}^{1,p}(Q, \mathbb{R}^d)$  be minimizers associated with  $\Lambda_1$  and  $\Lambda_2$  through (2.6). We then have

$$\begin{aligned} W_{\text{cell}}(\Lambda_1) - W_{\text{cell}}(\Lambda_2) &= \int_{Q \cap P} \mathcal{Q}W(x, \Lambda_1 + \nabla \phi_1(x)) - \mathcal{Q}W(x, \Lambda_2 + \nabla \phi_2(x)) dx \\ &\leq \int_{Q \cap P} \mathcal{Q}W(x, \Lambda_1 + \nabla \phi_2(x)) - \mathcal{Q}W(x, \Lambda_2 + \nabla \phi_2(x)) dx \\ &\leq \int_{Q \cap P} c|\Lambda_1 - \Lambda_2|(1 + |\Lambda_1|^{p-1} + |\Lambda_2|^{p-1} + |\Lambda_2 + \nabla \phi_2(x)|^{p-1}) dx. \end{aligned}$$

Using the coercivity of  $\mathcal{Q}W$  (lower bound in (2.1)), we may bound  $\|\Lambda_2 + \nabla \phi_2\|_{L^p}^p$  from above by the energy, which is less than  $c(1 + |\Lambda_2|^p)$  using the test function  $\phi \equiv 0$  and the upper bound of (2.1). Hence, there exists a constant  $c > 0$  such that the inequality

$$W_{\text{cell}}(\Lambda_1) - W_{\text{cell}}(\Lambda_2) \leq c|\Lambda_1 - \Lambda_2|(1 + |\Lambda_1|^{p-1} + |\Lambda_2|^{p-1}),$$

holds for any  $\Lambda_1, \Lambda_2 \in \mathbb{M}^d$ , which proves the claim.  $\square$

**Lemma 7.** *Let  $W \in \mathcal{W}(a, p)$  and let  $P$  satisfy Hypothesis 2. Assume in addition that  $W$  is quasiconvex, and that  $W^{-1}(0)$  is not empty. Then  $A \in \mathbb{M}^d$  belongs to the zero levelset of the cell integrand  $W_{\text{cell}}$  associated to  $(W, P)$  if and only if there exists a  $Q$ -periodic Lipschitz function  $\phi : \mathbb{R}^d \rightarrow \mathbb{R}^d$  satisfying*

$$A + \nabla \phi(x) \in W^{-1}(0) \quad \text{for a.e. } x \in Q \cap P.$$

*Proof.* The condition is obviously sufficient. By Lemma 1 and Remark 1, we have

$$W_{\text{cell}}(\Lambda) = \min \left\{ \int_{Q \cap P} W(\Lambda + \nabla \phi(x)) dx : \phi \in W_{\text{per}}^{1,p}(Q, \mathbb{R}^d) \right\}. \quad (2.7)$$

Let  $A \in W_{\text{cell}}^{-1}(0)$  and let  $\phi \in W_{\text{per}}^{1,p}(Q, \mathbb{R}^d)$  be a minimizer associated with  $A$  through (2.7). Then

$$W(A + \nabla \phi(x)) = 0 \quad \text{for a.e. } x \in Q \cap P.$$

Since  $W^{-1}(0)$  is compact and  $Q \cap P$  has a Lipschitz boundary, the function  $\phi|_{Q \cap P}$  has a Lipschitz representative. The conclusion follows by taking a Lipschitz  $Q$ -periodic extension of  $\phi|_{Q \cap P}$  on  $\mathbb{R}^d$ .  $\square$

A similar characterization of the levelset of the cell integrand holds in the case of mixtures.

**Lemma 8.** ([4, Lemma 4.4]). *Let  $W_1, W_2 \in \mathcal{W}(a, p)$  be two quasiconvex functions such that  $W_1^{-1}(0)$  and  $W_2^{-1}(0)$  are not empty. Given a measurable subset  $U$  of  $Q$ , let set  $W : \mathbb{R}^d \times \mathbb{M}^d \rightarrow [0, +\infty)$  as*

$$W(x, \Lambda) := \chi(x)W_1(\Lambda) + (1 - \chi(x))W_2(\Lambda),$$

where  $\chi$  is defined by  $\chi := \chi_U$  in  $Q$  and extended by periodicity to the whole  $\mathbb{R}^d$ . Then  $A \in \mathbb{M}^d$  belongs to the zero levelset of the cell integrand  $W_{\text{cell}}$  associated to  $W$  if and only if there exists a  $Q$ -periodic Lipschitz function  $\phi : \mathbb{R}^d \rightarrow \mathbb{R}^d$  satisfying

$$A + \nabla \phi(x) \in \begin{cases} W_1^{-1}(0) & \text{for a.e. } x \in U \\ W_2^{-1}(0) & \text{for a.e. } x \in Q \setminus U \end{cases}.$$

**Remark 2.** The previous lemma shows that in the case of a mixture of the type  $W = \chi W_1 + (1 - \chi)W_2$ , the zero levelset of  $W_{\text{cell}}$  depends only on the zero levelsets of  $W_1, W_2$  and not on their global shapes or growths. The same property can be proved for the zero levelset of  $W_{\text{hom}}$  (see [7, Theorem 1.3]). This fact is one of the keys of our counterexamples: we have to introduce suitable zero levelsets first, and only afterwards construct suitable functions.

**2.3. Stefan Müller's counterexample.** The energy under consideration  $W^\eta : \mathbb{R}^2 \times \mathbb{M}^2 \rightarrow [0, +\infty)$ ,  $(x, \Lambda) \mapsto \chi^\eta(x)W_0(\Lambda)$  models a two-dimensional laminate composite, made of a strong material and a soft material. The coefficient  $\chi^\eta$  is the  $Q$ -periodic extension on  $\mathbb{R}^2$  of

$$\chi^\eta(x) := \begin{cases} 1 & \text{if } x_1 \in (0, 1/2) \\ \eta & \text{if } x_1 \in [1/2, 1) \end{cases},$$

where  $Q \ni x = (x_1, x_2)$  and  $\eta > 0$ . The energy density  $W_0 : \mathbb{M}^2 \rightarrow [0, +\infty)$  is given by  $W_0(\Lambda) = |\Lambda|^4 + f(\det \Lambda)$  where

$$f(z) := \begin{cases} \frac{8(1+a)^2}{z+a} - 8(1+a) - 4 & \text{if } z > 0 \\ \frac{8(1+a)^2}{a} - 8(1+a) - 4 - \frac{8(1+a)^2}{a^2}z & \text{if } z \leq 0 \end{cases}$$

for some  $a \in (0, 1/2)$ .

In particular,  $W^\eta(x, \cdot)$  is a nonnegative polyconvex function satisfying a standard growth condition (2.1) of order  $p = 4$ . Its zero levelset is  $SO_2$  for all  $x \in Q$ .

We respectively denote by  $W_{\text{cell}}^\eta$  and  $W_{\text{hom}}^\eta$  the cell integrand and the homogenized integrand associated with  $W^\eta$ .

Using the one-well rigidity (Liouville theorem) on the unitary cell and using 'buckling-like' test-functions on several periodic cells (see Figure 2.3), Stefan Müller obtained the following result.

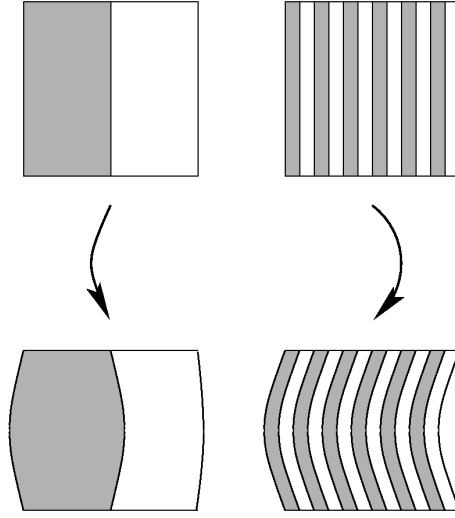

FIGURE 1. Compression of one periodic cell and buckling of several periodic cells

**Theorem 3.** [13, Theorem 4.3] *For all  $\lambda \in (\pi/4, 1)$ , there exist  $c_1, c_2 > 0$  independent of  $\eta$ , such that*

$$\begin{aligned} W_{\text{hom}}^\eta(\Lambda) &\leq \eta c_1 \\ W_{\text{cell}}^\eta(\Lambda) &\geq c_2, \end{aligned}$$

where  $\Lambda := \text{diag}(1, \lambda)$ , hence proving that the strict inequality  $W_{\text{cell}}^\eta(\Lambda) > W_{\text{hom}}^\eta(\Lambda)$  holds provided  $\eta$  is small enough.

However, in view of the following proposition, Theorem 3 does not allow to conclude whether the inequality  $\mathcal{Q}W_{\text{cell}}^\eta(\Lambda) \geq W_{\text{hom}}^\eta(\Lambda)$  may be strict or not. Note, in particular, that  $W_{\text{cell}}^\eta$  is not even a rank-one convex (and a fortiori not quasiconvex).

**Proposition 1.** *For all  $\lambda \in (0, 1)$ , there exists  $c > 0$  independent of  $\eta$  such that*

$$\mathcal{R}W_{\text{cell}}^\eta(\Lambda) \leq \eta c, \quad (2.8)$$

where  $\Lambda := \text{diag}(1, \lambda)$ .

*Proof.* Let  $\{\mathbf{e}_1, \mathbf{e}_2\}$  be the canonical basis in  $\mathbb{R}^2$ . Since, by Jensen's inequality,

$$\mathcal{R}W_{\text{cell}}^\eta(\Lambda) \leq \inf \left\{ \int_0^1 W_{\text{cell}}^\eta(\Lambda + \phi'(t)\mathbf{e}_1 \otimes \mathbf{e}_2) dt : \phi \in W_{\text{per}}^{1,\infty}((0, 1)) \right\}$$

it is enough to exhibit a test function  $\phi \in W_{\text{per}}^{1,\infty}((0, 1))$  such that the majoration in (2.8) holds. Let  $\phi \in W_{\text{per}}^{1,\infty}((0, 1))$  be such that

$$\phi'(t) = \bar{\chi}(t)\sqrt{1 - \lambda^2},$$

where  $\bar{\chi}$  is the  $(0, 1)$ -periodic extension on  $\mathbb{R}$  of

$$\bar{\chi}(t) := \begin{cases} 1 & \text{if } t \in (0, 1/2) \\ -1 & \text{if } t \in [1/2, 1) \end{cases}.$$

We also choose  $\varphi \in L^\infty((0, 1), W_{\text{per}}^{1,\infty}(Q, \mathbb{R}^2))$  such that

$$\nabla_y \varphi(t, y) = \bar{\chi}(y_1) \begin{pmatrix} \lambda - 1 & 0 \\ -\bar{\chi}(t)\sqrt{1-\lambda^2} & 0 \end{pmatrix},$$

Then, in the strong phase ( $\bar{\chi}(y_1) = 1$ ), the test function  $\Lambda + \phi'(t)\mathbf{e}_1 \otimes \mathbf{e}_2 + \nabla_y \varphi(t, y)$  is the rotation

$$\begin{pmatrix} \lambda & \pm\sqrt{1-\lambda^2} \\ \mp\sqrt{1-\lambda^2} & \lambda \end{pmatrix},$$

and, in the soft phase ( $\bar{\chi}(y_1) = -1$ ), the deformation gradient is of the form

$$A := \begin{pmatrix} 2 - \lambda & \pm\sqrt{1-\lambda^2} \\ \pm\sqrt{1-\lambda^2} & \lambda \end{pmatrix}. \quad (2.9)$$

Hence,

$$\mathcal{R}W_{\text{cell}}^\eta(\Lambda) \leq \int_0^1 \int_Q W^\eta(y, \Lambda + \phi'(t)\mathbf{e}_1 \otimes \mathbf{e}_2 + \nabla_y \varphi(t, y)) dy dt \leq \frac{1}{2}\eta W_0(A),$$

for some  $A$  of the form (2.9).  $\square$

**Remark 3.** As shown in the Appendix, Proposition 1 holds in dimension three in a weaker form, by substituting the rank-one convex hull with the quasiconvex hull of  $W_{\text{cell}}^\eta$ .

**2.4. Counterexample by comparison of the zero levelsets.** Let us consider the following matrices of  $\mathbb{M}^2$

$$\mathbb{O} := \text{diag}(0, 0), \quad \mathbb{I} := \text{diag}(1, 1), \quad A := \text{diag}(-1, 1), \quad B := \text{diag}(0, 1), \quad \text{and } C := \text{diag}(0, 1/2),$$

and two quasiconvex functions  $W_1, W_2 \in \mathcal{W}(a, p)$  such that

$$W_1^{-1}(0) = \{\mathbb{O}, A\} \quad \text{and} \quad W_2^{-1}(0) = \{\mathbb{O}, \mathbb{I}\}.$$

We define  $W : \mathbb{R}^2 \times \mathbb{M}^2 \rightarrow [0, \infty)$  by

$$W(x, \Lambda) := \chi(x)W_1(\Lambda) + (1 - \chi(x))W_2(\Lambda),$$

where  $\chi$  is given by  $\chi := \chi_{(0,1/2) \times (0,1)}$  in  $Q$  and extended by periodicity to the whole  $\mathbb{R}^2$ .

Then, Jean-François Babadjian and the first author proved in [4, Example 6.1] that  $W_{\text{cell}}(\mathbb{I}) = W_{\text{cell}}(B) = W_{\text{hom}}(\mathbb{I}) = W_{\text{hom}}(B) = 0$  and  $W_{\text{cell}}(C) > 0$ . Since  $C \in \{\mathbb{O}, B\}^{rc}$  and  $W_{\text{hom}}$  is rank-one convex, this implies that  $W_{\text{hom}}(C) = 0 < W_{\text{cell}}(C)$ . However, one also has  $\mathcal{R}W_{\text{cell}}(C) = 0$ .

### 3. COUNTEREXAMPLES FROM COMPOSITE MATERIALS

In this section, we propose two examples for which  $\mathcal{Q}W_{\text{cell}}(\Lambda) > W_{\text{hom}}(\Lambda)$  for some  $\Lambda \in \mathbb{M}^2$ . The first one relies on the rigidity of periodic discrete gradients, whereas the second example uses the rigidity of the incompatible two-well problem together with the periodicity constraint. Both examples are based on the same geometry (see Figures 2 and 4).

**3.1. Discrete example.** Let us first describe the geometry of the model.

**Geometry.** The triangulation  $\mathcal{T}$  of  $\mathbb{R}^2$  is the  $Q$ -periodic replication of the triangulation  $\{T_1, \dots, T_8\}$  of  $Q$  (see the numerotation of Figure 2) defined as follows.

$$\begin{aligned} T_1 &:= \{x \in Q : x_2 \geq x_1 + 1/2\}, & T_5 &:= T_4 - (1/2, -1/2), \\ T_3 &:= \{x \in Q : x_2 \leq -x_1 + 1/2\}, & T_6 &:= T_3 + (1/2, 1/2), \\ T_2 &:= \{x \in Q : x_2 \geq -x_1 + 3/2\}, & T_7 &:= T_2 - (1/2, 1/2), \\ T_4 &:= \{x \in Q : x_2 \leq x_1 - 1/2\}, & T_8 &:= T_1 + (1/2, -1/2). \end{aligned} \quad (3.1)$$

We will make use of the following notation: for all  $n \in \mathbb{N}$ ,  $\mathcal{T}_n$  denotes the restriction of  $\mathcal{T}$  to  $Q_n$ , while for all  $m \in \mathbb{Z}^2$  and  $\tau \in \{1, \dots, 8\}$ ,  $T_\tau^m = T_\tau + m$ . Moreover, for  $i \in \{1, 2, 3\}$ , we denote by  $x_{\tau,i}^m$  the  $i^{\text{th}}$  vertex of the triangle  $T_\tau^m$  and we set  $\mathcal{N}_\tau^m := \{x_{\tau,1}^m, x_{\tau,2}^m, x_{\tau,3}^m\}$ . For the vertices in  $\partial Q$  we use a simpler notation:  $y^1 := (0, 1/2)$ ,  $y^2 := (1/2, 0)$ ,  $y^3 := (1, 1/2)$ ,  $y^4 := (1/2, 1)$ ,  $y^5 := (0, 1)$ ,  $y^6 := (0, 0)$ ,  $y^7 := (1, 0)$ , and  $y^8 := (1, 1)$ .

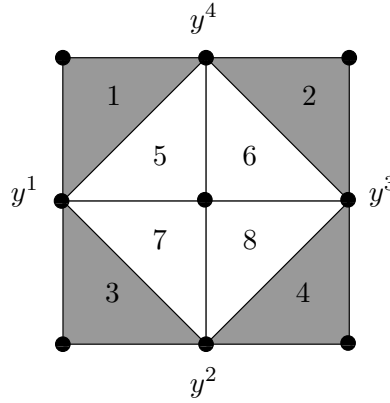

FIGURE 2. Geometry.

**Energy.** Let  $U$  be a bounded open subset of  $\mathbb{R}^2$ . Given  $u \in \mathcal{S}(U, \mathbb{R}^2)$ ,  $m \in \mathbb{Z}^2$ ,  $\tau \in \{1, \dots, 8\}$ , and  $i \in \{1, 2, 3\}$ , if  $U \cap T_\tau^m \neq \emptyset$  and  $x_{\tau,i}^m \in U$ , we set

$$\begin{aligned} \nabla u_\tau^m &:= \nabla u|_{T_\tau^m} \text{ (which is constant on } T_\tau^m) \\ u_{\tau,i}^m &:= u(x_{\tau,i}^m). \end{aligned}$$

Let  $f_1, f_2 : \mathbb{R}^2 \rightarrow [0, +\infty)$  be defined by

$$\begin{aligned} f_1(z) &:= (z^2 - 1)^2 \\ f_2(z) &:= (z - 1)^2. \end{aligned}$$

As in Definition 4, for all  $\eta > 0$  we consider the energy

$$F^\eta(u, U) := \sum_{m \in \mathbb{Z}^2 : Q^m \subseteq U} F^{\eta,m}(u),$$

where, for any  $m \in \mathbb{Z}^2$  such that  $Q^m \subseteq U$ ,

$$F^{\eta,m}(u) := \sum_{\tau=1}^4 \left[ \frac{1}{8} f_2(\det \nabla u_\tau^m) + \sum_{i,j \in \mathcal{N}_\tau^m, i < j} \frac{\eta}{2} f_1 \left( \frac{|u_{\tau,i}^m - u_{\tau,j}^m|}{|x_{\tau,i}^m - x_{\tau,j}^m|} \right) \right] \\ + \sum_{\tau=5}^8 \left[ \frac{\eta}{8} f_2(\det \nabla u_\tau^m) + \sum_{i,j \in \mathcal{N}_\tau^m, i < j} \frac{\eta}{2} f_1 \left( \frac{|u_{\tau,i}^m - u_{\tau,j}^m|}{|x_{\tau,i}^m - x_{\tau,j}^m|} \right) \right].$$

The model satisfies the assumptions of Theorem 2. We respectively denote by  $W_{\text{cell}}^\eta$  and  $W_{\text{hom}}^\eta$  the cell integrand and the homogenized integrand associated with  $(\mathcal{T}, F^\eta)$ .

**Theorem 4.** *For all  $\lambda > 1$  and  $\eta > 0$  the following properties hold*

- 1)  $\mathcal{Q}W_{\text{cell}}^\eta(\lambda\mathbb{I})$  is bounded from below by  $(\lambda^2 - 1)^2/2$ ;
- 2) there exists  $c > 0$  independent of  $\eta$  such that  $W_{\text{hom}}^\eta(\lambda\mathbb{I}) \leq \eta c$ .

Therefore the strict inequality  $\mathcal{Q}W_{\text{cell}}^\eta(\lambda\mathbb{I}) > W_{\text{hom}}^\eta(\lambda\mathbb{I})$  holds provided  $\eta$  is small enough.

*Proof.*

**Property 1).** For all  $\eta > 0$ , let consider the energy

$$\tilde{F}^\eta(u, U) := \sum_{m \in \mathbb{Z}^2 : Q^m \subseteq U} \tilde{F}^{\eta,m}(u),$$

where, for any  $m \in \mathbb{Z}^2$  such that  $Q^m \subseteq U$ ,

$$\tilde{F}^{\eta,m}(u) := \sum_{\tau=1}^4 \frac{1}{8} f_2(\det \nabla u_\tau) + \sum_{\tau=5}^8 \frac{\eta}{8} f_2(\det \nabla u_\tau).$$

Let  $\widetilde{W}_{\text{cell}}^\eta$  be the cell integrand associated with  $(\mathcal{T}, \tilde{F}^\eta)$ . Since we have neglected the contributions of the terms involving  $f_1$ , we have  $W_{\text{cell}}^\eta \geq \widetilde{W}_{\text{cell}}^\eta$ .

For all  $\eta > 0$  and  $\Lambda \in \mathbb{M}^2$  invertible, we claim that

$$\widetilde{W}_{\text{cell}}^\eta(\Lambda) = \tilde{F}^\eta(\varphi_\Lambda, Q).$$

Let  $\psi$  be an admissible deformation of the form  $\psi = \varphi_\Lambda + \phi$ ,  $\phi \in \mathcal{S}_{\text{per}}(Q, \mathbb{R}^2)$ . Due to the periodicity constraint on  $Q$ , we have that

$$\frac{1}{4}(\det \nabla \psi|_{T_1} + \det \nabla \psi|_{T_2} + \det \nabla \psi|_{T_3} + \det \nabla \psi|_{T_4}) = \det \Lambda, \\ \frac{1}{4}(\det \nabla \psi|_{T_5} + \det \nabla \psi|_{T_6} + \det \nabla \psi|_{T_7} + \det \nabla \psi|_{T_8}) = \det \Lambda. \quad (3.2)$$

To prove this assertion, up to multiplying  $\nabla \psi$  by  $\Lambda^{-1}$ , it is enough to consider  $\Lambda = \mathbb{I}$ . Up to a translation, we can write

$$\begin{aligned} \psi(y^1) &= (\alpha_1, 1/2 + \beta_1) & \psi(y^5) &= (0, 1) \\ \psi(y^3) &= (1 + \alpha_1, 1/2 + \beta_1) & \psi(y^6) &= (0, 0) \\ \psi(y^2) &= (1/2 + \alpha_2, \beta_2) & \psi(y^7) &= (1, 0) \\ \psi(y^4) &= (1/2 + \alpha_2, 1 + \beta_2) & \psi(y^8) &= (1, 1) \end{aligned}$$

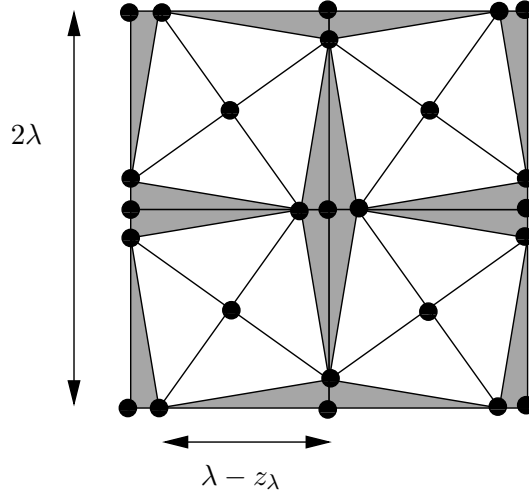

FIGURE 3. Deformation of  $Q_2$  by the  $Q_2$ -periodic competitor  $\psi$ .

for suitable  $\alpha_1, \alpha_2, \beta_1, \beta_2 \in \mathbb{R}$ . A straightforward calculation then shows that

$$\begin{aligned} \det \nabla \psi|_{T_1} &= 4(\alpha_1 \beta_2 - (\beta_1 - 1/2)(\alpha_2 + 1/2)) \\ \det \nabla \psi|_{T_2} &= 4(-\alpha_1 \beta_2 + (\beta_1 - 1/2)(\alpha_2 - 1/2)) \\ \det \nabla \psi|_{T_3} &= 4(-\alpha_1 \beta_2 + (\beta_1 + 1/2)(\alpha_2 + 1/2)) \\ \det \nabla \psi|_{T_4} &= 4(\alpha_1 \beta_2 - (\beta_1 + 1/2)(\alpha_2 - 1/2)). \end{aligned}$$

Thus, as expected,

$$\frac{1}{4}(\det \nabla \psi|_{T_1} + \det \nabla \psi|_{T_2} + \det \nabla \psi|_{T_3} + \det \nabla \psi|_{T_4}) = 1$$

and the second equation of (3.2) follows now from the fact that  $\int_Q \det(\Lambda + \nabla \phi) = \det \Lambda$  because  $\pm \det$  is quasiconvex.

Hence, by Jensen's inequality ( $f_2$  is a convex function),

$$\widetilde{W}_{\text{cell}}^\eta(\Lambda) = \frac{1}{2}(1 + \eta)f_2(\det \Lambda).$$

Since  $\widetilde{W}_{\text{cell}}^\eta$  is a polyconvex function (hence quasiconvex) not greater than  $W_{\text{cell}}^\eta$  on  $\mathbb{M}^2$ , for all  $\lambda \geq 1$  there holds

$$\mathcal{Q}W_{\text{cell}}^\eta(\lambda \mathbb{I}) \geq \widetilde{W}_{\text{cell}}^\eta(\lambda \mathbb{I}) \geq \frac{1}{2}f_2(\det \lambda \mathbb{I}) = \frac{1}{2}(\lambda^2 - 1)^2.$$

**Property 2).** Let  $z_\lambda$  be a solution of  $z_\lambda(\lambda - z_\lambda) = 1/8$ . We define a  $Q_2$ -periodic competitor  $\psi$  as on Figure 3. The deformation is the symmetrization in  $Q_2$  of the following deformation of the unit cube  $Q$ :

$$\begin{aligned} \psi(y^1) &= (0, z_\lambda) & \psi(y^5) &= (0, \lambda) \\ \psi(y^3) &= (\lambda - z_\lambda, \lambda) & \psi(y^6) &= (0, 0) \\ \psi(y^2) &= (\lambda, \lambda - z_\lambda) & \psi(y^7) &= (\lambda, 0) \\ \psi(y^4) &= (z_\lambda, \lambda) & \psi(y^8) &= (\lambda, \lambda). \end{aligned}$$

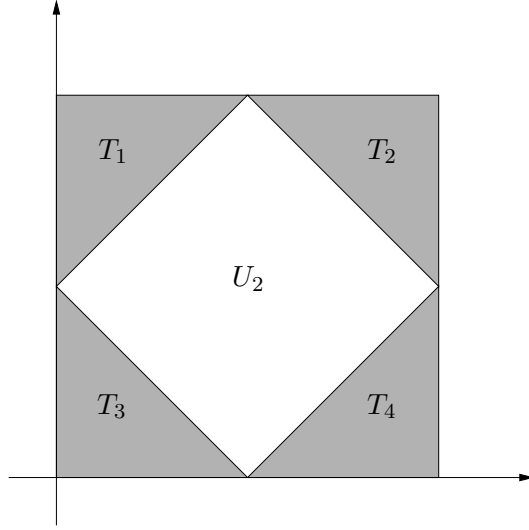

FIGURE 4. Geometry.

Since in triangles of the form  $T_i^m$ ,  $i \in \{1, 2, 3, 4\}$ , where the material is strong,

$$\det \nabla \psi = 1 \implies f_2(\det \nabla \psi) = 0,$$

one has  $F^\eta(\psi, Q_2) = \eta F^1(\psi, Q_2)$ . Hence, since  $\psi - \varphi_{\lambda \mathbb{I}} \in \mathcal{S}_{\text{per}}(Q_2, \mathbb{R}^2)$ , we have

$$W_{\text{hom}}^\eta(\lambda \mathbb{I}) \leq F^\eta(\psi, Q_2) \leq \eta F^1(\psi, Q_2).$$

□

**3.2. An example from solid-solid phase transformations.** To build the following counterexample, we introduce energy densities on  $Q$  such that a phenomenon similar to the one on Figure 2 may occur at the continuous level. The rigidity now relies on the set of matrices we introduce hereafter.

- Matrices in  $\mathbb{M}^2$

$$A_1 := \text{diag}(1, 1), \quad A_2 := \text{diag}(4, 3), \quad B_1 := \text{diag}(1, 3), \quad B_2 := \text{diag}(4, 1),$$

$$C := \frac{1}{2} \text{diag}(5, 4), \quad R := \frac{1}{\sqrt{2}} \begin{pmatrix} 1 & 1 \\ -1 & 1 \end{pmatrix}.$$

- Compact sets in  $\mathbb{M}^2$

$$K_1 := SO_2 A_1 \cup SO_2 A_2, \quad K_2 := SO_2 B_1 \cup SO_2 B_2,$$

$$H_1 := K_1 R, \quad H_2 := (K_2 R)^{pc}.$$

- Geometry (see Figure 4)

$$U_1 := \bigcup_{i=1}^4 T_i, \quad U_2 := Q \setminus U_1,$$

where  $T_1, \dots, T_4$  are defined as in (3.1).

The counterexample is as follows.



**Theorem 5.** *Let  $W_1, W_2 \in \mathcal{W}(a, p)$  be two quasiconvex functions (to be built later) such that*

$$W_1^{-1}(0) = H_1 \quad \text{and} \quad W_2^{-1}(0) = H_2. \quad (3.3)$$

*Consider the energy density  $W : \mathbb{R}^2 \times \mathbb{M}^2 \rightarrow [0, +\infty)$  defined by*

$$W(x, \Lambda) := \chi(x)W_1(\Lambda) + (1 - \chi(x))W_2(\Lambda),$$

*where  $\chi$  is given by  $\chi := \chi_{U_1}$  in  $Q$  and extended by periodicity to the whole  $\mathbb{R}^2$ . The following properties hold:*

- 1) *the cell integrand  $W_{\text{cell}}$  related to  $W$  is bounded from below by a constant  $c > 0$ ;*
- 2)  *$CR$  belongs to the zero levelset of the homogenized integrand  $W_{\text{hom}}$  related to  $W$ .*

*Therefore  $QW_{\text{cell}}(CR) \geq c > W_{\text{hom}}(CR)$ .*

We will make use of the following facts in the proof.

- i) *The compact set  $K_1$  is polyconvex and rigid, i.e., if  $U \subseteq \mathbb{R}^2$  is an open connected set and  $\psi : U \rightarrow \mathbb{R}^2$  is a Lipschitz function such that*

$$\nabla\psi(x) \in K_1 \quad \text{for a.e. } x \in U,$$

*then  $\psi$  is affine. We refer to [16, Theorem 2] and [14, Theorem 4.11] for the proofs. Since  $R$  is a rotation, the same properties hold for  $H_1$ .*

- ii)  *$H_1 \cap H_2 = \emptyset$ , because by Lemma 4*

$$H_2 \subseteq \{\Lambda \in \mathbb{M}^2 : \det \Lambda \in [3, 4]\}.$$

- iii)  *$A_1$  is rank-one connected to  $B_1$  and  $B_2$ , and  $A_2$  to  $B_1$  and  $B_2$  also. More precisely, denoted by  $\{\mathbf{e}_1, \mathbf{e}_2\}$  the canonical basis in  $\mathbb{R}^2$ ,*

$$\begin{aligned} A_1 - B_1 &= -2\mathbf{e}_2 \otimes \mathbf{e}_2 \\ A_1 - B_2 &= -3\mathbf{e}_1 \otimes \mathbf{e}_1 \\ A_2 - B_1 &= 3\mathbf{e}_1 \otimes \mathbf{e}_1 \\ A_2 - B_2 &= 2\mathbf{e}_2 \otimes \mathbf{e}_2. \end{aligned}$$

*Proof of Theorem 5.*

**Property 1).** Since  $W_{\text{cell}}$  grows superlineary at infinity and is continuous by Lemma 6, it is enough to prove that  $W_{\text{cell}}(\Lambda) \neq 0$  for any  $\Lambda \in \mathbb{M}^2$ . We proceed by contradiction and assume there exists  $\Lambda \in \mathbb{M}^2$  such that  $W_{\text{cell}}(\Lambda) = 0$ . By Lemma 8, there exists a  $Q$ -periodic Lipschitz function  $\phi : \mathbb{R}^2 \rightarrow \mathbb{R}^2$  such that

$$\Lambda + \nabla\phi(x) \in \begin{cases} H_1 & \text{for a.e. } x \in U_1 \\ H_2 & \text{for a.e. } x \in U_2 \end{cases}. \quad (3.4)$$

Due to the rigidity, we infer that there exists  $D_i \in H_1$  such that  $\Lambda + \nabla\phi(x) = D_i$  for a.e.  $x \in T_i$ . Again by the rigidity, the periodicity condition implies that there exists  $D \in H_1$  such that  $D_i = D$  for all  $i \in \{1, 2, 3, 4\}$ .

By observing that  $\psi(x) := (\Lambda - D) \cdot x + \phi(x)$  belongs to  $W_0^{1,\infty}(U_2)$  (up to a translation), from the definition of quasiconvexity we get

$$W_2(D) \leq \int_{U_2} W_2(D + \nabla\psi(x)) dx = \int_{U_2} W_2(\Lambda + \nabla\phi(x)) dx = 0$$

and so  $D \in H_2$ , which contradicts  $H_1 \cap H_2 = \emptyset$ .

**Property 2).** It is sufficient to find  $\phi \in W_{\text{per}}^{1,p}(Q_2, \mathbb{R}^2)$  such that

$$\int_{Q_2} W(x, CR + \nabla\phi(x)) dx = 0.$$

This can be accomplished by using the following function  $\psi : (-1/\sqrt{2}, 1/\sqrt{2})^2 \rightarrow \mathbb{R}^2$ ,

$$\psi^{(1)}(x) := \begin{cases} x_1 & \text{if } x \in (-1/\sqrt{2}, -\sqrt{2}/4) \times (-1/\sqrt{2}, 1/\sqrt{2}) \\ 4x_1 - 3\sqrt{2}/4 & \text{if } x \in [-\sqrt{2}/4, \sqrt{2}/4] \times (-1/\sqrt{2}, 1/\sqrt{2}) \\ x_1 + 3\sqrt{2}/2 & \text{if } x \in (\sqrt{2}/4, 1/\sqrt{2}) \times (-1/\sqrt{2}, 1/\sqrt{2}) \end{cases} ;$$

$$\psi^{(2)}(x) := \begin{cases} x_2 & \text{if } x \in (-1/\sqrt{2}, 1/\sqrt{2}) \times (-1/\sqrt{2}, -\sqrt{2}/4) \\ 3x_2 - \sqrt{2}/2 & \text{if } x \in (-1/\sqrt{2}, 1/\sqrt{2}) \times [-\sqrt{2}/4, \sqrt{2}/4] \\ x_2 + \sqrt{2} & \text{if } x \in (-1/\sqrt{2}, 1/\sqrt{2}) \times (\sqrt{2}/4, 1/\sqrt{2}) \end{cases} .$$

Let  $\varphi$  be the  $(-1/\sqrt{2}, 1/\sqrt{2})^2$ -periodic extension of  $\varphi : x \mapsto \psi(x) - C \cdot x$ . Then  $\phi : x \mapsto \varphi(R \cdot x)$  does the job. Actually, as illustrated on Figure 5,  $CR + \nabla\phi(x + m) \in H_1$  for  $(x, m) \in U_1 \times \mathbb{Z}^2$  and  $CR + \nabla\phi(x + m) \in H_2$  for  $(x, m) \in U_2 \times \mathbb{Z}^2$ .  $\square$

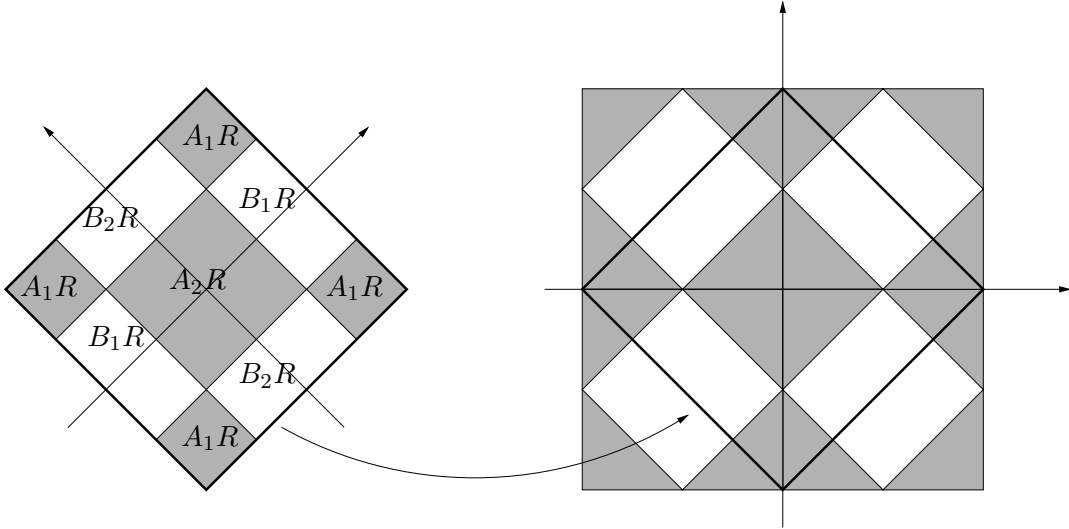

FIGURE 5. The values of  $CR + \nabla\phi$  in  $R^{-1}(-1/\sqrt{2}, 1/\sqrt{2})^2$ . On the left the axis are oriented in the directions  $R^{-1}\mathbf{e}_1$  and  $R^{-1}\mathbf{e}_2$ .

To complete the counterexample we need to build two quasiconvex functions  $W_1, W_2$  satisfying (3.3).

**Lemma 9.** *Let  $H$  be a compact, polyconvex and frame-invariant subset of  $\mathbb{M}^2$ . Given  $p \in (1, +\infty)$ , for a suitable  $a > 0$  there exists a quasiconvex frame-invariant function  $W \in \mathcal{W}(a, p)$  such that*

$$W^{-1}(0) = H.$$

*If  $p \geq 2$ , then  $W$  can be chosen polyconvex.*

*Proof.* Let  $V(\Lambda) := \text{dist}(\Lambda, H)^p$  and set  $W(\Lambda) := \mathcal{Q}V(\Lambda)$ . By Lemma 5,  $W^{-1}(0) = H$ . Since the Frobenius norm is frame-invariant, the same holds for  $V$ , and therefore for  $W$  since for all  $\Lambda \in \mathbb{M}^2$  and all  $R \in SO_2$ ,

$$\begin{aligned} W(R\Lambda) &= \inf \left\{ \int_Q V(R\Lambda + \nabla\phi) dx : \phi \in W_0^{1,p}(Q, \mathbb{R}^2) \right\} \\ &= \inf \left\{ \int_Q V(R\Lambda + R\nabla R^{-1}\phi) dx : \phi \in W_0^{1,p}(Q, \mathbb{R}^2) \right\} \\ &= \inf \left\{ \int_Q V(R(\Lambda + \nabla\varphi)) dx : \varphi \in W_0^{1,p}(Q, \mathbb{R}^2) \right\} \\ &= \inf \left\{ \int_Q V(\Lambda + \nabla\varphi) dx : \varphi \in W_0^{1,p}(Q, \mathbb{R}^2) \right\} = W(\Lambda). \end{aligned}$$

A different construction allows us to consider a polyconvex energy density in the case  $p \in [2, +\infty)$ . We define the functions

$$V_1(\Lambda) := \text{dist}(\Lambda, H^{co})^p \quad \text{and} \quad V_2(\Lambda) := \text{dist}(\mathbf{M}(\Lambda), L)^{\frac{p}{2}},$$

where  $L := \{\mathbf{M}(\Lambda) : \Lambda \in H\}^{co}$ . Both are polyconvex and with  $p$ -growth, moreover  $V_1$  is  $p$ -coercive and, by Lemma 4, the zero levelset of  $V_2$  is  $H$ . The function  $W := \max\{V_1, V_2\}$  does the job. In addition, it is easy to verify that also in this case  $W$  is frame-invariant.  $\square$

**Remark 4.** The previous lemma is optimal, because a polyconvex function with subquadratic growth is convex (see [9, Corollary 5.9]).

**3.3. Comparison of both examples.** In the discrete example, the zero levelset of the energy density of the strong phase is  $\mathcal{J} = \{\Lambda \in \mathbb{M}^2, \det \Lambda = 1\}$ , the space of isochoric deformations, which is not rigid. The rigidity comes from the structure of  $Q$ -periodic discrete gradients on  $\mathcal{T}_1$ .

In the continuous example, we replace  $\mathcal{S}_{\text{per}}^1(Q, \mathbb{R}^2)$  by  $W_{\text{per}}^{1,p}(Q, \mathbb{R}^2)$ , hence adding much more flexibility to the periodic gradients. In order to keep the required rigidity, we then replace  $\mathcal{J}$  by  $H_1$  in the strong phase.

The rigidity of the discrete example lies in (3.2), whereas the rigidity of the continuous example lies in (3.4).

Compared to Stefan Müller's example, the repartition of the strong phase in  $Q$  allows to take full advantage of the constraint of periodicity in both examples of this section. On the contrary, in Section 2.3, the periodicity constraint is lost in the  $x_1$ -direction, as shown by Proposition 1.

#### 4. COUNTEREXAMPLE ON PERFORATED DOMAINS

We obtain the counterexample using the same strategy as for the case of mixtures: we choose a suitable polyconvex function  $W : \mathbb{M}^d \rightarrow [0, +\infty)$  by focusing on its zero levelset  $K \subseteq \mathbb{M}^d$  first. Since  $Q \cap P$  is connected and we need a certain flexibility to construct a  $Q_2$ -periodic competitor, the set  $K$  shall not be too rigid.

Let us begin by describing the geometry of the subset  $P$ , sketched on Figure 6.

**Definition 11.** The set  $P$  is the complement in  $\mathbb{R}^2$  of the set  $\bigcup_{m \in \mathbb{Z}^2} O + m$ , where

$$O := \{x \in Q : x_1 \in [1/8, 7/8] \text{ and } 3x_1 \leq 4x_2 \leq 3x_1 + 1\}.$$

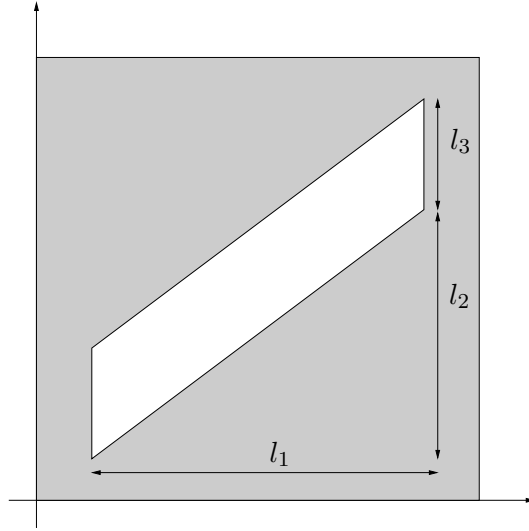
FIGURE 6. In grey the set  $Q \cap P$ .

Let us introduce some sets in the space  $\mathbb{M}^2$ , that we will use to describe the energy density.

**Definition 12.** Let  $l_1 := 3/4$ ,  $l_2 := 9/16$  and  $l_3 := 1/4$ . We consider the following sets (see Figure 7):

- $K_1 := \{\text{diag}(s, 0) : s \in (0, 1]\}$  and  $K_2 := \{\text{diag}(0, t) : t \in (0, 1]\}$ ;
- $K := K_1 \cup K_2 \cup \{\text{diag}(0, 0)\}$ ;
- $H := \{\text{diag}(s, t) : s, t \in [0, 1] \text{ and } t \leq 1 - s\}$ ;
- $L := \{\text{diag}(s, t) : 0 < s \leq l_1 l_3 / l_2 \text{ and } 0 < t \leq l_3 - l_2 s / l_1\}$ ;
- $M := \{\text{diag}(s, t) : 0 < s \leq l_1 / 2 \text{ and } 0 < t \leq l_3\}$ .

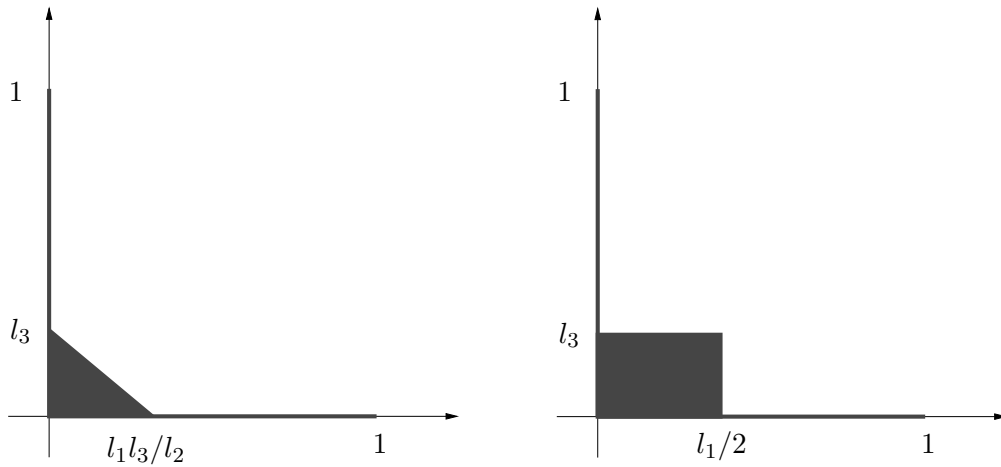
FIGURE 7. A representation of  $K \cup L$  and  $K \cup M$  in  $\mathbb{R}^2$ , identified with the set of the diagonal matrices.

The counterexample is as follows.

**Theorem 6.** *Let  $p \in [2, +\infty)$  and let  $W : \mathbb{M}^2 \rightarrow [0, +\infty)$  be given by*

$$W(\Lambda) := \text{dist}(\Lambda, H)^p + |\det(\Lambda)|^{\frac{p}{2}},$$

where  $H$  is as in Definition 12. Then,  $W$  is polyconvex and belongs to  $\mathcal{W}(a, p)$  for a suitable  $a > 0$ . Moreover, with the notation of Definitions 11 and 12, there holds

- 1) the zero levelset of the cell integrand  $W_{\text{cell}}$  related to  $(W, P)$  coincides with  $K \cup L$ ;
- 2) the zero levelset of the homogenized integrand  $W_{\text{hom}}$  related to  $(W, P)$  contains  $K \cup M$ ;
- 3)  $K \cup L$  is quasiconvex.

Therefore, for all  $\Lambda \in (K \cup M) \setminus (K \cup L) \neq \emptyset$ ,  $\mathcal{Q}W_{\text{cell}}(\Lambda) > W_{\text{hom}}(\Lambda) = 0$ .

*Proof.* The set  $H$  being convex,  $\Lambda \mapsto \text{dist}(\Lambda, H)^p$  is a convex function. Since  $\Lambda \mapsto |\det \Lambda|^{\frac{p}{2}}$  is polyconvex,  $W$  is polyconvex. It is easy to verify that  $W$  satisfies (2.1) for a suitable  $a > 0$ . The strict inequality  $\mathcal{Q}W_{\text{cell}}(\Lambda) > W_{\text{hom}}(\Lambda)$  is a direct consequence of 1)-3) using Lemma 5. Let us split the proof of 1)-3) into three steps.

**Step 1.** Since  $W^{-1}(0) = K$ , by using  $\phi \equiv 0$  as a test function in (2.2), we obtain  $K \subseteq W_{\text{cell}}^{-1}(0)$ . Let us check that  $L \subseteq W_{\text{cell}}^{-1}(0)$ . Given  $s \in (0, l_1 l_3 / l_2)$  and  $t \in (0, l_3 - l_2 s / l_1)$ , we define  $\psi : Q \rightarrow \mathbb{R}^2$  by

$$\psi^{(1)}(x) := \begin{cases} 0 & \text{if } x \in (0, 1/2) \times (0, 1) \\ x_1 - 1/2 & \text{if } x \in [1/2, 1/2 + s] \times (0, 1) ; \\ s & \text{if } x \in (1/2 + s, 1) \times (0, 1) \end{cases} \quad (4.1)$$

$$\psi^{(2)}(x) := \begin{cases} 0 & \text{if } x \in (0, 1) \times (0, 5/8 - t) \\ x_2 - 5/8 + t & \text{if } x \in (0, 1) \times [5/8 - t, 5/8] . \\ t & \text{if } x \in (0, 1) \times (5/8, 1) \end{cases}$$

We have that  $\phi(x) := \psi(x) - \text{diag}(s, t) \cdot x$  is  $Q$ -periodic and that  $\nabla \psi(x) \in K$  if  $x \in P$ . More precisely,  $\nabla \psi(x) \notin K$  only if  $x$  belongs to  $[1/2, 1/2 + s] \times [5/8 - t, 5/8] \subseteq O$ . There,  $\nabla \psi \equiv \text{diag}(1, 1)$  (see Figures 8 and 9).

It remains to proceed with the delicate part of the argument: the opposite inclusion  $W_{\text{cell}}^{-1}(0) \subseteq K \cup L$ . Let  $C = (c_{ij}) \in W_{\text{cell}}^{-1}(0)$ . By Lemma 7, there exists a Lipschitz function  $\psi : Q \rightarrow \mathbb{R}^2$  such that  $\nabla \psi(x) \in K$  for  $\mathcal{L}^2$  a.e.  $x \in Q \cap P$  and  $\phi(x) := \psi(x) - C \cdot x$  is  $Q$ -periodic. We will show that  $\psi$  is substantially a laminate as in (4.1). Let us point out that if  $\Lambda \in K$ , then either  $\Lambda_{11} = 0$  or  $\Lambda_{22} = 0$ .

We use the following notation:

$$L^s := \{r \in (0, 1) : (s, r) \in (\{s\} \times (0, 1)) \cap P\};$$

$$L_s := \{r \in (0, 1) : (r, s) \in ((0, 1) \times \{s\}) \cap P\}.$$

Notice that  $L^s = (0, 1)$  if  $s \in (0, 1/8) \cup (7/8, 1)$  and that  $L^s$  has two connected components if  $s \in [1/8, 7/8]$ . Similarly,  $L_s = (0, 1)$  if  $s \in (0, 3/32) \cup (29/32, 1)$  and it has two connected components if  $s \in [3/32, 29/32]$ .

Since  $\partial_2 \psi^{(1)}(x) = 0$  for  $\mathcal{L}^2$  a.e.  $x \in Q \cap P$ ,  $\psi^{(1)}(s, \cdot)$  is constant along any connected component of  $L^s$  for all  $s \in (0, 1)$ . In particular for  $s \in (0, 1/8) \cup (7/8, 1)$ ,  $\psi^{(1)}(s, \cdot)$  is constant and therefore the  $(0, 1)$ -periodicity of  $\phi(s, \cdot)$  imposes that  $c_{12} = 0$ . For  $s \in$

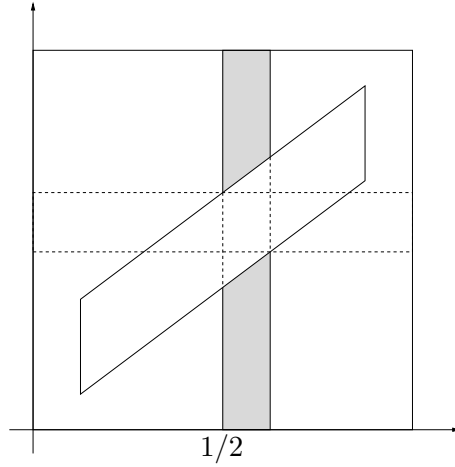

FIGURE 8. The first component of  $\psi$  is flat on  $Q \cap P$  with the exception of the grey zone, where the gradient is equal to  $(1, 0)$ .

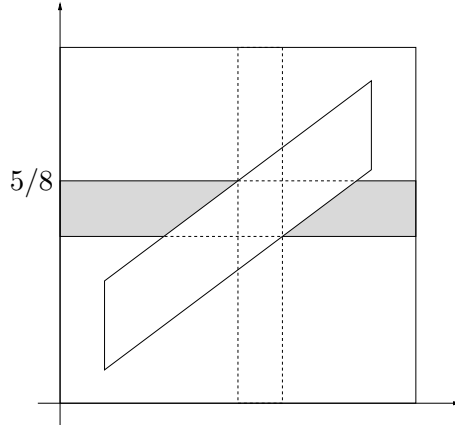

FIGURE 9. The second component of  $\psi$  is flat on  $Q \cap P$  with the exception of the grey zone, where the gradient is equal to  $(0, 1)$ .

$[1/8, 7/8]$ ,  $\psi^{(1)}(s, \cdot)$  is constant on each of the two connected components of  $L^s$ . Hence, by periodicity,  $\psi^{(1)}(s, \cdot)$  is constant on the whole  $L^s$ .

From the fact that  $\psi^{(1)}(s, \cdot)$  is constant along  $L^s$  for any  $s \in (0, 1)$ , we can deduce that if  $\bar{x} \in Q \cap P$  is a differentiability point for  $\psi^{(1)}$ , then  $\psi^{(1)}$  is differentiable in all  $\{\bar{x}_1\} \times L^{\bar{x}_1}$  and

$$\nabla \psi^{(1)}(x) = \nabla \psi^{(1)}(\bar{x}) \quad \forall x \in \{\bar{x}_1\} \times L^{\bar{x}_1}. \quad (4.2)$$

Similarly, one can show that  $c_{21} = 0$  and that if  $\bar{x} \in Q \cap P$  is a differentiability point for  $\psi^{(2)}$ , then  $\psi^{(2)}$  is differentiable in all  $L^{\bar{x}_2} \times \{\bar{x}_2\}$  and

$$\nabla \psi^{(2)}(x) = \nabla \psi^{(2)}(\bar{x}) \quad \forall x \in L^{\bar{x}_2} \times \{\bar{x}_2\}. \quad (4.3)$$

Let  $X_1, X_2$  be two  $\mathcal{L}^1$ -negligible subsets of the interval  $(0, 1)$  such that  $\psi$  is differentiable in  $\tilde{P} := (Q \cap P) \setminus (X_1 \times X_2)$  and  $\nabla \psi(x) \in K$  for all  $x \in \tilde{P}$ . Let us show that, if for some

$\bar{x} \in \tilde{P}$  there holds  $\nabla\psi(\bar{x}) \in K_1$ , then

$$\nabla\psi(x) \in K_1 \cup \{\text{diag}(0,0)\} \quad \forall x \in \tilde{P} \cap ((0,1) \times L^{\bar{x}_1}). \quad (4.4)$$

In fact, since  $\nabla\psi^{(1)}(\bar{x}) \neq (0,0)$ , we have  $\nabla\psi^{(1)} \neq (0,0)$  in  $\{\bar{x}_1\} \times L^{\bar{x}_1}$  due to (4.2) and therefore  $\nabla\psi \in K_1$  in  $\{\bar{x}_1\} \times (L^{\bar{x}_1} \setminus X_2)$ . As now  $\nabla\psi^{(2)} \equiv (0,0)$  in  $\{\bar{x}_1\} \times (L^{\bar{x}_1} \setminus X_2)$ , (4.3) implies that  $\nabla\psi^{(2)} \equiv (0,0)$  in  $\tilde{P} \cap ((0,1) \times L^{\bar{x}_1})$ .

We are in position to conclude the first step. Given  $\bar{s} \in (0, 1/8) \setminus X_1$  and  $\bar{t} \in (0, 3/32) \setminus X_2$ , we define the following two sets.

$$\begin{aligned} S &:= \{s \in (0,1) \setminus X_1 : \partial_1\psi^{(1)}(s, \bar{t}) > 0\}; \\ T &:= \{t \in (0,1) \setminus X_2 : \partial_2\psi^{(2)}(\bar{s}, t) > 0\}. \end{aligned}$$

Since  $\nabla\psi \in K$ ,  $\partial_1\psi^{(1)}(s, \bar{t}) \leq 1$  for all  $s \in S$ , and we infer from

$$c_{11} = \int_0^1 c_{11} + \partial_1\psi^{(1)}(s, \bar{t}) ds = \int_0^1 \partial_1\psi^{(1)}(s, \bar{t}) ds = \int_S \partial_1\psi^{(1)}(s, \bar{t}) ds,$$

that  $0 \leq c_{11} \leq \mathcal{L}^1(S)$ . Similarly,  $0 \leq c_{22} \leq \mathcal{L}^1(T)$ . In particular this shows that

$$c_{11}, c_{22} \in [0, 1].$$

If  $c_{11} > 0$ , for any  $\varepsilon > 0$  there exist  $s_1, s_2 \in S$  such that  $s_2 - s_1 \geq c_{11} - \varepsilon$ . Recalling that if  $\nabla\psi(x) \in K$  and  $\partial_1\psi^{(1)}(x) > 0$  then  $\nabla\psi(x) \in K_1$ , from (4.4), we obtain

$$\nabla\psi(x) \in K_1 \cup \{\text{diag}(0,0)\} \quad \forall x \in \tilde{P} \cap ((0,1) \times (L^{s_1} \cup L^{s_2})).$$

Since  $T \subseteq (0,1) \setminus (L^{s_1} \cup L^{s_2})$ , we have the estimate

$$c_{22} \leq \mathcal{L}^1(T) \leq \max\left\{0, \frac{l_2}{l_1}(s_1 - s_2) + l_3\right\} \leq \max\left\{0, \frac{l_2}{l_1}(-c_{11} + \varepsilon) + l_3\right\}.$$

The arbitrariness of  $\varepsilon > 0$  completes the proof of the step.

**Step 2.** Since  $W_{\text{hom}}$  is rank-one convex and  $W_{\text{hom}}^{-1}(0) \supseteq K$ , it is sufficient to prove that

$$C := \text{diag}(l_1/2, l_3) \in W_{\text{hom}}^{-1}(0).$$

Let us construct a Lipschitz function  $\psi : Q_2 \rightarrow \mathbb{R}^2$  such that  $\nabla\psi \in K$  a.e. in  $Q_2 \cap P$  and  $\phi(x) := \psi(x) - C \cdot x$  is  $Q_2$ -periodic. In this way we get

$$W_{\text{hom}}(C) \leq \frac{1}{4} \int_{Q_2 \cap P} W(C + \nabla\phi(x)) dx = 0.$$

Despite the complexity of the following description, the function  $\psi$  is very simple.

Consider the following sets (see Figure 10):

- $U := \{x \in [1/8, 1] \times [3/32, 3/32 + l_2] : 4x_2 < 3x_1\}$ ;
- $U_1 := ([0, 1] \times [0, 3/32 + l_2]) \setminus (U \cup O)$ ;
- $U_2 := \{x \in [1/8, 1] \times [3/32, 3/32 + l_3] : 4x_2 < 3x_1\}$ ;
- $U_3 := \{x \in [0, 1]^2 : (1, 1) - x \in U_2\}$ ;
- $U_4 := \{x \in [0, 1]^2 : (1, 1) - x \in U_1\}$ ;
- $U_5 := U \cup ([0, 1] \times [0, 1/8])$ ;
- $U_6 := [0, 1/8] \times [3/32, 3/32 + l_3]$ ;

- $U_7 := \{x \in [0, 1]^2 : (1, 1) - x \in U_6\}$ ;
- $U_8 := \{x \in [0, 1]^2 : (1, 1) - x \in U_5\}$ .

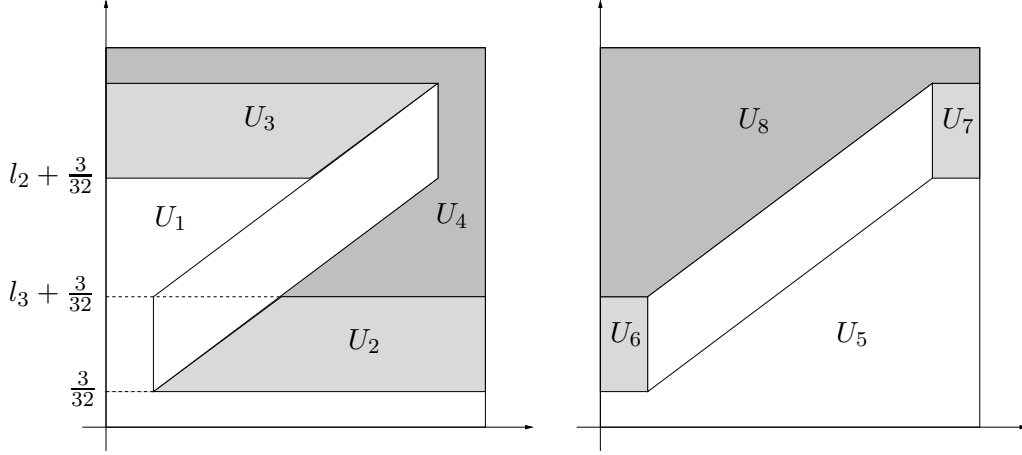

FIGURE 10

To simplify the exposition, we introduce two auxiliary Lipschitz functions  $\varphi_1, \varphi_2 : [0, 1]^2 \setminus O \rightarrow \mathbb{R}$ :

$$\varphi_1(x) := \begin{cases} 0 & \text{if } x \in U_1 \\ x_2 - 3/32 & \text{if } x \in U_2 \\ x_2 - l_2 - 3/32 & \text{if } x \in U_3 \\ h_3 & \text{if } x \in U_4 \end{cases}; \quad \varphi_2(x) := \begin{cases} 0 & \text{if } x \in U_5 \\ x_2 - 3/32 & \text{if } x \in U_6 \\ x_2 - l_2 - 3/32 & \text{if } x \in U_7 \\ h_3 & \text{if } x \in U_8 \end{cases}.$$

Both  $\varphi_1$  and  $\varphi_2$  can be extended to Lipschitz maps in all  $[0, 1]^2$ .

We are now in position to define the desired function  $\psi : Q_2 \rightarrow \mathbb{R}^2$  (see Figures 11, 12 and 13).

$$\psi^{(1)}(x) := \begin{cases} 0 & \text{if } x \in (0, 9/8] \times (0, 2) \\ x_1 - 9/8 & \text{if } x \in (9/8, 9/8 + l_1] \times (0, 2) \\ l_1 & \text{if } x \in (9/8 + l_1, 2) \times (0, 2) \end{cases} \quad (4.5)$$

$$\psi^{(2)}(x) := \begin{cases} \varphi_1(x) & \text{if } x \in (0, 1] \times (0, 1] \\ \varphi_2(x - (1, 0)) & \text{if } x \in (1, 2) \times (0, 1] \\ \varphi_1(x - (0, 1)) + l_3 & \text{if } x \in (0, 1] \times (1, 2) \\ \varphi_2(x - (1, 1)) + l_3 & \text{if } x \in (1, 2) \times (1, 2) \end{cases}.$$

**Step 3.** The set  $H$  is convex and so the inclusion  $(K \cup L)^{qc} \subseteq H$  is immediate.

As a direct consequence of [15, Theorem 1], for any  $C \in \mathbb{M}_{\text{sym}}^2$  the set

$$N_C := \{D \in \mathbb{M}_{\text{sym}}^2 : D - C \text{ is not positive definite}\}$$

is quasiconvex. Since for any  $D \in H \setminus (K \cup L)$  there exists a  $C \in H \setminus (K \cup L)$  such that

$$D \notin N_C, \quad \text{whereas} \quad K \cup L \subseteq N_C,$$



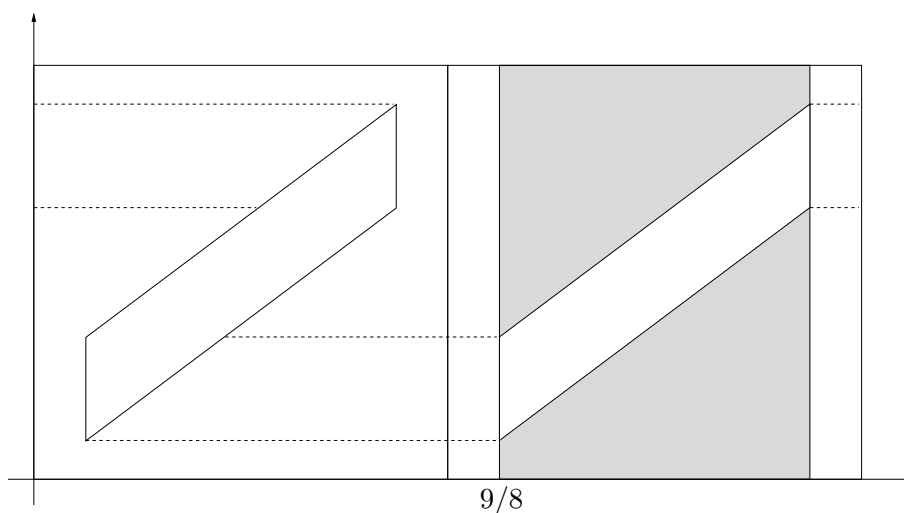

FIGURE 11. In  $[(0, 2) \times (0, 1)] \cap P$  the first component of  $\psi$  is flat with the exception of the grey zone, where the gradient is equal to  $(1, 0)$ .

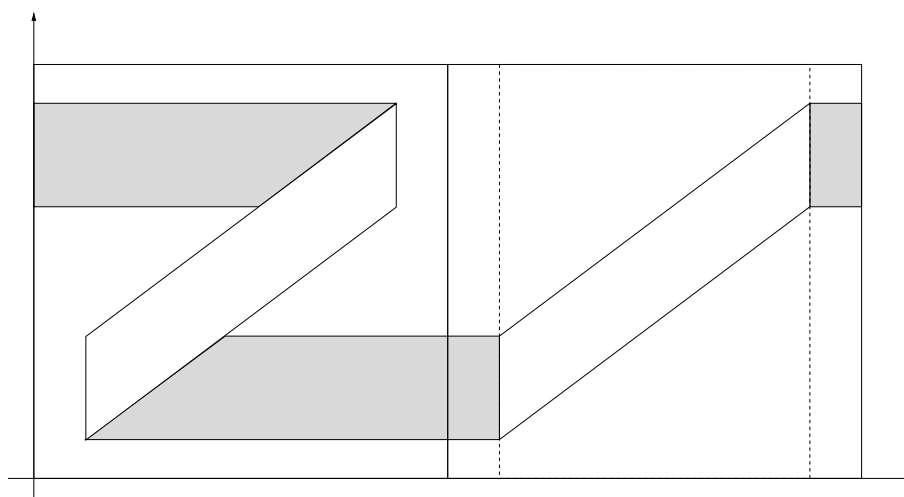

FIGURE 12. In  $[(0, 2) \times (0, 1)] \cap P$  the second component of  $\psi$  is flat with the exception of the grey zone, where the gradient is equal to  $(0, 1)$ .

we can conclude that

$$(K \cup L)^{qc} \subseteq H \cap \left( \bigcap_{C \in \mathcal{H} \setminus (K \cup L)} N_C \right) = K \cup L$$

and then  $K \cup L$  is quasiconvex. □

**Remark 5.** The proof of Theorem 6 does not take advantage of the particular structure of  $W$  but it is based only on the fact that  $W^{-1}(0) = K$ . Therefore, instead of  $W$  we can consider the function  $V : \mathbb{M}^2 \rightarrow [0, +\infty)$  defined as the quasiconvex envelope of  $\text{dist}(\cdot, K)^p$ ,  $p \in (1, +\infty)$ . Indeed, since  $K$  is polyconvex (because zero levelset of the

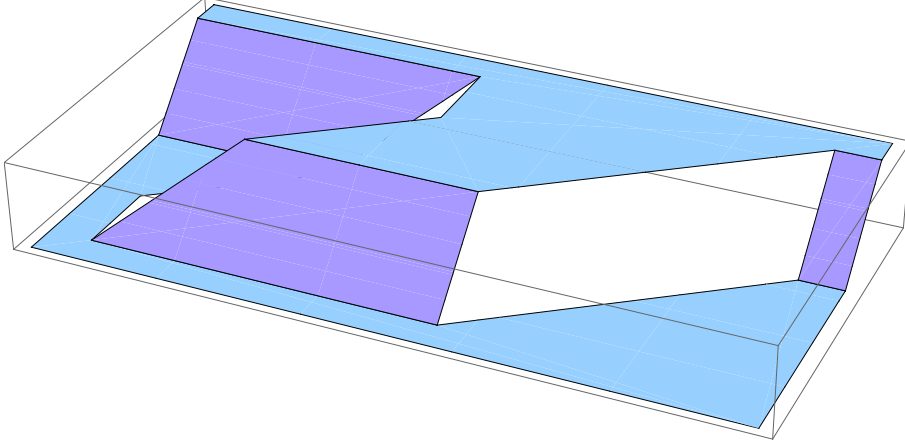

FIGURE 13. The graph of the second component of  $\psi$  in  $[(0, 2) \times (0, 1)] \cap P$ .

polyconvex function  $W$ ), by Lemma 5 it follows that  $V^{-1}(0) = K$ . Note that in this way our counterexample covers also the case of energy densities with growth  $p \in (1, 2)$ .

**Remark 6.** Let  $N$  be a convex and compact subset of  $\mathbb{M}^2$  sufficiently large so that  $\nabla\psi \in N$  *a.e.* in  $Q_2$ , where  $\psi$  is defined as in (4.5). Consider now the function  $V : \mathbb{R}^2 \times \mathbb{M}^2 \rightarrow [0, +\infty)$  defined by

$$V(x, \Lambda) := \chi_P(x)W(\Lambda) + (1 - \chi_P(x))\text{dist}(\Lambda, N)^p.$$

Since  $W_{\text{cell}} \leq V_{\text{cell}}$ , we have the inclusion  $V_{\text{cell}}^{-1}(0) \subseteq K \cup L$ . We also have the inclusion  $K \cup M \subseteq V_{\text{hom}}^{-1}(0)$ : in fact  $K \subseteq V_{\text{hom}}^{-1}(0)$  (because  $K \subseteq N$ ) and  $\text{diag}(h_1/2, h_3) \in V_{\text{hom}}^{-1}(0)$  (by using again  $\psi$ ). In this way we can conclude that also by mixing a polyconvex function and a convex function, the inequality  $\mathcal{Q}V_{\text{cell}} > V_{\text{hom}}$  can occur.

#### APPENDIX: STEFAN MÜLLER'S EXAMPLE IN DIMENSION THREE

To show that Proposition 1 is not peculiar to dimension two, let us consider the corresponding energy for a three-dimensional soft material reinforced by a strong plate. The energy is now given by  $W_0 : \mathbb{M}^3 \ni \Lambda \mapsto |\Lambda|^4 + f(\det \Lambda)$  where

$$f(z) := \begin{cases} \frac{12(1+a)^2}{z+a} - 12(1+a) - 9 & \text{if } z > 0 \\ \frac{12(1+a)^2}{a} - 12(1+a) - 9 - \frac{12(1+a)^2}{a^2}z & \text{if } z \leq 0 \end{cases}$$

for  $a \in (0, 1/2)$ . The energy density under consideration is still of the form  $W^\eta : \mathbb{R}^3 \times \mathbb{M}^3 \rightarrow [0, +\infty)$ ,  $(y, \Lambda) \mapsto \chi^\eta(y)W_0(\Lambda)$  where  $\chi^\eta$  is the  $Q$ -periodic extension on  $\mathbb{R}^3$  of

$$\chi^\eta(y) := \begin{cases} 1 & \text{if } y_1 \in (0, 1/2) \\ \eta & \text{if } y_1 \in [1/2, 1) \end{cases},$$

with  $Q = (0, 1)^3 \ni y = (y_1, y_2, y_3)$  and  $\eta > 0$ . Such an energy density is nonnegative, polyconvex, frame-invariant and its zero-levelset is  $SO_3$ .

**Proposition 2.** For all  $\lambda_1, \lambda_2 \in (0, 1)$ , there exists  $c > 0$  independent of  $\eta$  such that

$$\mathcal{Q}W_{\text{cell}}^\eta(\Lambda) \leq \eta c,$$

where  $\Lambda := \text{diag}(1, \lambda_1, \lambda_2)$ .

*Proof.* Essentially, one has to construct a Lipschitz domain  $U$  of  $\mathbb{R}^3$ , a function  $\phi \in W_{\text{per}}^{1,\infty}(U, \mathbb{R}^3)$  and a function  $\varphi \in L^\infty(U, W_{\text{per}}^{1,\infty}(Q, \mathbb{R}^3))$  such that  $\Lambda + \nabla\phi(x) + \nabla_y\varphi(x, y) \in SO_3$  for all  $x \in U$  and  $y \in (0, 1/2) \times (0, 1)^2$  (the strong phase of the material).

**Notation.** The canonical basis of  $\mathbb{R}^3$  is denoted by  $\{\mathbf{e}_1, \mathbf{e}_2, \mathbf{e}_3\}$ .

We will use the angles  $\theta$  and  $\gamma$  defined by

$$\begin{aligned} \cos \theta &= \lambda_1, & \sin \theta &= \sqrt{1 - \lambda_1^2}, \\ \cos \gamma &= \lambda_2, & \sin \gamma &= \sqrt{1 - \lambda_2^2}. \end{aligned}$$

We set  $\rho := \sqrt{\sin^2 \theta + \cos^2 \theta \sin^2 \gamma}$  and define the unit vectors  $\mathbf{e}_4$  and  $\mathbf{e}_5$  by

$$\begin{aligned} \mathbf{e}_4 &:= \frac{1}{\rho} (\sin \theta \mathbf{e}_2 + \cos \theta \sin \gamma \mathbf{e}_3), \\ \mathbf{e}_5 &:= \frac{1}{\rho} (\sin \theta \mathbf{e}_2 - \cos \theta \sin \gamma \mathbf{e}_3). \end{aligned}$$

**Definition of  $U$ .** In order to describe  $U$ , we need the following quantity

$$\tau := \frac{\cos \theta \sin \gamma}{\sin \theta}.$$

We set  $U := U_1 \cup U_2 \cup U_3 \cup U_4$ , where

$$\begin{aligned} U_1 &:= \{(x_1, x_2, x_3) : 0 < x_1 < 1; 0 < x_3 \leq 1/2; 1/2 - \tau x_3 \leq x_2 < 1 - \tau x_3\}, \\ U_2 &:= \{(x_1, x_2, x_3) : 0 < x_1 < 1; 0 < x_3 \leq 1/2; -\tau x_3 < x_2 \leq 1/2 - \tau x_3\}, \\ U_3 &:= \{(x_1, x_2, x_3) : 0 < x_1 < 1; 1/2 \leq x_3 < 1; 1/2 - \tau(1 - x_3) \leq x_2 < 1 - \tau(1 - x_3)\}, \\ U_4 &:= \{(x_1, x_2, x_3) : 0 < x_1 < 1; 1/2 \leq x_3 < 1; -\tau(1 - x_3) < x_2 \leq 1/2 - \tau(1 - x_3)\}. \end{aligned}$$

The domains  $U_1, U_2, U_3, U_4$  are sketched on Figure 14. Note that the interface between  $U_1$  and  $U_2$  (resp.  $U_3$  and  $U_4$ ) is perpendicular to  $\mathbf{e}_4$  (resp.  $\mathbf{e}_5$ ).

**Definition of  $\phi$ .** We consider the piecewise constant function  $G \in L^\infty(U, \mathbb{M}^3)$  of the form

$$G = \begin{pmatrix} 0 & \times & \times \\ 0 & \times & \times \\ 0 & 0 & 0 \end{pmatrix},$$

where the non zero two-dimensional submatrix  $\begin{pmatrix} \times & \times \\ \times & \times \end{pmatrix}$  is one the following four possible submatrices:

$$\begin{aligned} A_1 &:= \begin{pmatrix} \sin \theta & \cos \theta \sin \gamma \\ 0 & -\sin \theta \sin \gamma \end{pmatrix} \text{ in } U_1, & A_2 &:= \begin{pmatrix} -\sin \theta & -\cos \theta \sin \gamma \\ 0 & -\sin \theta \sin \gamma \end{pmatrix} \text{ in } U_2, \\ A_3 &:= \begin{pmatrix} \sin \theta & -\cos \theta \sin \gamma \\ 0 & \sin \theta \sin \gamma \end{pmatrix} \text{ in } U_3, & A_4 &:= \begin{pmatrix} -\sin \theta & \cos \theta \sin \gamma \\ 0 & \sin \theta \sin \gamma \end{pmatrix} \text{ in } U_4, \end{aligned}$$

according to Figure 14.

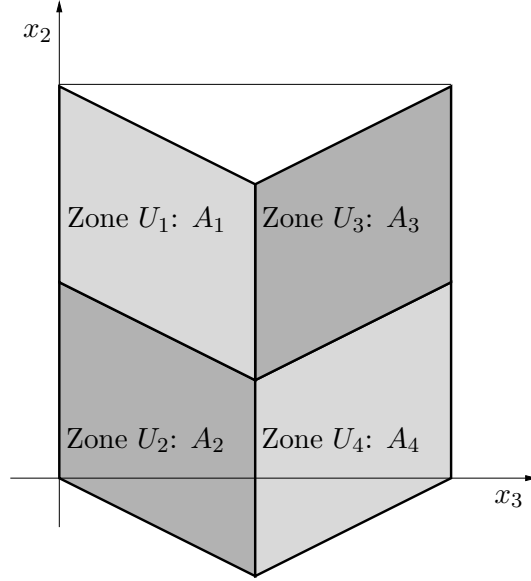
FIGURE 14. Domain  $U$  (in the plane generated by  $\{\mathbf{e}_2, \mathbf{e}_3\}$ ).

Let us check that  $G$  is a gradient field:

$$\begin{aligned}
 A_1 - A_3 &= 2[\cos \theta \sin \gamma \mathbf{e}_1 - \sin \theta \sin \gamma \mathbf{e}_2] \otimes \mathbf{e}_3 \\
 A_2 - A_4 &= 2[-\cos \theta \sin \gamma \mathbf{e}_1 - \sin \theta \sin \gamma \mathbf{e}_2] \otimes \mathbf{e}_3 \\
 A_1 - A_2 &= 2\mathbf{e}_1 \otimes [\sin \theta \mathbf{e}_2 + \cos \theta \sin \gamma \mathbf{e}_3] \\
 &= 2\rho \mathbf{e}_1 \otimes \mathbf{e}_4 \\
 A_3 - A_4 &= 2\mathbf{e}_1 \otimes [\sin \theta \mathbf{e}_2 - \cos \theta \sin \gamma \mathbf{e}_3] \\
 &= 2\rho \mathbf{e}_1 \otimes \mathbf{e}_5.
 \end{aligned}$$

These couples of matrices being rank-one connected,  $G$  is actually a gradient field  $\nabla \phi$  on  $U$ . This gradient can be extended by periodicity (due to the boundary conditions).

**Definition of  $\varphi$ .** We consider the following specific rotations in 3D, which are compositions of rotations around  $\mathbf{e}_2$  and  $\mathbf{e}_3$ :

$$\begin{aligned}
 R(\alpha, \beta) &:= \begin{pmatrix} \cos \alpha & -\sin \alpha & 0 \\ \sin \alpha & \cos \alpha & 0 \\ 0 & 0 & 1 \end{pmatrix} \begin{pmatrix} \cos \beta & 0 & \sin \beta \\ 0 & 1 & 0 \\ -\sin \beta & 0 & \cos \beta \end{pmatrix} \\
 &= \begin{pmatrix} \cos \beta \cos \alpha & -\sin \alpha & \cos \alpha \sin \beta \\ \cos \beta \sin \alpha & \cos \alpha & \sin \alpha \sin \beta \\ -\sin \beta & 0 & \cos \beta \end{pmatrix},
 \end{aligned}$$

where  $\alpha$  and  $\beta$  are the two angles. We also denote by  $\bar{\chi}$  the  $Q$ -periodic extension on  $\mathbb{R}^3$  of

$$\bar{\chi}(y) := \begin{cases} 1 & \text{if } y_1 \in (0, 1/2) \\ -1 & \text{if } y_1 \in [1/2, 1) \end{cases}.$$

We construct a function  $\varphi$  of the form  $\varphi(x, y) := \sum_{i=1}^4 \chi_{U_i}(x) \varphi_i(y)$ , where  $\varphi_1, \dots, \varphi_4$  are defined as follows.

*Zone 1.* For  $x \in U_1$ ,

$$\Lambda + \nabla\phi(x) = \begin{pmatrix} 1 & \sin\theta & \cos\theta \sin\gamma \\ 0 & \cos\theta & -\sin\theta \sin\gamma \\ 0 & 0 & \cos\gamma \end{pmatrix}.$$

We then choose  $\varphi_1 \in W_{\text{per}}^{1,\infty}(Q, \mathbb{R}^3)$  such that

$$\nabla\varphi_1(y) = \bar{\chi}(y) \begin{pmatrix} \cos\gamma \cos\theta - 1 & 0 & 0 \\ -\cos\gamma \sin\theta & 0 & 0 \\ -\sin\gamma & 0 & 0 \end{pmatrix}.$$

In the strong phase ( $\bar{\chi}(y) = 1$ ),

$$\Lambda + \nabla\phi(x) + \nabla\varphi_1(y) = \begin{pmatrix} \cos\gamma \cos\theta & \sin\theta & \cos\theta \sin\gamma \\ -\cos\gamma \sin\theta & \cos\theta & -\sin\theta \sin\gamma \\ -\sin\gamma & 0 & \cos\gamma \end{pmatrix} = R(\tilde{\theta}, \gamma)$$

is a rotation, with  $\tilde{\theta} = -\theta$ . In the soft phase ( $\bar{\chi}(y) = -1$ )

$$\Lambda + \nabla\phi(x) + \nabla\varphi_1(y) = \begin{pmatrix} 2 - \cos\gamma \cos\tilde{\theta} & -\sin\tilde{\theta} & \cos\tilde{\theta} \sin\gamma \\ -\cos\gamma \sin\tilde{\theta} & \cos\tilde{\theta} & \sin\tilde{\theta} \sin\gamma \\ \sin\gamma & 0 & \cos\gamma \end{pmatrix}.$$

*Zone 2.* For  $x \in U_2$ ,

$$\Lambda + \nabla\phi(x) = \begin{pmatrix} 1 & -\sin\theta & -\cos\theta \sin\gamma \\ 0 & \cos\theta & -\sin\theta \sin\gamma \\ 0 & 0 & \cos\gamma \end{pmatrix}.$$

We then choose  $\varphi_2 \in W_{\text{per}}^{1,\infty}(Q, \mathbb{R}^3)$  such that

$$\nabla\varphi_2(y) = \bar{\chi}(y) \begin{pmatrix} \cos\gamma \cos\theta - 1 & 0 & 0 \\ \cos\gamma \sin\theta & 0 & 0 \\ \sin\gamma & 0 & 0 \end{pmatrix}.$$

In the strong phase ( $\bar{\chi}(y) = 1$ ),

$$\Lambda + \nabla\phi(x) + \nabla\varphi_2(y) = \begin{pmatrix} \cos\gamma \cos\theta & -\sin\theta & -\cos\theta \sin\gamma \\ \cos\gamma \sin\theta & \cos\theta & -\sin\theta \sin\gamma \\ \sin\gamma & 0 & \cos\gamma \end{pmatrix} = R(\theta, \tilde{\gamma})$$

is a rotation, with  $\tilde{\gamma} = -\gamma$ . In the soft phase ( $\bar{\chi}(y) = -1$ ),

$$\Lambda + \nabla\phi(x) + \nabla\varphi_2(y) = \begin{pmatrix} 2 - \cos\tilde{\gamma} \cos\theta & -\sin\theta & \cos\theta \sin\tilde{\gamma} \\ -\cos\tilde{\gamma} \sin\theta & \cos\theta & \sin\theta \sin\tilde{\gamma} \\ \sin\tilde{\gamma} & 0 & \cos\tilde{\gamma} \end{pmatrix}.$$

Zones 3 and 4. Proceeding as above, one may find  $\varphi_3, \varphi_4 \in W_{\text{per}}^{1,\infty}(Q, \mathbb{R}^3)$  such that for all  $x \in U_3$  and  $y \in (0, 1/2) \times (0, 1)^2$ ,

$$\Lambda + \nabla\phi(x) + \nabla\varphi_3(y) = \begin{pmatrix} \cos\gamma \cos\theta & \sin\theta & -\cos\theta \sin\gamma \\ -\cos\gamma \sin\theta & \cos\theta & \sin\theta \sin\gamma \\ \sin\gamma & 0 & \cos\gamma \end{pmatrix} = R(\tilde{\theta}, \tilde{\gamma})$$

is a rotation, with  $\tilde{\theta} = -\theta, \tilde{\gamma} = -\gamma$ ; and for all  $x \in U_4$  and  $y \in (0, 1/2) \times (0, 1)^2$ ,

$$\Lambda + \nabla\phi(x) + \nabla\varphi_4(y) = \begin{pmatrix} \cos\gamma \cos\theta & -\sin\theta & \cos\theta \sin\gamma \\ \cos\gamma \sin\theta & \cos\theta & \sin\theta \sin\gamma \\ -\sin\gamma & 0 & \cos\gamma \end{pmatrix} = R(\theta, \gamma)$$

is a rotation.

Finally, we are in position to conclude the proof. By using  $\phi$  and  $\varphi$  defined above as test-functions, one obtains

$$\mathcal{Q}W_{\text{cell}}^\eta(\Lambda) \leq \int_U \int_Q W^\eta(y, \Lambda + \nabla\phi(x) + \nabla_y\varphi(x, y)) dy dx \leq \eta c,$$

where  $c = \max(W(C_i))/2$  and  $\{C_i\}_i$  is the finite set of values taken by  $\Lambda + \nabla\phi(x) + \nabla_y\varphi(x, y)$  in the soft phase.  $\square$

#### ACKNOWLEDGMENTS

M. Barchiesi wishes to thank Andrea Braides, Giovanni Leoni and Enzo Nesi for their useful comments and suggestions. A. Gloria gratefully thanks Andrea Braides and Stefan Müller for stimulating discussions. The research of M. Barchiesi was supported by the Center for Nonlinear Analysis (NSF Grants No. DMS-0405343 and DMS-0635983). The research of A. Gloria was supported by the Hausdorff Center for Mathematics. He also acknowledges the support from the Marie Curie Research Training Network MRTN-CT-2004-505226 ‘Multi-scale modelling and characterisation for phase transformations in advanced materials’ (MULTIMAT).

#### REFERENCES

- [1] R. Alicandro and M. Cicalese. A general integral representation result for the continuum limits of discrete energies with superlinear growth. *SIAM J. Math. Anal.*, 36:1–37, 2004.
- [2] R. Alicandro, M. Cicalese, and A. Gloria. Mathematical derivation of a rubber-like stored energy functional. *C. R. Acad. Sci. Paris, Série I*, 345(8):479–482, 2007.
- [3] R. Alicandro, M. Cicalese, and A. Gloria. Integral representation results for energies defined on stochastic lattices and application to nonlinear elasticity. In preparation.
- [4] J.-F. Babadjian and M. Barchiesi. A variational approach to the local character of G-closure: the convex case. *Annales de l’institut Henri Poincaré: Analyse non linéaire*, 2008. To appear.
- [5] J.M. Ball and R.D. James. Fine mixtures as minimizers of energy. *Arch. Rat. Mech. Anal.*, 100:13–52, 1987.
- [6] J. M. Ball & R. D. James. Proposed experimental tests of a theory of fine microstructure and the two-well problem. *Phil. Trans. Roy. Soc. London A*, 338:389–450, 1992.
- [7] M. Barchiesi. Loss of polyconvexity by homogenization: a new example. *Calc. Var. Partial Differential Equations*, 30:215–230, 2007.
- [8] A. Braides and A. Defranceschi. *Homogenization of Multiple Integrals*, volume 12 of *Oxford Lecture Series in Mathematics and Its Applications*. Oxford University Press, 1998.
- [9] B. Dacorogna. *Direct methods in the calculus of variations*, vol. 78 of *Applied Mathematical Sciences*. Springer, Berlin, 2nd ed., 2008.

- [10] I. Fonseca & G. Leoni. *Modern methods in the Calculus of Variations: Sobolev spaces*. In preparation.
- [11] E. Giusti. *Direct methods in the calculus of variations*. World Scientific Publishing Co. Inc., River Edge, NJ, 2003.
- [12] T. Iwaniec, G. Verchota & A. Vogel. The Failure of Rank-One Connections. *Arch. Rational Mech. Anal.*, 163:125–169, 2002.
- [13] S. Müller. Homogenization of nonconvex integral functionals and cellular elastic materials. *Arch. Rat. Anal. Mech.*, 99:189–212, 1987.
- [14] S. Müller. Variational models for microstructure and phase transitions. In *Calculus of variations and geometric evolution problems (Cetraro, 1996)*, volume 1713 of *Lecture Notes in Math.*, pages 85–210. Springer, Berlin, 1999.
- [15] V. Šverák. New examples of quasiconvex functions. *Arch. Rational Mech. Anal.*, 119:293–300, 1992.
- [16] V. Šverák. On the problem of two wells. volume 54 of *IMA Vol. Appl. Math.*, pages 183–189. Springer, 1993.

(Marco Barchiesi) CNA, CARNEGIE MELLON UNIVERSITY, PITTSBURGH, PA 15213, USA  
*E-mail address:* `marcob@andrew.cmu.edu`

(Antoine Gloria) IAM, UNIVERSITÄT BONN, WEGELERSTR. 10, 53115 BONN, GERMANY  
*E-mail address:* `gloria@iam.uni-bonn.de`