



**HAL**  
open science

# Multiobjective Particle Swarm Optimization for the optimal design of photovoltaic grid-connected systems

Aris Kornelakis

► **To cite this version:**

Aris Kornelakis. Multiobjective Particle Swarm Optimization for the optimal design of photovoltaic grid-connected systems. *Solar Energy*, 2010, 84 (12), pp.2022. 10.1016/j.solener.2010.10.001 . hal-00751652

**HAL Id: hal-00751652**

**<https://hal.science/hal-00751652>**

Submitted on 14 Nov 2012

**HAL** is a multi-disciplinary open access archive for the deposit and dissemination of scientific research documents, whether they are published or not. The documents may come from teaching and research institutions in France or abroad, or from public or private research centers.

L'archive ouverte pluridisciplinaire **HAL**, est destinée au dépôt et à la diffusion de documents scientifiques de niveau recherche, publiés ou non, émanant des établissements d'enseignement et de recherche français ou étrangers, des laboratoires publics ou privés.

Manuscript Number: SE-D-10-00343R1

Title: Multiobjective Particle Swarm Optimization for the optimal design of photovoltaic grid-connected systems

Article Type: Regular Paper

Keywords: Environmental; economic; multiobjective optimization; particle swarm optimization; photovoltaic systems.

Corresponding Author: Mr. Aris kornelakis, M.Sc

Corresponding Author's Institution:

First Author: Aris kornelakis, M.Sc

Order of Authors: Aris kornelakis, M.Sc

Abstract: Particle Swarm Optimization (PSO) is a highly efficient evolutionary optimization algorithm. In this paper a multiobjective optimization algorithm based on PSO applied to the optimal design of photovoltaic grid-connected systems (PVGCSs) is presented. The proposed methodology intends to suggest the optimal number of system devices and the optimal PV module installation details, such that the economic and environmental benefits achieved during the system's operational lifetime period are both maximized. The objective function describing the economic benefit of the proposed optimization process is the lifetime system's total net profit which is calculated according to the method of the Net Present Value (NPV). The second objective function, which corresponds to the environmental benefit, equals to the pollutant gas emissions avoided due to the use of the PVGCS. The optimization's decision variables are the optimal number of the PV modules, the PV modules optimal tilt angle, the optimal placement of the PV modules within the available installation area and the optimal distribution of the PV modules among the DC/AC converters.

Dear Editors,

Please find attached the paper entitled "Multiobjective Particle Swarm Optimization for the optimal design of photovoltaic grid-connected systems" by A. Kornelakis, for possible publication in the journal "Solar Energy". If you need anything more, please let me know.

Yours Sincerely,

Aris Kornelakis

## Answers to the Reviewers

The author would like to thank the reviewers for their comments. Their remarks on the current manuscript were highly important and have been taken into consideration for its final formulation. Below, there are answers to their observations. In the marked manuscript the additions to the initially submitted manuscript are marked with yellow color.

### **Reviewer #1:**

*There are no parameters which is satisfied to both economical and environmental viewpoint. Therefore, those parameters are required to be published. (page 14)*

As mentioned in the 5<sup>th</sup> paragraph the objective functions proposed in the current methodology are mutually competitive. The result of this competitiveness is the variances of the basic parameters between the optimal solutions of the respective single-objective optimization problems (Table 2). Otherwise, the multiobjective optimization procedure presented would not be meaningful. The following text has been added in the page 14: “It is also profound that there are many differences between the system parameters of the two resulting cases described above, which is expected, since the single-objective environmental optimization actually is identical to the maximization of the system’s energy production, while the economic optimization refers to the total net profit maximization, including several costs, which often results in a totally different system structure.”

*More precise parameters is required to this paper. It is ambiguous for readers to understand. (page 15)*

In this page, the Pareto fronts are shown as computed by several implemented algorithms. The figures show the Pareto optimal points (solutions) relatively to the corresponding resulting PVGCS’s NPV and the GHG emissions avoided due to its operation. The text of this page was altered as following: “In Figs. 3 – 8 the Pareto front calculated by the application of the MOPSO1, MOPSO2, MOPSO3, MOPSO4, MOPSO5 & MOPSO6 variants are shown. More specifically, following figures depict the Pareto optimal PVGCS solutions, relatively to the respective economic and environmental benefits of each solution. The proposed algorithms were applied for 2000 iterations.”

*More precise explanations for algorithm is required to this paper. It is very difficult for me to understand your simulation parameters.*

The following text has been added on page 4, in order to make more obvious the algorithm's procedure: "After inserting the inputs of the current methodology, the PV energy production data is computed as described above. Afterwards, a multiobjective PSO algorithm is applied for the production of several resulting PVGCSs using appropriate multiobjective methods and the system models incorporated for the estimation of the objective functions (net profits and environmental benefits) of each new solution."

**Reviewer #2:**

*Paper seems to be too lengthy. The authors may be asked to shorten the length of paper.*

Several parts of the current manuscript have been removed as it is longer than usual. Though, it is requisite to provide the reader the ability to understand well every relative aspect considering that in this paper many different fields are involved (PVGCS design, multiobjective optimization theory, evolutionary algorithms etc).

**Reviewer #3:**

*Section 3: The history in developments of PSO algorithm may be limited/reduced. Kindly formulate the discussion on optimization in reference to PVGCS. Otherwise, the paper is well written, presented and may be considered for publication.*

Unfortunately, there are only a few PVGCS design optimization methodologies based on multicriteria or multiobjective processes and they are referred in Paragraph 1. In this paper except for the application of this kind of methods, several multiobjective algorithms have also been implemented and are proposed. Consequently, it is difficult to avoid references to the most widely used multiobjective PSO methodologies currently used. However, several comments on the PSO algorithm and its evolution, generally, have been removed from this section, as remarked.

# Multiobjective Particle Swarm Optimization for the optimal design of photovoltaic grid-connected systems

Aris Kornelakis\*

Technical University of Crete, Department of Electronic and Computer Engineering, University Campus, 73100, Chania, Greece, [akornelakis@gmail.com](mailto:akornelakis@gmail.com)

\*(Corresponding author (A. Kornelakis): E-mail address: [akornelakis@gmail.com](mailto:akornelakis@gmail.com), Tel.: +30-2810-210265)

## Abstract

Particle Swarm Optimization (PSO) is a highly efficient evolutionary optimization algorithm. In this paper a multiobjective optimization algorithm based on PSO applied to the optimal design of photovoltaic grid-connected systems (PVGCSs) is presented. The proposed methodology intends to suggest the optimal number of system devices and the optimal PV module installation details, such that the economic and environmental benefits achieved during the system's operational lifetime period are both maximized. The objective function describing the economic benefit of the proposed optimization process is the lifetime system's total net profit which is calculated according to the method of the Net Present Value (NPV). The second objective function, which corresponds to the environmental benefit, equals to the pollutant gas emissions avoided due to the use of the PVGCS. The optimization's decision variables are the optimal number of the PV modules, the PV modules optimal tilt angle, the optimal placement of the PV modules within the available installation area and the optimal distribution of the PV modules among the DC/AC converters.

**Keywords:** Environmental, economic, multiobjective optimization, particle swarm optimization, photovoltaic systems.

## 1. Introduction

The energy produced by conventional energy sources results in increased Green House Gas (GHG) emissions which, if not drastically reduced, threaten the global climate's stability. The disadvantage of the fossil fuels described above combined with the depletion of their reserves and the rapid growth of the energy demands has led to the exploitation of benign sources of energy, such as Renewable Energy Sources (RES). Those alternative energy production systems, such as Photovoltaic (PV) systems are being supported by many governments on a worldwide basis by means of subsidization of the initial capital invested on them. The photovoltaic grid-connected systems (PVGCSs) are used to supply the local electric grid with the total energy produced by PV

modules. The investment on the installation of PVGCSs is further supported by providing high selling prices of the generated energy from the PV modules, as a significant form of RES applications.

As shown in Fig.1 a PVGCS is comprised of several DC/AC converters while every DC/AC converter's DC input is connected with a PV array which consists of a number of parallel branches of PV modules, while each branch includes several PV modules connected in series.

Fig. 1.

The PVGCS sizing ratio, which is equal to the quotient of the nominal power of the PV array to the nominal power of the total DC/AC converters, is investigated in [1] and [2]. In [1] the optimal sizing ratio is examined through the the TRNSYS simulation tool for several components costs and solar irradiation scenarios. The PVGCS sizing ratio, for which the total system cost is being minimized, is considered to be affected by the solar irradiation conditions at the installation site and the efficiency of the DC/AC converters. In [2] the PVGCS sizing ratio, is investigated in order to minimize the total system cost. Through simulations of the system operation for several locations in Europe and USA it can be concluded that the optimal ratio depends on the DC/AC converter technical characteristics, the orientation of the PV modules and the costs of the system's devices. A methodology for the optimal selection of the PVGCS installation site is presented in [3]. The selection of optimal installation site of the PVGCSs is implemented by decision-support systems incorporating multi-criteria analysis and analytic hierarchy process together with geographical information systems (GIS) technology, taking into account environmental, location, topographic and climate factors. A methodology for the optimal sizing of PVGCSs is proposed in [4]. This methodology reaches the best compromise between technical and economic aspects using a multiobjective optimization approach. The technical impacts are related to the improvement of the voltage stability due to the stochastic PV energy production variation. The economic objectives are related to the PVGCS economic profitability and the cost of the feeder power losses. A method for the optimal design and the economic analysis of PVGCSs is presented in [5]. As shown, the profitability and the design of the PVGCS can be significantly influenced by factors such as the cost of land required for the installation, the subsidization rate and the selling price of the produced energy. The objective of this methodology is the maximization of the system's Net Present Value, while the optimal solutions are explored using a Particle Swarm Optimization (PSO) approach.

However, most of the design methodologies described above do not take into account several important factors, such as the PV modules tilt angle value, the costs of the installation's land and the

1 construction of the PV modules mounting structures and economic parameters such as the taxation  
2 rate of the economic receipts, which can highly influence the design procedure. Moreover, the  
3 optimization methodologies are often implemented using conventional programming techniques,  
4 which do not guarantee convergence to the optimal solution.

5 In this paper, a methodology for the design optimization of PVGCSs is presented intending to  
6 suggest the optimal values of the PVGCSs installation details such as the number of the PV modules  
7 and the DC/AC converters, the PV modules optimal tilt angle, the optimal placement of the PV  
8 modules within the installation land and the optimal distribution among the DC/AC converters. The  
9 design optimization aims towards the maximization of both the economic and environmental  
10 benefits received by the use of PVGCSs. For this reason, a multiobjective technique based on PSO  
11 approach, with several variations, has been developed and is presented in this paper. The proposed  
12 multiobjective algorithm was applied to the proposed methodology for the concurrent optimization  
13 of the objective functions representing the system's benefits subject to maximization. Compared to  
14 conventional optimization methods this evolutionary technique of PSO is able of exploring the  
15 problem's search space with lower computational complexity, especially in cases of complicated and  
16 non-linear objective functions or constraints, like the current problem.  
17  
18  
19  
20  
21  
22  
23  
24  
25  
26  
27  
28

## 29 **2. The proposed methodology and the system models involved**

30

31 The proposed methodology's algorithm initiates by the insertion of the case study's inputs  
32 containing the technical and economic characteristics of commercially available devices (PV  
33 modules and DC/AC converters) along with meteorological data collected for the selected for the  
34 installation site and a series of economic parameters. The economic characteristics of the system's  
35 devices are the installation and annual maintenance costs per unit. The rest of parameters loaded  
36 from the database are the hourly solar irradiation and ambient temperature values during the year, the  
37 available area dimensions, the local economy's parameters and finally, parameters used for the  
38 computation of the cost of the land and the mounting structures of PV modules. In order to take into  
39 account detailed parameters of the installation's structure during the PVGCS multiobjective  
40 optimization, several models have been incorporated, describing the distribution of the PV modules  
41 among the system's DC/AC converters, their arrangement into the available area and the estimated  
42 cost of the PV modules' mounting structures, proposed in [5].  
43  
44  
45  
46  
47  
48  
49  
50  
51  
52  
53

54 The methodology described in this paper is applicable for PVGCSs and, therefore, it is considered  
55 that the total energy produced is injected to the electric grid. The produced energy is calculated on an  
56 hourly basis for a one-year time period and the calculated annual PVGCS energy production is  
57 assumed to be constant during the system's operational lifetime. The output power of the selected  
58  
59  
60  
61  
62  
63  
64  
65



PV module on day  $d$  ( $1 \leq d \leq 365$ ) and at hour  $t$  ( $1 \leq t \leq 24$ ),  $P_M^d(t, \beta)$  (W), is calculated as described by E. Lorenzo [6]. The PV modules tilt angle,  $\beta$  ( $^\circ$ ), is considered to be constant during the year.

As shown in Fig. 1, each PV array consists of  $N_p$  parallel branches of PV modules ( $N_p \geq 1$ ), while each branch consists of  $N_s$  PV modules connected in series ( $N_s \geq 1$ ). The utilized modeling figures the required number of DC/AC converters for a PVGCS of a total number of PV modules equal to  $N_l$  and distributes the  $N_l$  PV modules to the system's DC/AC converters. The attainable distribution described is implemented by using the values of the minimum and maximum input voltage and the maximum input power for the selected DC/AC converter type, as well as the output voltage and power at the Maximum Power Point (MPP) for the selected PV module type.

The PV modules are arranged within the area in multiple rows facing south, where each row is comprised of multiple lines,  $N_2$ . The arrangement details are calculated according to [5], while the adequate distance between adjacent rows,  $F_y$ , in order to eliminate the mutual shading of the PV modules during each hour of the year is calculated as described in [7]. The dimensions of the useful area finally occupied by PV modules,  $D_1$  (m) and  $D_2$  (m), are also calculated as proposed in [5].

In order to incorporate the cost of the PV module mounting structures in the optimal sizing procedure, a generalized model has been used [5]. The mounting structures are manufactured using metallic spars. The calculation of the corresponding cost is based on the calculation of the total raw materials required. The specific model's outputs are the total length of the metallic spars,  $B$  (m), required for the installation of the entire PVGCS and the total volume of the concrete bases,  $B_B$  ( $\text{m}^3$ ). The total cost of the mounting structures,  $C_B$  (€), is equal to the sum of the metallic spars and the concrete foundation bases costs:

$$C_B = B \cdot c_S + B_B \cdot c_B \quad (1)$$

where  $c_S$  (€/m) is the cost per length of the metallic spars and  $c_B$  (€/m<sup>3</sup>) is the cost per volume of the concrete bases. The value of  $c_S$  typically depends on the required thickness of the construction material and is specified by the designer.

After inserting the inputs of the current methodology, the PV energy production data is computed as described above. Afterwards, a multiobjective PSO algorithm is applied for the production of several resulting PVGCSs using appropriate multiobjective methods and the system models incorporated for the estimation of the objective functions (net profits and environmental benefits) of each new solution.

### 3. The proposed multiobjective PSO algorithm

The PSO algorithm is a stochastic optimization technique based on the evolution of a population of solutions. It was proposed by Eberhart and Kennedy [8] as an alternative method to the Genetic Algorithms (GAs) inspired by the social behavior of the bird swarms. The basic PSO algorithm for the calculation of the next position of the particle is:

$$v_{i+1}(j) = v_i(j) + c_1 \cdot r_{1,i}(j) \cdot [pbest(j) - x_i(j)] + c_2 \cdot r_{2,i}(j) \cdot [gbest(j) - x_i(j)] \quad (2)$$

$$x_{i+1}(j) = v_{i+1}(j) + x_i(j) \quad (3)$$

where  $i$  is the number of iteration,  $j$  is the variable of the optimization vector,  $x_i(j)$  is the value of the variable  $j$  at the iteration  $i$ ,  $v_i(j)$  is the velocity of the variable  $j$  at the iteration  $i$ ,  $c_1$  and  $c_2$  are constant variables usually set equal to 2,  $r_{1,i}$  and  $r_{2,i}$  are random variables in the range [0,1],  $pbest(j)$  is the value of the variable  $j$  of the best solution of the specific particle up to the iteration  $i$  and  $gbest(j)$  is the value of the variable  $j$  of the best solution located by the swarm up to the iteration  $i$ . Eberhart et al. [9] proposed the limiting of the speed of each particle to a range  $[-v_{max}, v_{max}]$  in order to reduce the possibility of particle flying out of the problem's space. Shi and Eberhart [11] noted that the lack of the velocity memory ( $v_i(j)$  in (2)) the swarm results in cramping at the global best solution found within the initial swarm. In contrary, the velocity memory pushes the swarm to behave oppositely, providing a global search. In order to balance between exploration and exploitation a modified PSO algorithm, incorporating an inertia weight,  $w$ , was introduced thus:

$$v_{i+1}(j) = w \cdot v_i(j) + c_1 \cdot r_{1,i}(j) \cdot [pbest(j) - x_i(j)] + c_2 \cdot r_{2,i}(j) \cdot [gbest(j) - x_i(j)] \quad (4)$$

In [11] it is proposed that the value of  $w$  is initially set to 0.9 reducing linearly to 0.4 during a number of optimization iterations. Constriction is a substitutional way of controlling the behavior of particles. Instead of applying inertia weight to the velocity memory, in [12] a method known as Constriction PSO (CPSO), incorporating a constriction factor,  $\chi$ , to the new velocity is presented:

$$v_{i+1}(j) = \chi \cdot \{v_i(j) + c_1 \cdot r_{1,i}(j) \cdot [pbest(j) - x_i(j)] + c_2 \cdot r_{2,i}(j) \cdot [gbest(j) - x_i(j)]\} \quad (5)$$

Where  $\chi$  is the constriction factor calculated is following:

$$\chi = \frac{2}{\left|2 - c - \sqrt{c^2 - 4 \cdot c}\right|} \quad (6)$$

and  $c$  is equal to  $c = c_1 + c_2, c > 4$ .

When optimizing two or more competitive objective functions together, the arising problem is the definition of a model satisfying the conflicting objective functions. This problem is called multiobjective optimization. In multiobjective optimization, the solution is chosen from a set of solutions called Pareto front [13]. Given two vectors  $y_1^*$  and  $y_2^*$  where  $y_1^* = [y_{1,1}, y_{1,2} \dots y_{1,k}]$ ,  $y_2^* = [y_{2,1}, y_{2,2} \dots y_{2,k}]$ ,  $k$  is the number of the problem's objective functions and  $y_{1,i}, y_{2,i}$  are the values of the  $i$ -th objective function for the two vectors, respectively. If each objective function is subject to maximization and  $y_{1,i} \geq y_{2,i}, \forall i \in [1, k]$  then it is considered that  $y_1^*$  dominates  $y_2^*$  ( $y_1^* \succ y_2^*$ ). A vector  $y_1^*$  is called Pareto optimal if it is not dominated by any other feasible solution. Several methods have been proposed for the multiobjective optimization using PSO that are, generally, based on the concept of Pareto dominance.

In [14] an algorithm that sums the problem's objective functions in one is presented in three different ways. The first approach includes a linear combination with coefficients determined during the algorithm's execution, the second approach a dynamic combination function with gradually altering weights and, finally, the third approach includes a combination function with suddenly altering weights (bang bang aggregation approach). The sharing of the population members in equally sized sub-populations is proposed in [15]. In each subpopulation a linear combination of the objective functions is used with different weights and evolves following the best solution emerging between its members. In [16] and [17] an algorithm which optimizes each objective function separately according to the ranking of their importance, is presented. In [18] the simultaneous optimization of the objective functions is applied using a corresponding number of swarms that exchange information relative with the best solutions located. This algorithm is called VEPSO, inspired from a Genetic Algorithms (GAs) approach. In [19] the multi-species PSO is proposed where the multiobjective optimization problem is treated as a problem of single objective functions, each one corresponding to a sub-swarm. Like in the previous approach, the populations communicate by sending the characteristics of their best particles. A scheme based on Pareto dominance is presented in [20]. In this methodology the combination of the searching process and the personal best solutions of the particles (pbest vectors) is of high importance. The personal best solution of each particle is considered to be randomly chosen from a list with the total non-dominated solutions located by the specific particle. In [21] an approach is presented where all the non-dominated solution located are stored in a structure from which the nearest solution is chosen as

1 the global best solution for the application of the PSO algorithm. Moreover, a “mutation” operator is  
2 used to affect PSO’s velocity vector. In [22] the dominance theory is used to direct the particles,  
3 using clustering techniques for the division of the subpopulation aiming towards the dispersion of  
4 the particles in the search space. The “Particle Swarm Inspired Evolutionary Algorithm” (PS-EA) is  
5 presented in [23]. This method is a hybrid PSO and evolutionary algorithm based on the competition  
6 between the operators of the two methods. The proposed algorithm includes mutation and selection  
7 operators that utilize the Pareto ranking. In [24] the coveringMOPSO (cvMOPSO) algorithm is  
8 presented. The operation of the cvMOPSO is divided in two phases. Initially, the Pareto front is  
9 being reached approximately and then, the population is being distributed around the solutions of the  
10 existing front. The investigators of this method claim that this is a way of better exploration of the  
11 dominant solutions. In [25] the application of PSO is proposed together with the use of several  
12 methods for the insertion or the deletion of Pareto solutions. The methods presented are related to  
13 the diversity of the solutions of the existing Pareto front. The method proposed in [26] involves  
14 mechanisms of combination of the whole population’s members together with their personal best  
15 solutions into a united population from which only the non-dominated solutions are chosen for the  
16 next swarm. Moreover, the personal best solution of each particle is selected randomly from a list  
17 with all the non-dominated solutions located by the specific particle. Several modifications of the  
18 PSO algorithm are proposed in [27]. The dependence between the random factors ( $r_{1,i}$  and  $r_{2,i}$ ) and  
19 the application of a weighting factor to the second and the third component of the PSO equation are  
20 among the changes proposed. Also, the storing of all the non-dominated solutions found by each  
21 particle is proposed. The deletion of Pareto solutions and the choice of the global optimal solution  
22 for the particles according to a probability density function are presented in [28]. The Pareto front is  
23 being ranked by taking into account the density of members in each solution’s area and the global  
24 optimal solution is chosen randomly from its top. In [29] the clustMPSO algorithm is presented. The  
25 specific approach combines clustering techniques with PSO methods and divides the population to  
26 subsets. The final Pareto front is the join of the separate fronts emerging in each sub-swarm. The  
27 specific algorithm was applied to the multiobjective optimization of biochemistry problem.

28  
29  
30  
31  
32  
33  
34  
35  
36  
37  
38  
39  
40  
41  
42  
43  
44  
45  
46  
47  
48  
49  
50  
51  
52  
53  
54  
55  
56  
57  
58  
59  
60  
61  
62  
63  
64  
65  
In this paper, an alternative PSO algorithm is proposed for the optimization of multiobjective problems. The proposed algorithm starts with the random initialization of the initial population. The repairing algorithm is applied for the correction of the initial particles that violate the problem’s constraints. The repairing algorithm developed modifies the values of the decision variables of those particles such that all of constraints are fully satisfied. The constraints refer to the feasibility of the arrangement of the PV modules into the available land area, the distribution of the PV modules among the system’s DC/AC Converters and the values range of each decision variable and are examined through appropriate simulation algorithms. The feasible swarm is then evaluated by each

objective function separately and the corresponding values are stored, while a global best solution  $gbest_k$  arises for each one of the  $k$  objective functions. Afterwards, the  $pbest_k$  vectors are being initialized for every single objective function. The algorithm's initialization process ends with the creation of the initial Pareto set with the non-dominated solutions inside the initial swarm. When the computations described above are completed, the iterative procedure starts with the application, initially, of the multiobjective PSO algorithm which its velocity equation is a variation of either the simple PSO method (2) or the inertia PSO (4) or the CPSO method (5). The resulting variants are named MOPSO1, MOPSO2 and MOPSO3, respectively, and are described by the following equations:

$$v_{i+1}(j) = v_i(j) + c_1 \cdot r_{1,i}(j) \cdot \frac{\sum_k [pbest_k(j) - x_i(j)]}{k} + c_2 \cdot r_{2,i}(j) \cdot \frac{\sum_k [gbest_k(j) - x_i(j)]}{k} \quad (7)$$

$$v_{i+1}(j) = w \cdot v_i(j) + c_1 \cdot r_{1,i}(j) \cdot \frac{\sum_k [pbest_k(j) - x_i(j)]}{k} + c_2 \cdot r_{2,i}(j) \cdot \frac{\sum_k [gbest_k(j) - x_i(j)]}{k} \quad (8)$$

$$v_{i+1}(j) = \chi \cdot \left\{ v_i(j) + c_1 \cdot r_{1,i}(j) \cdot \frac{\sum_k [pbest_k(j) - x_i(j)]}{k} + c_2 \cdot r_{2,i}(j) \cdot \frac{\sum_k [gbest_k(j) - x_i(j)]}{k} \right\} \quad (9)$$

The new population is, then, formed according to (3). Three other variations of the velocity equation of the proposed multiobjective algorithm are, also, presented in this paper. The basic difference from the variants described above lies on the formation of the third component of the PSO algorithm (related with the global optimal solutions). In particular, in these variants, the global optimal solution's values are being replaced by the values  $gbest_r(j)$  of a randomly chosen member of the existing Pareto set, up to the instant iteration. In these variants, the velocity equations could also be variations of either the simple PSO method (2) or the inertia PSO (4) or the CPSO method (5). The resulting variants are named MOPSO4, MOPSO5 and MOPSO6, respectively, and are described by the following equations:

$$v_{i+1}(j) = v_i(j) + c_1 \cdot r_{1,i}(j) \cdot \frac{\sum_k [pbest_k(j) - x_i(j)]}{k} + c_2 \cdot r_{2,i}(j) \cdot [gbest_r(j) - x_i(j)] \quad (10)$$

$$v_{i+1}(j) = w \cdot v_i(j) + c_1 \cdot r_{1,i}(j) \cdot \frac{\sum_k [pbest_k(j) - x_i(j)]}{k} + c_2 \cdot r_{2,i}(j) \cdot [gbest_r(j) - x_i(j)] \quad (11)$$

$$v_{i+1}(j) = \chi \cdot \left\{ v_i(j) + c_1 \cdot r_{1,i}(j) \cdot \frac{\sum_k [pbest_k(j) - x_i(j)]}{k} + c_2 \cdot r_{2,i}(j) \cdot [gbest_r(j) - x_i(j)] \right\} \quad (12)$$

After the application of a variant of the multiobjective PSO algorithm, the repairing algorithm is applied and every particle is evaluated according to each objective function, separately, while the  $pbest_k$  vectors are being updated. At the end of each iteration, the Pareto set is being updated by adding new dominant solutions or removing previous Pareto solutions that are dominated by newly generated members of the current population. The population's size remains constant during the algorithm's execution, while the size of the Pareto set changes dynamically. After a specific predefined number of iterations, the proposed multiobjective algorithm gives the located Pareto front. In Fig. 2 the flowchart of the proposed multiobjective PSO algorithm is shown.

#### 4. The objective functions of the multiobjective maximization process

In the proposed method, the decision variables used during the optimization procedure are  $N_1$ ,  $N_2$  and  $\beta$ . The optimal total number of DC/AC converters and the distribution of the PV modules among them, the dimensions of the required area and the optimal placement of the PV modules into the available area are calculated using the optimal values of the three decision variables. The multiobjective problem involves the maximization of two objective functions, representing the economic and the environmental benefits arising due to the installation of the PVGCS.

Fig. 2.

The first objective function subject to maximization is the PVGCS total net profit function,  $f_1(\mathbf{x})$  (€), and is calculated according to the widely used methodology of NPV:

$$f_1(\mathbf{x}) = P_E(\mathbf{x}) - C_c(\mathbf{x}) - C_m(\mathbf{x}) \quad (13)$$

where  $\mathbf{x}$  represents the vector of the decision variables,  $P_E(\mathbf{x})$  (€) represents the total profits achieved during the system's lifetime period,  $C_c(\mathbf{x})$  (€) is the total capital and  $C_m(\mathbf{x})$  (€) the total maintenance cost. The total net profit achieved during the PVGCS operational lifetime period depends on the amount of energy generated by the system's PV modules and on the price that the energy produced by the PVGCS is sold to the electric grid and not on the price that the electric grid customers purchase the electric energy from the electric grid operator in order to fulfil their energy requirements, or the corresponding load profile.

The total capital cost,  $C_c(\mathbf{x})$ , is calculated as follows:

$$C_c(\mathbf{x}) = \left(1 - \frac{s}{100}\right) \cdot (N_I \cdot C_{PV} + N_{dc} \cdot C_{INV} + C_L + C_B) \quad (14)$$

where  $s$  (%) is the subsidization rate,  $C_{PV}$  (€) and  $C_{INV}$  (€) are the capital costs of each PV module and DC/AC converter, respectively,  $N_{dc}$  is the number of the DC/AC converters required for the installation of  $N_I$  PV modules, calculated according to [5],  $C_L$  (€) is the cost of the installation area and  $C_B$  (€) is the cost of the mounting structures (1).

The cost of the required installation area,  $C_L$ , is calculated as follows:

$$C_L = D_1 \cdot D_2 \cdot c_l \quad (15)$$

where  $c_l$  is the cost of the land per unit (€/m<sup>2</sup>).

The present value of the maintenance cost,  $C_m(\mathbf{x})$ , during the PVGCS operational lifetime period is calculated using the following equation:

$$C_m(\mathbf{x}) = (N_I \cdot M_{PV} + N_{dc} \cdot M_{INV}) \cdot (1 + g) \cdot \left[ \frac{1 - \left(\frac{1+g}{1+i}\right)^n}{i - g} \right] + R_{TC} \quad (16)$$

where  $M_{PV}$  and  $M_{INV}$  (€/year) are the annual maintenance costs per unit of the PV modules and the DC/AC converters, respectively,  $g$  (%) is the annual inflation rate,  $i$  (%) is the nominal annual discount rate and  $R_{TC}$  (€) is the present value of the total cost of repairing the PVGCS DC/AC converters:

$$R_{TC} = N_{dc} \cdot R_{cost} \cdot \left[ \sum_{\forall j=k^*} \frac{(1+g)^j}{(1+i)^j} \right] \quad (17)$$

where  $k^*$  are the year numbers that the DC/AC converters must be repaired and  $R_{cost}$  (€) is the cost of each DC/AC converter repairing.

The  $k^*$  values depend on the number of repairs during the PVGCS lifetime,  $N_r$ , which is calculated as follows:

$$N_r = \frac{n \cdot 24 \cdot 365}{MTBF} \quad (18)$$

where  $MTBF$  (h) is the mean time between failures of the DC/AC converters.

The present value of the total profits achieved from selling the PV generated energy to the electric grid,  $P_E(\mathbf{x})$  (€), is calculated as follows:

$$P_E(\mathbf{x}) = \left(1 - \frac{tax}{100}\right) \cdot C_o \cdot N_1 \cdot E_{tot} \cdot \frac{\left(1 - \left(\frac{1}{1+i}\right)^n\right)}{i} \quad (19)$$

$$E_{tot} = n_{INV} \cdot n_{MPPT} \cdot \sum_{d=1}^{365} \sum_{i=1}^{24} \frac{P_M^d(t, \beta)}{1000 \text{ W/kW}} \cdot \Delta t \quad (20)$$

where  $tax$  (%) represents the taxation rate of the profits,  $C_o$  (€/kWh) is the energy selling price,  $E_{tot}$  (kWh) is the total annual energy generated by each PV module,  $\Delta t$  is the simulation time step, set to  $\Delta t = 1$  hour,  $n_{INV}$  is the DC/AC converter's efficiency and  $n_{MPPT}$  is a conversion factor indicating the MPPT accuracy of the DC/AC converter.

The second objective function subject to maximization is the PVGCS total environmental benefit function,  $f_2(\mathbf{x})$  (kg CO<sub>2</sub>), describing the total CO<sub>2</sub> emissions avoided due to the use of the PVGCS according to the method of Life Cycle Assessment (LCA) [30]:

$$f_2(\mathbf{x}) = E_{conv}(\mathbf{x}) - E_{PVGCS}(\mathbf{x}) - E_{inst}(\mathbf{x}) \quad (21)$$

where  $E_{conv}(\mathbf{x})$  describes the CO<sub>2</sub> emissions released by a conventional energy generation system for the production of the total energy estimated to be generated by the PVGCS,  $E_{PVGCS}(\mathbf{x})$  describes the CO<sub>2</sub> emissions released by the PVGCS and  $E_{inst}(\mathbf{x})$  describes the CO<sub>2</sub> emissions released during the production and installation of the structure of the PVGCS. The CO<sub>2</sub> emissions released by a conventional energy generation system,  $E_{conv}(\mathbf{x})$  (kg CO<sub>2</sub>), are calculated as follows:

$$E_{conv}(\mathbf{x}) = N_1 \cdot E_{tot} \cdot f_{conv} \quad (22)$$

where  $f_{conv}$  (kg CO<sub>2</sub> per kWh) is a factor indicating the estimated CO<sub>2</sub> emissions released by a conventional energy source system per energy unit. In Table 1, the value of this factor for several



conventional sources is shown [31]. The CO<sub>2</sub> emissions released by a PV system,  $E_{PVGCS}(\mathbf{x})$  (kg CO<sub>2</sub>), are calculated as follows:

$$E_{PVGCS}(\mathbf{x}) = N_1 \cdot E_{tot} \cdot f_{PV} \quad (23)$$

where  $f_{PV}$  (kg CO<sub>2</sub> per kWh) is a factor indicating the estimated CO<sub>2</sub> emissions released by a PV system per energy unit. The corresponding value is equal to 0.098 kg/kWh according to [31]. The CO<sub>2</sub> emissions released during the production and installation of the devices of a PV system,  $E_{inst}(\mathbf{x})$  (kg CO<sub>2</sub>), are calculated as follows:

$$E_{inst}(\mathbf{x}) = P_{Peak} \cdot f_{prod} \quad (24)$$

where  $f_{prod}$  (kg CO<sub>2</sub> per kWp) is a factor indicating the estimated CO<sub>2</sub> emissions released during the production and installation of a PV system per installed power unit and  $P_{Peak}$  (kWp) is the PVGCS installed power equal to :

$$P_{Peak} = P_{PV} \cdot N_1 / 1000 \quad (25)$$

where  $P_{PV}$  (W) is the nominal power of the selected PV module, according to the specifications of its manufacturer. The value of  $f_{prod}$  can be set equal to 1392.1 kg CO<sub>2</sub> per kWp according to [32].

**Table 1**

Carbon	Oil	Natural Gas	Diesel
955	818	430	772

The CO<sub>2</sub> emissions per energy unit (kg/kWh) for several conventional energy sources

## 5. Results

The methodology described in the previous sections has been applied for the optimal design of PVGCSs joint to the electric network of the island of Crete. The daily global solar irradiation on horizontal plane and the hourly mean ambient temperature data that were recorded at the area of the Technical University of Crete (latitude: 35°). According to the current local market prices, the cost of the metallic spars,  $c_s$ , was set equal to 33€/m and the cost of the concrete foundation bases,  $c_B$ , was set equal to 230€/m<sup>3</sup>. The annual inflation rate,  $g$ , was set equal to 4% and the nominal annual

discount rate,  $i$ , was set equal to 8%. According to the Greek legislation, the selling price of the energy produced by the PVGCS has been set to  $C_o = 0.50\text{€} / kWh$  for systems with total installed PV modules power up to 100kW and to  $C_o = 0.45\text{€} / kWh$  for systems with higher installed power. Also, the PVGCS operational lifetime period has been set equal to 25 years. The main energy source for the island of Crete is considered to be the oil, with a corresponding value of CO<sub>2</sub> emissions per energy unit equal to  $f_{conv} = 0.818$  kg CO<sub>2</sub> per kWh. In Table 2, the optimal sizing results according to the objective functions of the environmental and the economic benefits, separately, are shown. The upper limits of the decision variables  $N_1$  and  $N_2$  were set equal to  $N_1^U = 5\ 000$  and  $N_2^U = 100$  while the dimensions of the available land are set equal to  $DIM_1 = 10m$  (southern side) and  $DIM_2 = 100m$  (western side). The results shown, were generated for subsidization rate equal to  $s = 0\%$ , taxation rate equal to  $tax = 0\%$  and cost of the installation area equal to  $c_l = 0\text{€} / m^2$ . The NPV ( $f_1$ ) is presented together with the total cash inflows, the total expenses, the discounted payback time ( $n^*$ ) [5] and the Internal Rate of Return (IRR) [5] of the proposed PVGCS.

**Table 2**

	Optimal PVGCS according to environmental benefit	Optimal PVGCS according to economic benefit
$N_1$	684	576
$N_2$	100	12
$\beta$	27°	8°
$N_{dc}$	19	16
$f_1(NPV)$	288 270.77€	544 565.07€
$C_c(x)$	747 597.27€	396 433.79€
$C_m(x)$	69 512.96€	65 982.35€
$P_E(x)$	1 105 381€	1 006 981.21€
$n^*$	12.3 years	5.7 years
<b>IRR</b>	13%	22%
$f_2$	3 980 155 kg CO <sub>2</sub>	3 259 665 kg CO <sub>2</sub>
$E_{conv}(x) - E_{PVGCS}(x)$	4 142 029 kg CO <sub>2</sub>	3 395 979 kg CO <sub>2</sub>
$E_{inst}(x)$	161 873 kg CO <sub>2</sub>	136 314 kg CO <sub>2</sub>

The PVGCS optimal structure and analysis according to either environmental or economic benefits in case that  $s = 0\%$ ,  $c_1 = 0 \text{ €/m}^2$ , tax = 0%,  $DIM_1 = 10\text{m}$ ,  $DIM_2 = 100\text{m}$ .

As shown in Table 2, the single-objective design optimization of the PVGCS according to environmental and economic benefits, separately, results in two totally different system structures. Also, the values of the objective functions for the two resulting systems are very different (e.g. the NPV of the optimal system according to the economic benefits is about two times higher than the NPV of the optimal system according to the environmental benefits). It is also profound that there are many differences between the system parameters of the two resulting cases described above, which is expected, since the single-objective environmental optimization actually is identical to the maximization of the system's energy production, while the economic optimization refers to the total net profit maximization, including several costs, which often results in a totally different system structure. Therefore, it can be concluded that the two objective functions of the proposed PVGCS

methodology are mutually competitive and the multiobjective optimization procedure is of high importance.

The proposed multiobjective PSO variants were applied for the simultaneous multiobjective optimization of the two objective functions, describing the economic and environmental benefits of the PVGCS under design. The results shown below refer to PVGCSs with economic and available land parameters equal to those reported above, for the production of the results presented in Table 2. In Figs. 3 – 8 the Pareto front calculated by the application of the MOPSO1, MOPSO2, MOPSO3, MOPSO4, MOPSO5 & MOPSO6 variants are shown. More specifically, following figures depict the Pareto optimal PVGCS solutions, relatively to the respective economic and environmental benefits of each solution. The proposed algorithms were applied for 2 000 iterations. Through sufficient number of trials, it was observed that after this number of iterations, the Pareto front located remains unchangeable.

Fig. 3.

Fig. 4.

Fig. 5.

Fig. 6.

Fig. 7.

Fig. 8.

It can be observed that the MOPSO4, MOPSO5 & MOPSO6 variants, based on the usage of randomly chosen solutions of the existing Pareto sets, fail to explore adequately the Pareto area close to the optimal results according to economic benefits (higher values of  $f_1$ ), while the MOPSO5 variant with the usage of an inertia weight works slightly better. In contrary, the MOPSO1, MOPSO2 & MOPSO3 variants have a better performance, with the MOPSO2 variant, incorporating the usage of an inertia weight, outbalance the two other methods. In Fig. 9, the six variant schemes of the proposed multiobjective PSO technique are compared together for the multiobjective optimal design of the PVGCS described above.

Fig. 9.

As shown in Fig. 9, all of the proposed multiobjective PSO variants locate a satisfactory number of Pareto solutions (usually more than 20), while some of them perform slightly better, as mentioned above. In Fig. 10 the number of Pareto solutions located by the MOPSO2 variant is shown for several numbers of iterations applied. The runtime of the proposed algorithms for the execution of

2 000 iterations does not exceed the total time of two minutes. The PVGCS multiobjective optimal sizing algorithm using PSO was developed using the C++ language and the CPU times referred were gathered using a PC with a 3.0GHz CPU.

Fig. 10.

## 6. Conclusions

The energy crisis due to the increasing energy demands and the pollution caused by conventional energy generating sources have resulted to the wide use of PVGCSs for providing the electric grid with the PV generated energy. In many countries private investors are encouraged to invest on PVGCSs by means of subsidization of the installation's cost. A methodology for the optimal sizing and analysis of the economic and environmental profitability of PVGCSs has been presented in this paper. The purpose of the proposed methodology is to suggest the optimal design parameters of a PVGCS such that the economic and environmental are both maximized. Several variants of a multiobjective algorithm based on PSO have been developed for the optimization of multiple objective functions. The proposed multiobjective PSO variants have been applied for the multiobjective design optimization of PVGCSs. It was observed that the MOPSO2 variant, based on the usage of the mean values of the personal and global best solutions for each objective function and the application of an inertia weight to the PSO velocity equation, outperformed the rest of the proposed multiobjective PSO variations.

According to the optimization results, the multiobjective optimization of the proposed methodology is meaningful, while the proposed multiobjective PSO variants achieve the exploration of the Pareto front and the location of a sufficient number of Pareto optimal solutions, providing multiple alternative PVGCS structures in a very short time.

## References

- [1] J.D. Mondol, Y.G. Yohanis, B. Norton, Optimal sizing of array and converter for grid-connected photovoltaic systems, *Sol. Energy* 80 (2006) 1517–1539.
- [2] K. Peippo, P.D. Lund, Optimal sizing of grid-connected PV-systems for different climates and array orientations: a simulation study, *Sol. Energy Mater. Sol. Cells* 35 (1994) 445-451.
- [3] J.A. Carrion, A.E. Estrella, F.A. Dols, M.Z. Toro, M. Rodríguez, A.R. Ridaó, Environmental decision-support systems for evaluating the carrying capacity of land areas: Optimal site

selection for grid-connected photovoltaic power plants, *Renew. Sust. Energ. Rev.* 12 (2008) 2358-2380.

- [4] A. Medina, J.C. Hernandez, F. Jurado, Optimal placement and sizing procedure for PV systems on radial distribution feeders, *IEEE Int. Conf. Power Syst. Technol.* (2006).
- [5] A. Kornelakis, Y. Marinakis, Contribution for optimal sizing of grid-connected PV-systems using PSO, *Renew. Energ.* 35 (2010) 2143-2398.
- [6] E. Lorenzo, *Solar Electricity: Engineering of photovoltaic Systems*, 1st ed., Progensa, Sevilla, 1994.
- [7] J. Appelbaum, J. Bany, Shadow Effect of Adjacent Solar Collectors in Large Scale Systems, *Solar Energy* 23 (1979) 497-507.
- [8] J. Kennedy, R.C. Eberhart, Particle swarm optimization, *Proc. IEEE Int. Conf. Neural Networks* (1995) 1942–1948.
- [9] R.C. Eberhart, P. Simpson, R. Dobbins, *Computational intelligence PC tools*, CA: AP Professional, San Diego, 1996.
- [10] Y. Shi, R.C Eberhart, A modified particle swarm optimizer, *Proc. IEEE Int. Conf. Evol. Computation* (1998) 69–73.
- [11] R.C. Eberhart, Y. Shi, Comparing Inertia Weights and Constriction Factors in Particle Swarm Optimization, *Proc. IEEE Congr. Evol. Computation* (2000) 84–88.
- [12] M. Clerc, J. Kennedy, The particle swarm: explosion, stability and convergence in a multi-dimensional complex space, *IEEE Trans. Evol. Comput.* 6 (2002) 58–73.
- [13] C.A. Coello Coello, G.B. Lamont, D.A.V. Veldhuizen, *Evolutionary Algorithms for Solving Multi-Objective Problems*, 2nd ed., Springer, New York, 2007.
- [14] K.E. Parsopoulos, M.N. Vrahatis, Particle swarm optimization method in multiobjective problems, *Proc. 2002 ACM Symp. Appl. Computing* (2002) 603–607.
- [15] U. Baumgartner, Ch. Magele, W. Renhart, Pareto optimality and particle swarm optimization, *IEEE Trans. Magn.* 40 (2004) 1172–1175.
- [16] X. Hu, R.C. Eberhart, Multiobjective optimization using dynamic neighborhood particle swarm optimization, *IEEE Congr. Evol. Computation* (2002) 1677–1681.
- [17] X. Hu, R.C. Eberhart, Y. Shi, Particle swarm with extended memory for multiobjective optimization, *Proc. 2003 IEEE Swarm Intell. Symp.* (2003) 193–197.

- 1  
2  
3  
4  
5  
6  
7  
8  
9  
10  
11  
12  
13  
14  
15  
16  
17  
18  
19  
20  
21  
22  
23  
24  
25  
26  
27  
28  
29  
30  
31  
32  
33  
34  
35  
36  
37  
38  
39  
40  
41  
42  
43  
44  
45  
46  
47  
48  
49  
50  
51  
52  
53  
54  
55  
56  
57  
58  
59  
60  
61  
62  
63  
64  
65
- [18] K. E. Parsopoulos, D. K. Tasoulis, M. N. Vrahatis, Multiobjective optimization using parallel vector evaluated particle swarm optimization, Proc. IASTED Int. Conf. Artificial Intell. and Applicat. (2004) 823–828.
  - [19] C. Chow, H. Tsui, Autonomous agent response learning by a multi-species particle swarm optimization, IEEE Congr. Evol. Computation (2004) 778–785.
  - [20] J. Moore, R. Chapman, Application of particle swarm to multiobjective optimization, Department of Computer Science and Software Engineering, Auburn University (1999).
  - [21] J. E. Fieldsend, S. Singh, A multiobjective algorithm based upon particle swarm optimisation, an efficient data structure and turbulence, Proc. 2002 U.K. Workshop Computational Intell. (2002) 37–44.
  - [22] G. Toscano Pulido, C. A. Coello Coello, Using clustering techniques to improve the performance of a particle swarm optimizer, Proc. Genetic and Evol. Computation Conf. (2004) 225–237.
  - [23] D. Srinivasan, T. Hou Seow, Particle swarm inspired evolutionary algorithm (PS-EA) for multiobjective optimization problem, IEEE Congr. Evol. Computation (2003) 2292–2297.
  - [24] S. Mostaghim, J. Teich, Covering pareto-optimal fronts by subswarms in multi-objective particle swarm optimization, IEEE Congr. Evol. Computation (2004) 1404–1411.
  - [25] T. Bartz-Beielstein, P. Limbourg, K. E. Parsopoulos, M. N. Vrahatis, J. Mehnen, K. Schmitt, Particle swarm optimizers for pareto optimization with enhanced archiving techniques, IEEE Congr. Evol. Computation (2003) 1780–1787.
  - [26] X. Li, A non-dominated sorting particle swarm optimizer for multiobjective optimization, in Proc. Genetic and Evol. Computation Conf. (2003) 37–48.
  - [27] S.L. Ho, Y. Shiyou, N. Guangzheng, E.W.C. Lo, H.C. Wong, A particle swarm optimization-based method for multiobjective design optimizations, IEEE Trans. Magn. 41 (2005) 1756–1759.
  - [28] C. R. Raquel, Jr. Prospero, C. Naval, An effective use of crowding distance in multiobjective particle swarm optimization, Proc. Genetic and Evol. Computation Conf. (2005) 257–264.
  - [29] S. Janson, D. Merkle, A new multiobjective particle swarm optimization algorithm using clustering applied to automated docking, Hybrid Metaheuristics, 2nd Int. Workshop (2005) 128–142.
  - [30] A.K. Akella, R.P. Saini, M.P. Sharma, Social, economical and environmental impacts of renewable energy systems, Renew Energ. 34 (2009) 390–396.

[31] International Energy Agency, Benign energy? The environmental implications of renewables, OECD, Paris, 1998.

[32] J.L. Bernal-Agustin, R. Dufo-Lopez, Economical and environmental analysis of grid connected photovoltaic systems in Spain, *Renew Energ.* 31 (2006) 1107–1128.

## List of Figures

Fig. 1. The block diagram of a generalized PVGCS.

Fig. 2. The flowchart of the proposed multiobjective PSO algorithm.

Fig. 3. The Pareto front calculated by the MOPSO1 algorithm.

Fig. 4. The Pareto front calculated by the MOPSO2 algorithm.

Fig. 5. The Pareto front calculated by the MOPSO3 algorithm.

Fig. 6. The Pareto front calculated by the MOPSO4 algorithm.

Fig. 7. The Pareto front calculated by the MOPSO5 algorithm.

Fig. 8. The Pareto front calculated by the MOPSO6 algorithm.

Fig. 9. Comparison of the proposed multiobjective PSO variants for the location of the Pareto front.

Fig. 10. The number of Pareto solutions located by the MOPSO2 variant for several numbers of iterations applied



# Multiobjective Particle Swarm Optimization for the optimal design of photovoltaic grid-connected systems

Aris Kornelakis\*

Technical University of Crete, Department of Electronic and Computer Engineering, University Campus, 73100, Chania, Greece, [akornelakis@gmail.com](mailto:akornelakis@gmail.com)

\*(Corresponding author (A. Kornelakis): E-mail address: [akornelakis@gmail.com](mailto:akornelakis@gmail.com), Tel.: +30-2810-210265)

## Abstract

Particle Swarm Optimization (PSO) is a highly efficient evolutionary optimization algorithm. In this paper a multiobjective optimization algorithm based on PSO applied to the optimal design of photovoltaic grid-connected systems (PVGCSs) is presented. The proposed methodology intends to suggest the optimal number of system devices and the optimal PV module installation details, such that the economic and environmental benefits achieved during the system's operational lifetime period are both maximized. The objective function describing the economic benefit of the proposed optimization process is the lifetime system's total net profit which is calculated according to the method of the Net Present Value (NPV). The second objective function, which corresponds to the environmental benefit, equals to the pollutant gas emissions avoided due to the use of the PVGCS. The optimization's decision variables are the optimal number of the PV modules, the PV modules optimal tilt angle, the optimal placement of the PV modules within the available installation area and the optimal distribution of the PV modules among the DC/AC converters.

**Keywords:** Environmental, economic, multiobjective optimization, particle swarm optimization, photovoltaic systems.

## 1. Introduction

The energy produced by conventional energy sources results in increased Green House Gas (GHG) emissions which, if not drastically reduced, threaten the global climate's stability. The disadvantage of the fossil fuels described above combined with the depletion of their reserves and the rapid growth of the energy demands has led to the exploitation of benign sources of energy, such as Renewable Energy Sources (RES). Those alternative energy production systems, such as Photovoltaic (PV) systems are being supported by many governments on a worldwide basis by means of subsidization of the initial capital invested on them. The photovoltaic grid-connected systems (PVGCSs) are used to supply the local electric grid with the total energy produced by PV

modules. The investment on the installation of PVGCSs is further supported by providing high selling prices of the generated energy from the PV modules, as a significant form of RES applications.

As shown in Fig.1 a PVGCS is comprised of several DC/AC converters while every DC/AC converter's DC input is connected with a PV array which consists of a number of parallel branches of PV modules, while each branch includes several PV modules connected in series.

Fig. 1.

The PVGCS sizing ratio, which is equal to the quotient of the nominal power of the PV array to the nominal power of the total DC/AC converters, is investigated in [1] and [2]. In [1] the optimal sizing ratio is examined through the the TRNSYS simulation tool for several components costs and solar irradiation scenarios. The PVGCS sizing ratio, for which the total system cost is being minimized, is considered to be affected by the solar irradiation conditions at the installation site and the efficiency of the DC/AC converters. In [2] the PVGCS sizing ratio, is investigated in order to minimize the total system cost. Through simulations of the system operation for several locations in Europe and USA it can be concluded that the optimal ratio depends on the DC/AC converter technical characteristics, the orientation of the PV modules and the costs of the system's devices. A methodology for the optimal selection of the PVGCS installation site is presented in [3]. The selection of optimal installation site of the PVGCSs is implemented by decision-support systems incorporating multi-criteria analysis and analytic hierarchy process together with geographical information systems (GIS) technology, taking into account environmental, location, topographic and climate factors. A methodology for the optimal sizing of PVGCSs is proposed in [4]. This methodology reaches the best compromise between technical and economic aspects using a multiobjective optimization approach. The technical impacts are related to the improvement of the voltage stability due to the stochastic PV energy production variation. The economic objectives are related to the PVGCS economic profitability and the cost of the feeder power losses. A method for the optimal design and the economic analysis of PVGCSs is presented in [5]. As shown, the profitability and the design of the PVGCS can be significantly influenced by factors such as the cost of land required for the installation, the subsidization rate and the selling price of the produced energy. The objective of this methodology is the maximization of the system's Net Present Value, while the optimal solutions are explored using a Particle Swarm Optimization (PSO) approach.

However, most of the design methodologies described above do not take into account several important factors, such as the PV modules tilt angle value, the costs of the installation's land and the

construction of the PV modules mounting structures and economic parameters such as the taxation rate of the economic receipts, which can highly influence the design procedure. Moreover, the optimization methodologies are often implemented using conventional programming techniques, which do not guarantee convergence to the optimal solution.

In this paper, a methodology for the design optimization of PVGCSs is presented intending to suggest the optimal values of the PVGCSs installation details such as the number of the PV modules and the DC/AC converters, the PV modules optimal tilt angle, the optimal placement of the PV modules within the installation land and the optimal distribution among the DC/AC converters. The design optimization aims towards the maximization of both the economic and environmental benefits received by the use of PVGCSs. For this reason, a multiobjective technique based on PSO approach, with several variations, has been developed and is presented in this paper. The proposed multiobjective algorithm was applied to the proposed methodology for the concurrent optimization of the objective functions representing the system's benefits subject to maximization. Compared to conventional optimization methods this evolutionary technique of PSO is able of exploring the problem's search space with lower computational complexity, especially in cases of complicated and non-linear objective functions or constraints, like the current problem.

## **2. The proposed methodology and the system models involved**

The proposed methodology's algorithm initiates by the insertion of the case study's inputs containing the technical and economic characteristics of commercially available devices (PV modules and DC/AC converters) along with meteorological data collected for the selected for the installation site and a series of economic parameters. The economic characteristics of the system's devices are the installation and annual maintenance costs per unit. The rest of parameters loaded from the database are the hourly solar irradiation and ambient temperature values during the year, the available area dimensions, the local economy's parameters and finally, parameters used for the computation of the cost of the land and the mounting structures of PV modules. In order to take into account detailed parameters of the installation's structure during the PVGCS multiobjective optimization, several models have been incorporated, describing the distribution of the PV modules among the system's DC/AC converters, their arrangement into the available area and the estimated cost of the PV modules' mounting structures, proposed in [5].

The methodology described in this paper is applicable for PVGCSs and, therefore, it is considered that the total energy produced is injected to the electric grid. The produced energy is calculated on an hourly basis for a one-year time period and the calculated annual PVGCS energy production is assumed to be constant during the system's operational lifetime. The output power of the selected

PV module on day  $d$  ( $1 \leq d \leq 365$ ) and at hour  $t$  ( $1 \leq t \leq 24$ ),  $P_M^d(t, \beta)$  (W), is calculated as described by E. Lorenzo [6]. The PV modules tilt angle,  $\beta$  ( $^\circ$ ), is considered to be constant during the year.

As shown in Fig. 1, each PV array consists of  $N_p$  parallel branches of PV modules ( $N_p \geq 1$ ), while each branch consists of  $N_s$  PV modules connected in series ( $N_s \geq 1$ ). The utilized modeling figures the required number of DC/AC converters for a PVGCS of a total number of PV modules equal to  $N_l$  and distributes the  $N_l$  PV modules to the system's DC/AC converters. The attainable distribution described is implemented by using the values of the minimum and maximum input voltage and the maximum input power for the selected DC/AC converter type, as well as the output voltage and power at the Maximum Power Point (MPP) for the selected PV module type.

The PV modules are arranged within the area in multiple rows facing south, where each row is comprised of multiple lines,  $N_2$ . The arrangement details are calculated according to [5], while the adequate distance between adjacent rows,  $F_y$ , in order to eliminate the mutual shading of the PV modules during each hour of the year is calculated as described in [7]. The dimensions of the useful area finally occupied by PV modules,  $D_1$  (m) and  $D_2$  (m), are also calculated as proposed in [5].

In order to incorporate the cost of the PV module mounting structures in the optimal sizing procedure, a generalized model has been used [5]. The mounting structures are manufactured using metallic spars. The calculation of the corresponding cost is based on the calculation of the total raw materials required. The specific model's outputs are the total length of the metallic spars,  $B$  (m), required for the installation of the entire PVGCS and the total volume of the concrete bases,  $B_B$  ( $\text{m}^3$ ). The total cost of the mounting structures,  $C_B$  (€), is equal to the sum of the metallic spars and the concrete foundation bases costs:

$$C_B = B \cdot c_S + B_B \cdot c_B \quad (1)$$

where  $c_S$  (€/m) is the cost per length of the metallic spars and  $c_B$  (€/m<sup>3</sup>) is the cost per volume of the concrete bases. The value of  $c_S$  typically depends on the required thickness of the construction material and is specified by the designer.

After inserting the inputs of the current methodology, the PV energy production data is computed as described above. Afterwards, a multiobjective PSO algorithm is applied for the production of several resulting PVGCSs using appropriate multiobjective methods and the system models incorporated for the estimation of the objective functions (net profits and environmental benefits) of each new solution.

### 3. The proposed multiobjective PSO algorithm

The PSO algorithm is a stochastic optimization technique based on the evolution of a population of solutions. It was proposed by Eberhart and Kennedy [8] as an alternative method to the Genetic Algorithms (GAs) inspired by the social behavior of the bird swarms. The basic PSO algorithm for the calculation of the next position of the particle is:

$$v_{i+1}(j) = v_i(j) + c_1 \cdot r_{1,i}(j) \cdot [pbest(j) - x_i(j)] + c_2 \cdot r_{2,i}(j) \cdot [gbest(j) - x_i(j)] \quad (2)$$

$$x_{i+1}(j) = v_{i+1}(j) + x_i(j) \quad (3)$$

where  $i$  is the number of iteration,  $j$  is the variable of the optimization vector,  $x_i(j)$  is the value of the variable  $j$  at the iteration  $i$ ,  $v_i(j)$  is the velocity of the variable  $j$  at the iteration  $i$ ,  $c_1$  and  $c_2$  are constant variables usually set equal to 2,  $r_{1,i}$  and  $r_{2,i}$  are random variables in the range  $[0,1]$ ,  $pbest(j)$  is the value of the variable  $j$  of the best solution of the specific particle up to the iteration  $i$  and  $gbest(j)$  is the value of the variable  $j$  of the best solution located by the swarm up to the iteration  $i$ . Eberhart et al. [9] proposed the limiting of the speed of each particle to a range  $[-v_{max}, v_{max}]$  in order to reduce the possibility of particle flying out of the problem's space. Shi and Eberhart [11] noted that the lack of the velocity memory ( $v_i(j)$  in (2)) the swarm results in cramping at the global best solution found within the initial swarm. In contrary, the velocity memory pushes the swarm to behave oppositely, providing a global search. In order to balance between exploration and exploitation a modified PSO algorithm, incorporating an inertia weight,  $w$ , was introduced thus:

$$v_{i+1}(j) = w \cdot v_i(j) + c_1 \cdot r_{1,i}(j) \cdot [pbest(j) - x_i(j)] + c_2 \cdot r_{2,i}(j) \cdot [gbest(j) - x_i(j)] \quad (4)$$

In [11] it is proposed that the value of  $w$  is initially set to 0.9 reducing linearly to 0.4 during a number of optimization iterations. Constriction is a substitutional way of controlling the behavior of particles. Instead of applying inertia weight to the velocity memory, in [12] a method known as Constriction PSO (CPSO), incorporating a constriction factor,  $\chi$ , to the new velocity is presented:

$$v_{i+1}(j) = \chi \cdot \{v_i(j) + c_1 \cdot r_{1,i}(j) \cdot [pbest(j) - x_i(j)] + c_2 \cdot r_{2,i}(j) \cdot [gbest(j) - x_i(j)]\} \quad (5)$$

Where  $\chi$  is the constriction factor calculated is following:

$$\chi = \frac{2}{\left|2 - c - \sqrt{c^2 - 4 \cdot c}\right|} \quad (6)$$

and  $c$  is equal to  $c = c_1 + c_2, c > 4$ .

When optimizing two or more competitive objective functions together, the arising problem is the definition of a model satisfying the conflicting objective functions. This problem is called multiobjective optimization. In multiobjective optimization, the solution is chosen from a set of solutions called Pareto front [13]. Given two vectors  $y_1^*$  and  $y_2^*$  where  $y_1^* = [y_{1,1}, y_{1,2} \dots y_{1,k}]$ ,  $y_2^* = [y_{2,1}, y_{2,2} \dots y_{2,k}]$ ,  $k$  is the number of the problem's objective functions and  $y_{1,i}, y_{2,i}$  are the values of the  $i$ -th objective function for the two vectors, respectively. If each objective function is subject to maximization and  $y_{1,i} \geq y_{2,i}, \forall i \in [1, k]$  then it is considered that  $y_1^*$  dominates  $y_2^*$  ( $y_1^* \succ y_2^*$ ). A vector  $y_1^*$  is called Pareto optimal if it is not dominated by any other feasible solution. Several methods have been proposed for the multiobjective optimization using PSO that are, generally, based on the concept of Pareto dominance.

In [14] an algorithm that sums the problem's objective functions in one is presented in three different ways. The first approach includes a linear combination with coefficients determined during the algorithm's execution, the second approach a dynamic combination function with gradually altering weights and, finally, the third approach includes a combination function with suddenly altering weights (bang bang aggregation approach). The sharing of the population members in equally sized sub-populations is proposed in [15]. In each subpopulation a linear combination of the objective functions is used with different weights and evolves following the best solution emerging between its members. In [16] and [17] an algorithm which optimizes each objective function separately according to the ranking of their importance, is presented. In [18] the simultaneous optimization of the objective functions is applied using a corresponding number of swarms that exchange information relative with the best solutions located. This algorithm is called VEPSO, inspired from a Genetic Algorithms (GAs) approach. In [19] the multi-species PSO is proposed where the multiobjective optimization problem is treated as a problem of single objective functions, each one corresponding to a sub-swarm. Like in the previous approach, the populations communicate by sending the characteristics of their best particles. A scheme based on Pareto dominance is presented in [20]. In this methodology the combination of the searching process and the personal best solutions of the particles (pbest vectors) is of high importance. The personal best solution of each particle is considered to be randomly chosen from a list with the total non-dominated solutions located by the specific particle. In [21] an approach is presented where all the non-dominated solution located are stored in a structure from which the nearest solution is chosen as

the global best solution for the application of the PSO algorithm. Moreover, a “mutation” operator is used to affect PSO’s velocity vector. In [22] the dominance theory is used to direct the particles, using clustering techniques for the division of the subpopulation aiming towards the dispersion of the particles in the search space. The “Particle Swarm Inspired Evolutionary Algorithm” (PS-EA) is presented in [23]. This method is a hybrid PSO and evolutionary algorithm based on the competition between the operators of the two methods. The proposed algorithm includes mutation and selection operators that utilize the Pareto ranking. In [24] the coveringMOPSO (cvMOPSO) algorithm is presented. The operation of the cvMOPSO is divided in two phases. Initially, the Pareto front is being reached approximately and then, the population is being distributed around the solutions of the existing front. The investigators of this method claim that this is a way of better exploration of the dominant solutions. In [25] the application of PSO is proposed together with the use of several methods for the insertion or the deletion of Pareto solutions. The methods presented are related to the diversity of the solutions of the existing Pareto front. The method proposed in [26] involves mechanisms of combination of the whole population’s members together with their personal best solutions into a united population from which only the non-dominated solutions are chosen for the next swarm. Moreover, the personal best solution of each particle is selected randomly from a list with all the non-dominated solutions located by the specific particle. Several modifications of the PSO algorithm are proposed in [27]. The dependence between the random factors ( $r_{1,i}$  and  $r_{2,i}$ ) and the application of a weighting factor to the second and the third component of the PSO equation are among the changes proposed. Also, the storing of all the non-dominated solutions found by each particle is proposed. The deletion of Pareto solutions and the choice of the global optimal solution for the particles according to a probability density function are presented in [28]. The Pareto front is being ranked by taking into account the density of members in each solution’s area and the global optimal solution is chosen randomly from its top. In [29] the clustMPSO algorithm is presented. The specific approach combines clustering techniques with PSO methods and divides the population to subsets. The final Pareto front is the join of the separate fronts emerging in each sub-swarm. The specific algorithm was applied to the multiobjective optimization of biochemistry problem.

In this paper, an alternative PSO algorithm is proposed for the optimization of multiobjective problems. The proposed algorithm starts with the random initialization of the initial population. The repairing algorithm is applied for the correction of the initial particles that violate the problem’s constraints. The repairing algorithm developed modifies the values of the decision variables of those particles such that all of constraints are fully satisfied. The constraints refer to the feasibility of the arrangement of the PV modules into the available land area, the distribution of the PV modules among the system’s DC/AC Converters and the values range of each decision variable and are examined through appropriate simulation algorithms. The feasible swarm is then evaluated by each

objective function separately and the corresponding values are stored, while a global best solution  $gbest_k$  arises for each one of the  $k$  objective functions. Afterwards, the  $pbest_k$  vectors are being initialized for every single objective function. The algorithm's initialization process ends with the creation of the initial Pareto set with the non-dominated solutions inside the initial swarm. When the computations described above are completed, the iterative procedure starts with the application, initially, of the multiobjective PSO algorithm which its velocity equation is a variation of either the simple PSO method (2) or the inertia PSO (4) or the CPSO method (5). The resulting variants are named MOPSO1, MOPSO2 and MOPSO3, respectively, and are described by the following equations:

$$v_{i+1}(j) = v_i(j) + c_1 \cdot r_{1,i}(j) \cdot \frac{\sum_k [pbest_k(j) - x_i(j)]}{k} + c_2 \cdot r_{2,i}(j) \cdot \frac{\sum_k [gbest_k(j) - x_i(j)]}{k} \quad (7)$$

$$v_{i+1}(j) = w \cdot v_i(j) + c_1 \cdot r_{1,i}(j) \cdot \frac{\sum_k [pbest_k(j) - x_i(j)]}{k} + c_2 \cdot r_{2,i}(j) \cdot \frac{\sum_k [gbest_k(j) - x_i(j)]}{k} \quad (8)$$

$$v_{i+1}(j) = \chi \cdot \left\{ v_i(j) + c_1 \cdot r_{1,i}(j) \cdot \frac{\sum_k [pbest_k(j) - x_i(j)]}{k} + c_2 \cdot r_{2,i}(j) \cdot \frac{\sum_k [gbest_k(j) - x_i(j)]}{k} \right\} \quad (9)$$

The new population is, then, formed according to (3). Three other variations of the velocity equation of the proposed multiobjective algorithm are, also, presented in this paper. The basic difference from the variants described above lies on the formation of the third component of the PSO algorithm (related with the global optimal solutions). In particular, in these variants, the global optimal solution's values are being replaced by the values  $gbest_r(j)$  of a randomly chosen member of the existing Pareto set, up to the instant iteration. In these variants, the velocity equations could also be variations of either the simple PSO method (2) or the inertia PSO (4) or the CPSO method (5). The resulting variants are named MOPSO4, MOPSO5 and MOPSO6, respectively, and are described by the following equations:

$$v_{i+1}(j) = v_i(j) + c_1 \cdot r_{1,i}(j) \cdot \frac{\sum_k [pbest_k(j) - x_i(j)]}{k} + c_2 \cdot r_{2,i}(j) \cdot [gbest_r(j) - x_i(j)] \quad (10)$$

$$v_{i+1}(j) = w \cdot v_i(j) + c_1 \cdot r_{1,i}(j) \cdot \frac{\sum_k [pbest_k(j) - x_i(j)]}{k} + c_2 \cdot r_{2,i}(j) \cdot [gbest_r(j) - x_i(j)] \quad (11)$$



$$v_{i+1}(j) = \chi \cdot \left\{ v_i(j) + c_1 \cdot r_{1,i}(j) \cdot \frac{\sum_k [pbest_k(j) - x_i(j)]}{k} + c_2 \cdot r_{2,i}(j) \cdot [gbest_r(j) - x_i(j)] \right\} \quad (12)$$

After the application of a variant of the multiobjective PSO algorithm, the repairing algorithm is applied and every particle is evaluated according to each objective function, separately, while the  $pbest_k$  vectors are being updated. At the end of each iteration, the Pareto set is being updated by adding new dominant solutions or removing previous Pareto solutions that are dominated by newly generated members of the current population. The population's size remains constant during the algorithm's execution, while the size of the Pareto set changes dynamically. After a specific predefined number of iterations, the proposed multiobjective algorithm gives the located Pareto front. In Fig. 2 the flowchart of the proposed multiobjective PSO algorithm is shown.

#### 4. The objective functions of the multiobjective maximization process

In the proposed method, the decision variables used during the optimization procedure are  $N_1$ ,  $N_2$  and  $\beta$ . The optimal total number of DC/AC converters and the distribution of the PV modules among them, the dimensions of the required area and the optimal placement of the PV modules into the available area are calculated using the optimal values of the three decision variables. The multiobjective problem involves the maximization of two objective functions, representing the economic and the environmental benefits arising due to the installation of the PVGCS.

Fig. 2.

The first objective function subject to maximization is the PVGCS total net profit function,  $f_1(\mathbf{x})$  (€), and is calculated according to the widely used methodology of NPV:

$$f_1(\mathbf{x}) = P_E(\mathbf{x}) - C_c(\mathbf{x}) - C_m(\mathbf{x}) \quad (13)$$

where  $\mathbf{x}$  represents the vector of the decision variables,  $P_E(\mathbf{x})$  (€) represents the total profits achieved during the system's lifetime period,  $C_c(\mathbf{x})$  (€) is the total capital and  $C_m(\mathbf{x})$  (€) the total maintenance cost. The total net profit achieved during the PVGCS operational lifetime period depends on the amount of energy generated by the system's PV modules and on the price that the energy produced by the PVGCS is sold to the electric grid and not on the price that the electric grid customers purchase the electric energy from the electric grid operator in order to fulfil their energy requirements, or the corresponding load profile.

The total capital cost,  $C_c(\mathbf{x})$ , is calculated as follows:

$$C_c(\mathbf{x}) = \left(1 - \frac{s}{100}\right) \cdot (N_I \cdot C_{PV} + N_{dc} \cdot C_{INV} + C_L + C_B) \quad (14)$$

where  $s$  (%) is the subsidization rate,  $C_{PV}$  (€) and  $C_{INV}$  (€) are the capital costs of each PV module and DC/AC converter, respectively,  $N_{dc}$  is the number of the DC/AC converters required for the installation of  $N_I$  PV modules, calculated according to [5],  $C_L$  (€) is the cost of the installation area and  $C_B$  (€) is the cost of the mounting structures (1).

The cost of the required installation area,  $C_L$ , is calculated as follows:

$$C_L = D_1 \cdot D_2 \cdot c_l \quad (15)$$

where  $c_l$  is the cost of the land per unit (€/m<sup>2</sup>).

The present value of the maintenance cost,  $C_m(\mathbf{x})$ , during the PVGCS operational lifetime period is calculated using the following equation:

$$C_m(\mathbf{x}) = (N_I \cdot M_{PV} + N_{dc} \cdot M_{INV}) \cdot (1 + g) \cdot \left[ \frac{1 - \left(\frac{1+g}{1+i}\right)^n}{i - g} \right] + R_{TC} \quad (16)$$

where  $M_{PV}$  and  $M_{INV}$  (€/year) are the annual maintenance costs per unit of the PV modules and the DC/AC converters, respectively,  $g$  (%) is the annual inflation rate,  $i$  (%) is the nominal annual discount rate and  $R_{TC}$  (€) is the present value of the total cost of repairing the PVGCS DC/AC converters:

$$R_{TC} = N_{dc} \cdot R_{cost} \cdot \left[ \sum_{\forall j=k^*} \frac{(1+g)^j}{(1+i)^j} \right] \quad (17)$$

where  $k^*$  are the year numbers that the DC/AC converters must be repaired and  $R_{cost}$  (€) is the cost of each DC/AC converter repairing.

The  $k^*$  values depend on the number of repairs during the PVGCS lifetime,  $N_r$ , which is calculated as follows:

$$N_r = \frac{n \cdot 24 \cdot 365}{MTBF} \quad (18)$$

where  $MTBF$  (h) is the mean time between failures of the DC/AC converters.

The present value of the total profits achieved from selling the PV generated energy to the electric grid,  $P_E(\mathbf{x})$  (€), is calculated as follows:

$$P_E(\mathbf{x}) = \left(1 - \frac{tax}{100}\right) \cdot C_o \cdot N_1 \cdot E_{tot} \cdot \frac{\left(1 - \left(\frac{1}{1+i}\right)^n\right)}{i} \quad (19)$$

$$E_{tot} = n_{INV} \cdot n_{MPPT} \cdot \sum_{d=1}^{365} \sum_{i=1}^{24} \frac{P_M^d(t, \beta)}{1000 \text{ W/kW}} \cdot \Delta t \quad (20)$$

where  $tax$  (%) represents the taxation rate of the profits,  $C_o$  (€/kWh) is the energy selling price,  $E_{tot}$  (kWh) is the total annual energy generated by each PV module,  $\Delta t$  is the simulation time step, set to  $\Delta t = 1$  hour,  $n_{INV}$  is the DC/AC converter's efficiency and  $n_{MPPT}$  is a conversion factor indicating the MPPT accuracy of the DC/AC converter.

The second objective function subject to maximization is the PVGCS total environmental benefit function,  $f_2(\mathbf{x})$  (kg CO<sub>2</sub>), describing the total CO<sub>2</sub> emissions avoided due to the use of the PVGCS according to the method of Life Cycle Assessment (LCA) [30]:

$$f_2(\mathbf{x}) = E_{conv}(\mathbf{x}) - E_{PVGCS}(\mathbf{x}) - E_{inst}(\mathbf{x}) \quad (21)$$

where  $E_{conv}(\mathbf{x})$  describes the CO<sub>2</sub> emissions released by a conventional energy generation system for the production of the total energy estimated to be generated by the PVGCS,  $E_{PVGCS}(\mathbf{x})$  describes the CO<sub>2</sub> emissions released by the PVGCS and  $E_{inst}(\mathbf{x})$  describes the CO<sub>2</sub> emissions released during the production and installation of the structure of the PVGCS. The CO<sub>2</sub> emissions released by a conventional energy generation system,  $E_{conv}(\mathbf{x})$  (kg CO<sub>2</sub>), are calculated as follows:

$$E_{conv}(\mathbf{x}) = N_1 \cdot E_{tot} \cdot f_{conv} \quad (22)$$

where  $f_{conv}$  (kg CO<sub>2</sub> per kWh) is a factor indicating the estimated CO<sub>2</sub> emissions released by a conventional energy source system per energy unit. In Table 1, the value of this factor for several

conventional sources is shown [31]. The CO<sub>2</sub> emissions released by a PV system,  $E_{PVGCS}(\mathbf{x})$  (kg CO<sub>2</sub>), are calculated as follows:

$$E_{PVGCS}(\mathbf{x}) = N_1 \cdot E_{tot} \cdot f_{PV} \quad (23)$$

where  $f_{PV}$  (kg CO<sub>2</sub> per kWh) is a factor indicating the estimated CO<sub>2</sub> emissions released by a PV system per energy unit. The corresponding value is equal to 0.098 kg/kWh according to [31]. The CO<sub>2</sub> emissions released during the production and installation of the devices of a PV system,  $E_{inst}(\mathbf{x})$  (kg CO<sub>2</sub>), are calculated as follows:

$$E_{inst}(\mathbf{x}) = P_{Peak} \cdot f_{prod} \quad (24)$$

where  $f_{prod}$  (kg CO<sub>2</sub> per kWp) is a factor indicating the estimated CO<sub>2</sub> emissions released during the production and installation of a PV system per installed power unit and  $P_{Peak}$  (kWp) is the PVGCS installed power equal to :

$$P_{Peak} = P_{PV} \cdot N_1 / 1000 \quad (25)$$

where  $P_{PV}$  (W) is the nominal power of the selected PV module, according to the specifications of its manufacturer. The value of  $f_{prod}$  can be set equal to 1392.1 kg CO<sub>2</sub> per kWp according to [32].

**Table 1**

Carbon	Oil	Natural Gas	Diesel
955	818	430	772

The CO<sub>2</sub> emissions per energy unit (kg/kWh) for several conventional energy sources

## 5. Results

The methodology described in the previous sections has been applied for the optimal design of PVGCSs joint to the electric network of the island of Crete. The daily global solar irradiation on horizontal plane and the hourly mean ambient temperature data that were recorded at the area of the Technical University of Crete (latitude: 35°). According to the current local market prices, the cost of the metallic spars,  $c_s$ , was set equal to 33€/m and the cost of the concrete foundation bases,  $c_B$ , was set equal to 230€/m<sup>3</sup>. The annual inflation rate,  $g$ , was set equal to 4% and the nominal annual

discount rate,  $i$ , was set equal to 8%. According to the Greek legislation, the selling price of the energy produced by the PVGCS has been set to  $C_o = 0.50\text{€} / kWh$  for systems with total installed PV modules power up to 100kW and to  $C_o = 0.45\text{€} / kWh$  for systems with higher installed power. Also, the PVGCS operational lifetime period has been set equal to 25 years. The main energy source for the island of Crete is considered to be the oil, with a corresponding value of CO<sub>2</sub> emissions per energy unit equal to  $f_{conv} = 0.818$  kg CO<sub>2</sub> per kWh. In Table 2, the optimal sizing results according to the objective functions of the environmental and the economic benefits, separately, are shown. The upper limits of the decision variables  $N_1$  and  $N_2$  were set equal to  $N_1^U = 5\ 000$  and  $N_2^U = 100$  while the dimensions of the available land are set equal to  $DIM_1 = 10m$  (southern side) and  $DIM_2 = 100m$  (western side). The results shown, were generated for subsidization rate equal to  $s = 0\%$ , taxation rate equal to  $tax = 0\%$  and cost of the installation area equal to  $c_l = 0\text{€} / m^2$ . The NPV ( $f_1$ ) is presented together with the total cash inflows, the total expenses, the discounted payback time ( $n^*$ ) [5] and the Internal Rate of Return (IRR) [5] of the proposed PVGCS.

**Table 2**

	Optimal PVGCS according to environmental benefit	Optimal PVGCS according to economic benefit
$N_1$	684	576
$N_2$	100	12
$\beta$	27°	8°
$N_{dc}$	19	16
$f_1(NPV)$	288 270.77€	544 565.07€
$C_c(x)$	747 597.27€	396 433.79€
$C_m(x)$	69 512.96€	65 982.35€
$P_E(x)$	1 105 381€	1 006 981.21€
$n^*$	12.3 years	5.7 years
<b>IRR</b>	13%	22%
$f_2$	3 980 155 kg CO <sub>2</sub>	3 259 665 kg CO <sub>2</sub>
$E_{conv}(x) - E_{PVGCS}(x)$	4 142 029 kg CO <sub>2</sub>	3 395 979 kg CO <sub>2</sub>
$E_{inst}(x)$	161 873 kg CO <sub>2</sub>	136 314 kg CO <sub>2</sub>

The PVGCS optimal structure and analysis according to either environmental or economic benefits in case that  $s = 0\%$ ,  $c_1 = 0 \text{ €/m}^2$ ,  $\text{tax} = 0\%$ ,  $DIM_1 = 10\text{m}$ ,  $DIM_2 = 100\text{m}$ .

As shown in Table 2, the single-objective design optimization of the PVGCS according to environmental and economic benefits, separately, results in two totally different system structures. Also, the values of the objective functions for the two resulting systems are very different (e.g. the NPV of the optimal system according to the economic benefits is about two times higher than the NPV of the optimal system according to the environmental benefits). It is also profound that there are many differences between the system parameters of the two resulting cases described above, which is expected, since the single-objective environmental optimization actually is identical to the maximization of the system's energy production, while the economic optimization refers to the total net profit maximization, including several costs, which often results in a totally different system structure. Therefore, it can be concluded that the two objective functions of the proposed PVGCS

methodology are mutually competitive and the multiobjective optimization procedure is of high importance.

The proposed multiobjective PSO variants were applied for the simultaneous multiobjective optimization of the two objective functions, describing the economic and environmental benefits of the PVGCS under design. The results shown below refer to PVGCSs with economic and available land parameters equal to those reported above, for the production of the results presented in Table 2. In Figs. 3 – 8 the Pareto front calculated by the application of the MOPSO1, MOPSO2, MOPSO3, MOPSO4, MOPSO5 & MOPSO6 variants are shown. More specifically, following figures depict the Pareto optimal PVGCS solutions, relatively to the respective economic and environmental benefits of each solution. The proposed algorithms were applied for 2 000 iterations. Through sufficient number of trials, it was observed that after this number of iterations, the Pareto front located remains unchangeable.

Fig. 3.

Fig. 4.

Fig. 5.

Fig. 6.

Fig. 7.

Fig. 8.

It can be observed that the MOPSO4, MOPSO5 & MOPSO6 variants, based on the usage of randomly chosen solutions of the existing Pareto sets, fail to explore adequately the Pareto area close to the optimal results according to economic benefits (higher values of  $f_1$ ), while the MOPSO5 variant with the usage of an inertia weight works slightly better. In contrary, the MOPSO1, MOPSO2 & MOPSO3 variants have a better performance, with the MOPSO2 variant, incorporating the usage of an inertia weight, outbalance the two other methods. In Fig. 9, the six variant schemes of the proposed multiobjective PSO technique are compared together for the multiobjective optimal design of the PVGCS described above.

Fig. 9.

As shown in Fig. 9, all of the proposed multiobjective PSO variants locate a satisfactory number of Pareto solutions (usually more than 20), while some of them perform slightly better, as mentioned above. In Fig. 10 the number of Pareto solutions located by the MOPSO2 variant is shown for several numbers of iterations applied. The runtime of the proposed algorithms for the execution of

2 000 iterations does not exceed the total time of two minutes. The PVGCS multiobjective optimal sizing algorithm using PSO was developed using the C++ language and the CPU times referred were gathered using a PC with a 3.0GHz CPU.

Fig. 10.

## 6. Conclusions

The energy crisis due to the increasing energy demands and the pollution caused by conventional energy generating sources have resulted to the wide use of PVGCSs for providing the electric grid with the PV generated energy. In many countries private investors are encouraged to invest on PVGCSs by means of subsidization of the installation's cost. A methodology for the optimal sizing and analysis of the economic and environmental profitability of PVGCSs has been presented in this paper. The purpose of the proposed methodology is to suggest the optimal design parameters of a PVGCS such that the economic and environmental are both maximized. Several variants of a multiobjective algorithm based on PSO have been developed for the optimization of multiple objective functions. The proposed multiobjective PSO variants have been applied for the multiobjective design optimization of PVGCSs. It was observed that the MOPSO2 variant, based on the usage of the mean values of the personal and global best solutions for each objective function and the application of an inertia weight to the PSO velocity equation, outperformed the rest of the proposed multiobjective PSO variations.

According to the optimization results, the multiobjective optimization of the proposed methodology is meaningful, while the proposed multiobjective PSO variants achieve the exploration of the Pareto front and the location of a sufficient number of Pareto optimal solutions, providing multiple alternative PVGCS structures in a very short time.

## References

- [1] J.D. Mondol, Y.G. Yohanis, B. Norton, Optimal sizing of array and converter for grid-connected photovoltaic systems, *Sol. Energy* 80 (2006) 1517–1539.
- [2] K. Peippo, P.D. Lund, Optimal sizing of grid-connected PV-systems for different climates and array orientations: a simulation study, *Sol. Energy Mater. Sol. Cells* 35 (1994) 445-451.
- [3] J.A. Carrion, A.E. Estrella, F.A. Dols, M.Z. Toro, M. Rodríguez, A.R. Ridaio, Environmental decision-support systems for evaluating the carrying capacity of land areas: Optimal site



- selection for grid-connected photovoltaic power plants, *Renew. Sust. Energ. Rev.* 12 (2008) 2358-2380.
- [4] A. Medina, J.C. Hernandez, F. Jurado, Optimal placement and sizing procedure for PV systems on radial distribution feeders, *IEEE Int. Conf. Power Syst. Technol.* (2006).
- [5] A. Kornelakis, Y. Marinakis, Contribution for optimal sizing of grid-connected PV-systems using PSO, *Renew. Energ.* 35 (2010) 2143-2398.
- [6] E. Lorenzo, *Solar Electricity: Engineering of photovoltaic Systems*, 1st ed., Progensa, Sevilla, 1994.
- [7] J. Appelbaum, J. Bany, Shadow Effect of Adjacent Solar Collectors in Large Scale Systems, *Solar Energy* 23 (1979) 497-507.
- [8] J. Kennedy, R.C. Eberhart, Particle swarm optimization, *Proc. IEEE Int. Conf. Neural Networks* (1995) 1942–1948.
- [9] R.C. Eberhart, P. Simpson, R. Dobbins, *Computational intelligence PC tools*, CA: AP Professional, San Diego, 1996.
- [10] Y. Shi, R.C Eberhart, A modified particle swarm optimizer, *Proc. IEEE Int. Conf. Evol. Computation* (1998) 69–73.
- [11] R.C. Eberhart, Y. Shi, Comparing Inertia Weights and Constriction Factors in Particle Swarm Optimization, *Proc. IEEE Congr. Evol. Computation* (2000) 84–88.
- [12] M. Clerc, J. Kennedy, The particle swarm: explosion, stability and convergence in a multi-dimensional complex space, *IEEE Trans. Evol. Comput.* 6 (2002) 58–73.
- [13] C.A. Coello Coello, G.B. Lamont, D.A.V. Veldhuizen, *Evolutionary Algorithms for Solving Multi-Objective Problems*, 2nd ed., Springer, New York, 2007.
- [14] K.E. Parsopoulos, M.N. Vrahatis, Particle swarm optimization method in multiobjective problems, *Proc. 2002 ACM Symp. Appl. Computing* (2002) 603–607.
- [15] U. Baumgartner, Ch. Magele, W. Renhart, Pareto optimality and particle swarm optimization, *IEEE Trans. Magn.* 40 (2004) 1172–1175.
- [16] X. Hu, R.C. Eberhart, Multiobjective optimization using dynamic neighborhood particle swarm optimization, *IEEE Congr. Evol. Computation* (2002) 1677–1681.
- [17] X. Hu, R.C. Eberhart, Y. Shi, Particle swarm with extended memory for multiobjective optimization, *Proc. 2003 IEEE Swarm Intell. Symp.* (2003) 193–197.

- [18] K. E. Parsopoulos, D. K. Tasoulis, M. N. Vrahatis, Multiobjective optimization using parallel vector evaluated particle swarm optimization, *Proc. IASTED Int. Conf. Artificial Intell. and Applicat.* (2004) 823–828.
- [19] C. Chow, H. Tsui, Autonomous agent response learning by a multi-species particle swarm optimization, *IEEE Congr. Evol. Computation* (2004) 778–785.
- [20] J. Moore, R. Chapman, Application of particle swarm to multiobjective optimization, Department of Computer Science and Software Engineering, Auburn University (1999).
- [21] J. E. Fieldsend, S. Singh, A multiobjective algorithm based upon particle swarm optimisation, an efficient data structure and turbulence, *Proc. 2002 U.K. Workshop Computational Intell.* (2002) 37–44.
- [22] G. Toscano Pulido, C. A. Coello Coello, Using clustering techniques to improve the performance of a particle swarm optimizer, *Proc. Genetic and Evol. Computation Conf.* (2004) 225–237.
- [23] D. Srinivasan, T. Hou Seow, Particle swarm inspired evolutionary algorithm (PS-EA) for multiobjective optimization problem, *IEEE Congr. Evol. Computation* (2003) 2292–2297.
- [24] S. Mostaghim, J. Teich, Covering pareto-optimal fronts by subswarms in multi-objective particle swarm optimization, *IEEE Congr. Evol. Computation* (2004) 1404–1411.
- [25] T. Bartz-Beielstein, P. Limbourg, K. E. Parsopoulos, M. N. Vrahatis, J. Mehnen, K. Schmitt, Particle swarm optimizers for pareto optimization with enhanced archiving techniques, *IEEE Congr. Evol. Computation* (2003) 1780–1787.
- [26] X. Li, A non-dominated sorting particle swarm optimizer for multiobjective optimization, in *Proc. Genetic and Evol. Computation Conf.* (2003) 37–48.
- [27] S.L. Ho, Y. Shiyou, N. Guangzheng, E.W.C. Lo, H.C. Wong, A particle swarm optimization-based method for multiobjective design optimizations, *IEEE Trans. Magn.* 41 (2005) 1756–1759.
- [28] C. R. Raquel, Jr. Prospero, C. Naval, An effective use of crowding distance in multiobjective particle swarm optimization, *Proc. Genetic and Evol. Computation Conf.* (2005) 257–264.
- [29] S. Janson, D. Merkle, A new multiobjective particle swarm optimization algorithm using clustering applied to automated docking, *Hybrid Metaheuristics, 2nd Int. Workshop* (2005) 128–142.
- [30] A.K. Akella, R.P. Saini, M.P. Sharma, Social, economical and environmental impacts of renewable energy systems, *Renew Energ.* 34 (2009) 390–396.

- [31] International Energy Agency, *Benign energy? The environmental implications of renewables*, OECD, Paris, 1998.
- [32] J.L. Bernal-Agustin, R. Dufo-Lopez, *Economical and environmental analysis of grid connected photovoltaic systems in Spain*, *Renew Energ.* 31 (2006) 1107–1128.

### **List of Figures**

Fig. 1. The block diagram of a generalized PVGCS.

Fig. 2. The flowchart of the proposed multiobjective PSO algorithm.

Fig. 3. The Pareto front calculated by the MOPSO1 algorithm.

Fig. 4. The Pareto front calculated by the MOPSO2 algorithm.

Fig. 5. The Pareto front calculated by the MOPSO3 algorithm.

Fig. 6. The Pareto front calculated by the MOPSO4 algorithm.

Fig. 7. The Pareto front calculated by the MOPSO5 algorithm.

Fig. 8. The Pareto front calculated by the MOPSO6 algorithm.

Fig. 9. Comparison of the proposed multiobjective PSO variants for the location of the Pareto front.

Fig. 10. The number of Pareto solutions located by the MOPSO2 variant for several numbers of iterations applied

Figure 1

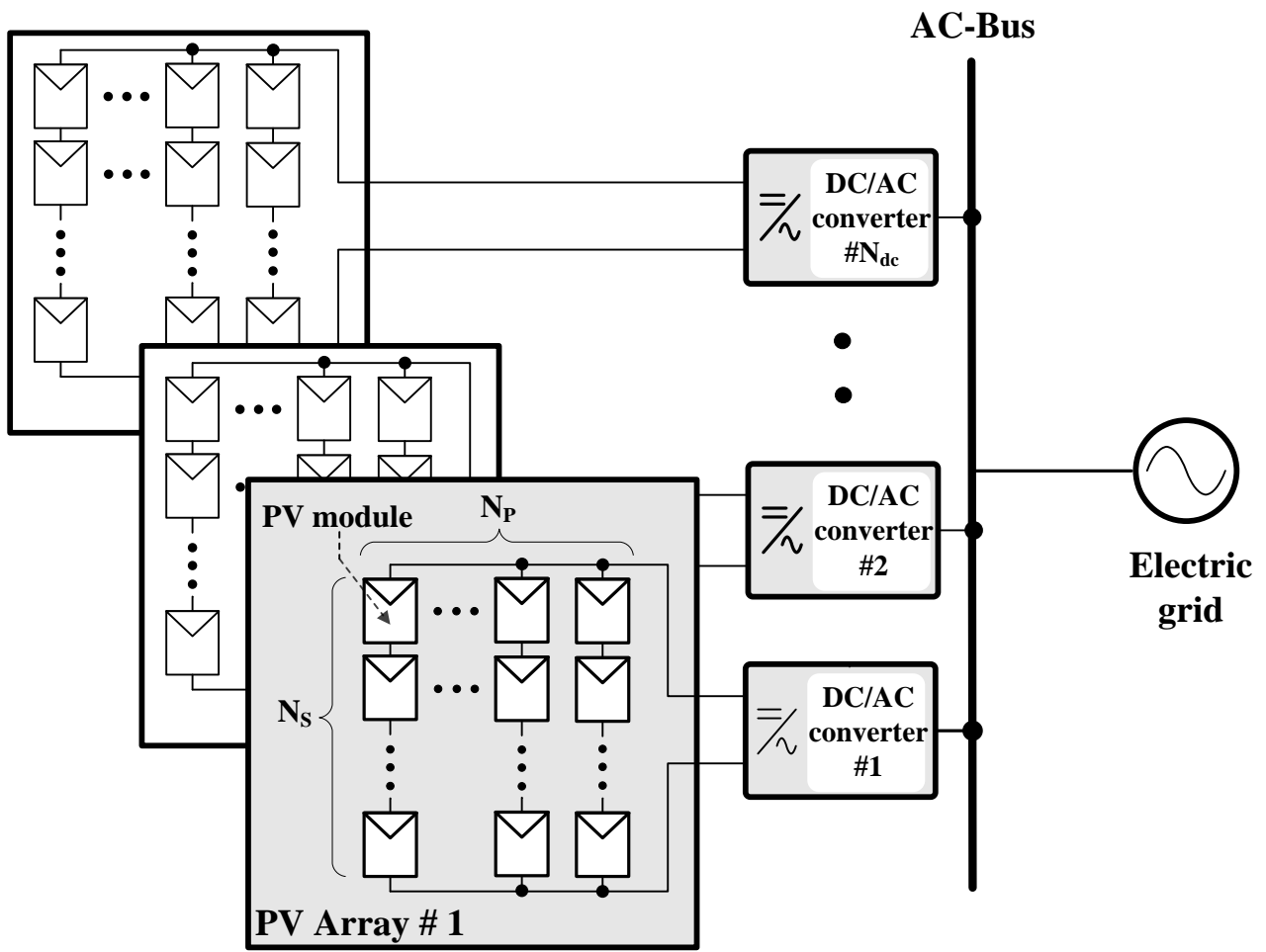

Figure 2

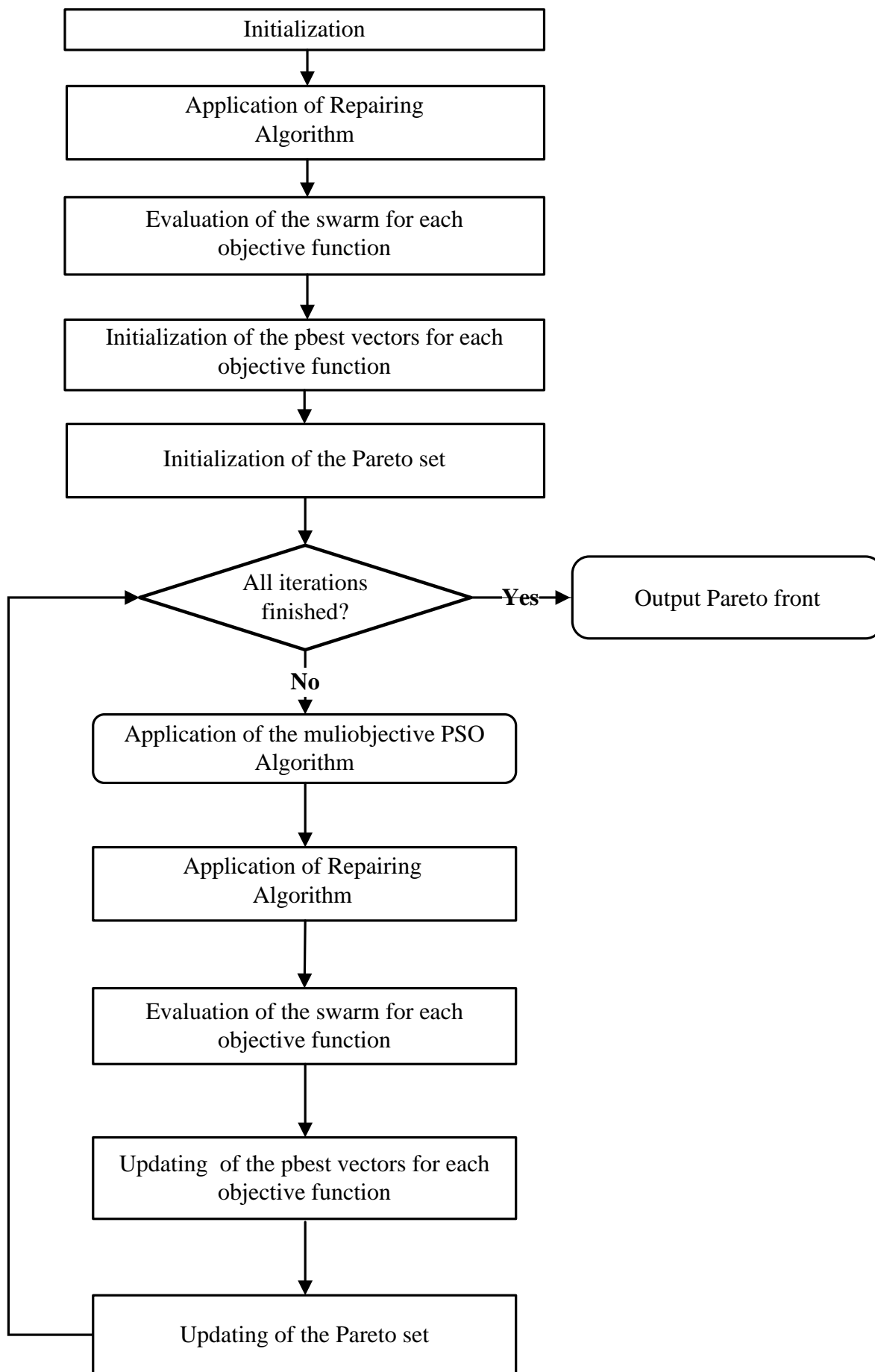

Figure 3

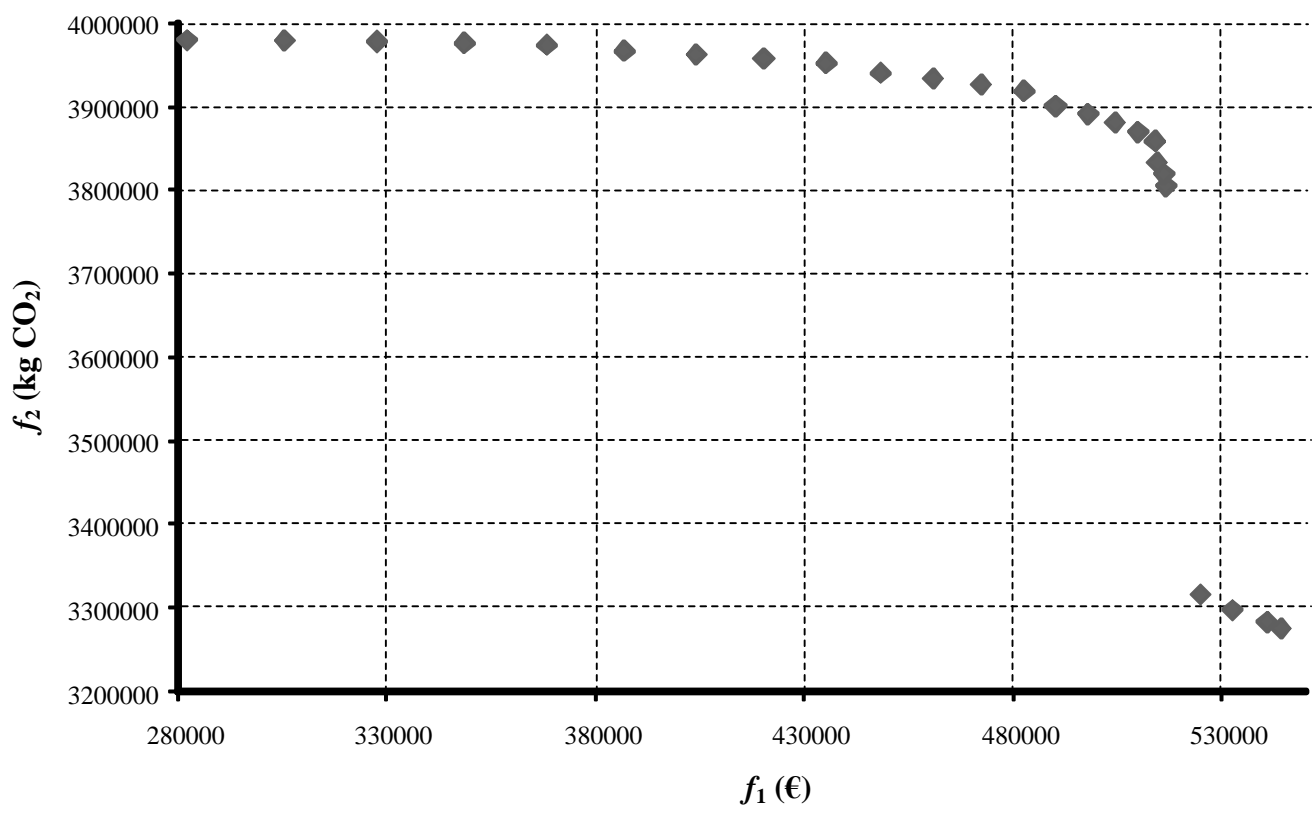



Figure 5

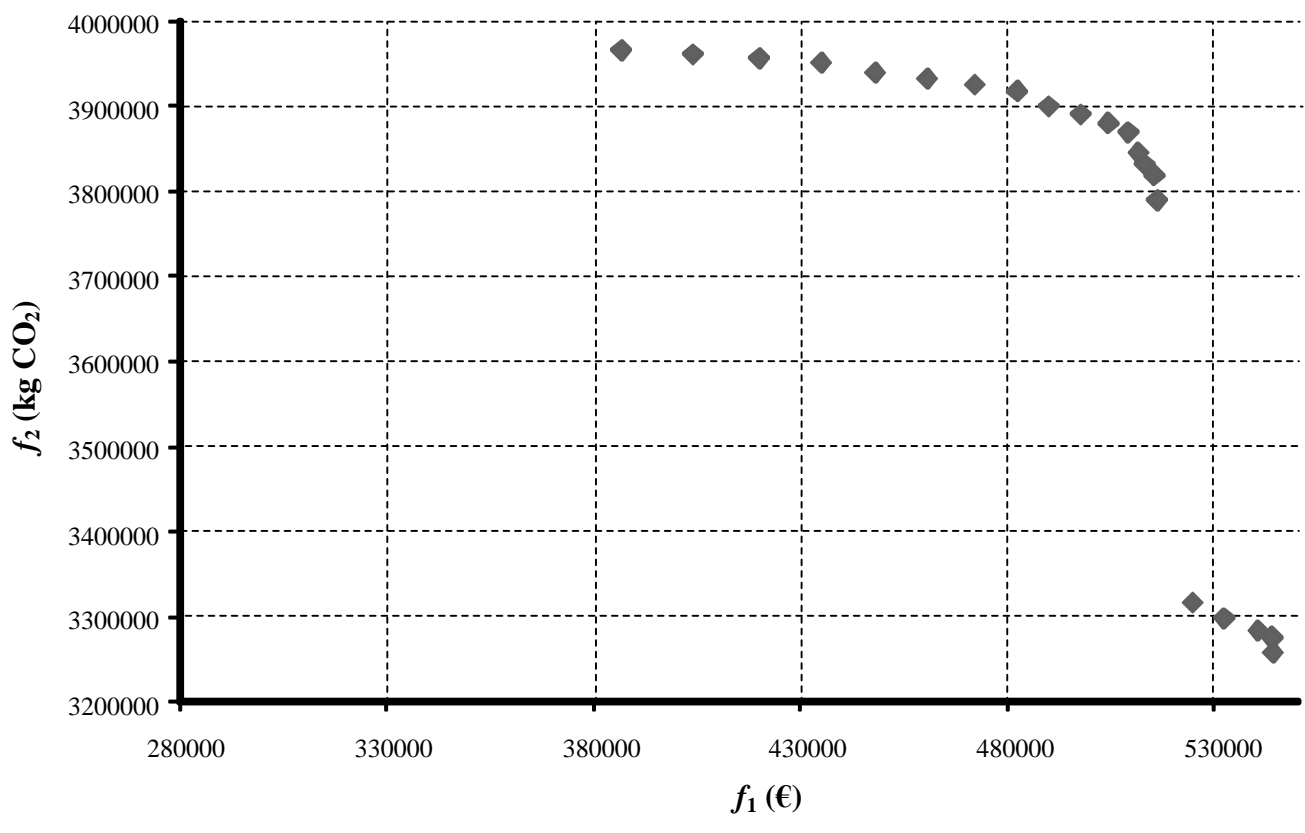



Figure 6

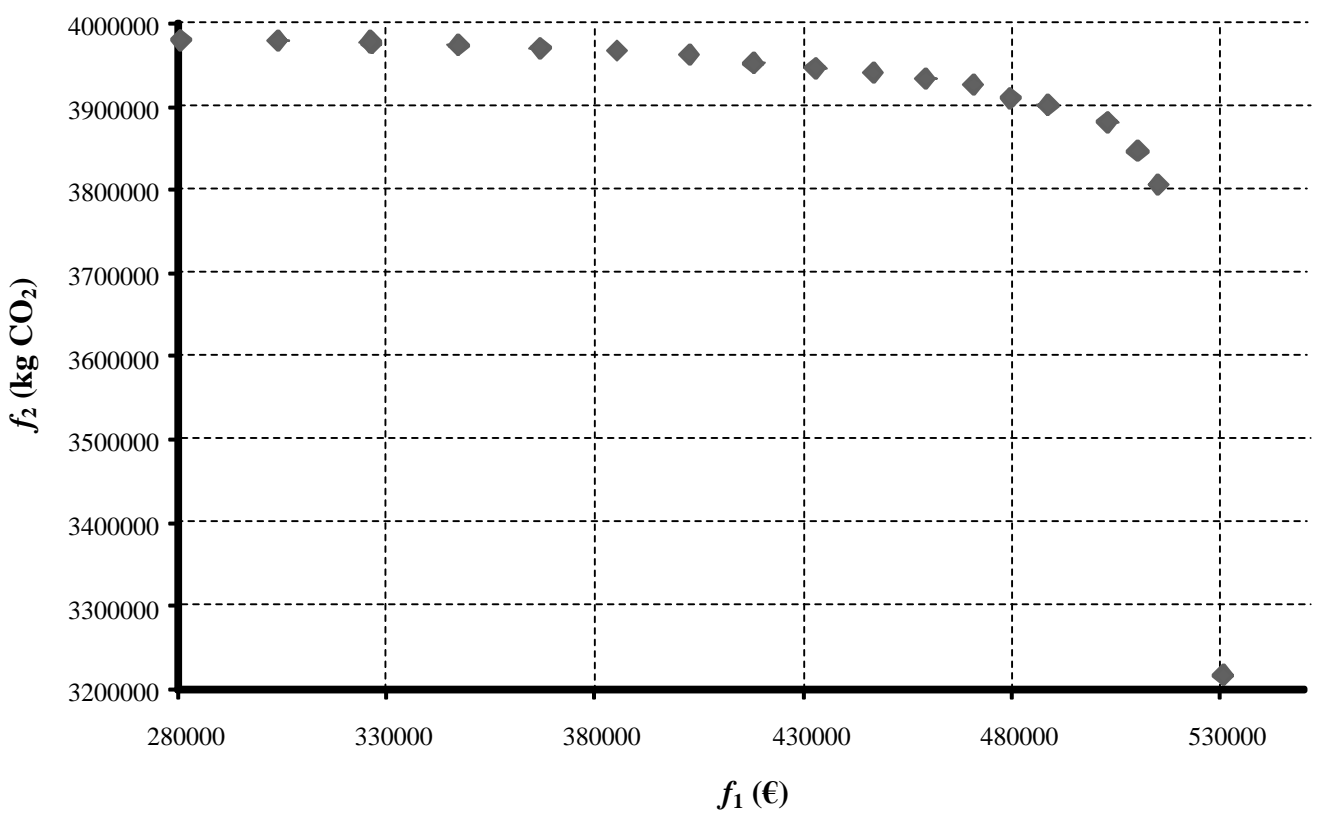

Figure 7

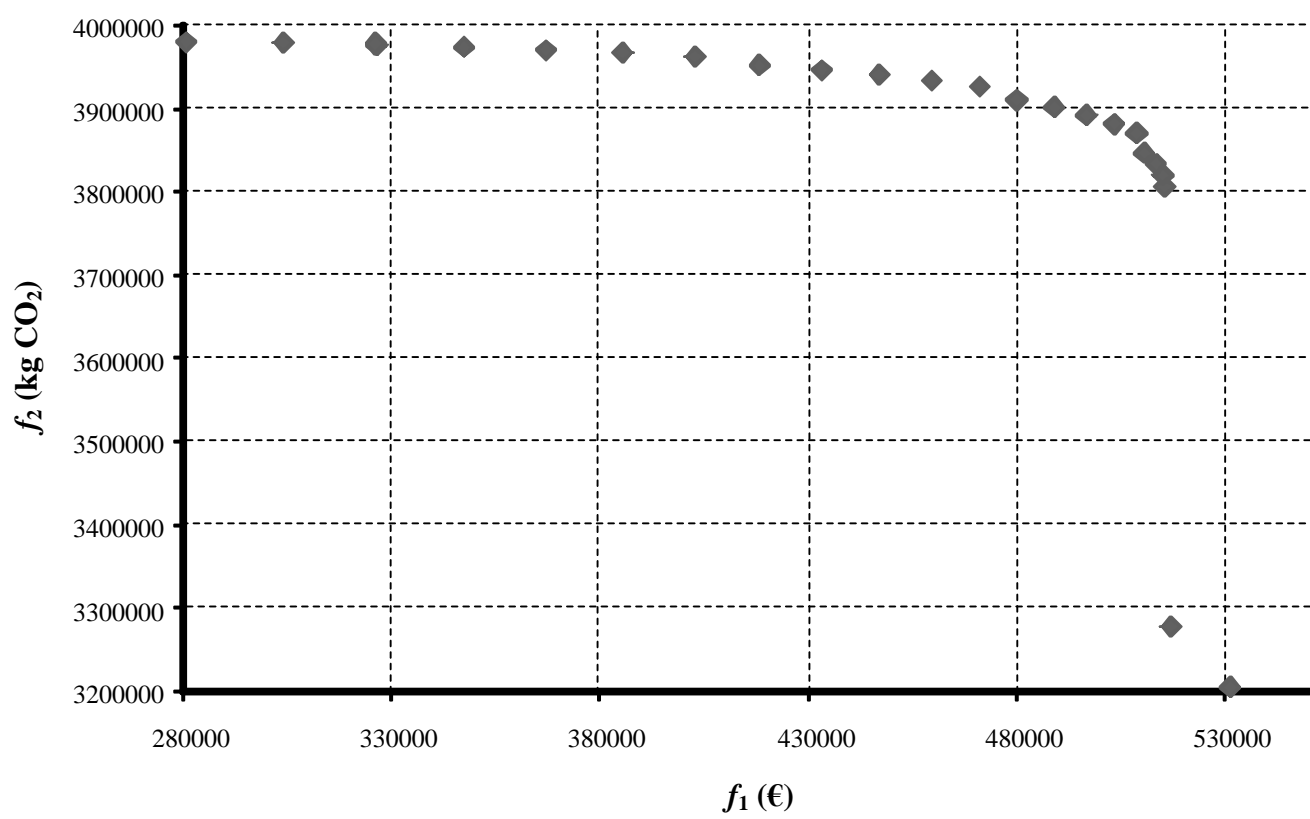

Figure 8

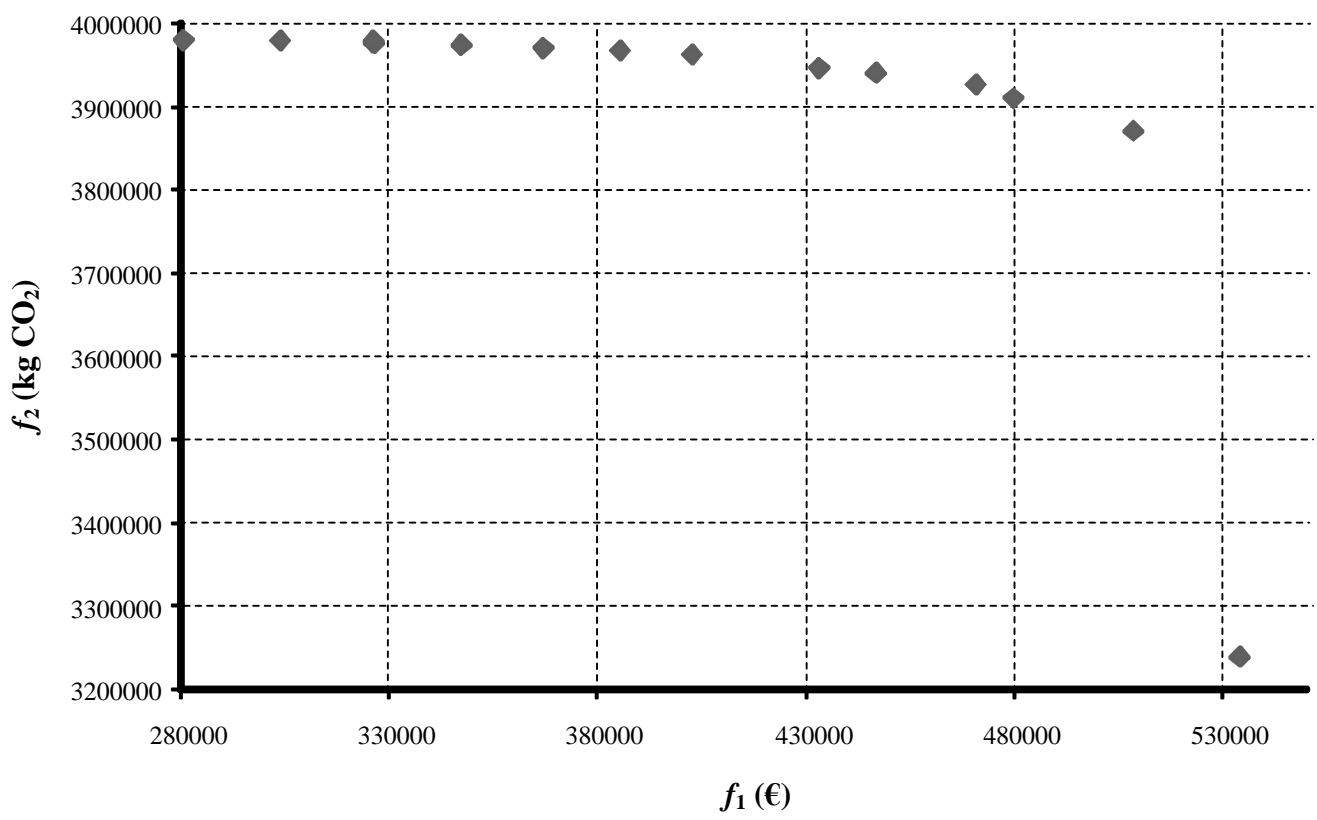

Figure 9  
[Click here to download high resolution image](#)

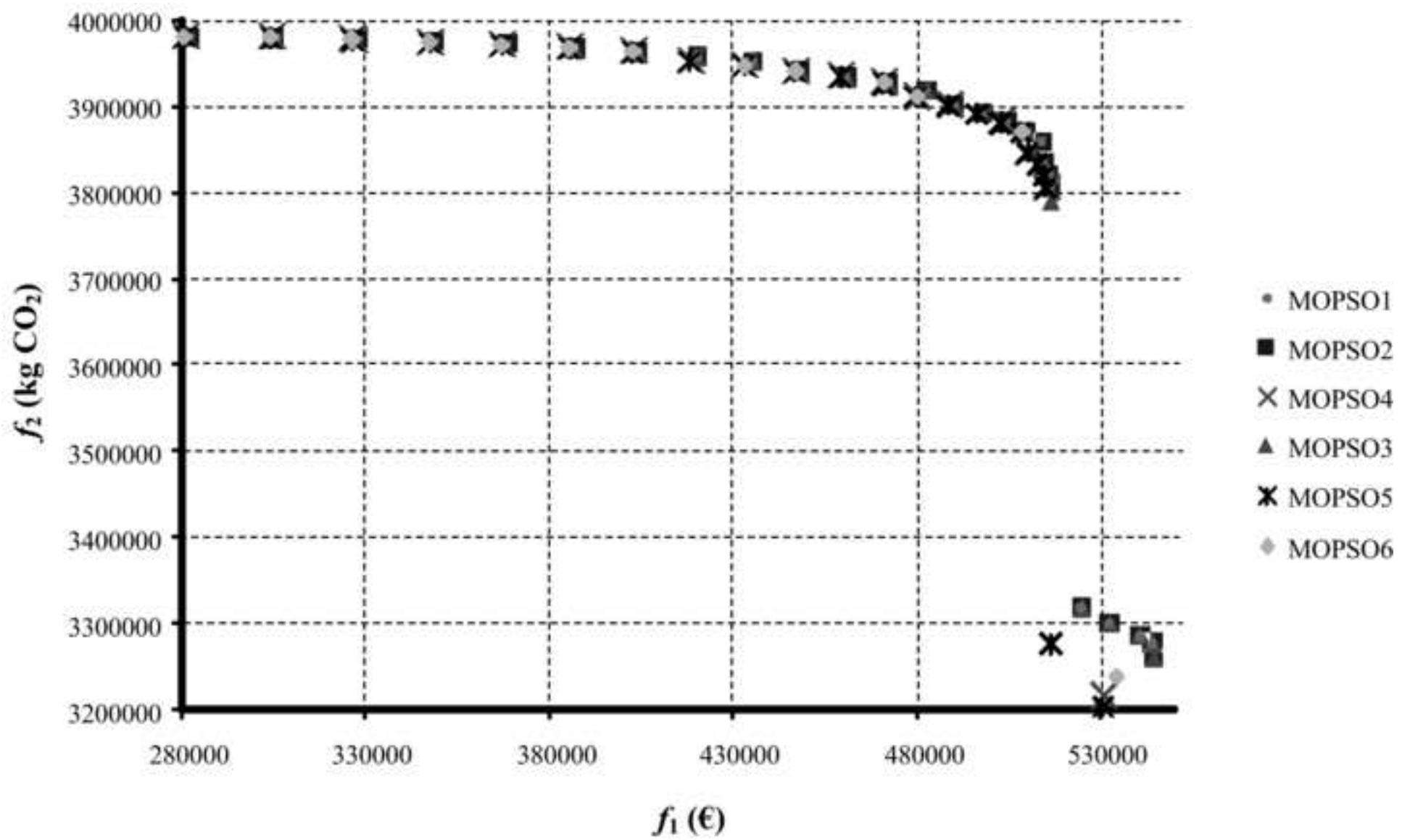

Figure 10

