



HAL
open science

Study of the digital camera acquisition process and statistical modeling of the sensor raw data

Cecilia Aguerrebere, Julie Delon, Yann Gousseau, Pablo Musé

► **To cite this version:**

Cecilia Aguerrebere, Julie Delon, Yann Gousseau, Pablo Musé. Study of the digital camera acquisition process and statistical modeling of the sensor raw data. 2013. hal-00733538v2

HAL Id: hal-00733538

<https://hal.science/hal-00733538v2>

Submitted on 6 Jun 2013 (v2), last revised 20 Aug 2014 (v4)

HAL is a multi-disciplinary open access archive for the deposit and dissemination of scientific research documents, whether they are published or not. The documents may come from teaching and research institutions in France or abroad, or from public or private research centers.

L'archive ouverte pluridisciplinaire **HAL**, est destinée au dépôt et à la diffusion de documents scientifiques de niveau recherche, publiés ou non, émanant des établissements d'enseignement et de recherche français ou étrangers, des laboratoires publics ou privés.

Study of the digital camera acquisition process and statistical modeling of the sensor raw data

C. Aguerrebere, J. Delon, Y. Gousseau, P. Musé

1 Introduction

The accurate modeling of the acquisition process in digital cameras is of great interest for a wide variety of domains concerning the use of digital images. In particular, it is of great utility in image processing, computational photography or computer vision applications. For instance, the statistical characterization of image data allows to develop denoising techniques suited to particular noise types, which perform much better than general techniques.

In the present report we present a detailed analysis of the digital image acquisition process which allows us to introduce a statistical model of the raw sensor data. The accuracy of this modeling is essential to its posterior utility. It is thus fundamental to take into account all different sources of noise and uncertainty in this model.

Several articles present and make use of statistical models of the sensor raw data [12, 6, 5, 7, 1]. Different levels of complexity can be found among them. In particular, a model similar to the one presented in this work can be found in [5, 7, 1]. Nevertheless, to the best of our knowledge, non of these articles present a detailed explanation of the physical origin of each noise source and the corresponding justification of the statistical model associated to each one. This rigorous analysis enables us to prioritize the different noise sources and obtain a simplified model still useful and realistic. Also we are able to consciously determine other aspects of the model, for instance, the relevance of considering spatially varying parameters.

2 Acquisition of digital images

Two technologies are used for camera sensors: charge-coupled devices (CCD) and complementary metal-oxide-semiconductors (CMOS). Even if the operation principles of both sensors differ, a very similar acquisition model can be proposed for both of them, illustrated by a simplified diagram in Figure 1. In short, CCDs and CMOS both transform incoming light photons into voltage output values. More precisely, these sensors are silicon-based integrated circuits including a dense matrix of photo-diodes that first convert light photons into electronic charge [11, 3]. Light photons interact with the silicon atoms generating electrons that are stored in a potential well. When the potential well is full, the pixel saturates, and no further electrons are stored¹. In the case of CCDs, the accumulated charge may then be efficiently transferred from one potential well to another across the chip, until reaching an output amplifier where the charge is converted to a voltage output value. This voltage is then quantified to give the corresponding pixel value. For the CMOS technology, the impinging photons are also accumulated in the photo-diodes. However, unlike CCDs, CMOS pixels have conversion electronics to perform the charge to voltage conversion at each location. This extra circuitry increases noise and generates extra fixed pattern noise sources compared to CCDs [3].

The main uncertainty sources at each stage of the acquisition process are described in more details

¹In this case, additionally generated electrons may spill over the adjacent wells, resulting in what is called *blooming*. This phenomena, well known in astronomic photography, is mostly observed with very long exposures. We neglect it in this paper.

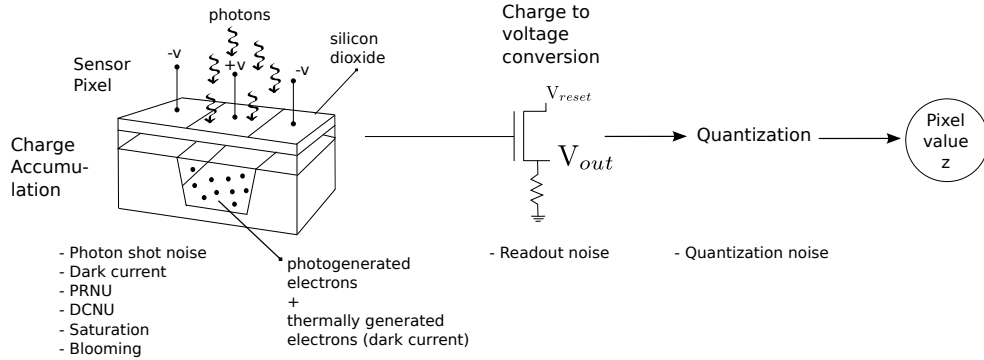

Figure 1: Simplified diagram of the main stages of the acquisition process and the principal noise sources at each stage.

in the following paragraphs, and listed by Figure 1. We divide them in two categories: random noise sources, and spatial non-uniformity sources.

2.1 Random noise sources

Two physical phenomena are responsible for the random noise generation during the camera acquisition process: the discrete nature of light, which is behind the photon shot noise, and thermal agitation, which explains the random generation of electrons inside the sensor when the temperature increases.

2.1.1 Photon shot noise

The number of photons C_i^p impinging the photo-diode p during a given exposure time τ_i follows a Poisson distribution, with expected value $C_p\tau_i$, where C_p is the radiance level in photons/unit-of-time reaching the photo-diode. If we suppose that an electron is generated for each absorbed photon (this depends on the photon energy, therefore on the considered wavelength), the number of electrons generated on the potential well is also Poisson distributed. In an ideal case with no other noise sources, the voltage measured at the sensor output should be proportional to the collected charge: $V = g_{cv}C_p\tau_i$, where $C_p\tau_i$ is the number of absorbed electrons, and where g_{cv} is the equivalent capacitance of the photo-diode.

2.1.2 Dark current

Some of the electrons accumulated on the potential well don't come from the photo-diode but result from thermal generation. These electrons are known as *dark current*, since they are present and will be sensed even in the absence of light. Dark currents can be generated at different locations in the sensor and they are related to irregularities in the fundamental crystal structure of the silicon, e.g. metal impurities (gold, copper, iron, nickel, cobalt) and crystal defects (silicon interstitials, oxygen precipitates, stacking faults, dislocations) [11]. For an electron to contribute to the dark current it must be thermally generated but also manage to reach the potential well. This last event happens independently for each electron. As a consequence, it can be shown that the number of electrons D^p thermally generated and reaching the potential well p is well modeled by a Poisson distribution with expected value D^p [11], depending on the temperature and exposure time. This noise is generally referred to as *dark current shot noise* or *dark shot noise*. In this paper, in order to make explicit the dependence on the exposure time τ_i , we name this dark shot noise D_i^p .

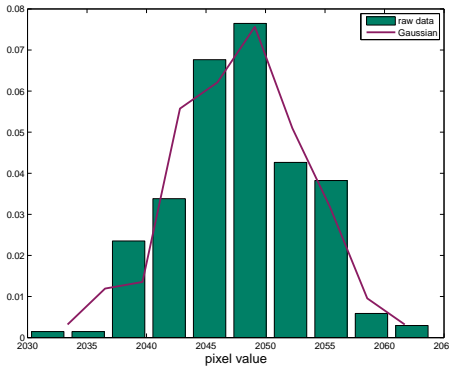

Figure 2: Readout noise. **Green:** histogram of the raw values taken by 200 realizations of one pixel acquired with virtually no light (realizations are obtained from 200 images acquired in a dark room with a Canon 7D set to its shortest exposure (1/8192.0 s) and with the cap on). **Violet:** histogram of 200 realizations of a Gaussian random variable with equal mean and variance as the raw data. The distribution of the raw pixels is accurately approximated by a Gaussian distribution.

2.1.3 Readout noise

In the readout stage of the acquisition process a voltage value is read for each pixel. This voltage is read as a potential difference from a reference level which represents the absence of light. Thermal noise \mathbf{N}_{reset} , inherent to the readout circuitry, affects the output values. In the literature, it is currently admitted that this noise is accurately modeled as Gaussian distributed [8]. It is also known as *reset noise*, in reference to the reference voltage, commonly named reset voltage.

Notice that modeling the noise source as Gaussian distributed means that pixels may take negative values. In practice, the reference voltage is assigned a large enough value in the AD conversion so that voltage values below the reference are assigned positive pixel values. For this reason, the raw data for an image taken with the cap on will give pixel values close to the offset value (e.g. 2048 for the 14 bits Canon 7D). Alike the raw pixels, the inverse of the camera response function $f^{-1}(z)$ may take negative values. Mostly for low radiance, after subtracting the offset the inverse of the camera response may take negative values.

The readout noise \mathbf{N}_{out} includes also the remaining circuitry noise sources between the photoreceptor and the AD circuitry. They are all thermally generated and thus modelled as Gaussian noise. Some other minor sources include frequency dependent noise (flicker noise) but we wont consider them in this analysis.

Figure 2 shows the histogram of the raw values taken by 200 realizations of one pixel. The 200 realizations are obtained from 200 images acquired in a dark room with a Canon 7D set to its shortest exposure (1/8192.0 s) and with the cap on. These images are known as bias frames. The camera acquires virtually no light thus the pixel values capture the readout noise in each pixel. The histogram of 200 realizations of a Gaussian random variable with equal mean and variance as the raw data is superposed for comparison. It can be verified that the Gaussian distribution accurately approximates the readout noise distribution. Moreover, this experience shows the presence of the offset value previously mentioned. Even if the images are acquired with no light, the mean pixel value is not zero but 2048.

2.2 Spatial non-uniformity sources

Besides random noise sources, several uncertainty factors, all related to the spatial non-uniformity of the sensor, should be taken into account in the acquisition model.

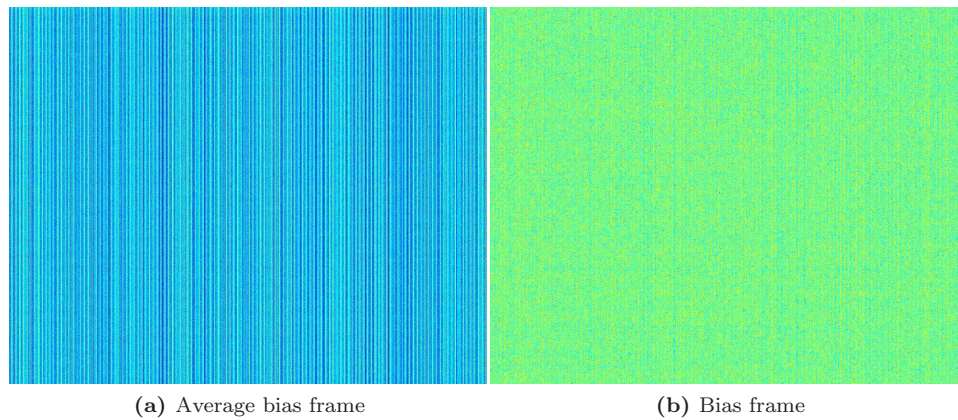

Figure 3: Column noise. **Left:** Average of 200 bias frames acquired with a CMOS sensor. **Right:** Bias frame acquired with a CMOS sensor.

2.2.1 Fixed pattern noise sources

Photo-response non-uniformity (prnu) The PRNU describes the differences in pixel responses to uniform light sources. Different pixels won't produce the same number of electrons from the same number of impacting photons. We assume one electron is generated per absorbed photon, but not all the impacting photons will be absorbed in the photo-diode. This is caused by variations in pixel geometry, substrate material and micro-lenses [4]. The effect of PRNU is proportional to illumination and is prominent under high illumination levels. This noise source is signal dependent since there is no PRNU in the absence of signal.

The fact that a photon can be absorbed or not in the photo-diode is a binomial selection of the Poisson process of impacting photons. Hence the PRNU can be modelled as a multiplicative factor a_p applied to the parameter of the Poisson variable \mathbf{C}_i^p .

Dark-current non-uniformity (dcnu) The DCNU represents the variations in dark current generation rates from pixel to pixel. This variation is intrinsic to the material characteristics of the sensor cells and causes variations in the expected value of the dark current from pixel to pixel. As the PRNU, the DCNU can be modelled as a multiplicative factor d_p applied to the parameter of the Poisson variable \mathbf{D}_i^p .

2.2.2 CCD specific sources

Transfer efficiency After charge is collected at each pixel, the CCD must transfer the charge to the output amplifier for readout. The transfer efficiency of a real CCD sensors is less than 1. Charge that is not correctly transferred is either lost or deferred to other transfers, affecting other pixels count values. Current buried-channel CCD transfer efficiency is above 0.99999 [2] thus it won't be taken into account in the acquisition model.

2.2.3 CMOS specific sources

Column noise The readout for CMOS sensors is performed line by line. At a given time, all columns of one line are readout through the output column amplifiers. Differences from one column amplifier to another introduce a column fixed pattern. Because the human eye is adapted to perceive patterns, column noise may be quite disturbing even if its contribution to the total noise is less significant than that of white noise [9].

Figure 3a shows the average of 200 bias frames acquired with a CMOS sensor (Canon 7D set to exposure time 1/8192.0 s). The column pattern on the readout noise is clearly visible. Figure 3b

Signal Dependent	Temperature Dependent	Exp. Time Dependent
Photon shot noise PRNU	Thermal noise Dark current	Photon shot noise Dark current shot noise Thermal noise

Table 1

shows an example of bias frame. Even if the column pattern is not so evident from just one frame, a subtle column pattern is still noticeable.

Other interesting classification of the noise sources than random or fixed pattern is according to their dependence on signal, temperature and exposure time. Table 1 shows a classifications of the different noise sources according to these aspects.

2.3 Quantization noise

A last source of noise in the acquisition process, specific to digital cameras, takes place during the conversion of the analog voltage measures into digital quantized values. This results in an additive, uniformly distributed, quantization error. The quantization noise is normally negligible compared to the readout noise [3, 2]. This is even more remarkable with modern cameras, which can easily have 12 or 14 bits for quantization.

2.4 Acquisition model

Equation (1) proposes a simplified model including the previously presented noise sources (the dependence on position p is avoided to simplify the notation):

$$\mathbf{Z}_i = f([g_{cv}(\mathbf{C}_i + \mathbf{D}_i) + \mathbf{N}_{reset}]g_{out} + \mathbf{N}_{out} + \mathbf{Q}), \quad (1)$$

where f is the camera response function, \mathbf{Z}_i is the raw pixel value, \mathbf{C}_i is a Poisson variable of parameter $aC\tau_i$, \mathbf{D}_i is a Poisson variable of parameter dD_i . In the case of RAW data, f is a linear function of slope 1 before attaining a saturation threshold (see Figure 4). After this saturation threshold, values are clipped (f becomes a constant). Equation (1) can be rewritten as the addition of a Poisson distributed random variable with expected value $\lambda_i = aC\tau_i + dD_i$, a Gaussian distributed noise component $\mathbf{N}_R = g_{out}\mathbf{N}_{reset} + \mathbf{N}_{out}$ with mean μ_R and variance σ_R^2 , and the uniformly distributed quantization error \mathbf{Q} :

$$\mathbf{Z}_i = f(g\text{Poiss}(\lambda_i) + \mathbf{N}_R + \mathbf{Q}), \quad (2)$$

with $g = g_{cv}g_{out}$. A similar model is presented by Foi et al. in [1], where they propose to model digital camera raw data as a mixed Gaussian-Poisson model. The difference between the models is the inclusion of the gain g_{cv} , modeling charge to voltage conversion. This constant is not included in Foi et al. model, but the general idea remains the same.

The previous model is valid for both CCD and CMOS sensors. In the CCD case, the readout noise sources can be considered as identical for all pixels. Thus g , μ_R and σ_R^2 are spatially constant. On the contrary, in order to model column noise for CMOS sensors, different g , μ_R and σ_R^2 parameters should be considered for each column.

Regarding the relative importance of each noise source, various articles agree in concluding that under low illumination conditions, the primary noise source is the reset noise, while for high illumination the major noise source is the photon shot noise [3, 2].

2.5 Simplified acquisition model

For the values normally taken by $\lambda = aC\tau_i + dD_i$, the Poisson distribution can be correctly approximated by a Gaussian distribution with mean and variance equal to λ . Moreover, the dark

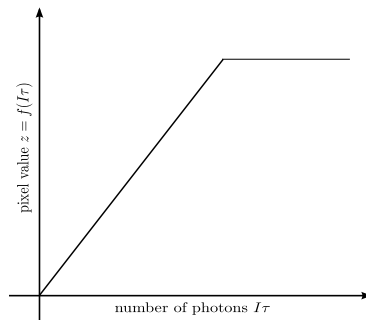

Figure 4: Camera response function for the lineal + saturation model.

current can be neglected for exposure times below 1s [10] and it is commonly admitted that the quantization noise is negligible compared to the readout noise [3, 2]. Thus the model (2) can be simplified into

$$f^{-1}(\mathbf{Z}_i) \sim N(gaC\tau_i + \mu_R, g^2aC\tau_i + \sigma_R^2). \quad (3)$$

with σ_R^2 the variance of \mathbf{N}_R . In the following sections, we will always assume that the camera response f is linear before saturation (recall that we work with RAW data). Including the slope of f into the gain g , for non saturated samples the model becomes

$$\mathbf{Z}_i \sim N(gaC\tau_i + \mu_R, g^2aC\tau_i + \sigma_R^2). \quad (4)$$

which leads a simple yet realistic representation of raw sensor data.

References

- [1] V. KATKOVNIK A. FOI, M. TRIMECHE AND K. EGIAZARIAN, *Practical poissonian-gaussian noise modeling and fitting for single-image raw-data*, IEEE Transactions on Image Processing, 17 (2008), pp. 1737–1754.
- [2] G.E. HEALEY AND R. KONDEPUDY, *Radiometric ccd camera calibration and noise estimation*, IEEE Transactions on Pattern Analysis and Machine Intelligence, 16 (1994), pp. 267–276.
- [3] A. NEMIROVSKY I. BROUK AND Y. NEMIROVSKY, *Analysis of noise in cmos image sensor*, in Microwaves, Communications, Antennas and Electronic Systems, 2008. COMCAS 2008. IEEE International Conference on, may 2008, pp. 1–8.
- [4] K. UNSWORTH K. IRIE, A. E. MCKINNON AND I. M. WOODHEAD, *A model for measurement of noise in CCD digital-video cameras*, Measurement Science and Technology, 19 (2008).
- [5] K. KIRK AND H. J. ANDERSEN, *Noise characterization of weighting schemes for combination of multiple exposures*, in BMVC, 2006, pp. 1129–1138.
- [6] S. BORMAN M. A. ROBERTSON AND R. L. STEVENSON, *Estimation-theoretic approach to dynamic range enhancement using multiple exposures*, J. Electronic Imaging, 12 (2003), pp. 219–228.
- [7] M. WAND C. THEOBALT H. P. SEIDEL M. GRANADOS, B. AJDIN AND H. P. A. LENSCH, *Optimal hdr reconstruction with linear digital cameras*, in CVPR, 2010, pp. 215–222.
- [8] R. MANCINI, *Op Amps for everyone*, Texas Instruments, Aug 2002.
- [9] E. MARTINEC, *Noise, dynamic range and bit depth in digital slrs. pattern noise*. <http://theory.uchicago.edu/~ejm/pix/20d/tests/noise/#patternnoise>. Accessed: 03/08/2012.

- [10] ———, *Noise, dynamic range and bit depth in digital slrs. thermal noise*. <http://theory.uchicago.edu/~ejm/pix/20d/tests/noise/#shotnoise>. Accessed: 03/08/2012.
- [11] A. J. P. THEUWISSEN, *Solid-State Imaging with Charge-Coupled Devices*, (1996), pp. 94–108.
- [12] V. RAMESH Y. TSIN AND T. KANADE, *Statistical calibration of the ccd imaging process*, in ICCV, 2001, pp. 480–487.