



**Assessing Operational Complexity of Manufacturing Systems Based on Statistical Complexity**

Journal:	<i>International Journal of Production Research</i>
Manuscript ID:	TPRS-2010-IJPR-1144.R1
Manuscript Type:	Original Manuscript
Date Submitted by the Author:	03-Feb-2011
Complete List of Authors:	Vrabič, Rok; University of Ljubljana, Department of Control and Manufacturing Systems Butala, Peter; University of Ljubljana, Department of Control and Manufacturing Systems
Keywords:	MANUFACTURING CONTROL SYSTEMS, PERFORMANCE MEASURES, SIMULATION
Keywords (user):	COMPLEXITY

SCHOLARONE™  
Manuscripts

## Assessing Operational Complexity of Manufacturing Systems Based on Statistical Complexity

Rok Vrabič, Peter Butala

*Department of Control and Manufacturing Systems, University of Ljubljana, Ljubljana, Slovenia*

\*Corresponding author:

Rok Vrabič,

University of Ljubljana, Faculty of Mechanical Engineering,

Aškerčeva 6,

SI-1000 Ljubljana,

E-mail: [rok.vrabic@fs.uni-lj.si](mailto:rok.vrabic@fs.uni-lj.si)

Phone: +386 1 4771 744

Peter Butala,

University of Ljubljana, Faculty of Mechanical Engineering,

Aškerčeva 6,

SI-1000 Ljubljana,

E-mail: [peter.butala@fs.uni-lj.si](mailto:peter.butala@fs.uni-lj.si)

Phone: +386 1 4771 753

### Acknowledgements

This work was partially supported by the Ministry of Higher Education, Science and Technology of the Republic of Slovenia, Grant No. 1000-08-310127, and by the Slovenian Research Agency, Grant No. P2-0270.

## Assessing Operational Complexity of Manufacturing Systems Based on Statistical Complexity

The aim of this paper is to contribute to complex systems thinking in manufacturing organisations through the development of a metric for operational complexity. Operational complexity is concerned with the temporal aspects of coordination and control in manufacturing systems. Statistical complexity from computational mechanics theory is proposed as the metric. The metric can potentially be used to support decision making by objective assessment of complexity. The properties of the metric are explored through simulation studies. The simulation results confirm that the proposed metric captures the intuitive notion of complexity. It is shown that operational complexity is influenced by internal factors such as system structure, as well as external ones such as demand, and that complexity can be managed through the application of appropriate control methods. A case study is presented that applies the metric to real production data. The case study shows that the global recession had resulted in a decreased operational complexity of outputs.

Keywords: manufacturing systems, complexity, statistical complexity

### 1 Introduction

Modern business organisations are operating in an uncertain and constantly changing environment. Their performance and survival are largely determined by their management of change. Conventional theories of management lack the tools to describe, analyse, and manage the growing complexity, and can, in turn, no longer cope with the issues it gives rise to.

This holds particularly true for manufacturing companies. They are subjected to opportunities and constraints of the global market, cooperating and competing at the same time. While operating in an environment full of disturbances, their main challenge is how to ensure a stable and deterministic delivery of products in spite of the stochastic nature of demand.

A possible approach is offered by interdisciplinary research broadly termed “complexity science,” which develops new methods for studying regularities in systems. At its core is an assumption that simple rules and interactions cause complex effects. Although complex systems are frequently unpredictable, they also exhibit

1  
2  
3 precise regularities and patterns. These can be used to create strategies that can deal  
4  
5 with uncertainty, reduce risk, and expand opportunities of contemporary business  
6  
7  
8 (Buchanan, 2004).  
9

10  
11 Manufacturing companies must deal with two kinds of complexity: the  
12  
13 organisation of departments, shop floors, and supply chains on one hand, and the  
14  
15 management of the temporal aspects of coordination and control on the other. The  
16  
17 former is often termed structural complexity, while operational complexity denotes  
18  
19 the latter (Peklenik, 1995). It is hypothesized that by measuring and understanding  
20  
21 both, manufacturing organizations will find more efficient ways of operating in the  
22  
23 global environment (Wiendahl and Scholtissek, 1994). While structural complexity  
24  
25 has already received some attention in literature, operational complexity remains  
26  
27 relatively poorly studied.  
28  
29  
30

31  
32 **The principal motivation for the studies of complexity in manufacturing is the**  
33  
34 **search for methods that would allow us to reduce the degree of complexity and make**  
35  
36 **the manufacturing system more productive and predictive (Hon, 2005).** In  
37  
38 manufacturing control, complexity assessment has practical value for comparison of  
39  
40 control methods, for decision analysis, and for the understanding of the control  
41  
42 process, especially its complex properties such as self-organization and emergence.  
43  
44 The goal is to increase the predictability of the manufacturing system behaviour  
45  
46 despite the incompleteness of information, disturbances, and uncertainties inherent to  
47  
48 the environment by analyzing the complexity of the control method.  
49  
50  
51

52  
53 In order to make complexity analysis a practical approach, complexity must be  
54  
55 made measurable. Complexity metrics must be calculable and generally applicable.  
56  
57 Only as such can they be used for performance measurement and ultimately provide a  
58  
59 link between strategy and execution (Melnik et al., 2004).  
60

1  
2  
3 In this paper, statistical complexity from computational mechanics theory is  
4 proposed as a metric for the operational complexity of manufacturing systems.  
5

6  
7  
8 Statistical complexity measures the difficulty of process prediction. The abstraction  
9 behind statistical complexity is related to symbolic dynamics, wherein a signal is  
10 replaced by a sequence of symbols. This sequence is then used as a basis for the  
11 reconstruction of an algorithmic automaton. The statistical complexity is the entropy  
12 of this automaton's states. This approach provides a practical algorithm for the  
13 calculation of the complexity of real systems.  
14  
15  
16  
17  
18  
19  
20  
21  
22

## 23 **2 Background**

24 Manufacturing systems exhibit both fundamental components of complexity:  
25 complexity of structure and complexity of operation. Structural complexity can  
26 remain unchanged for longer periods of time. On the other hand, operational  
27 complexity is continuously influenced by numerous factors such as changes in  
28 demand, machine breakdowns, and control methods. Control, in general, provides a  
29 lever that can be used to influence the system's behaviour. Operational complexity  
30 can therefore only be understood through a closer examination of control.  
31  
32  
33  
34  
35  
36  
37  
38  
39  
40  
41

### 42 **2.1 The Manufacturing Control Problem**

43 Baker (1998) defines manufacturing control as the actuation of a manufacturing  
44 system to make products that takes into consideration the present and past observed  
45 states of the manufacturing system, as well as economic demand. He proposes a  
46 cybernetic model of control wherein the manufacturing system and the control system  
47 form a typical feedback loop. While Baker's definition will be adopted throughout  
48 this paper, his feedback model fails to capture important properties of manufacturing  
49 control systems.  
50  
51  
52  
53  
54  
55  
56  
57  
58  
59  
60

1  
2  
3 Firstly, information obtained through the observation of real-life systems is  
4 usually incomplete. Furthermore, it is prone to subjective interpretation wherever  
5 human subjects are involved. As the toughest problems in manufacturing control are  
6 not problems of optimization, but those of a subjective nature, a clearer definition of  
7 the role played by human subjects is required. A cybernetic model based on  
8 Peklenik's (1988) manufacturing cybernetics theory is presented in Figure 1.  
9  
10  
11  
12  
13  
14  
15  
16

17 A manufacturing control system encompasses the whole decision process,  
18 including subjects' decisions, leading to the control signals for the manufacturing  
19 plant. The information about the inputs and outputs of the plant is acquired by sensory  
20 and other processes. The goals are expressed as desired outputs. The control algorithm  
21  $\phi$  describes how control signals are generated based on the goals, the input, and the  
22 output information.  
23  
24  
25  
26  
27  
28  
29  
30  
31

32 The control problem resists formal description, especially when subjects and  
33 their decision making are taken into consideration as well. Nevertheless, the problem  
34 can be stated as: How to best satisfy the given goals of a manufacturing system,  
35 subjected to disturbances, by making decisions based on incomplete data?  
36  
37  
38  
39  
40

41 To provide an answer to the control problem, we need metrics for the  
42 evaluation of solutions. The difficulty in creating such metrics lies in the fact that  
43 every manufacturing system has unique properties; general metrics are therefore hard  
44 to find. One possibility is to take the approaches from complexity science and apply  
45 them to the manufacturing domain. The main hypothesis here is that manufacturing  
46 control can be improved if its complexity is measured and analyzed.  
47  
48  
49  
50  
51  
52  
53  
54  
55

## 56 ***2.2 Information Theory Approaches to Manufacturing Complexity***

57 As models are specific to a system or phenomenon, a general approach towards  
58 complex systems control is difficult to formulate. A promising approach to this  
59  
60

1  
2  
3 problem was found in information theory, which allows us to treat different complex  
4 systems on an equal footing.  
5  
6

7  
8 Information theory is well established in complexity science. It provides a  
9 well-developed theoretical basis, mathematical definitions, and computational tools.  
10  
11 The theory was first established by Shannon (1948). It provides a measure of  
12 uncertainty as a function of probabilities, known as the Shannon entropy (1).  
13  
14

$$15 \quad H(X) = -\sum_{x \in \mathcal{X}} P(x) \log_2(P(x)) \quad (1)$$

16  
17  $H(X)$  is a measure of uncertainty or of information about a random variable. It  
18 quantifies how much information one is missing when one does not know the value of  
19 a random variable.  
20  
21

22 Entropy is often associated with complexity, because intuitively, the more  
23 uncertain an observer is about the observed process, the more complex the process  
24 appears. This is studied by Shafiei-Monafred and Jenab (2010) for the case of  
25 operations in demand-based manufacturing. They show how human subjects learn to  
26 perform a task in less time and then define complexity of manufacturing operations  
27 based the learning curve model.  
28  
29

30 In the manufacturing domain, several complexity metrics are based on the  
31 Shannon entropy.  
32  
33

34 Frizelle and Woodcock (1995) define two types of complexity, static and  
35 dynamic complexity, which correspond to the aforementioned structural and  
36 operational complexity.  
37  
38

39 Static complexity is defined as the expected amount of information necessary  
40 to describe the state of a manufacturing system. The measure is based on the  
41 probability of a resource occupying a state.  
42  
43  
44  
45  
46  
47  
48  
49  
50  
51  
52  
53  
54  
55  
56  
57  
58  
59  
60

1  
2  
3  
4  
5  
6  
7  
8  
9  
10  
11  
12  
13  
14  
15  
16  
17  
18  
19  
20  
21  
22  
23  
24  
25  
26  
27  
28  
29  
30  
31  
32  
33  
34  
35  
36  
37  
38  
39  
40  
41  
42  
43  
44  
45  
46  
47  
48  
49  
50  
51  
52  
53  
54  
55  
56  
57  
58  
59  
60

Dynamic complexity is the expected amount of information necessary to describe the state of a system deviating from schedule due to uncertainty. The calculation involves the measurement of the difference between actual performance of the system and the expected figures in the schedule.

Frizelle's complexity metrics have been used and developed further in the work of Efstathiou (1998), Sivadasan (2002), Huaccho Huatuco (2009), and Isik (2010).

ElMaraghy et al. define an entropic complexity metric for manufacturing system configurations (2005). They introduce a complexity coding system to capture the variety and amount of information present in a given manufacturing system and its components.

An entropic definition of complexity is introduced for mixed-model assembly lines by Hu et al. (2008), and Wang and Hu (2010), wherein the authors argue that complexity is introduced by product variety. This is also considered by Jenab and Liu (2010) who present a graph-based model for the relative complexity of products.

The above approaches relate complexity to entropy and thus uncertainty. A useful interpretation of this is that entropy measures the amount of information one gains by looking at the actual state of a system. If the system is complex, a lot of information is gained, and vice versa. These methods therefore provide a way of looking at the structural complexity of the system. Even Frizelle's dynamic complexity, which captures the uncertainty of a schedule, is defined for a certain state in time. Operational complexity should, on the other hand, capture how a system evolves in time.

The only approach that explicitly studies temporal aspects of manufacturing systems is presented in (Frizelle and Suhov, 2001), wherein the authors apply the



1  
2  
3 Kolmogorov-Sinai entropy to Markovian queues. Complexity is associated with the  
4  
5 limiting rate of the entropy production in an observed process, and can be interpreted  
6  
7 as the randomness of behaviour in the sense of algorithmic complexity. It has been  
8  
9 argued, however, that randomness is not complex, as it easily yields to statistical  
10  
11 description. This notion is explored further in the following Section.  
12  
13  
14

### 15 16 **3 Measuring Operational Complexity**

17 A well-known approach to the complexity assessment of a process through the  
18  
19 examination of the sequence of symbols produced by it is the Kolmogorov-Chaitin  
20  
21 complexity. It is defined as the length of the shortest program capable of producing  
22  
23 the sequence. By this definition, periodic sequences are not complex, as repeating  
24  
25 patterns are easily encoded. Random sequences, on the other hand, are considered  
26  
27 complex, as they cannot be compressed into a shorter description.  
28  
29  
30  
31

32 Consider the example of flipping a fair coin. Although the sequence produced  
33  
34 by repeating a coin flip is random, coin flipping is intuitively not complex. This is  
35  
36 because the intuitive notion of complexity is not associated with the produced  
37  
38 sequence but with the underlying process. A coin flipping process is easy to describe  
39  
40 in a statistical way: there is a fifty percent chance of heads and a fifty percent chance  
41  
42 of tails. Albeit statistical, the description allows for prediction. Even if one cannot  
43  
44 know whether the next outcome will be heads or tails, one can make an accurate  
45  
46 prediction about the distribution of outcomes over future trials.  
47  
48  
49  
50

51 In the above sense, complexity is associated with the difficulty of predicting a  
52  
53 process, in other words, with the difficulty of discovering the patterns present in the  
54  
55 process.  
56

57 This is readily applicable to the control problem and associated operational  
58  
59 complexity. If a manufacturing system's states and outputs are easy to predict, the  
60

1  
2  
3 system is not complex. On the other hand, if making predictions is difficult, the  
4  
5 system is complex. An operational complexity metric should therefore quantify how  
6  
7 difficult it is to predict the future of the system.  
8  
9

10 Figure 2 presents the complexity curve from the control problem perspective.  
11  
12 The complexity curve relates complexity to disorder. Perfectly ordered and perfectly  
13  
14 disordered processes have zero complexity. In between, the complexity increases to a  
15  
16 point where it becomes incomputable due to the observer's limitations. The area  
17  
18 beyond that point is commonly termed "the edge of chaos".  
19  
20  
21

22 As stated in the control problem definition, one of the goals of control is to  
23  
24 make the outputs more deterministic. This, however, is countered by the nature of the  
25  
26 inputs, by disturbances, and by the control and manufacturing processes themselves.  
27  
28 The more complex these influences, the harder it is to predict the output.  
29  
30  
31

32 On their way towards becoming outputs (products), inputs (orders, demand)  
33  
34 go through a transformation process. At first, they can usually be described  
35  
36 statistically accurately with e.g. the Poisson arrival model. Then, as they are  
37  
38 scheduled, they transform into manufacturing system states. Their description  
39  
40 becomes dependant on the manufacturing system itself. Patterns emerge, depending  
41  
42 both on the structure of the manufacturing system as well as on the control method.  
43  
44 Complexity increases. Finally, the states are transformed into outputs. Outputs can be  
45  
46 considered a coarser description than the states, as different state sequences can lead  
47  
48 to the same outputs. Complexity decreases again, as the outputs are in general easier  
49  
50 to predict than complete system states.  
51  
52  
53  
54

55 In light of this, the following Section formally defines an operational  
56  
57 complexity metric.  
58  
59  
60

### 3.1 Statistical Complexity

Statistical complexity attempts to measure the size of the minimum program capable of statistically reproducing the patterns in a data set. It originates in the computational mechanics approach to pattern discovery (Shalizi and Crutchfield, 2001), which has been applied to various fields ranging from molecular systems (Nerukh et al., 2002) to the stock market (Park et al., 2006). The following is a brief illustration of the approach. For a detailed derivation we refer to (Shalizi and Crutchfield, 2001).

#### 3.1.1 Definition

A stream of data of infinite length  $X$  is split at a chosen point  $x_t$  into two sequences

(2). The sequence up to  $x_t$  is denoted  $\bar{x}$ , and the sequence from  $x_{t+1}$  on is denoted  $\bar{x}'$ .

$$X = \underbrace{\dots, x_{t-2}, x_{t-1}, x_t}_{\bar{x}}, \underbrace{x_{t+1}, x_{t+2}, \dots}_{\bar{x}'} \quad (2)$$

Causal states  $S_i$  are defined as sets of  $\bar{x}$  for which the probability of an  $\bar{x}'$  is the same for every  $\bar{x}$ . The set of causal states is denoted by  $S$ .

Causal states, together with their transition probabilities, construct an  $\varepsilon$ -machine – a minimal model of the process. It has been proven in (Shalizi and Crutchfield, 2001) that causal states are maximally accurate predictors and that their state-to-state transitions are minimally stochastic.

The statistical complexity  $C_\mu$  is the Shannon entropy (1) over the distribution of causal states (3).  $P(S_i)$  denotes the probability of the  $\varepsilon$ -machine being in state  $S_i$ .

$$C_\mu = - \sum_{S_i \in S} P(S_i) \log_2 P(S_i) \quad (3)$$

The statistical complexity measures the average amount of historical memory stored in the process. In a complex process, more information about the past is stored internally. Prediction therefore requires more information and is, in turn, more difficult.

1  
2  
3 An interesting property of statistical complexity is that it is an upper bound of  
4 excess entropy  $E$  (Shalizi and Crutchfield, 2001), which is the mutual information of  
5 the processes semi-infinite past and semi-infinite future (4). This allows for another  
6 interpretation of statistical complexity. The memory needed to perform an optimal  
7 prediction is greater or equal to the amount of information that the past provides about  
8 the future.  
9  
10  
11  
12  
13  
14  
15  
16

$$E = I(\bar{x}, \bar{x}) \leq C_{\mu} \quad (4)$$

17  
18  
19  
20 The illustration of the  $\varepsilon$ -machine concept is provided in Figure 3, where  $\varepsilon$ -  
21 machines are shown for completely random and completely deterministic processes.  
22  
23  
24

25 The random process (A – e.g. coin-flipping) has the statistical complexity of  
26 zero. The deterministic process (B) has the statistical complexity of one bit. This is  
27 because only one previous state has to be remembered to optimally predict the one  
28 that follows it. The same process can be encoded differently (C) and have a different  
29 statistical complexity. Considerations in this regard are analyzed in Section 3.3.  
30  
31  
32  
33  
34  
35  
36  
37

### 38 **3.1.2 Calculation**

39 Statistical complexity can be estimated by considering finite lengths of the symbolic  
40 sequence under observation. Shalizi C.R. and Shalizi K.L. (2004) present a Causal-  
41 State Splitting Reconstruction (CSSR) algorithm, which is able to reconstruct the  $\varepsilon$ -  
42 machine of the process. Although the approach offers great practicality, there are also  
43 some limitations to it.  
44  
45  
46  
47  
48  
49  
50

51 The maximum history length considered,  $L_{max}$ , is an adjustable parameter. It is  
52 shown that for periodic processes, the lower bound of  $L_{max}$  is the period. The upper  
53 bound is limited by adequate sampling to the order of the logarithm of the whole  
54 sequence length,  $\log(N)$ .  
55  
56  
57  
58  
59  
60

### 3.2 Observation Levels

In complex systems, the observer plays a crucial role. Emergence, as the defining phenomenon of complex systems, has no meaning without an observer. Because emergence is the occurrence of something new, it has to be specified for whom it is new.

Consider an example of a manufacturing system. Machine operators, production managers, and business managers all observe the same system. Their views are partial and acquired on different structural and temporal scales. The operators mainly deal with single elements of the system. The production managers are concerned with the state of the system as a whole. Lastly, the business managers are mostly interested in system outputs. Temporal scales vary as well, from seconds at the operator level to days at the business level.

Resolution of observation is subjective, giving rise to two questions: Can different levels of observation of the same system co-exist, and, if they can, how to determine the optimal level of observation and optimal type of description?

Shalizi and Moore (2003) argue that different levels of observation of the same system can co-exist from the perspective of computational mechanics theory. Comparing a fine and a coarse-grained description, each may have its own, coherent causal account, which gives legitimacy to using different resolutions and time scales in describing the same process.

Shalizi (2001) furthermore suggests that the optimal level is determinable and defines it as the level at which the ratio of the extent of predictability to the difficulty of prediction is highest (Prokopenko et al., 2009). This metric has been termed “efficiency of prediction”,  $e$  (5), and is defined as the quotient of excess entropy (4) and statistical complexity (3).

$$e = \frac{E}{C_{\mu}} = \frac{\text{How much can be predicted.}}{\text{How difficult it is to predict.}} \quad (5)$$

It can be interpreted as the fraction of historical memory stored in the process, which is useful in telling us about the future. Given two possible observation levels, the one with higher efficiency of prediction should be chosen.

These concepts are studied in the following Section, where the operational complexity metric is applied to a simulated system. The simulation results are observed on different levels and with different encodings.

#### 4 Simulation Experiments

Three groups of simulation experiments are carried out to analyze the properties of the proposed operational complexity metric. The first group studies the effect of the control algorithm on complexity. The second group shows how structural complexity affects the operational complexity and the implications of observing this on different levels. Finally, the third group studies the introduction of periodicity into the control algorithm.

##### 4.1 Problem Formulation

A simulation model of a simple make-to-order manufacturing system is developed. The system consists of two machines, both capable of processing two types of jobs. Jobs have fixed processing times and due times, relative to arrival times. Job processing cannot be interrupted. The Poisson arrival model is used for job arrival times. For successful completion in due time, the system receives a fixed award. If a job is not completed in its due time, the penalty, which is subtracted from the award, increases linearly with time. Job details are outlined in Table 1.

J1 are shorter jobs with a minor award. J2 are lengthier and carry a significantly greater award. As such, they implicitly have a higher priority.

1  
2  
3 The goal of control is to maximize the reward. In this case, a genetic algorithm  
4 approach is chosen for the control algorithm for several reasons. Firstly, the problem  
5 is non-deterministic, because the arrival times are generated randomly. It is more  
6 important for the algorithm to find a good solution in a short period of time than for it  
7 to find the optimal solution, as the optimum may change with every new job arrival  
8 anyway. Secondly, modifying the parameters of the genetic algorithm allows us to test  
9 the changes in control algorithms. The complexity measure can then be evaluated  
10 with regards to the algorithm parameters. Lastly, the specified goal is easily encoded  
11 into a fitness function.  
12  
13  
14  
15  
16  
17  
18  
19  
20  
21  
22  
23

24 For the genetic algorithm, a direct approach with a job-based encoding is used  
25 (Hongze et al., 2009). The crossover is position-based. Swap mutation is used (Cheng  
26 et al., 1996). The genetic algorithm takes the jobs that had not been processed yet and  
27 schedules them to machines. The fitness function of the algorithm maps a schedule  
28 encoding to its calculated received reward. The schedules specify job orders for each  
29 machine. Jobs are processed sequentially with zero in-between time.  
30  
31  
32  
33  
34  
35  
36  
37  
38

39 The simulated control problem is presented in Figure 4.

40  
41 For the analysis, inputs, states, and outputs are observed at different levels and  
42 with different encodings ( $O_x$ ,  $O_s$ , and  $O_y$  respectively). The observations are made on  
43 each step of the simulation.  
44  
45  
46  
47

48 Inputs are encoded using the job type. The encoding process is as follows. If  
49 no job arrives, the inputs are encoded to be "0". Inputs are encoded to be "1" and "2"  
50 when jobs of type J1 and J2 arrive, respectively. If jobs of both types arrive on the  
51 same simulation step, the inputs are encoded to be "3".  
52  
53  
54  
55  
56

57 Similarly, the states are encoded in three different ways. "Full states" by using  
58 machine ID and job type, "states" by using machine ID and whether the machine is  
59  
60

1  
2  
3 processing a job or is idle, and “trivial states” by observing whether any of the  
4  
5 machines is processing a job or not.  
6  
7

8 The outputs are encoded in two different ways: “outputs” by using the job type  
9  
10 and “trivial outputs” by only considering whether something was produced or not.  
11

12 Three groups of experiments are carried out. In each case, the experiment ends  
13  
14 after 1000000 simulation steps and is repeated 10 times. Statistical complexity is  
15  
16 evaluated using the CSSR algorithm.  
17  
18

#### 19 20 21 ***4.2 Standard Configuration with Different Algorithm Properties*** 22

23 In this group of experiments, the effects of the control algorithm on complexity are  
24  
25 analyzed. In order to do this, genetic algorithm scheduling is compared to random  
26  
27 scheduling. In the genetic algorithm case, population size is set to 20, mutation rate is  
28  
29 set to 0.05, and the number of generations is fixed at 5. In the case of random  
30  
31 scheduling, schedules are generated randomly. Both algorithms produce a new  
32  
33 schedule when a new job arrives.  
34  
35  
36

37 Results are shown in Table 2.  
38

39 The complexity of randomly generated inputs, encoded in the same way as  
40  
41 outputs, was calculated to be 0 in both cases. The result is trivial, but confirms  
42  
43 complete randomness is adequately recognized by the calculation method.  
44  
45  
46

47 Although the inputs are random and thus easy to predict, the outputs are not,  
48  
49 even in the case of random scheduling. This shows that some inherent structure is  
50  
51 present in the system.  
52  
53

54 In the presented scenario, output patterns are a consequence of rules implicitly  
55  
56 formed by the system and job configuration. In the example, two outputs from the  
57  
58 same machine cannot be fewer than 12 simulation steps apart, because 12 is the  
59  
60



1  
2  
3 processing time for the shortest possible job. Rules like this limit the possible output  
4 sequences and are the reason behind the observed output pattern.  
5  
6

7  
8 When the genetic algorithm is introduced, the complexity of outputs and states  
9 decreases. In other words, they become easier to predict. This is in agreement with the  
10 intuitive notion that control increases the predictability of the outputs and decreases  
11 the effort needed to make the prediction.  
12  
13

14  
15 An interesting result is that when the states are observed on the “trivial states”  
16 level, the complexity increases when control is introduced. Both configurations  
17 produce the same automaton configuration, depicted in Figure 5.  
18  
19

20  
21 The difference is that when random scheduling is used, the probability of the  
22 system being in state 1 (idle) decreases and the probability of state 14 (continuous  
23 work) increases. Higher probability of state 14 decreases the uncertainty of the  
24 automaton state, subsequently giving lower complexity.  
25  
26

27  
28 Figure 5 also clearly shows the pattern discovered by the method. The left part  
29 of the automaton represents processing of a single J1 job. Processing of J2 jobs takes  
30 place in state 14 – continuous work.  
31  
32

33  
34 The case of trivial state encoding also shows that by choosing a level of  
35 observation that is too coarse, the complexity is not captured adequately. Efficiencies  
36 of prediction, presented in Table 2, show that prediction is significantly less efficient  
37 on the trivial states level. Consequently, this level is less suitable for observation, as it  
38 gives rise to no new emergent patterns, which would result in higher efficiency of  
39 prediction.  
40  
41

42  
43 The contribution of this set of experiments is twofold. Firstly, controlling  
44 regularities by means of a control algorithm can be used to manage the complexity. In  
45 the case presented, outputs and states become easier to predict. Secondly, however,  
46  
47  
48  
49  
50  
51  
52  
53  
54  
55  
56  
57  
58  
59  
60

1  
2  
3 this has to be observed on an appropriate level, as a coarse-grained projection of the  
4 observation can have different complexity properties. Efficiency of prediction can be  
5 used to guide the observation level selection.  
6  
7  
8  
9

### 10 11 **4.3 Configuration with Three Machines**

12 This group of experiments is designed to test how the system structure influences  
13 operational complexity. Two more scenarios are devised in addition to the original  
14 one with two machines (2M). The second scenario (3ME) uses three machines, while  
15 inputs remain the same as in the 2M scenario. In the third scenario (3MH), three  
16 machines are used as well. The average job inter-arrival times are modified, so that  
17 jobs arrive proportionally more frequently for three machines as they do for two. The  
18 scenarios are compared in Figure 6.  
19  
20  
21  
22  
23  
24  
25  
26  
27  
28

29 The results show that output complexity is mainly influenced by input job  
30 configuration, regardless of encoding. In 2M and 3ME cases, in which input job  
31 configuration is the same, output complexity does not differ significantly. In the 3MH  
32 case, where more jobs arrive per time unit, the output complexity rises.  
33  
34  
35  
36  
37  
38

39 The state complexity, on the other hand, is mostly influenced by the number of  
40 machines. This is understandable, as more machines yield a bigger state space.  
41  
42

43 The trivial states level again behaves differently from the states and full states  
44 levels. As in the previous case, the automaton is the same in all three scenarios  
45 (Figure 5). The complexity increases in the 3ME case because the probability of being  
46 idle increases, and drops in the 3MH case because the probability drops. This is a  
47 consequence of the fact that there is a greater probability that at least one machine is  
48 processing a job at all times in the 3MH case.  
49  
50  
51  
52  
53  
54  
55  
56

57 Another interpretation is provided by the complexity curves in Figure 6 b).  
58 The inputs exhibit complexity of zero in all cases. As they transform into states, the  
59  
60

1  
2  
3 complexity rises depending on the system structure. The output complexity is then  
4  
5  
6 mainly determined by the input configuration.  
7

8 This group of experiments suggests that complexity should be studied by  
9  
10 simultaneously observing the system at different levels. Aspects of how operational  
11  
12 complexity is influenced by structural complexity can, for example, be quantified by  
13  
14 observing the system states. Properties of the inputs, conversely, can be quantified by  
15  
16 observing the outputs. The complete view on operational complexity can only be  
17  
18 obtained by observing both.  
19  
20  
21

#### 22 23 ***4.4 Configuration with Periodic Control***

24 The main question for this group of experiments is whether complexity can be  
25  
26 decreased by introducing periodicity into the control algorithm, as hypothesized by  
27  
28 Suh (2005).  
29  
30

31 Periodic control was simulated by running the genetic algorithm periodically.  
32  
33 Four experiments were carried out with periods of one (every step), two, four, and  
34  
35 eight steps. The algorithm processes all pending jobs only at the beginning of each  
36  
37 period.  
38  
39  
40

41 The results in Figure 7 show that output complexity does decrease, but does  
42  
43 not do so significantly. In relation to the previous group of experiments, this is  
44  
45 speculated to be a consequence of the fact that output operational complexity is  
46  
47 mostly influenced by input configuration.  
48  
49

50 Conversely, the state complexity does decrease significantly, but only to a  
51  
52 certain point. The decrease of complexity is a consequence of the fact that jobs are  
53  
54 packed one after another more closely. This results in longer periods of continuous  
55  
56 work followed by longer periods of the system being idle. The future states  
57  
58 consequently become easier to predict.  
59  
60

1  
2  
3 Periodic control is hereby shown to lower the operational complexity of  
4  
5 system states. As such, it can be used as a countermeasure to the growth of  
6  
7 complexity due to structure, which was shown in the previous Subsection.  
8  
9

## 10 11 **5 Case Study**

12 The practicality of the approach is shown in a case study based on real data acquired  
13  
14 from a manufacturing company. The production is serial, running 24 hours a day in  
15  
16 three shifts.  
17  
18

19  
20 Data was acquired for five manufacturing centres over a period of 24 months,  
21  
22 from October 2007 to October 2009. The data consists of times, at which the outputs  
23  
24 were produced, along with several process parameters. In the case study, the  
25  
26 productivity data is analyzed to assess the complexity of the outputs.  
27  
28

29  
30 The method of encoding the data is adopted from (Nerukh et al., 2002).  
31  
32 Firstly, the number of pieces produced per hour is calculated for the whole period.  
33  
34 Quantities are encoded with bins of size 20. This means that for zero produced pieces,  
35  
36 the value is set to 0, for 1–20, the value is set to 1, etc. The complexity for each month  
37  
38 is calculated using a three month window in order to achieve the required data length.  
39  
40 CSSR algorithm is used to reconstruct the automata. The length of the analyzed  
41  
42 string is 16.  
43  
44

### 45 46 47 **5.1 Results and Discussion**

48 Figure 8 shows complexity and production rate for the period between November  
49  
50 2007 and August 2009.  
51

52  
53 The operational complexity of outputs remains high, at approximately 11 bits,  
54  
55 throughout 2008. In December 2008 and January 2009, no pieces were produced for a  
56  
57 period of three weeks as a consequence of the holiday season. The complexity,  
58  
59 accordingly, sharply drops to less than 3 bits in this period.  
60

1  
2  
3 In 2009, complexity increases again but never reaches the heights of 2008 and  
4 fluctuates around approximately 9 bits. This remains true even in July 2009, when  
5  
6  
7  
8 slightly more pieces were produced than in August 2008 (marked on Figure 8).  
9

10  
11 In light of the findings of simulation studies, lower output complexity in 2009  
12 is a direct consequence of lower demand, which is itself a consequence of the global  
13 recession. Lower demand also influences the complexity indirectly. In 2009, the  
14  
15  
16  
17  
18  
19  
20  
21  
22  
23  
24 management introduced free weekends in order to cope with the situation. Thusly,  
25  
26  
27  
28  
29  
30  
31  
32  
33  
34  
35  
36  
37  
38  
39  
40  
41  
42  
43  
44  
45  
46  
47  
48  
49  
50  
51  
52  
53  
54  
55  
56  
57  
58  
59  
60  
61  
62  
63  
64  
65  
66  
67  
68  
69  
70  
71  
72  
73  
74  
75  
76  
77  
78  
79  
80  
81  
82  
83  
84  
85  
86  
87  
88  
89  
90  
91  
92  
93  
94  
95  
96  
97  
98  
99  
100  
101  
102  
103  
104  
105  
106  
107  
108  
109  
110  
111  
112  
113  
114  
115  
116  
117  
118  
119  
120  
121  
122  
123  
124  
125  
126  
127  
128  
129  
130  
131  
132  
133  
134  
135  
136  
137  
138  
139  
140  
141  
142  
143  
144  
145  
146  
147  
148  
149  
150  
151  
152  
153  
154  
155  
156  
157  
158  
159  
160  
161  
162  
163  
164  
165  
166  
167  
168  
169  
170  
171  
172  
173  
174  
175  
176  
177  
178  
179  
180  
181  
182  
183  
184  
185  
186  
187  
188  
189  
190  
191  
192  
193  
194  
195  
196  
197  
198  
199  
200  
201  
202  
203  
204  
205  
206  
207  
208  
209  
210  
211  
212  
213  
214  
215  
216  
217  
218  
219  
220  
221  
222  
223  
224  
225  
226  
227  
228  
229  
230  
231  
232  
233  
234  
235  
236  
237  
238  
239  
240  
241  
242  
243  
244  
245  
246  
247  
248  
249  
250  
251  
252  
253  
254  
255  
256  
257  
258  
259  
260  
261  
262  
263  
264  
265  
266  
267  
268  
269  
270  
271  
272  
273  
274  
275  
276  
277  
278  
279  
280  
281  
282  
283  
284  
285  
286  
287  
288  
289  
290  
291  
292  
293  
294  
295  
296  
297  
298  
299  
300  
301  
302  
303  
304  
305  
306  
307  
308  
309  
310  
311  
312  
313  
314  
315  
316  
317  
318  
319  
320  
321  
322  
323  
324  
325  
326  
327  
328  
329  
330  
331  
332  
333  
334  
335  
336  
337  
338  
339  
340  
341  
342  
343  
344  
345  
346  
347  
348  
349  
350  
351  
352  
353  
354  
355  
356  
357  
358  
359  
360  
361  
362  
363  
364  
365  
366  
367  
368  
369  
370  
371  
372  
373  
374  
375  
376  
377  
378  
379  
380  
381  
382  
383  
384  
385  
386  
387  
388  
389  
390  
391  
392  
393  
394  
395  
396  
397  
398  
399  
400  
401  
402  
403  
404  
405  
406  
407  
408  
409  
410  
411  
412  
413  
414  
415  
416  
417  
418  
419  
420  
421  
422  
423  
424  
425  
426  
427  
428  
429  
430  
431  
432  
433  
434  
435  
436  
437  
438  
439  
440  
441  
442  
443  
444  
445  
446  
447  
448  
449  
450  
451  
452  
453  
454  
455  
456  
457  
458  
459  
460  
461  
462  
463  
464  
465  
466  
467  
468  
469  
470  
471  
472  
473  
474  
475  
476  
477  
478  
479  
480  
481  
482  
483  
484  
485  
486  
487  
488  
489  
490  
491  
492  
493  
494  
495  
496  
497  
498  
499  
500  
501  
502  
503  
504  
505  
506  
507  
508  
509  
510  
511  
512  
513  
514  
515  
516  
517  
518  
519  
520  
521  
522  
523  
524  
525  
526  
527  
528  
529  
530  
531  
532  
533  
534  
535  
536  
537  
538  
539  
540  
541  
542  
543  
544  
545  
546  
547  
548  
549  
550  
551  
552  
553  
554  
555  
556  
557  
558  
559  
560  
561  
562  
563  
564  
565  
566  
567  
568  
569  
570  
571  
572  
573  
574  
575  
576  
577  
578  
579  
580  
581  
582  
583  
584  
585  
586  
587  
588  
589  
590  
591  
592  
593  
594  
595  
596  
597  
598  
599  
600  
601  
602  
603  
604  
605  
606  
607  
608  
609  
610  
611  
612  
613  
614  
615  
616  
617  
618  
619  
620  
621  
622  
623  
624  
625  
626  
627  
628  
629  
630  
631  
632  
633  
634  
635  
636  
637  
638  
639  
640  
641  
642  
643  
644  
645  
646  
647  
648  
649  
650  
651  
652  
653  
654  
655  
656  
657  
658  
659  
660  
661  
662  
663  
664  
665  
666  
667  
668  
669  
670  
671  
672  
673  
674  
675  
676  
677  
678  
679  
680  
681  
682  
683  
684  
685  
686  
687  
688  
689  
690  
691  
692  
693  
694  
695  
696  
697  
698  
699  
700  
701  
702  
703  
704  
705  
706  
707  
708  
709  
710  
711  
712  
713  
714  
715  
716  
717  
718  
719  
720  
721  
722  
723  
724  
725  
726  
727  
728  
729  
730  
731  
732  
733  
734  
735  
736  
737  
738  
739  
740  
741  
742  
743  
744  
745  
746  
747  
748  
749  
750  
751  
752  
753  
754  
755  
756  
757  
758  
759  
760  
761  
762  
763  
764  
765  
766  
767  
768  
769  
770  
771  
772  
773  
774  
775  
776  
777  
778  
779  
780  
781  
782  
783  
784  
785  
786  
787  
788  
789  
790  
791  
792  
793  
794  
795  
796  
797  
798  
799  
800  
801  
802  
803  
804  
805  
806  
807  
808  
809  
810  
811  
812  
813  
814  
815  
816  
817  
818  
819  
820  
821  
822  
823  
824  
825  
826  
827  
828  
829  
830  
831  
832  
833  
834  
835  
836  
837  
838  
839  
840  
841  
842  
843  
844  
845  
846  
847  
848  
849  
850  
851  
852  
853  
854  
855  
856  
857  
858  
859  
860  
861  
862  
863  
864  
865  
866  
867  
868  
869  
870  
871  
872  
873  
874  
875  
876  
877  
878  
879  
880  
881  
882  
883  
884  
885  
886  
887  
888  
889  
890  
891  
892  
893  
894  
895  
896  
897  
898  
899  
900  
901  
902  
903  
904  
905  
906  
907  
908  
909  
910  
911  
912  
913  
914  
915  
916  
917  
918  
919  
920  
921  
922  
923  
924  
925  
926  
927  
928  
929  
930  
931  
932  
933  
934  
935  
936  
937  
938  
939  
940  
941  
942  
943  
944  
945  
946  
947  
948  
949  
950  
951  
952  
953  
954  
955  
956  
957  
958  
959  
960  
961  
962  
963  
964  
965  
966  
967  
968  
969  
970  
971  
972  
973  
974  
975  
976  
977  
978  
979  
980  
981  
982  
983  
984  
985  
986  
987  
988  
989  
990  
991  
992  
993  
994  
995  
996  
997  
998  
999  
1000

The results make it clear that there is an intrinsic connection between

complexity and the production rate. In most cases, an increased production rate means a higher complexity as well. Some deviations from this occur in July and August 2008 and July and August 2009. In August, the production rate drops each year because of vacations. Complexity, interestingly, remains the same in both years.

## 6 Conclusions

Complexity has been identified as a ubiquitous property of manufacturing systems, one that has to be embraced by complex systems thinking rather than dismissed. It has been hypothesized that our understanding of complexity must be expanded, and that it can be expanded through the development of complexity metrics.

This paper presents a unique view on operational complexity in manufacturing control. Complexity is associated with the difficulty of prediction. Statistical complexity from computational mechanics is proposed as a complexity metric. The metric offers a practical approach to complexity assessment based on a strong information theory background. As such, it allows for an easy implementation and a clear interpretation.

1  
2  
3 The properties of the metric are explored in the manufacturing context using  
4 simulation studies which highlight the limitations associated with the choice of the  
5 observation level. The metric is found to be both subjective and objective. It is  
6 determined by the subjective choice of the observation level, but is calculated  
7 deterministically based on the observed time series. This allows for a comparison of  
8 different systems when they are observed at the same level.

9  
10 Several implications of the choice of the observation level are outlined. It is  
11 suggested complexity should be studied by simultaneously observing the system at  
12 different levels. A complete picture of complexity can therefore only be obtained by  
13 merging the partial views of different management levels. Efficiency of prediction can  
14 be used as a metric that guides the selection of observation levels.

15  
16 Introduction of periodicity into control is shown to lower the complexity of  
17 manufacturing plant states and is suggested to be used as a countermeasure to the  
18 growth of complexity due to growth of structure, e.g. with the introduction of new  
19 machines.

20  
21 Practicality of the approach is confirmed by the case study, wherein the  
22 operational complexity of outputs is calculated for real data obtained from serial  
23 production. The case study uses an established method to encode the data. The results  
24 show a drop in complexity as a consequence of the drop in demand in 2009, which  
25 was a reaction to the global recession. This supports the hypothesis that complexity  
26 should not be decreased regardless of the cost, but should instead be properly  
27 managed.

28  
29 Although the case study gives some insight into complexity, further studies are  
30 needed to build a causal relation between complexity and the events that influence it.  
31 Only then could the root causes to specific problems be identified using the proposed

1  
2  
3 metric. Future work will focus on exploring the relations between product complexity,  
4 process complexity, and manufacturing system configurations complexity in regards  
5 to the operational complexity. Other possibilities for future work include development  
6 of a general method for assessing complexity in manufacturing systems and a further  
7 exploration of the impacts of the levels of observation.  
8  
9  
10  
11  
12  
13  
14

## 15 16 **References**

17 Baker, A.D., 1998. A Survey of Factory Control Algorithms that can be Implemented  
18 in a Multi-agent Heterarchy: Dispatching, Scheduling, and Pull. *Journal of*  
19 *Manufacturing Systems*, 17 (4), 297-320.  
20  
21  
22  
23

24  
25  
26  
27 Buchanan, M., 2004. Power Laws & the New Science of Complexity Management.  
28 *strategy+business*, Spring 2004 (34).  
29  
30  
31

32  
33  
34 Cheng, R., Gen, M. and Tsujimura, Y., 1996. A Tutorial Survey of Job-shop  
35 Scheduling Problems Using Genetic Algorithms, Part I: Representation. *Computers &*  
36 *Industrial Engineering*, 30 (4), 983-997.  
37  
38  
39  
40

41  
42  
43 Efstathiou, J., Calinescu, A. and Blackburn, G., 2002. A Web-based Expert System to  
44 Assess the Complexity of Manufacturing Organizations. *Robotics and Computer-*  
45 *Integrated Manufacturing*, 18 (3-4), 305-311.  
46  
47  
48  
49

50  
51  
52  
53 ElMaraghy, H., Kuzgunkaya, O. and Urbanic, R., 2005. Manufacturing Systems  
54 Configuration Complexity. *CIRP Annals - Manufacturing Technology*, 54 (1), 445-  
55 450.  
56  
57  
58  
59  
60

- 1  
2  
3 Frizelle, G. and Suhov, Y.M., 2001. An Entropic Measurement of Queueing  
4 Behaviour in a Class of Manufacturing Operations. *Proceedings: Mathematical,*  
5  
6 *Physical and Engineering Sciences*, 457 (2011), 1579-1601.  
7  
8  
9  
10  
11  
12 Frizelle, G. and Woodcock, E., 1995. Measuring Complexity as an Aid to Developing  
13 Operational Strategy. *International Journal of Operations & Production*  
14 *Management*, 15 (5), 26-39.  
15  
16  
17  
18  
19  
20  
21  
22 Hon, K., 2005. Performance and Evaluation of Manufacturing Systems. *CIRP Annals*  
23 *- Manufacturing Technology*, 54 (2), 139-154.  
24  
25  
26  
27  
28  
29 Hongze, Q., Wanli, Z. and Hailong, W., 2009. A Genetic Algorithm-Based Approach  
30 to Flexible Job-Shop Scheduling Problem. *Proceedings: ICNC '09*, 81-85.  
31  
32  
33  
34  
35  
36 Hu, S., Zhu, X., Wang, H., Koren, Y., 2008. Product Variety and Manufacturing  
37 Complexity in Assembly Systems and Supply Chains. *CIRP Annals - Manufacturing*  
38 *Technology*, 57 (1), 45-48.  
39  
40  
41  
42  
43  
44  
45  
46 Huaccho Huatuco, L., Efstathiou, J., Calinescu, A., Sivadasan, S. and Kariuki, S.,  
47  
48 2009. Comparing the impact of different rescheduling strategies on the entropic-  
49 related complexity of manufacturing systems. *International Journal of Production*  
50 *Research*, 47 (15), 4305-4325.  
51  
52  
53  
54  
55  
56  
57 Isik, F., 2010. An entropy-based approach for measuring complexity in supply chains.  
58 *International Journal of Production Research*, 48 (12), 3681-3696.  
59  
60



1  
2  
3 Jenab, K., Liu, D., 2010. A graph-based model for manufacturing complexity.  
4  
5  
6 *International Journal of Production Research*, 48 (11), 3383-3392.  
7  
8  
9

10 Melnyk, S.A., Stewart, D.M. and Swink, M., 2004. Metrics and Performance  
11  
12 Measurement in Operations Management: Dealing with the Metrics Maze. *Journal of*  
13  
14 *Operations Management*, 22 (3), 209-218.  
15  
16  
17

18  
19 Nerukh, D., Karvounis, G. and Glen, R.C., 2002. Complexity of Classical Dynamics  
20  
21 of Molecular Systems. I. Methodology. *J. Chem. Phys.*, 117 (21), 9611-9617.  
22  
23  
24

25  
26  
27 Park, J.B., Lee, J.W., Yang, J., Jo, H. and Moon, H., 2006. Complexity Analysis of  
28  
29 the Stock Market. *Physica A*, 379 (1), 179-187.  
30  
31  
32

33  
34 Peklenik, J., 1988. Fertigungskybernetik, Eine neue wissenschaftliche Disziplin für  
35  
36 die Produktionstechnik. *Festvortrag anlässlich der Verleihung des Georg-Schlesinger*  
37  
38 *Preises 1988 des Landes Berlin*.  
39  
40  
41

42  
43 Peklenik, J., 1995. Complexity in Manufacturing Systems. *CIRP Journal of*  
44  
45 *Manufacturing Systems*, 24 (1), 17-25.  
46  
47  
48

49  
50 Prokopenko, M., Boschetti, F. and Ryan, A.J., 2009. An Information-theoretic Primer  
51  
52 on Complexity, Self-organization, and Emergence. *Complexity*, 15 (1), 11-28.  
53  
54  
55

1  
2  
3 Shafiei-Monafred, S., Jenab, K., 2010. Complexity analysis of an operation in  
4 demand-based manufacturing. *International Journal of Production Research*, First  
5  
6 published on: 21 December 2010 (iFirst).  
7  
8  
9

10  
11  
12 Shalizi, C.R., 2001. Causal Architecture, Complexity and Self-organization in Time  
13 Series and Cellular Automata. Thesis (PhD), University of Michigan.  
14

15  
16  
17 Shalizi, C.R. and Crutchfield, J.P., 2001. Computational Mechanics: Pattern and  
18 Prediction, Structure and Simplicity. *Journal of Statistical Physics*, 104 (3-4), 817-  
19  
20  
21  
22  
23  
24  
25  
26  
27  
28  
29  
30  
31  
32  
33  
34  
35  
36  
37  
38  
39  
40  
41  
42  
43  
44  
45  
46  
47  
48  
49  
50  
51  
52  
53  
54  
55  
56  
57  
58  
59  
60

Shalizi, C.R. and Moore, C., 2003. What Is a Macrostate? Subjective Observations  
and Objective Dynamics. *arXiv*, cond-mat/0303625.

Shalizi, C.R. and Shalizi, K.L., 2004. Blind Construction of Optimal Nonlinear  
Recursive Predictors for Discrete Sequences. *Proceedings of UAI 2004*, 504-511.

Shannon, C., 1948. A Mathematical Theory of Communication. CSLI Publications.

Sivadasan, S., Efstathiou, J., Frizelle, G., Shirazi, R. and Calinescu, A., 2002. An  
Information-theoretic Methodology for Measuring the Operational Complexity of  
Supplier-Customer Systems. *International Journal of Operations & Production  
Management*, 22 (1), 80-102.

Suh, N.P., 2005. Complexity in Engineering. *CIRP Annals - Manufacturing  
Technology*, 54 (2), 46-63.

1  
2  
3  
4  
5  
6 Wiendahl, H. and Scholtissek, P., 1994. Management and Control of Complexity in  
7  
8 Manufacturing. *CIRP Annals - Manufacturing Technology*, 43 (2), 533-540.  
9

10  
11  
12 Wang, H., Hu, S., 2010. Manufacturing Complexity in Assembly Systems with  
13  
14 Hybrid Configurations and its Impact on Throughput. *CIRP Annals - Manufacturing*  
15  
16 *Technology*, 59 (1), 53-56.  
17  
18  
19  
20  
21  
22  
23  
24  
25  
26  
27  
28  
29  
30  
31  
32  
33  
34  
35  
36  
37  
38  
39  
40  
41  
42  
43  
44  
45  
46  
47  
48  
49  
50  
51  
52  
53  
54  
55  
56  
57  
58  
59  
60

1  
2  
3  
4  
5  
6  
7  
8  
9  
10  
11  
12  
13  
14  
15  
16  
17  
18  
19  
20  
21  
22  
23  
24  
25  
26  
27  
28  
29  
30  
31  
32  
33  
34  
35  
36  
37  
38  
39  
40  
41  
42  
43  
44  
45  
46  
47  
48  
49  
50  
51  
52  
53  
54  
55  
56  
57  
58  
59  
60

Job type	Inter-arrival time [steps]	Processing time [steps]	Due time relative to arrival time [steps]	Award	Penalty rate [step <sup>-1</sup> ]
J1	14	12	30	3	1
J2	50	32	40	50	10

Table 1: Job details

For Peer Review Only

CSSR, L=20, average values	$C_{\mu, \text{input}}$ [bits]	$C_{\mu, \text{output}}$ [bits]	$C_{\mu, \text{state}}$ [bits]	$C_{\mu, \text{trivial state}}$ [bits]
Random	0	7.68	8.14	0.93
Genetic algorithm	0	7.07	7.44	1.39
Efficiency of prediction on the observation level	0 %	96.2 %	97.3 %	68.4 %

Table 2: Comparison of random and genetic algorithm scheduling from the perspective of statistical complexity

For Peer Review Only

1  
2  
3 Figure 1: Manufacturing cybernetics view on the manufacturing control problem.  
4

5 Figure 2: The complexity curve from the control problem perspective.  
6  
7

8 Figure 3:  $\epsilon$ -machines for a completely random process, a deterministic process, and  
9 the same deterministic process, but with a different encoding.  
10

11 Figure 4: The simulated problem postulated as a control problem.  
12

13 Figure 5:  $\epsilon$ -machine for trivial states – genetic algorithm scheduling.  
14

15  
16 Figure 6: Average statistical complexity of the 2M, 3ME and 3MH configurations,  
17 observed on different levels.  
18

19 Figure 7: Statistical complexity with regards to control period.  
20  
21

22 Figure 8: Statistical complexity and productivity of the analysed data.  
23  
24  
25  
26  
27  
28  
29  
30  
31  
32  
33  
34  
35  
36  
37  
38  
39  
40  
41  
42  
43  
44  
45  
46  
47  
48  
49  
50  
51  
52  
53  
54  
55  
56  
57  
58  
59  
60

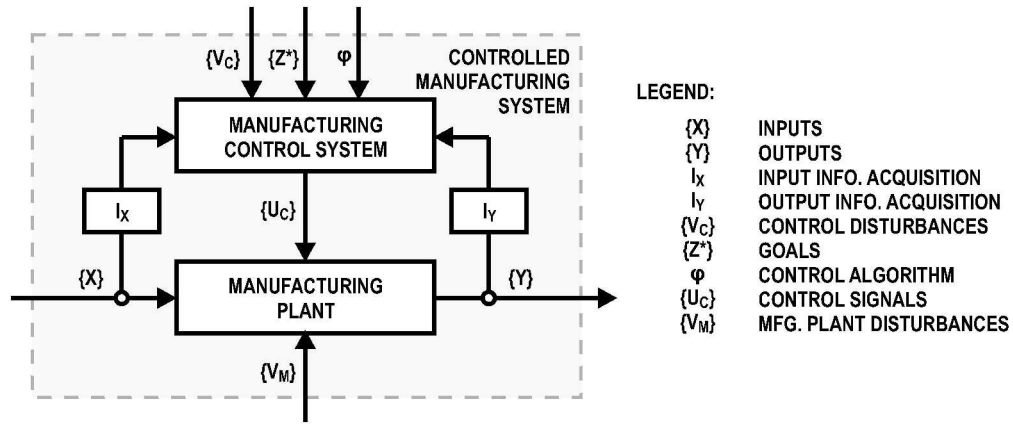

Manufacturing cybernetics view on the manufacturing control problem.  
132x55mm (600 x 600 DPI)

Peer Review Only

1  
2  
3  
4  
5  
6  
7  
8  
9  
10  
11  
12  
13  
14  
15  
16  
17  
18  
19  
20  
21  
22  
23  
24  
25  
26  
27  
28  
29  
30  
31  
32  
33  
34  
35  
36  
37  
38  
39  
40  
41  
42  
43  
44  
45  
46  
47  
48  
49  
50  
51  
52  
53  
54  
55  
56  
57  
58  
59  
60

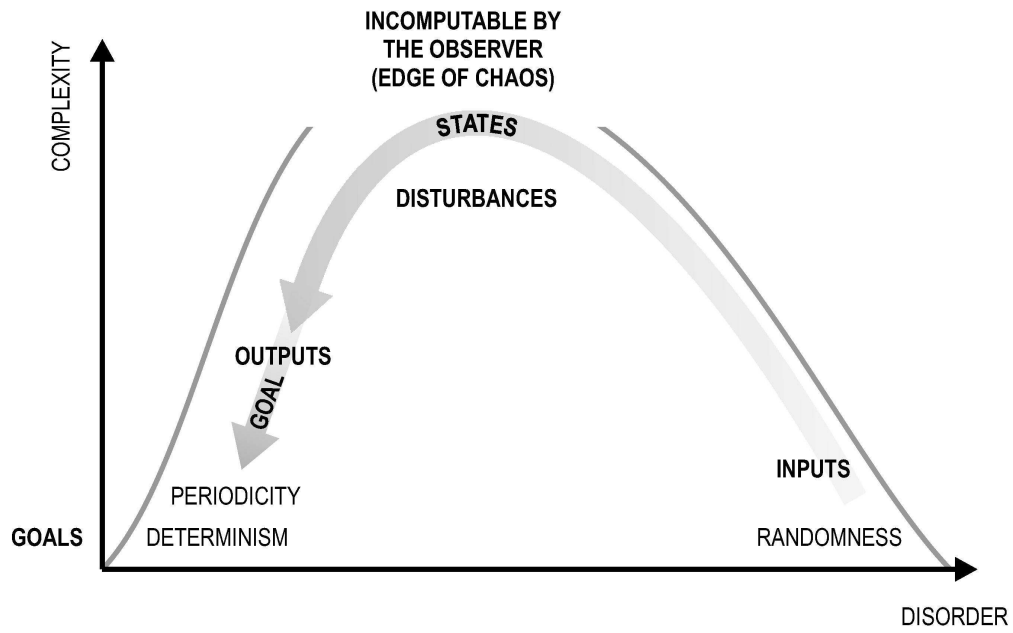

The complexity curve from the control problem perspective.  
113x70mm (600 x 600 DPI)

Review Only



TYPE	$\epsilon$ -MACHINE	PRODUCED SEQUENCE	STATISTICAL COMPLEXITY
A) RANDOM		0101100110110111...	0
B) DETERMINISTIC		0101010101010101...	1
C) DETERMINISTIC, DIFFERENT ENCODING		0101010101010101...	0

$\epsilon$ -machines for a completely random process, a deterministic process, and the same deterministic process, but with a different encoding.  
135x59mm (600 x 600 DPI)

1  
2  
3  
4  
5  
6  
7  
8  
9  
10  
11  
12  
13  
14  
15  
16  
17  
18  
19  
20  
21  
22  
23  
24  
25  
26  
27  
28  
29  
30  
31  
32  
33  
34  
35  
36  
37  
38  
39  
40  
41  
42  
43  
44  
45  
46  
47  
48  
49  
50  
51  
52  
53  
54  
55  
56  
57  
58  
59  
60

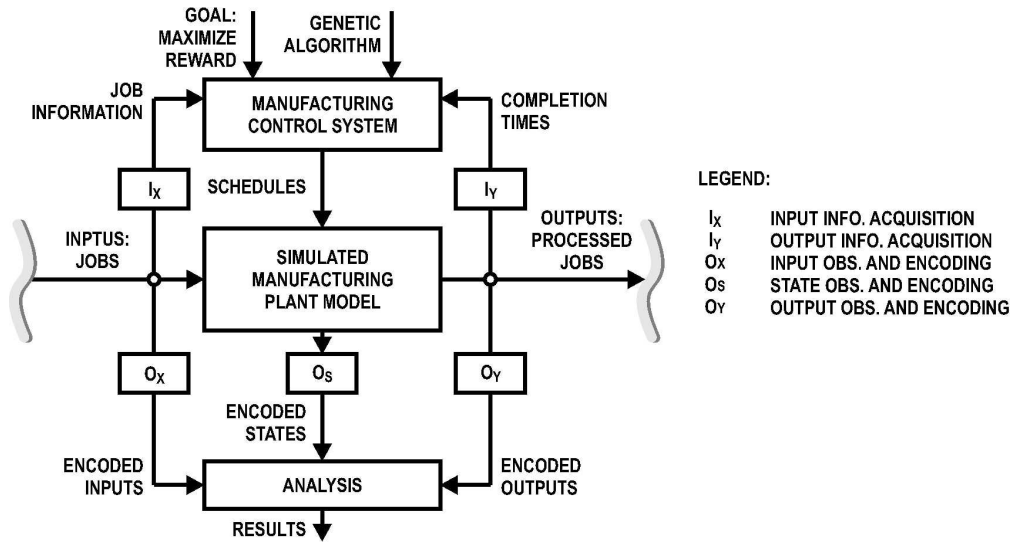

The simulated problem postulated as a control problem.  
144x77mm (600 x 600 DPI)

Review Only

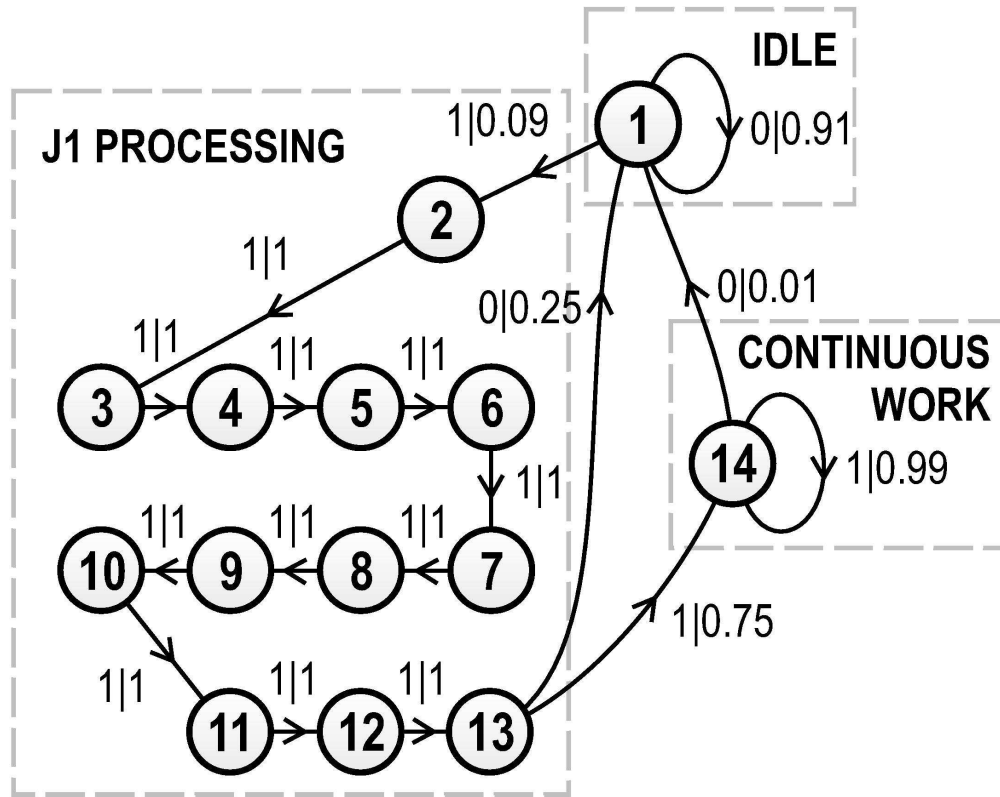

$\epsilon$ -machine for trivial states – genetic algorithm scheduling.  
92x73mm (600 x 600 DPI)

ew Only

1  
2  
3  
4  
5  
6  
7  
8  
9  
10  
11  
12  
13  
14  
15  
16  
17  
18  
19  
20  
21  
22  
23  
24  
25  
26  
27  
28  
29  
30  
31  
32  
33  
34  
35  
36  
37  
38  
39  
40  
41  
42  
43  
44  
45  
46  
47  
48  
49  
50  
51  
52  
53  
54  
55  
56  
57  
58  
59  
60

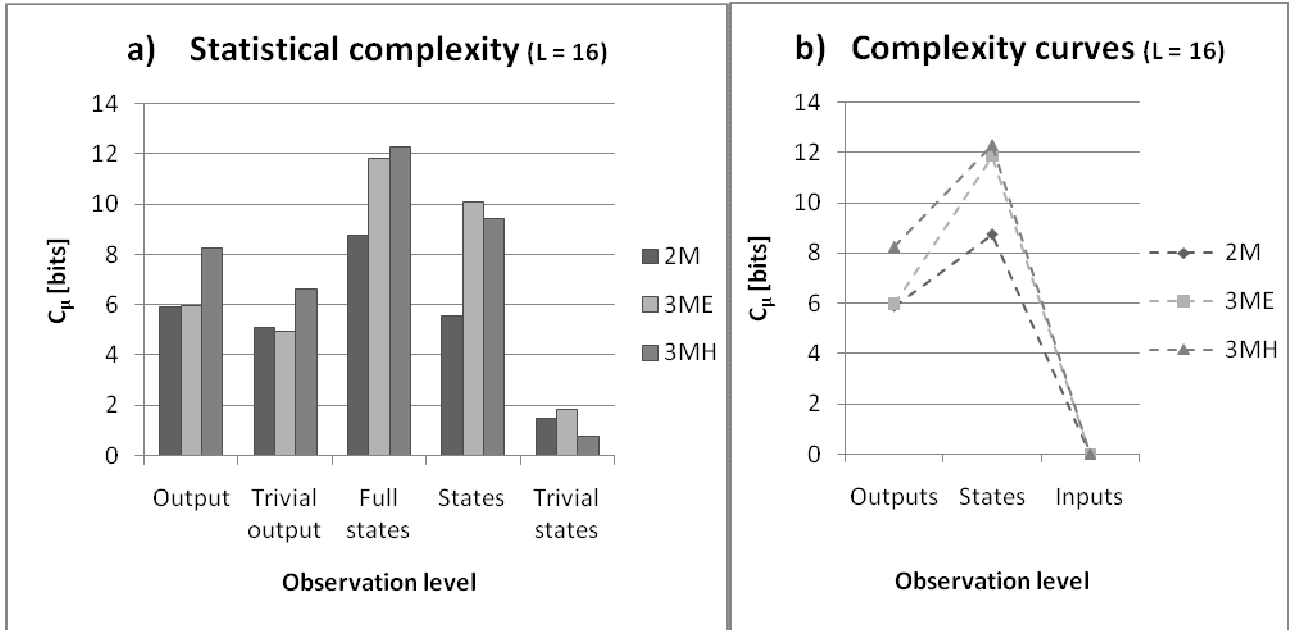

Peer Review Only

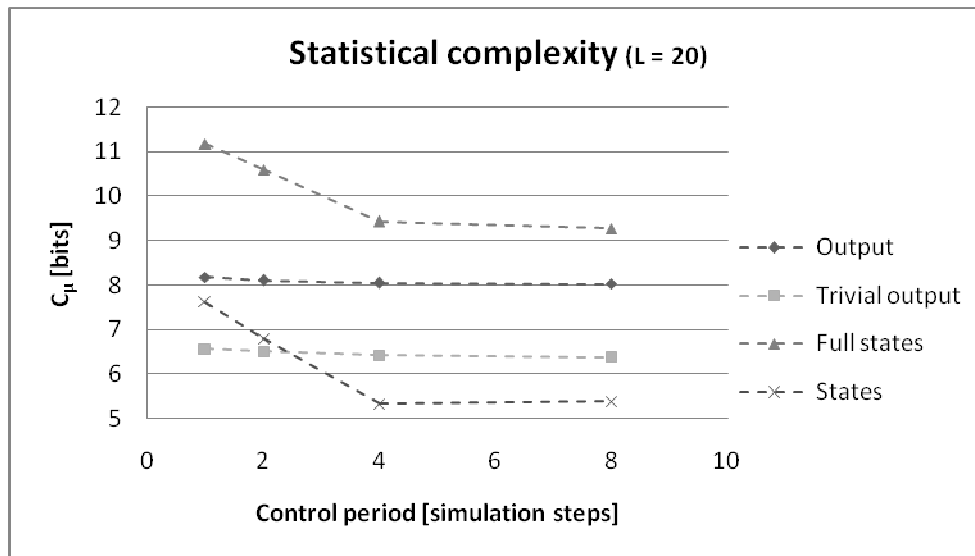

1  
2  
3  
4  
5  
6  
7  
8  
9  
10  
11  
12  
13  
14  
15  
16  
17  
18  
19  
20  
21  
22  
23  
24  
25  
26  
27  
28  
29  
30  
31  
32  
33  
34  
35  
36  
37  
38  
39  
40  
41  
42  
43  
44  
45  
46  
47  
48  
49  
50  
51  
52  
53  
54  
55  
56  
57  
58  
59  
60

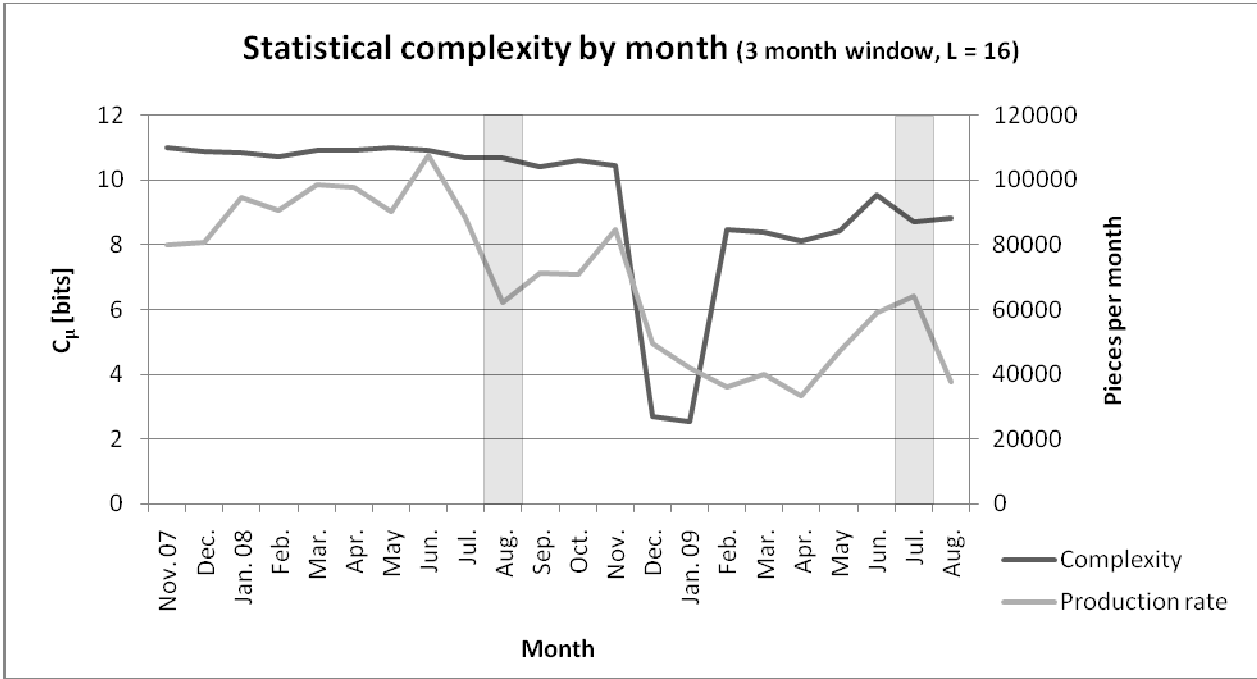

Peer Review Only