



HAL
open science

Carleman estimates for some non smooth anisotropic media

Assia Benabdallah, Yves Dermenjian, Laetitia Thevenet

► **To cite this version:**

Assia Benabdallah, Yves Dermenjian, Laetitia Thevenet. Carleman estimates for some non smooth anisotropic media. 2012. hal-00715108

HAL Id: hal-00715108

<https://hal.science/hal-00715108>

Preprint submitted on 6 Jul 2012

HAL is a multi-disciplinary open access archive for the deposit and dissemination of scientific research documents, whether they are published or not. The documents may come from teaching and research institutions in France or abroad, or from public or private research centers.

L'archive ouverte pluridisciplinaire **HAL**, est destinée au dépôt et à la diffusion de documents scientifiques de niveau recherche, publiés ou non, émanant des établissements d'enseignement et de recherche français ou étrangers, des laboratoires publics ou privés.

Carleman estimates for some non smooth anisotropic media

Assia Benabdallah¹, Yves Dermenjian², Laetitia Thevenet³,
Laboratoire d'Analyse, Topologie, Probabilités^a
CNRS UMR 7353
Aix-Marseille Université, France

June 9, 2012

Abstract

Let B be a $n \times n$ block diagonal matrix in which the first block C_τ is an hermitian matrix of order $(n - 1)$ and the second block c is a positive function. Both are piecewise smooth in $\overline{\Omega}$, a bounded domain of \mathbb{R}^n . If S denotes the set where discontinuities of C_τ and c can occur, we suppose that Ω is stratified in a neighborhood of S in the sense that locally it takes the form $\Omega' \times (-\delta, \delta)$ with $\Omega' \subset \mathbb{R}^{n-1}$, $\delta > 0$ and $S = \Omega' \times \{0\}$. We prove a Carleman estimate for the elliptic operator $A = -\nabla \cdot (B\nabla)$ with an arbitrary observation region. This Carleman estimate is obtained through the introduction of a suitable mesh of the neighborhood of S and an associated approximation of c involving the Carleman large parameters.

AMS 2010 subject classification: 35B37, 35J15, 35J60.

Keywords: anisotropic elliptic operators; approximation; non-smooth coefficients; stratified media; Carleman estimate; observation location.

1 Introduction, notation and main results

Carleman estimates [9] have originally been introduced for uniqueness results for partial differential operators and later generalized (see e.g. [13, Chapter 8], [14, Chapter 28], [23]). They have been successfully used for inverse problems [8] and for the null controllability of linear parabolic equations [20] and the null controllability of classes of semi-linear parabolic equations [3, 11, 12].

For a second-order elliptic operator, say $A = -\Delta_x$, acting in a bounded open set $\Omega \subset \mathbb{R}^n$, (local) Carleman estimates take the form

$$s^3 \lambda^4 \|\varphi^{\frac{3}{2}} e^{s\varphi} u\|_{L^2(\Omega)}^2 + s \lambda^2 \|\varphi^{\frac{1}{2}} e^{s\varphi} \nabla_x u\|_{L^2(\Omega)}^2 \leq C \|e^{s\varphi} Au\|_{L^2(\Omega)}^2, \quad u \in \mathcal{C}_c^\infty(\Omega), \quad s \geq s_0, \quad \lambda \geq \lambda_0, \quad (1.1)$$

for a properly chosen weight function β such that $|\beta'| \neq 0$, $\varphi(x) = e^{\lambda\beta(x)}$ and s_0, λ_0, C sufficiently large (see [12]). Difficulties arise if one attempts to derive Carleman estimates in the case of non-smooth coefficients in the principal part of the operator, by example for a regularity lower than

¹assia@cmi.univ-mrs.fr, ²dermenji@cmi.univ-mrs.fr, ³laetitia.thevenet@gmail.com.

L. Thevenet was partially supported by l'Agence Nationale de la Recherche under grant ANR-07-JCJC-0139-01.

^aLATP – 39, rue F. Joliot-Curie, 13453 Marseille cedex 13, France.

Lipschitz. In fact, Carleman estimates imply the unique continuation property which does not hold in general for a $\mathcal{C}^{0,\alpha}$ Hölder regularity of the coefficients with $0 < \alpha < 1$ [21, 22].

Here we are interested in coefficients that are non continuous across an interface S . When the observation takes place in the region where the diffusion coefficient c is the 'lowest', this question was solved in [10] for a parabolic operator $P = \partial_t - \nabla_x \cdot (c(x)\nabla_x)$. In the one dimensional case, and without assumption on the localization of the observation, the question was solved for general piecewise C^1 coefficients [5, 6] and for coefficients with bounded variations [15]. The work [7] generalizes [5, 6] to some stratified media with dimension $n \geq 1$. *Without* Carleman estimate, the controllability for a one dimensional parabolic operator was proved in [2] for $c \in L^\infty$ but this approach does not authorize semilinear operators.

Recently, Carleman estimates for an arbitrary dimension without any condition on the localization of the observation were obtained in [4, 18], in the elliptic case, and in the parabolic case in [7, 19], but the methods used in [4, 16, 17, 18, 19] require strong regularity for the coefficients and for the interface. Moreover, they fall short if the interface crosses the boundary whereas this configuration is typical in bounded stratified media, examples falling into the framework considered here and in [7]. In [7] the authors assumed that the diffusion coefficients have a 'stratified' structure. More precisely, they have considered operators of the form $A = -\nabla \cdot (B(\cdot)\nabla)$ in which the matrix diffusion coefficient $B(x)$ has the following block diagonal form

$$B(x) = B(x', x_n) = \begin{pmatrix} c_1(x_n)C_\tau(x') & 0 \\ 0 & c_2(x_n) \end{pmatrix}$$

where $\Omega = \Omega' \times (-H, H)$, $x = (x', x_n)$, C_τ is a smooth hermitian matrix and the coefficients c_1, c_2 have a possible jump at $x_n = 0$. The object of the present work is to obtain a Carleman estimate for more general diffusion coefficients without a stratified structure that separates variables. We shall consider a matrix diffusion coefficient of the form

$$B(x) = \begin{pmatrix} C_\tau(x) & 0 \\ 0 & c(x) \end{pmatrix}$$

with C_τ and c having possible jump at $x_n = 0$.

Here, to understand the difficulties that we face, the reader can observe that attempting to prove the Carleman estimate by extending the proof as is done in the one dimensional case, leads in fact to tangential terms at the interface S that cannot be controlled. These terms existed also in [10] where B is a scalar function c which led the authors to add conditions on the jump of diffusion coefficient c at the interface. Not to mention our approach, the main contribution of our paper is to derive an estimate of these tangential terms allowing to conclude the proof of the Carleman estimate.

In [7], these tangential terms at the interface are controlled by using Fourier series in the tangential direction. By a suitable choice of the weight function, the low frequencies lead to a positive quadratic form. The treatment of the high frequencies needs more computations. It uses the ideas developed in [4, 18, 19] where the normal part of the elliptic operator can be inverted. In [7] this argument uses the assumption of the separation of the tangential and normal variables in the diffusion matrix B .

In the case we consider here, the diffusion coefficients depend on $x = (x', x_n)$ and, contrary to [7], one cannot decompose the operator A as $\partial_{x_n} c_2(x_n) \partial_{x_n} + A_\tau$ with A_τ a tangential elliptic

operator on Ω' . Our method consists in the introduction of a suitable decomposition, $(\Omega_{j,\delta})$, of a neighborhood of the interface and, on each $\Omega_{j,\delta}$, an approximation of the diffusion coefficient c by a function depending only on the normal variable, x_n , for which the result of [7] can be used. As these approximations depend on the Carleman large parameters s and λ (see (1.1)), we shall need a refined estimate of the tangential derivative (more precisely, for the high frequencies, see Lemma 3.1).

The question of the derivation of Carleman estimates in the case where the diffusion coefficients are *totally* anisotropic in the neighborhood of a point where the interface S meets the boundary $\partial\Omega$ is left open. Note also that deriving Carleman estimates for the parabolic operator associated to the elliptic operator we consider here, is also an open question. In fact, if we follow the same idea as for the elliptic case we present here, and if we use singular weight functions as introduced in [12], we then have to consider approximations of order $\frac{1}{\sqrt{t(T-t)s\lambda\varphi_S}}$ (connected to the Carleman parameters). These approximations blow up near $t = 0$ and $t = T$.

For each pair (s, λ) of Carleman parameters, we introduce several meshes that seem to indicate a connection to numerical methods. We believe that this connection should be further investigated.

1.1 Setting and notation

Let Ω be an open subset in \mathbb{R}^n , with $\Omega = \Omega' \times (-H, H)^1$, where Ω' is a nonempty bounded open subset of \mathbb{R}^{n-1} with \mathcal{C}^2 boundary². We shall use the notation $x = (x', x_n) \in \Omega' \times (-H, H)$. We set $S = \Omega' \times \{0\}$, that will be understood as an interface where coefficients and functions may jump. For a function $f = f(x)$ we define by $[f]_S$ its jump at S , i.e., $[f]_S(x') = f(x)|_{x_n=0^+} - f(x)|_{x_n=0^-}$. For a function u defined on both sides of S , we set $u|_{S^\pm} = (u|_{\Omega^\pm})|_S$, with $\Omega^+ = \Omega' \times (0, H)$ and $\Omega^- = \Omega' \times (-H, 0)$.

Let $B(x)$, $x \in \Omega$, be with values in $M_n(\mathbb{R})$, the space of square matrices with real coefficients of order n . We make the following assumption.

Assumption 1.1. *The matrix diffusion coefficient $B(x', x_n)$ has the following block diagonal form*

$$B(x) = \begin{pmatrix} C_\tau(x) & 0 \\ 0 & c(x) \end{pmatrix}$$

where

1. the functions C_τ, c , are $\mathcal{C}^1(\overline{\Omega^\pm})$ with a possible jump at $x_n = 0$,
2. the two restrictions to the interface S of the function $c : x' \rightarrow c(x', 0^\pm)$ are C^2 ,
3. $C_\tau(x)$ is an hermitian matrix of order $n - 1$.

We further assume uniform ellipticity

$$\begin{aligned} 0 < c_{\min} \leq c(x) \leq c_{\max} < \infty, \quad x \in \Omega, \\ 0 < c_{\min} \text{Id}_{n-1} \leq C_\tau(x) \leq c_{\max} \text{Id}_{n-1}, \quad x \in \Omega. \end{aligned}$$

¹As a matter of fact, we only ask that Ω is a cylinder in a neighborhood of the interface S . See the end of section 2.

²For some particular geometries we can suppose that Ω' is piecewise smooth. Nevertheless the technics used for building our approximation in a neighborhood of the interface seems to require better than \mathcal{C}^1 . We shall take \mathcal{C}^2 for the readability.

We consider the symmetric bilinear H_0^1 -coercive form

$$a(u, v) = \int_{\Omega} (B(\cdot)\nabla u) \cdot \nabla v dx,$$

with domain $D(a) = H_0^1(\Omega)$. It defines a selfadjoint operator $A = -\nabla \cdot (B(\cdot)\nabla)$ in $L^2(\Omega)$ with compact resolvent and its domain is $D(A) = \{u \in H_0^1(\Omega); \nabla \cdot (B(\cdot)\nabla u) \in L^2(\Omega)\}$. In the elliptic case, we shall denote by $\|\cdot\|_{L^2(\Omega)}$ the L^2 norm over Ω and by $|\cdot|_{L^2(S)}$ the L^2 norm over the interface S of codimension 1.

In this article, when the constant C is used, it refers to a constant that is independent of all the parameters. Its value may however change from one line to another. If we want to keep track of the value of a constant we shall use another letter or add a subscript.

1.2 Statements of the main results

We consider ω , a nonempty open subset of Ω . For a function β in $\mathcal{C}^0(\overline{\Omega})$ we set

$$\varphi(x) = e^{\lambda\beta(x)}, \quad \lambda > 0,$$

to be used as weight function. A proper choice of the function β , with respect to the operator A , ω and Ω (see Assumption 2.4 and Assumption 4.1), yields the following Carleman estimate for the elliptic operator A .

Theorem 1.2. *There exist $C > 0$, λ_0 and $s_0 > 0$ such that*

$$\begin{aligned} s\lambda^2 \|e^{s\varphi} \varphi^{\frac{1}{2}} \nabla u\|_{L^2(\Omega)}^2 + s^3 \lambda^4 \|e^{s\varphi} \varphi^{\frac{3}{2}} u\|_{L^2(\Omega)}^2 + s\lambda \left(|e^{s\varphi} \varphi^{\frac{1}{2}} \nabla_{\tau} u|_{L^2(S)}^2 + |e^{s\varphi} \varphi^{\frac{1}{2}} \partial_{x_n} u|_{L^2(S)}^2 \right) \\ + s^3 \lambda^3 |e^{s\varphi} \varphi^{\frac{3}{2}} u|_{L^2(S)}^2 \leq C \left(\|e^{s\varphi} Au\|_{L^2(\Omega)}^2 + s^3 \lambda^4 \|e^{s\varphi} \varphi^{\frac{3}{2}} u\|_{L^2(\omega)}^2 \right), \end{aligned}$$

for all $u \in D(A)$, $\lambda \geq \lambda_0$, and $s \geq s_0$.

Here, ∇_{τ} is the tangential gradient, i.e. parallel to the interface S . Note that the membership of the domain $D(A)$ implies some constraints on the function u at the interface S , namely $u \in H_0^1(\Omega)$ and $B\nabla_x u \in H(\text{div}, \Omega) := \{v \in L^2(\Omega)^n; \text{div } v \in L^2(\Omega)\}$. We shall first prove the result for piecewise C^2 functions satisfying

$$u|_{S^-} = u|_{S^+}, \quad (c\partial_{x_n} u)|_{S^-} = (c\partial_{x_n} u)|_{S^+},$$

and then use their density in $D(A)$ (see Appendix C).

1.3 Outline

Choosing $0 < \delta < H$, our starting point is the following Carleman estimate in the open set $\Omega_{\delta} := \Omega' \times (-\delta, \delta)$.

There exist a weight function β and $C, C' > 0$, $\lambda_0 > 0$, $s_0 > 0$ such that

$$\begin{aligned} C \left(s\lambda^2 \|\varphi^{\frac{1}{2}} e^{s\varphi} \nabla u\|_{L^2(\Omega_{\delta})}^2 + s^3 \lambda^4 \|\varphi^{\frac{3}{2}} e^{s\varphi} u\|_{L^2(\Omega_{\delta})}^2 \right) + s\lambda \int_S [c^2 \beta' |e^{s\varphi} \partial_{x_n} u|^2]_S d\sigma \\ + \int_S |s\lambda \varphi e^{s\varphi} u|_S^2 [c^2 \beta'^3]_S d\sigma - \int_S |e^{s\varphi} \nabla_{\tau} u|^2 \|[\beta' c C_{\tau}]_S\| d\sigma \leq C' \|e^{s\varphi} Au\|_{L^2(\Omega_{\delta})}^2 \quad (1.2) \end{aligned}$$

for all $u \in D(A)$, $\lambda \geq \lambda_0$, $s \geq s_0$ and $\text{supp } u \subset \overline{\Omega'} \times (-\delta, \delta)$.

We have to understand $[\beta' c C_\tau]_S$ as the matrix of jumps of each term of the matrix and $\|[\beta' c C_\tau]_S\|$ is its norm that we can take in $L^\infty(S)$. Such an inequality can be obtained by adapting the derivations in [10] for instance and a suitable choice of the weight function β . Some easy handlings (see [7]) show that only the sign of the term $\int_S |e^{s\varphi} \nabla_\tau u|^2 \|[\beta' c C_\tau]_S\| d\sigma$ arises a problem since we cannot exclude to have a negative quantity. In other words, the main difficulty is to estimate the tangential derivative of u at the interface S .

In Section 2, we introduce a covering $(\Omega'_j)_j$ of a neighborhood of $\overline{\Omega'}$ related to the Carleman's parameters s, λ and precise $(c^j)_j$, the approximation of the diffusion coefficient c . Of course, we build an adapted partition of unity $(\chi_j)_j$ subordinated to $(\Omega'_j)_j$ and we define, for each $x_n \in (-\delta, \delta)$ and each j , the tangential part of A , i.e. $A_\tau(x_n) = -\nabla_\tau \cdot C_\tau(\cdot, x_n) \nabla_\tau$ with $D_j(A_\tau(x_n)) = \{u \in H_0^1(\Omega'_j); \nabla_\tau \cdot (C_\tau(\cdot, x_n) \nabla_\tau u) \in L^2(\Omega'_j)\}$. So, for $u \in D(A)$ that solves $Au = f$ with $f \in L^2(\Omega)$, $u_j := \chi_j u$ will solve

$$\begin{cases} A_\tau(x_n)u_j - c^j(x_n)\partial_{x_n}^2 u_j = f_j + g_j + h_j & \text{on } \Omega_{j,\delta}^\pm = \{x = (x', x_n); x' \in \Omega'_j, 0 < \pm x_n < \delta\}, \\ u_j = 0 & \text{on } \partial\Omega_j, \\ [u_j]_{S_j} = 0 \quad \text{and} \quad [c^j \partial_{x_n} u_j]_{S_j} = [(c^j - c)\partial_{x_n} u_j]_{S_j} := \theta_j \end{cases} \quad (1.3)$$

with

$$S_j = \Omega_j \cap S, \quad f_j = \chi_j f, \quad g_j = (c - c^j)\partial_{x_n}^2 u_j \quad \text{and} \quad h_j = [A_\tau, \chi_j]u + (\partial_{x_n} c)(\partial_{x_n} u_j), \quad (1.4)$$

where $[A_\tau, \chi_j]$ denotes the commutator of A_τ and χ_j .

It will be sufficient to estimate the tangential derivative of u_j defined below. We cannot directly apply the results of [7] for two main reasons:

1. the dependence on x_n of A_τ ,
2. the presence of θ_j and g_j involving the normal derivative of u on S_j and the second derivative of u on Ω_j ,
3. the presence of h_j which depends on s, λ .

To take into account the first constraint, we consider $(\mu_{j,k}^2(x_n))_{k \geq 1}$, the family of eigenvalues of $(A_\tau(x_n), D_j(A_\tau(x_n)))$, and denote by $u_{j,k}, f_{j,k}, g_{j,k}, h_{j,k}$ and $\theta_{j,k}$ the respective Fourier coefficients of u_j, f_j, g_j, h_j and θ_j in an orthonormal basis associated to the previous eigenvalues.

To overcome the two other constraints, we prove a refined estimate of the high frequencies (i.e. coefficients associated to the large eigenvalues in the decomposition on the eigenfunctions) of the tangential derivatives of u_j (see Section 3): there exist a constant C independent of $s, \lambda, \mu_{j,k}$, a constant $\mu_0 := \mu_0(s, \lambda) > 0$ such that, for all $\mu_{j,k}(0^+) \geq \mu_0$, one has

$$s\lambda\varphi_{|S} |\mu_{j,k}(0^+) e^{s\varphi_{|S}} u_{j,k}|_{S_j}^2 \leq C \left(|e^{s\varphi} f_{j,k}|_{L^2(-\delta, \delta)}^2 + \varphi_{|S} |e^{s\varphi} \varphi^{-1/2} g_{j,k}|_{L^2(-\delta, \delta)}^2 + \varphi_{|S}^{-1} |e^{s\varphi} \varphi^{1/2} h_{j,k}|_{L^2(-\delta, \delta)}^2 + s^{3/2} \lambda \varphi_{|S} e^{2s\varphi_{|S}} |\theta_{j,k}|^2 \right) \quad (1.5)$$

for s, λ sufficiently large (as we allow $C_\tau(x)$ to be discontinuous through S , $\mu_{j,k}(0^+)$ denotes $\lim_{x_n \downarrow 0^+} \mu_{j,k}(x_n)$). Note the peculiar weights in the right hand side (in brief r.h.s.).

The low frequencies are treated as in [7] and, still as in [7], we conclude by verifying that there exists a weight function β such that one can recover the spectrum of $(A_\tau(0^+), D_j(A_\tau(0^+)))$ (see Section 4). It remains to eliminate the three last terms of (1.5) (the additional terms with respect to [7]). The properties of the functions χ_j and the definition of c^j shall be used in this step:

$$\|\nabla \chi_j\|_\infty \leq C \sqrt{s\lambda\varphi|_S}, \quad \|\nabla \cdot (B\nabla \chi_j)\|_\infty \leq Cs\lambda\varphi|_S, \quad \|c^j - c\|_\infty \leq C \frac{1}{\sqrt{s\lambda\varphi|_S}},$$

as well as the weights of the second members obtained through the refined estimate. Collecting all the previous results we shall have proved Theorem 1.2 and this will conclude Section 4.

In order to point out the main ideas of this work, we have put almost all technical results in the appendix.

2 Preparation of data

2.1 The partition

Theorem 2.1. *For each pair (s, λ) , $s > 0, \lambda > 0$, there exist a finite family $(\Omega'_j)_{j \in J}$ of open sets such that $\overline{\Omega'} \subset \cup_j \Omega'_j$ and a partition of unity $(\chi_j)_{j \in J}$ subordinated to this open covering with*

$$\|\nabla_\tau \chi_j\|_\infty \leq C \sqrt{s\lambda\varphi|_S} \quad \text{and} \quad \|\nabla_\tau \cdot (C_\tau \nabla_\tau \chi_j)\|_\infty \leq Cs\lambda\varphi|_S, \quad (2.1)$$

where the constant C is independant on s, λ and j . Moreover, only N functions χ_j are non equal to 0 in each point of $\overline{\Omega'}$ with N only depending on Ω' .

As a matter of fact, the proof is tricky when Ω' is not a cube. In this case, we begin to define the $\Omega'_j := \Omega'_j(s, \lambda)$ such that $\overline{\Omega'} \subset \Omega'$. They are cubes of which the length of the edges is $h = h(s, \lambda)$. Next, we define the open sets Ω'_j that intersect $\partial\Omega'$. They are no more exactly cubes. The complete proof is given in Appendix A.

We recover Ω_δ by the family of cylindrical subdomains

$$\Omega_{j,\delta}(s, \lambda) = \{(x', x_n) \in \mathbb{R}^n; x' \in \Omega'_j(s, \lambda), -\delta < x_n < \delta\}.$$

In the sequel, we will denote $\Omega_{j,\delta} := \Omega_{j,\delta}(s, \lambda) = \Omega'_j \times (-\delta, \delta)$ and we recall that $\Omega_{j,\delta}^\pm = \{(x', x_n); x' \in \Omega'_j, 0 < \pm x_n < \delta\}$ (already quoted for (1.3)).

2.2 Partition and transverse operators

On each subdomain $\Omega_{j,\delta}$ we define the following approximation of the diffusion coefficient $c(x', x_n)$:

$$c^j(x_n) = \begin{cases} c_+^j(x_n) = \frac{1}{|\Omega'_j|} \int_{\Omega'_j} c(x', x_n) dx', & \forall x_n \in (0, \delta), \\ c_-^j(x_n) = \frac{1}{|\Omega'_j|} \int_{\Omega'_j} c(x', x_n) dx', & \forall x_n \in (-\delta, 0). \end{cases} \quad (2.2)$$

So, for each $x_n \in (-\delta, 0) \cup (0, \delta)$, we have given sense to (1.3) where the operators $A_\tau(x_n)$ act in a section of $\Omega_{j,\delta}^\pm$ parallel to the interface S_j . Similarly, we have $c^j(0^\pm)$. If Ω' is a cube, we can go straight to Lemma 2.2 taking into account the construction of the partition (see Step 2 in Annexe A) since we do not need to extend the coefficients. Otherwise, a problem remains with the open cylinders $\Omega_{j,\delta}(s, \lambda)$ intersecting $\partial\Omega$, which needs modifications in a neighborhood of $\partial\Omega'$. The idea is to extend the coefficients $c(x', x_n)$, outside Ω and independently of (s, λ) , in such a way that we control the behavior of the extended solutions u_j that are associated to these cylinders. The reader may refer to Appendix A for more explanations.

Now we mention the following result which will be useful in the next section.

Lemma 2.2. *With Assumption 1.1, we have*

$$\inf_{j \in J, k \geq 1} \inf_{x_n \in (-\delta, \delta)} \frac{\mu_{j,k}^2(x_n)}{\mu_{j,k}^2(0^+)} > 0, \quad \text{and} \quad \sup_{j \in J, k \geq 1} \sup_{x_n \in (-\delta, \delta)} \frac{\mu_{j,k}^2(x_n)}{\mu_{j,k}^2(0^+)} < +\infty. \quad (2.3)$$

Proof. We shall easily deduce these inequalities from the variational presentation of the Min-Max Principle since all the symmetric bilinear H_0^1 -coercive forms a_{τ, x_n, Ω'_j} of the operators $A_\tau(x_n)$ have same domain up to a translation of variables, i.e. $H_0^1(\Omega'_j)$. If V_k denotes the generic k -dimensional linear space of $L^2(\Omega'_j)$ and if V_k^\perp is its orthogonal space in $L^2(\Omega'_j)$ for the scalar product $(u, v) = \int uv \, dx'$ (specific notation to this Lemma, as well as $\|u\|^2 = (u, u)$), we know that

$$\mu_{j,k}^2(x_n) = \max_{V_{k-1} \subset L^2(\Omega'_j)} \left(\min_{u \in V_k^\perp \cap H_0^1(\Omega'_j), \|u\|=1} a_{\tau, x_n, \Omega'_j}(u, u) \right),$$

which implies, by Assumption 1.1,

$$c_{\min} \max_{V_{k-1} \subset L^2(\Omega'_j)} \left(\min_{u \in V_k^\perp \cap H_0^1(\Omega'_j), \|u\|=1} \|\nabla u\|^2 \right) \leq \mu_{j,k}^2(x_n) \leq c_{\max} \max_{V_{k-1} \subset L^2(\Omega'_j)} \left(\min_{u \in V_k^\perp \cap H_0^1(\Omega'_j), \|u\|=1} \|\nabla u\|^2 \right),$$

from which one may conclude

$$\frac{c_{\min}}{c_{\max}} \leq \frac{\mu_{j,k}^2(x_n)}{\mu_{j,k}^2(0^+)} \leq \frac{c_{\max}}{c_{\min}}. \quad (2.4)$$

■

Remark 2.3. When $\Omega'_j \cap \partial\Omega' \neq \emptyset$, we only have to modify, without repercussions, the values of c_{\min} and c_{\max} that appear in (2.4). We shall find again this situation throughout the proofs of this work.

In order to evaluate the awkward term $\int_S |e^{s\varphi} \nabla_\tau u|^2 \|[\beta' c C_\tau]_S\| \, d\sigma$ that occurs in (1.2), we have to estimate $\nabla_\tau u$ on the interface S . In fact, we need this estimate for $u_j := \chi_j u$. We write $u_j(x) = \sum_k u_{j,k}(x_n) \varphi_k(x', x_n)$ where the family $(\varphi_k(\cdot, x_n))_{k \geq 1}$ is an orthonormal basis associated to the eigenvalues of $A_\tau(x_n)$. So, the first line of (1.3) becomes

$$\mu_{j,k}^2(x_n) u_{j,k} - c^j(x_n) \partial_{x_n}^2 u_{j,k} = f_{j,k} + g_{j,k} + h_{j,k}, \quad 0 < |x_n| < \delta. \quad (2.5)$$

For $x_n = 0$, the same relation is valid on condition to distinguish the cases $x_n = 0^+$ and $x_n = 0^-$ for the coefficients $\mu_{j,k}^2$ and c^j . Finally, reasoning as in [7], section 2, we find

$$(c_{\max})^{-1} \sum_{k=1}^{\infty} \mu_{j,k}^2(x_n) |u_{j,k}(x_n)|^2 \leq \|\nabla_{\tau} u_j(\cdot, x_n)\|_{L^2(\Omega_j)}^2 \leq (c_{\min})^{-1} \sum_{k=1}^{\infty} \mu_{j,k}^2(x_n) |u_{j,k}(x_n)|^2. \quad (2.6)$$

2.3 The weight function β

The open set ω having been fixed in section 1.2, we choose a weight function β that satisfies the following properties.

Assumption 2.4. *The function $\beta \in \mathcal{C}^0(\Omega)$, and $\beta|_{\Omega^{\pm}} \in \mathcal{C}^2(\overline{\Omega^{\pm}})$ and*

$$\begin{aligned} \beta &\geq C > 0, \quad |\nabla_x \beta| \geq C > 0 \text{ in } \Omega \setminus \omega, \\ \beta &= \text{Cst on } \Omega' \times \{-H\} \quad \text{and} \quad \beta = \text{Cst on } \Omega' \times \{H\}, \\ \nabla_{x'} \beta &= 0 \text{ on } \partial\Omega' \times (-H, H), \\ \partial_{x_n} \beta &> 0 \text{ on } \Omega' \times \{-H\}, \quad \text{and} \quad \partial_{x_n} \beta < 0 \text{ on } \Omega' \times \{H\}. \end{aligned}$$

There exists a neighborhood V of S in Ω of the form $V = \Omega' \times (-\delta, \delta)$ in which β solely depends on x_n and is a piecewise affine function of x_n .

We draw reader's attention on two points: firstly, the trace $\beta|_S$ is constant on the interface S and, secondly, we can assume that $\omega \cap (\Omega' \times (-\delta, \delta)) = \emptyset$. Such a weight function β can be obtained by first designing a function that satisfies the proper properties at the boundaries and at the interface and then construct β by means of Morse functions following the method introduced in [12].

In the remainder of this paper we assume that $\partial_{x_n} \beta = \beta' > 0$ on S_+ and S_- , which means that the observation region ω is chosen in $\Omega' \times (0, H)$, i.e., where $x_n \geq 0$. As we can change x_n into $-x_n$ to treat the case of an observation $\omega \subset \Omega' \times (-H, 0)$, we lose nothing.

Note that Assumption 2.4 will be completed below by Assumption 4.1.

3 A refined estimation for the high frequencies of the tangential derivative

We recall that this section is a first step to achieve inequality (1.5). Taking into account (2.5) we fix, for the moment, $j \in J, k \in \mathbb{N}^*$ and consider w solution of

$$\begin{cases} \mu_{j,k}^2(x_n) w - c^j(x_n) \partial_{x_n}^2 w = F & \text{on } (-\delta, 0) \cup (0, \delta), \\ w(\pm\delta) = 0 \\ [w]_S = 0 \quad \text{and} \quad [c^j \partial_{x_n} w]_S = \theta, \end{cases}$$

with, here, $S = \{0\}$, $F \in L^2(-\delta, \delta)$, $\theta \in \mathbb{R}$. One has

Lemma 3.1. *Let F belong to $L^2(-\delta, \delta)$. There exist a constant C independent of s, λ, j, k , a constant $\mu_0 := \mu_0(s, \lambda) > 0$ such that for all $\mu_{j,k}(0^+) \geq \mu_0$, the following estimates are satisfied for*

s, λ sufficiently large and w solution of (3)

$$s\lambda\varphi_{|S}\mu_{j,k}(0^+)^2|e^{s\varphi}w|_S^2 \leq C(|e^{s\varphi}F|_{L^2(-\delta,\delta)}^2 + s^{3/2}\lambda\varphi_{|S}e^{2s\varphi_{|S}}|\theta|^2), \quad (3.1)$$

$$s\lambda\varphi_{|S}\mu_{j,k}(0^+)^2|e^{s\varphi}w|_S^2 \leq C(\varphi_{|S}|e^{s\varphi}\varphi^{-1/2}F|_{L^2(-\delta,\delta)}^2 + s^{3/2}\lambda\varphi_{|S}e^{2s\varphi_{|S}}|\theta|^2), \quad (3.2)$$

$$s\lambda\varphi_{|S}\mu_{j,k}(0^+)^2|e^{s\varphi}w|_S^2 \leq C(\varphi_{|S}^{-1}|e^{s\varphi}\varphi^{1/2}F|_{L^2(-\delta,\delta)}^2 + s^{3/2}\lambda\varphi_{|S}e^{2s\varphi_{|S}}|\theta|^2). \quad (3.3)$$

Remark 3.2. Even if Lemma 3.1 seems similar to Proposition 3.5 of [7] (for elliptic operator), there are two important differences: the weights for the sources F and the presence of θ which is 0 in this Proposition.

The difference among these three inequalities is the weight of the source terms. It should be noted that there is no comparison relation between them. The source terms resulting from the approximation of the coefficient c fall into three terms (see (1.4)). The first is just the localization of the initial source term, the second is the difference between the elliptic operator and its approximation and the third comes from the action of the cut-off function χ_j on the elliptic operator. As we shall see later, they should be treated differently to be absorbed by the r.h.s. of the Carleman estimate (1.2).

Proof. We begin to set

$$\sigma^2 := \inf_{j \in J, k \geq 1} \inf_{x_n \in (-\delta, \delta)} \frac{\mu_{j,k}^2(x_n)}{c^j(x_n)\mu_{j,k}^2(0^+)} \quad \text{and} \quad \mu_0 := \mu_0(s, \lambda) = \frac{2s\lambda\varphi_{|S}\beta'_{|S^-} + \lambda\beta'_{|S^-}}{\sigma}, \quad (3.4)$$

and next we introduce

$$W(x_n) = \frac{1}{2}s\lambda\varphi_{|S}e^{2s\varphi_{|S}}|w(x_n)|^2.$$

On the one hand it derives from (2.3) that we can choose $\sigma > 0$, on the other hand we observe that $W \geq 0$ and it verifies

$$\begin{cases} \partial_{x_n}^2 W - \sigma^2\mu_{j,k}(0^+)^2 W = \ell - \left(\sigma^2\mu_{j,k}^2(0^+) - \frac{\mu_{j,k}^2(x_n)}{c^j(x_n)}(2 - \gamma) \right) W := -d, & 0 < |x_n| < \delta, \\ W(-\delta) = W(\delta) = 0, \quad W(0^-) = W(0^+), \quad c_+^j W'(0^+) = c_-^j W'(0^-) + \theta w_{|S} s\lambda\varphi_{|S} e^{2s\varphi_{|S}} \end{cases}$$

with

$$\ell = \frac{1}{c^j} \left(-s\lambda\varphi_{|S}e^{2s\varphi_{|S}}Fw + s\lambda\varphi_{|S}e^{2s\varphi_{|S}}c^j(\partial_{x_n}w)^2 + \gamma\mu_{j,k}^2 W \right), \quad (3.5)$$

where the real number γ will be precised later and we have omitted the subscript j in S since the function β , and therefore φ , depends only on x_n if $-\delta < x_n < \delta$. Applying Lemma B.2, one gets ($c_\pm^j := c^j(0^\pm)$) to lighten the writing)

$$\begin{aligned} s\lambda\varphi_{|S}|\mu_{j,k}(0^+)e^{s\varphi_{|S}}w(0)|^2 &= \frac{2\mu_{j,k}(0^+)}{(c_+^j + c_-^j)} \int_0^\delta \frac{\sinh(\sigma\mu_{j,k}(0^+)(\delta - x_n))}{\sigma \cosh(\sigma\mu_{j,k}(0^+)\delta)} (c_+^j d(x_n) + c_-^j d(-x_n)) dx_n \\ &\quad - \frac{2\mu_{j,k}(0^+) \tanh(\sigma\mu_{j,k}(0^+)\delta) \theta w_{|S}}{\sigma(c_+^j + c_-^j)} s\lambda\varphi_{|S} e^{2s\varphi_{|S}} \end{aligned} \quad (3.6)$$

that is exactly the left-hand side of estimates of Lemma 3.1. Setting $r(x_n) := \sigma^2\mu_{j,k}^2(0^+) - \frac{\mu_{j,k}^2(x_n)}{c^j(x_n)}(2 - \gamma)$, we have $d(x_n) = r(x_n)W(x_n) - \ell(x_n)$ and, immediately, we note that the definition of σ implies

that $r(x_n) \leq 0$ as soon as $\gamma \leq 1$. So, we emphasize a non positive contribution that we can eliminate, namely

$$\int_0^\delta \frac{\sinh(\sigma\mu_{j,k}(0^+)(\delta - x_n))}{\sigma \cosh(\sigma\mu_{j,k}(0^+)\delta)} \left(c_+^j r(x_n)W(x_n) + c_-^j r(-x_n)W(-x_n) \right) dx_n \leq 0. \quad (3.7)$$

Now, we consider the contribution coming from $-\ell$ and, similarly to the previous result, the second term of (3.5) brings a non positive contribution since

$$-\int_0^\delta \frac{\sinh(\sigma\mu_{j,k}(0^+)(\delta - x_n))}{\cosh(\sigma\mu_{j,k}(0^+)\delta)} s\lambda\varphi_{|s} e^{2s\varphi_{|s}} \left(c_+^j (\partial_{x_n} w)^2(x_n) + c_-^j (\partial_{x_n} w)^2(-x_n) \right) dx_n \leq 0. \quad (3.8)$$

The estimate of the other terms of (3.6) needs more computations. Temporarily we forget the coefficient $\frac{2}{\sigma(c_+^j + c_-^j)}$ that we shall reinstate later. Let us begin by

$$I_\pm := -\mu_{j,k}(0^+) \int_0^\delta \frac{\sinh(\sigma\mu_{j,k}(0^+)(\delta - x_n))}{\cosh(\sigma\mu_{j,k}(0^+)\delta)} \frac{c_\pm^j}{c^j} \left(-s\lambda\varphi_{|s} e^{2s\varphi_{|s}} F(\pm x_n)w(\pm x_n) + \gamma\mu_{j,k}^2(\pm x_n)W(\pm x_n) \right) dx_n.$$

On one hand, applying the Young inequality we have, for any $\alpha > 0$,

$$\mu_{j,k}(0^+) |s\lambda\varphi_{|s} e^{2s\varphi_{|s}} F(\pm x_n)w(\pm x_n)| \leq \frac{1}{2\gamma\alpha} e^{2s\varphi_{|s}} |F(\pm x_n)|^2 + \frac{\gamma}{2} \alpha s^2 \lambda^2 \varphi_{|s}^2 e^{2s\varphi_{|s}} \mu_{j,k}^2(0^+) |w(\pm x_n)|^2,$$

and, on the other hand, observing that

$$\frac{\sinh(\sigma\mu_{j,k}(0^+)(\delta - x_n))}{\cosh(\sigma\mu_{j,k}(0^+)\delta)} = \frac{e^{\sigma\mu_{j,k}(0^+)(\delta - x_n)} - e^{-\sigma\mu_{j,k}(0^+)(\delta - x_n)}}{e^{\sigma\mu_{j,k}(0^+)\delta} + e^{-\sigma\mu_{j,k}(0^+)\delta}} \leq e^{-\sigma\mu_{j,k}(0^+)x_n},$$

we obtain

$$\begin{aligned} I_\pm &= \mu_{j,k}(0^+) \int_0^\delta \frac{\sinh(\sigma\mu_{j,k}(0^+)(\delta - x_n))}{\cosh(\sigma\mu_{j,k}(0^+)\delta)} \frac{c_\pm^j}{c^j} \left(s\lambda\varphi_{|s} e^{2s\varphi_{|s}} F(\pm x_n)w(\pm x_n) - \gamma(\mu_{j,k}^2 W)(\pm x_n) \right) dx_n \leq \\ &\quad \int_0^\delta \frac{e^{-\sigma\mu_{j,k}(0^+)x_n + 2s\varphi_{|s}}}{2\gamma\alpha} \frac{c_\pm^j}{c^j} |F(\pm x_n)|^2 dx_n + \\ &\quad \int_0^\delta \frac{\sinh(\sigma\mu_{j,k}(0^+)(\delta - x_n))}{\cosh(\sigma\mu_{j,k}(0^+)\delta)} \frac{c_\pm^j}{c^j} \frac{\gamma}{2} \mu_{j,k}^2(0^+) s\lambda\varphi_{|s} |e^{s\varphi_{|s}} w(\pm x_n)|^2 \left(\alpha s\lambda\varphi_{|s} - \frac{\mu_{j,k}^2(\pm x_n)}{\mu_{j,k}(0^+)} \right) dx_n. \end{aligned}$$

Assuming $\alpha \leq \frac{\beta'_{|s-}}{\sigma} \frac{c_{\min}}{c_{\max}}$, we see that $(\alpha s\lambda\varphi_{|s} - \frac{\mu_{j,k}^2(\pm x_n)}{\mu_{j,k}(0^+)}) \leq 0$ since we suppose $\mu_{j,k}(0^\pm) \geq \mu_0$.

That allows us to omit the corresponding term and gives $I_\pm \leq \int_0^\delta \frac{e^{-\sigma\mu_{j,k}(0^+)x_n + 2s\varphi_{|s}}}{2\gamma\alpha} \frac{c_\pm^j}{c^j} |F(\pm x_n)|^2 dx_n$. This term will be estimated by three different and non-comparable ways that will lead to the three estimates of Lemma 3.1.

Case 1. We follow exactly the way described in [7] (point 2(a) of section 4): replacing $\partial_t w$ by F and forgetting the dependance in t , we arrive to the condition $\sigma\mu_{j,k}(0^+) \geq 2s\lambda\beta' \varphi_{|s}$. As it is verified for $\mu_{j,k}(0^+) \geq \mu_0$, we have $I_\pm \leq \int_0^\delta \frac{e^{2s\varphi_{|s}}}{2\gamma\alpha} \frac{c_\pm^j}{c^j} |F(\pm x_n)|^2 dx_n$. This will lead to (3.1), the first estimate of Lemma 3.1.

Case 2. Since we suppose $\mu_{j,k}(0^+) \geq \mu_0$ with μ_0 defined in (3.4), the estimate (B.3) of Lemma B.1 leads to

$$I_{\pm} \leq \int_0^{\delta} e^{2s\varphi(\pm x_n)} \varphi_{|s} \frac{1}{2\gamma\alpha} \frac{c_{\pm}^j}{c^j} |\varphi^{-1/2}(\pm x_n) F(\pm x_n)|^2 dx_n,$$

which will give (3.2), the second estimate of Lemma 3.1.

Case 3. Always with the same hypothesis on $\mu_{j,k}(0^+)$, the estimate (B.2) of Lemma B.1 leads to

$$I_{\pm} \leq \int_0^{\delta} e^{2s\varphi(\pm x_n)} \varphi_{|s}^{-1} \frac{1}{2\gamma\alpha} \frac{c_{\pm}^j}{c^j} |\varphi^{1/2}(\pm x_n) F(\pm x_n)|^2 dx_n,$$

which will give (3.3), the third estimate of Lemma 3.1.

Moreover the last term in (3.6) verifies

$$\frac{2\mu_{j,k}(0^+) \tanh(\sigma\mu_{j,k}(0^+)\delta) \theta w_{|s}}{\sigma(c_+^j + c_-^j)} s\lambda\varphi_{|s} e^{2s\varphi_{|s}} \leq C \left(s^{3/2} \lambda\varphi_{|s} e^{2s\varphi_{|s}} |\theta|^2 + s^{1/2} \lambda\varphi_{|s} |\mu_{j,k}(0^+) e^{s\varphi_{|s}} w_{|s}|^2 \right),$$

which permits to conclude for s large enough if we collect these results with (3.7) and (3.8). \blacksquare

4 Proof of the Theorem 1.2

We start off the inequality (1.2) and, as we do not know the sign of the second parenthesis of the left-hand side, we have to improve our knowledge of the integrant which leads us to introduce the quadratic form

$$\mathcal{B}(u) = s\lambda\varphi_{|s} e^{2s\varphi} \left([c^2 \beta' |\partial_{x_n} u|^2]_S + |s\lambda\varphi u_{|s}|^2 [c^2 \beta'^3]_S \right)$$

(we can extract the function $e^{2s\varphi}$ since it is continuous) and

$$c_{\pm}(x') = c(x', 0^{\pm}), \quad L = \frac{\beta'_{|s_+}}{\beta'_{|s_-}}, \quad K_c(x') = \frac{c_-(x')}{c_+(x')}, \quad K_{\tau} = \|C_{\tau}(x', 0^-)(C_{\tau}(x', 0^+))^{-1}\|_{L^{\infty}(S)}$$

$$\underline{K}_c = \inf_{x' \in \Omega'} K_c(x'), \quad \overline{K}_c = \sup_{x' \in \Omega'} K_c(x').$$

Finally, we set

$$D = D(L) = \beta'_{|s_-} \sup_{x' \in \Omega'} \left(c_+(x') \|C_{\tau}(x', 0^+)\| \right) (L + \overline{K}_c K_{\tau})$$

and we make the following assumption on the weight function in addition to Assumption 2.4.

Assumption 4.1. *The weight function β is chosen such that $L \geq \underline{L} = \max\{\overline{K}_c, 2\}$ and*

$$\frac{(\underline{K}_c^2 + L^3(L - \underline{L}))}{(L + \overline{K}_c K_{\tau})(L - 1)} \geq \frac{36N \sup_{x' \in \Omega'} (c_+(x') \|C_{\tau}(x', 0^+)\|)}{\sigma^2 \inf_{x' \in \Omega'} c_+^2(x')}, \quad 2\delta\beta'_{|s_-} \leq \beta(0).$$

The integer N is the one of Theorem 2.1. The functions c, C_{τ} being fixed, it is the same for $\sigma^2, \underline{K}_c, \overline{K}_c, K_{\tau}$ and \underline{L} , which shows this inequality can be achieved by first choosing the value of $\beta'_{|s_-} > 0$ and then picking a sufficiently large value for L . The assumption $2\delta\beta'_{|s_-} \leq \beta(0)$ can easily be fulfilled since β is defined up to a constant.

Lemma 4.2. *We have*

$$\mathcal{B}(u) = s\lambda\varphi|_S e^{2s\varphi|_S} \left(B_1 |\gamma(u)|^2 + B_2 |s\lambda(\varphi u)|_S^2 \right),$$

with $\gamma(u) = (c\partial_{x_n} u)|_S + c_+ \beta'_{|S_-} \frac{L^2 - K_c}{L-1} (s\lambda\varphi u)|_S$ and where

$$B_1 = \beta'_{|S_-} (L-1), \quad B_2(x') = c_+^2(x') (\beta'_{|S_-})^3 \left(2(L^3 - K_c^2(x')) - \frac{(L^2 - K_c(x'))^2}{L-1} \right).$$

If β satisfies Assumption 4.1 we have $B_1 > 0$ and $B_2(x') \geq \mathbf{B}$, with \mathbf{B}

$$\mathbf{B} = \mathbf{B}(L) = \left(\inf_{x' \in \Omega'} c_+^2(x') \right) (\beta'_{|S_-})^3 \frac{K_c^2 + L^3(L-L)}{L-1}.$$

Remark 4.3. From the inequality $(a + \alpha b)^2 + b^2 \geq (1 + \alpha^2)^{-1} a^2$, we deduce that $s^{1/2} e^{2s\varphi|_S} |c\partial_{x_n} u|^2$ is less than the product of $(s^{1/2} \lambda\varphi|_S \inf(B_1, B))^{-1} \mathcal{B}(u)$ and of a constant C depending on L but not on (s, λ) , which we shall use to remove the last term in (4.4), absorbing it by the l.h.s. of (1.2) for (s, λ) large enough.

The idea of the proof of Lemma 4.2 is similar to both proofs of Appendix A.2 and Lemma 4.4 that are in [7].

It remains to estimate the tangential derivative of u at the interface S (the third integral of the second parenthesis in the l.h.s. of (1.2)). The wording of Theorem 2.1 points out an integer N and its existence implies that we have a constant C_n independent on our mesh such that

$$\mathcal{I} := s\lambda\varphi|_S \int_S \| [c\beta' C_\tau]_S \| |e^{s\varphi} \nabla_\tau u|^2 d\sigma \leq C_n s\lambda\varphi|_S \sum_{j \in J} \int_{S_j} \| [c\beta' C_\tau]_S \| |e^{s\varphi} \nabla_\tau u_j|^2 d\sigma.$$

Using $[c\beta' C_\tau]_S = c_+ \beta'_{|S_-} (L \text{Id}_{\mathbb{R}^{n-1}} - K_c C_{\tau-} (C_{\tau+})^{-1}) C_{\tau+}$, we obtain

$$\| [c\beta' C_\tau]_S \| \leq \beta'_{|S_-} \max(c_+ \|C_{\tau+}\|) (L + \bar{K}_c \|C_{\tau-} (C_{\tau+})^{-1}\|)$$

and, from (2.6), it suffices to estimate $\mathbf{D} s\lambda\varphi|_S \sum_{k \geq 1} \mu_{j,k}(0^+)^2 |e^{s\varphi} u_{j,k}|^2$ on S_j uniformly with respect to j . In order to solve this point, we shall distinguish two cases: the small values of k and the others.

Proposition 4.4. *There exists $C > 0$ such that, for all $j \in J, k \in \mathbb{N}^*$, we have*

$$\begin{aligned} \mathbf{D} s\lambda\varphi|_S |\mu_{j,k}(0^+) e^{s\varphi} u_{j,k}|_{S_j}^2 &\leq \frac{\mathbf{B}}{4N} (s\lambda\varphi|_S)^3 e^{2s\varphi|_S} |u_{j,k}|_{S_j}^2 + C \left(|e^{s\varphi} f_{j,k}|_{L^2(-\delta, \delta)}^2 + \varphi|_S |e^{s\varphi} \varphi^{-1/2} g_{j,k}|_{L^2(-\delta, \delta)}^2 \right. \\ &\quad \left. + \varphi|_S^{-1} |e^{s\varphi} \varphi^{1/2} h_{j,k}|_{L^2(-\delta, \delta)}^2 + s^{3/2} \lambda\varphi|_S e^{2s\varphi|_S} |\theta_{j,k}|^2 \right) \end{aligned} \quad (4.1)$$

for s, λ and L large enough.

Proof. We shall keep track of the dependency of the constants on j and k . For **low frequencies**, direct computations lead to

$$\mathbf{D} s\lambda\varphi|_S |\mu_{j,k}(0^+) e^{s\varphi|_S} u_{j,k}|_{S_j}^2 \leq \frac{\mathbf{B}}{4N} (s\lambda\varphi|_S)^3 e^{2s\varphi|_S} |u_{j,k}|_{S_j}^2, \quad (4.2)$$

as soon as $\mu_{j,k}(0^+) \leq \frac{1}{2\sqrt{N}} \sqrt{\frac{\mathbb{B}}{\mathbb{D}}} s \lambda \varphi_{|s}$.

Now, we look at the **high frequencies** with the definition (3.4) of μ_0 and we use Lemma 3.1 for $F = f_{j,k} + g_{j,k} + h_{j,k}$ and $\theta = \theta_{j,k}$: there exists a constant $C > 0$ such that we have

$$\begin{aligned} \mathbb{D} s \lambda \varphi_{|s} |\mu_{j,k}(0^+) e^{s\varphi_{|s}} u_{j,k}|_{S_j}^2 &\leq C \left(|e^{s\varphi} f_{j,k}|_{L^2(-\delta,\delta)}^2 + \varphi_{|s} |e^{s\varphi} \varphi^{-1/2} g_{j,k}|_{L^2(-\delta,\delta)}^2 + \varphi_{|s}^{-1} |e^{s\varphi} \varphi^{1/2} h_{j,k}|_{L^2(-\delta,\delta)}^2 \right. \\ &\quad \left. + s^{3/2} \lambda \varphi_{|s} e^{2s\varphi_{|s}} |\theta_{j,k}|^2 \right), \forall \mu_{j,k}(0^+) \geq \mu_0. \end{aligned} \quad (4.3)$$

Collecting (4.2) and (4.3), we have (4.1) but it remains to verify that one can recover all the spectrum of $A_\tau(0^+)$. This will be true as soon as there exists a weight function β such that, in addition of Assumption 2.4, it verifies

$$\frac{1}{2\sqrt{N}} \sqrt{\frac{\mathbb{B}}{\mathbb{D}}} s \lambda \varphi_{|s} \geq \frac{2s\lambda\varphi_{|s}\beta'_{|s_-} + \lambda\beta'_{|s_-}}{\sigma},$$

which will be achieved if, for $s\varphi_{|s} \geq 1/2$, one has $\frac{\mathbb{B}}{\mathbb{D}} \geq \frac{36N(\beta'_{|s_-})^2}{\sigma^2}$. This inequality is equivalent to

$$\frac{\inf_{x' \in \Omega'} (c_+^2(x')) (\beta'_{|s_-})^3 \frac{K^2 + L^3(L-L)}{L-1}}{\beta'_{|s_-} \sup_{x' \in \Omega'} (c_+(x') \|C_\tau(x', 0^+)\|) (L + \bar{K}_c K_\tau)} \geq \frac{36N(\beta'_{|s_-})^2}{\sigma^2}.$$

As β verifies Assumption 4.1 the previous estimate occurs and the proof is complete. \blacksquare

We now prove the following key result, providing an estimate of the tangential derivative of u .

Theorem 4.5. *There exist $C, \lambda_0 > 0$ and $s_0 > 0$ such that, for $s \geq s_0$ and $\lambda \geq \lambda_0$, we have*

$$\begin{aligned} s\lambda\varphi_{|s} \int_S e^{2s\varphi} |\nabla_\tau u|_S^2 \|[\beta' c C_\tau]_S\| d\sigma &\leq \frac{\mathbb{B}}{4} (s\lambda\varphi_{|s})^3 \int_S e^{2s\varphi} |u|_S^2 d\sigma \\ &\quad + C \left(\|e^{s\varphi} f\|^2 + s\lambda \|\varphi^{1/2} e^{s\varphi} \nabla u\|^2 + s^2 \lambda^2 \|\varphi^{3/2} e^{s\varphi} u\|^2 + s^{1/2} \int_S e^{2s\varphi} |c \partial_{x_n} u|^2 d\sigma \right). \end{aligned} \quad (4.4)$$

Proof. The proof is a consequence of two Lemmas:

Lemma 4.6. *There exists $C > 0$ such that for all $j \in J, k \in \mathbb{N}^*$, we have*

$$\varphi_{|s} \|e^{s\varphi} \varphi^{-1/2} g_j\|^2 + \varphi_{|s}^{-1} \|e^{s\varphi} \varphi^{1/2} h_j\|^2 \leq \frac{C}{s\lambda} \left(\|\varphi^{-1/2} e^{s\varphi} f_j\|^2 + (s\lambda)^2 \|e^{s\varphi} \varphi^{1/2} \nabla u\|^2 + s^3 \lambda^3 \|\varphi^{3/2} e^{s\varphi} u\|^2 \right).$$

for s and λ large enough.

Proof. We recall that $h_j = [A_\tau, \chi_j]u + (\partial_{x_n} c) \partial_{x_n} u_j$. Since $[A_\tau, \chi_j] + (\partial_{x_n} c) \partial_{x_n}$ is an operator of order 1 of which the coefficients depend on $\nabla_\tau \chi_j, \nabla_\tau \cdot C_\tau \nabla_\tau \chi_j$ and $\partial_{x_n} c$, and as $e^{s\varphi} \varphi^{\pm 1/2} \geq 1$, we can apply Theorem 2.1 to obtain

$$\begin{aligned} \varphi_{|s}^{-1} \|e^{s\varphi} \varphi^{1/2} h_j\|^2 &\leq C \left(s\lambda \|e^{s\varphi} \varphi^{1/2} \nabla u\|_{L^2(\Omega_{j,\delta})}^2 + s^2 \lambda^2 \varphi_{|s} \|e^{s\varphi} \varphi^{1/2} u\|_{L^2(\Omega_{j,\delta})}^2 \right), \\ \|e^{s\varphi} \varphi^{-1/2} h_j\|^2 &\leq C \left(s\lambda \varphi_{|s} \|e^{s\varphi} \varphi^{-1/2} \nabla u\|_{L^2(\Omega_{j,\delta})}^2 + s^2 \lambda^2 \varphi_{|s}^2 \|e^{s\varphi} \varphi^{-1/2} u\|_{L^2(\Omega_{j,\delta})}^2 \right). \end{aligned}$$

Moreover, because of (2.2) we have $\|c^j - c\|_\infty \leq C \frac{1}{\sqrt{s\lambda\varphi|_S}}$ where the constant C is independent on $j \in J$, and, as $g_j = -(c^j - c)\partial_{x_n}^2 u_j$, Lemma B.3 implies that for $\lambda > \lambda_1$, defined just after (B.7), one has

$$\varphi|_S \|e^{s\varphi} \varphi^{-1/2} g_j\|^2 \leq \frac{C}{s\lambda} \left\{ \|\varphi^{-1/2} e^{s\varphi} f_j\|^2 + s\lambda\varphi|_S \|\varphi^{-1/2} e^{s\varphi} \nabla u_j\|^2 + (s\lambda\varphi|_S)^2 \|\varphi^{-1/2} e^{s\varphi} u_j\|^2 + (s\lambda)^2 \|\varphi^{1/2} e^{s\varphi} \partial_{x_n} u_j\|^2 \right\}.$$

Gathering together the previous results we obtain

$$\begin{aligned} \varphi|_S \|e^{s\varphi} \varphi^{-1/2} g_j\|^2 + \varphi|_S^{-1} \|e^{s\varphi} \varphi^{1/2} h_j\|^2 &\leq \frac{C}{s\lambda} \left(\|\varphi^{-1/2} e^{s\varphi} f_j\|^2 + (s\lambda)^2 \|e^{s\varphi} \varphi^{1/2} \nabla u_j\|^2 + (s\lambda)^2 \|e^{s\varphi} \varphi^{1/2} \nabla u\|^2 \right. \\ &\quad \left. + s\lambda\varphi|_S \|e^{s\varphi} \varphi^{-1/2} \nabla u_j\|^2 + s^2 \lambda^2 \varphi|_S^2 \|e^{s\varphi} \varphi^{-1/2} u_j\|^2 + s^3 \lambda^3 \varphi|_S \|e^{s\varphi} \varphi^{1/2} u\|^2 \right). \end{aligned}$$

As soon as $\lambda > \lambda_1$, $s\lambda \geq 1$, the proof of the lemma is ended by noticing that $2\delta\beta'_{|S_-} \leq \beta(0)$ by Assumption 4.1 and, therefore, one has $\beta(0) \leq 2\beta(x_n)$ on $(-\delta, \delta)$ which implies $\varphi|_S \leq \varphi^2$. ■

Lemma 4.7. *There exists a constant $C > 0$ such that, for all $j \in J$, one has*

$$s^{3/2} \lambda \varphi|_S e^{2s\varphi|_S} |\theta_j|_{L^2(S_j)}^2 \leq C s^{1/2} e^{2s\varphi|_S} \int_{S_j} |c \partial_{x_n} u_j|^2 d\sigma.$$

Proof. The definition $\theta_j = [(c^j - c)\partial_{x_n} u_j]_{S_j}$ and (2.2) imply $|\theta_j|_{L^2(S_j)}^2 \leq \frac{C}{s\lambda\varphi|_S} |c \partial_{x_n} u_j|_{L^2(S_j)}^2$. Then the conclusion follows. ■

We recall that, for each $x' \in \Omega'$, there are no more N (N is the integer of Theorem 2.1) elements of J such that $\chi_j(x') \neq 0$. So the proof of Theorem 4.5 is ended by noticing that for any function f , we have

$$f^2 = \left(\sum_{j \in J} f \chi_j \right)^2 \leq N \sum_{j \in J} (f \chi_j)^2 \leq N^2 f^2$$

since $0 \leq \chi_j \leq 1$ and also since the convexity of the numerical function $z \rightarrow z^2$ implies that $\left(\sum_{1 \leq j \leq N} \frac{1}{N} a_j \right)^2 \leq \frac{1}{N} \sum_{1 \leq j \leq N} a_j^2$. ■

Finally we obtain Theorem 1.2 since the three terms involving u in the r.h.s. of (4.4) are absorbed by the l.h.s. of (1.2) : use Remark 4.3 for the integral on S while the two others are absorbed by the l.h.s. of (1.2) by choosing s, λ large enough.

A Partition of unity

In this appendix, in order to prove Theorem 2.1 and the following results, we construct a suitable lattice in a neighborhood of Ω' . The open set Ω' is a bounded set of \mathbb{R}^{n-1} and its closure is included in a cube $[a, b]^{n-1}$, $-\infty < a < b < \infty$. For the simplicity of the proof, we shall suppose that $[a, b] = [0, 1]$ since only the value of the constant C in (2.1) will change in the general case. We shall proceed gradually: in a first time (Step 1), we shall suppose that $\Omega' = (0, 1)$, then, in Step 2, we shall consider the case $\Omega' = (0, 1)^{n-1}$ and, at last, in Step 3, we use as far as possible some elementary arguments to obtain the generalization to any Ω' with our required regularity.

Step 1. We begin to work with $n = 2$ which means that the open cube is the interval $(0, 1)$.

Let us denote $h(s, \lambda) := \frac{\Theta}{\sqrt{s\lambda\varphi|_s}}$ where $\frac{1}{2} < \Theta \leq 1$ in such a way that $\frac{\sqrt{s\lambda\varphi|_s}}{\Theta}$ is an even natural integer $p = p(s, \lambda)$. For each $s, \lambda > 1$, there is a finite number of admissible values Θ . We shall choose the nearest value of 1.

In order to simplify our explanation, we work on $\tilde{S} := (-h, 1 + h)$. On \tilde{S} we consider the lattice

$$x_j(s, \lambda) = x_{j-1}(s, \lambda) + h(s, \lambda) \quad \text{where} \quad j = 0, \dots, p(s, \lambda), x_{-1}(s, \lambda) = -h \text{ and } x_{p+1}(s, \lambda) = 1 + h,$$

and we set

$$I_j(s, \lambda) = (x_{j-1}(s, \lambda), x_{j+1}(s, \lambda)), \quad 0 \leq j \leq p.$$

Two successive subintervals $I_j(s, \lambda)$ are overlaped each other and the intersection has a measure

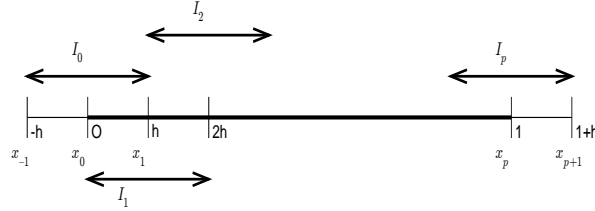

Figure 1: Covering in dimension 1

equal to h , half of the measure of each interval. Let us choose a function $\psi \in C_0^\infty(\mathbb{R})$ such that $0 \leq \psi(x) \leq 1$ and

$$\psi(x) = \begin{cases} 1, & \text{for } -\frac{1}{3} < x < \frac{1}{3}, \\ 0, & \text{for } x \notin (-\frac{2}{3}, \frac{2}{3}), \\ > 0, & \text{for } -\frac{2}{3} < x < \frac{2}{3}. \end{cases}$$

Let us consider now the functions ψ_j and χ_j defined by

$$\psi_j(x) = \psi\left(\frac{x - x_j}{h}\right), \quad \text{and for } -h \leq x \leq 1 + h, 0 \leq j \leq p, \quad \chi_j(x) := \frac{\psi_j(x)}{\sum_{0 \leq j \leq p} \psi_j(x)}. \quad (\text{A.1})$$

Remark A.1. The previous sum contains less than two terms not vanishing for each $x \in [-h, 1 + h]$, and the family $(\chi_j)_j$ is a partition of unity on $(0, 1)$ if we only consider the restrictions on $(0, 1)$ of each χ_j .

Lemma A.2. *There exists a constant C , independant of $s, \lambda > 0$ and $j, 0 \leq j \leq p$, such that*

$$\|(\chi_j)'\|_\infty \leq C \sqrt{s\lambda\varphi|_s}, \quad \text{and} \quad \|(\chi_j)''\|_\infty \leq Cs\lambda\varphi|_s. \quad (\text{A.2})$$

Proof. Deriving the function ψ_j , we have $|\psi_j'(x)| \leq \frac{\|\psi'\|_\infty}{h}$ and $|\psi_j''(x)| \leq \frac{\|\psi''\|_\infty}{h^2}$. From the definition of ψ_j , there exists a constant $m > 0$ ($m = 2$ for an appropriate choice of ψ) such that

$\sum_{0 \leq j \leq n+1} \psi_j(x) > 1/m$. Then, using $\chi_j'(x) = \frac{\psi_j'(x)}{\sum_{0 \leq j \leq n+1} \psi_j(x)} - \sum_{0 \leq j \leq n+1} \psi_j'(x) \frac{\psi_j(x)}{(\sum \psi_j)^2(x)}$, we have

$|\nabla \chi_j(x)| \leq 3m \frac{\|\psi'\|_\infty}{h}$. Similarly, Remark A.1 and the expression of $\chi_j''(x)$ give us the last estimation $|\chi_j''(x)| \leq \frac{2m}{h^2} (\|\psi''\|_\infty + 4m\|\psi'\|_\infty^2)$. ■

Step 2. Now, we come back to the cube $[0, 1]^{n-1}$, $n > 2$. The pair (s, λ) being fixed, we use $p = p(s, \lambda)$ defined in Step 1, and we build on each axis of coordinate a lattice similar to this one of Step 1. The product gives a lattice indexed by $j := (j_1, j_2, \dots, j_{n-1})$, $0 \leq j_i \leq p(s, \lambda)$, which defines the small cubes $\Omega'_j = I_{j_1} \times I_{j_2} \times \dots \times I_{j_{n-1}}$ where each I_{j_i} has the form introduced in the previous step. The measure of each cube is $(2h)^{n-1}$ and there is overlapping. We associate to each cube Ω'_j the function $\chi_j(x') := \chi_{j_1}(x_1)\chi_{j_2}(x_2)\dots\chi_{j_{n-1}}(x_{n-1})$. So, in each point $x' \in \overline{\Omega'}$, there are $q(x')$ functions of the partition not vanishing with $1 \leq q \leq 2^{n-1}$. The proof of Theorem 2.1 is complete in this case. Moreover, if $\Omega' = (0, 1)^{n-1}$ we can directly continue the coefficients c on each side of the boundary as we write it in item 2 of Step 3. The case $\Omega' \subsetneq (0, 1)^{n-1}$ needs a little more work.

Step 3. In the following, the open set Ω' is no more a cube but, in order to give an explanation very visual, we shall suppose $n = 3$ which means that Ω' is a bounded open set in $[0, 1]^2$ and $\partial\Omega'$ is \mathcal{C}^2 . The reader will see that the extension to $n > 3$ is easy once this approach will be understood. In subsection 1.3, we have reduced our problem to the family of problems (1.3) posed in slices indexed by x_n of the cylinder $\overline{\Omega'} \times (-\delta, \delta)$, slices with sizes of same order. As the lattice of Step 2 fails now on this point, we precise our modified approach in the 6 following items. We build in items 1 and 2 a finite covering (R_κ) of the boundary $\partial\Omega'$ using the \mathcal{C}^2 regularity of $\partial\Omega'$, covering that does not depend on Carleman parameters (s, λ) and that permits to extend the coefficients in a neighborhood of $\overline{\Omega'} \times (-\delta, \delta)$. Each R_κ corresponds to a true cube \tilde{R}_κ by a diffeomorphism. Then, once the pair (s, λ) is chosen, we distinguish the cubes far from the boundary (item 3) which come from the mesh of $[0, 1]^2 \supset \Omega'$ and the 'cubes' close to the boundary (item 4) which come from a meshing of \tilde{R}_κ . Choosing h small enough, we show in items 5 and 6 that the covering is complete and the partition of the unity is adapted.

1. We cover the boundary of Ω' by a finite family of open sets $(R_\kappa)_{1 \leq \kappa \leq N_b}$ in such a way that each R_κ is diffeomorphic by φ_κ to a rectangle $\tilde{R}_\kappa := (-\alpha_{\kappa 1}, \alpha_{\kappa 1}) \times (-\alpha_{\kappa 2}, \alpha_{\kappa 2})$ and $R_\kappa \cap \partial\Omega'$ is the image by φ_κ^{-1} of the straight line $\{0\} \times (-\alpha_{\kappa 2}, \alpha_{\kappa 2})$. Moreover, we can suppose that J_{φ_κ} , the Jacobian matrix of φ_κ , has a determinant equal to 1. So, $\bigcup_{\kappa=1}^{N_b} R_\kappa$ is an open neighborhood of $\partial\Omega'$ that contains the tube $T_{\delta'} := \{x \in \mathbb{R}^2; d(x, \partial\Omega') < \delta'\}$ for a some $\delta' > 0$ which is now fixed. We set $\tilde{R}_\kappa^\pm := \{y = (y_1, y_2) \in \tilde{R}_\kappa; \pm y_1 > 0\}$ and $R_\kappa^\pm := \varphi_\kappa^{-1}(\tilde{R}_\kappa^\pm)$.
2. To each R_κ and \tilde{R}_κ we associate the cylinders $R_{\kappa, \delta} := R_\kappa \times (-\delta, \delta)$, $\tilde{R}_{\kappa, \delta} := \tilde{R}_\kappa \times (-\delta, \delta)$ as well as the cylinders $R_{\kappa, \delta}^\pm$ and $\tilde{R}_{\kappa, \delta}^\pm$. We extend the functions w , defined on $\tilde{R}_{\kappa, \delta}$, by antisymmetry relatively to the plane $\{y_1 = 0\}$ and the coefficients $\tilde{c}_{rl}(\cdot, x_3) := c_{rl}(\varphi_\kappa^{-1}(\cdot), x_3)$ by symmetry relatively to the same plane. As a matter of fact, $\tilde{c}_{rl}(\cdot, x_3)$ is continuous on \tilde{R}_κ and \tilde{c}_{rl} is \mathcal{C}^1 on the four open subsets $\tilde{R}_{\kappa, \delta}^\pm \cap \{\pm x_3 > 0\}$ of $\tilde{R}_{\kappa, \delta}$. As it is usual, from $A_\tau(x_n)$ acting in $L^2(R_\kappa^+)$ we can define the extension $\tilde{A}_\tau(x_n)$ in \tilde{R}_κ with the tangential matrix $\tilde{C}_{\tau, \kappa}(\cdot, x_3) = (J_{\varphi_\kappa} \circ \varphi_\kappa^{-1}) C(\varphi_\kappa^{-1}(\cdot), x_3) (J_{\varphi_\kappa} \circ \varphi_\kappa^{-1})^t$, and come back to R_κ which gives the extended operator $A_\tau(x_n)$ acting in $L^2(R_\kappa)$. The new tangential matrix will be \mathcal{C}^1 since the map φ_κ is \mathcal{C}^2 .
3. Now, we take into account the parameters (s, λ) . Firstly, we use Step 2 to obtain a mesh of $[0, 1]^2$ by the family $(\Omega'_j) = (I_{j_1} \times I_{j_2})$. We keep the cubes Ω'_j such that $\overline{\Omega'_j} \subset \Omega'$. Let J_{int} be

the set of the corresponding subscripts. Since Ω' is not a cube, it is clear that $\cup_{j \in J_{int}} \Omega'_j$ does not fill Ω' . Therefore, we have to complete this family.

4. Using a process similar to Step 1 and 2, we build a covering for each rectangle \tilde{R}_κ with small cubes $\tilde{R}_{\kappa,l}$ overlapping each other and having a size equivalent to $2h(s, \lambda)$. Let J_b be this family of subscripts $j = (\kappa, l)$. We deduce functions $\tilde{\chi}_{\kappa,l}$ adapted to these cubes and take their images $\chi_{\kappa,l}$ using the functions φ_κ^{-1} , $1 \leq \kappa \leq N_b$ to come back to Ω' . In the same way we obtain $R_{\kappa,l}$ using φ_κ^{-1} , functions that do not depend on (s, λ) . This last remark is important to claim that all the $R_{\kappa,l}$ have sizes of the same order and that the functions $\chi_{\kappa,l}$ verify (2.1).
5. We have to show that the union of $(\cup_{j \in J_{int}} \Omega'_j)$ and $(\cup_{j \in J_b} R_j)$ covers $\overline{\Omega'}$. This will be true only if $h(s, \lambda)$ is small enough, i.e. if s and λ are large enough. Once this point will be verified, it will be sufficient to normalize the functions of the partition in a similar spirit to (A.1). However, the overlap must be important enough in order that all the functions of the partition do not vanish in a same point (in Step 1, the size of $I_{2k} \cap I_{2k+1}$ is half the length of each interval I_k , for example).

Note that $\cup_{j \in J_b} R_j \supset T_{\delta'}$ and that the partition has all the required properties for each $x' \in T_{\delta'/2}$. Let us consider $x' \in \Omega'$ such that $d(x', \partial\Omega') > \frac{\delta'}{2}$ which implies that the open disc $D(x', \frac{\delta'}{2}) \subset \Omega'$, while the cube $C(x', \frac{\delta'}{\sqrt{2}})$ of center x' with sides of length $L = \frac{\delta'}{\sqrt{2}}$ and parallel to axis of coordinates is inscribed in $D(x', \frac{\delta'}{2})$. To conclude, it will be sufficient to prove

Claim: If $h(s, \lambda) \leq \frac{L}{8}$, the point x' is recovered by cubes Ω'_j such that at least one of the associated function χ_j verifies $\chi_j(x') \neq 0$.

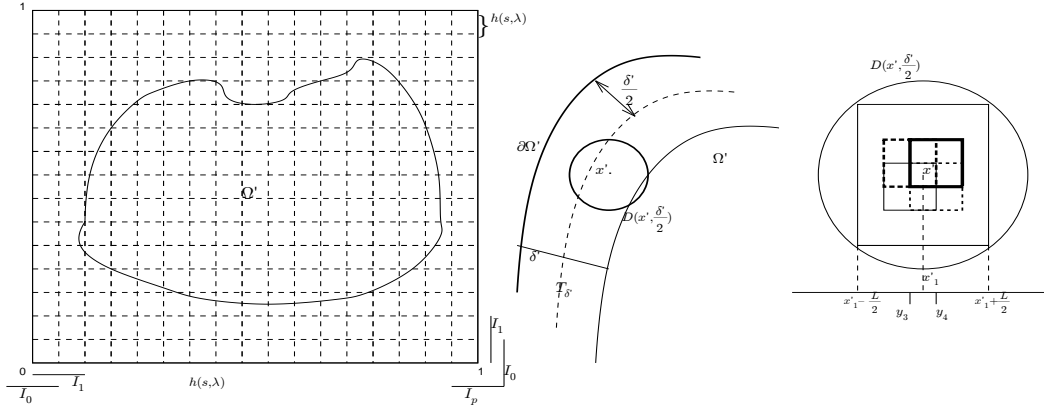

Figure 2: Claim

6. In order to prove the claim we suppose that $h(s, \lambda) = \frac{L}{8}$ (the other situations will come easily). The lattice used in Step 2 does not depend on Ω' . We project its points on each axis of coordinate. Let us consider the first axis of coordinate, i.e. the interval $(x'_1 - \frac{L}{2}, x'_1 + \frac{L}{2})$. The projection of the lattice give 7 points (y_1, \dots, y_7) or 8 points (y_1, \dots, y_8) included in $(x'_1 - \frac{L}{2}, x'_1 + \frac{L}{2})$. In the first case, $x'_1 = y_4$ and in the second case, $y_3 < x'_1 < y_4$. We repeat this

process for the second coordinate x'_2 . So, there are enough points of the lattice that surround x' in each direction to imply the result.

B Proof of some intermediate results

Lemma B.1. *Let*

$$\sigma\mu_{j,k}(0^+) \geq 2s\lambda\varphi_{|s}\beta'_{|s-} + \lambda\beta'_{|s-}. \quad (\text{B.1})$$

Then, for all function $g \in L^2(-\delta, \delta)$, we have

$$\int_0^\delta \varphi_{|s} e^{-\sigma\mu_{j,k}(0^+)y+2s\varphi_{|s}} g^2(\pm y) dy \leq \int_0^\delta \varphi(\pm y) e^{2s\varphi(\pm y)} g^2(\pm y) dy \quad (\text{B.2})$$

and

$$\int_0^\delta \varphi_{|s}^{-1} e^{-\sigma\mu_{j,k}(0^+)y+2s\varphi_{|s}} g^2(\pm y) dy \leq \int_0^\delta \varphi(\pm y)^{-1} e^{2s\varphi(\pm y)} g^2(\pm y) dy. \quad (\text{B.3})$$

Proof. Step 1. Let us prove the first estimate. Such kind of estimate is true if $\varphi_{|s} e^{-\sigma\mu_{j,k}(0^+)y+2s\varphi_{|s}} \leq \varphi(\pm y) e^{2s\varphi(\pm y)}$, for all $y \in (0, \delta)$, which we write

$$-\sigma\mu_{j,k}(0^+)y + 2s(\varphi_{|s} - \varphi(\pm y)) + \lambda(\beta_{|s} - \beta(\pm y)) \leq 0. \quad (\text{B.4})$$

Since $\beta' > 0$, φ is an increasing function on $(-\delta, \delta)$ and we have

$$\varphi(0) - \varphi(y) \leq 0 \quad \text{and} \quad (\beta_{|s} - \beta(y)) \leq 0, \quad y \in (0, \delta),$$

which gives the estimate (B.4) for $+y$. Let us prove that it is still valid for $-y$. Since the function β is affine on $(-\delta, 0)$, we have $\beta_{|s} - \beta(-y) = \beta'_{|s-}y$ for $y \in (0, \delta)$ whence

$$\varphi(0) - \varphi(-y) = y \int_0^1 \varphi'(-y + ry) dr = y\lambda\beta'_{|s-} \int_0^1 \varphi(-y + ry) dr.$$

For $r \in (0, 1)$, $\varphi(-y + ry) \leq \varphi(0)$ since $\beta' > 0$ and, so, we have $\varphi(0) - \varphi(-y) \leq y\lambda\beta'_{|s-}\varphi(0)$, which gives

$$-\sigma\mu_{j,k}(0^+)y + 2s(\varphi_{|s} - \varphi(-y)) + \lambda(\beta_{|s} - \beta(-y)) \leq -\sigma\mu_{j,k}(0^+)y + 2sy\lambda\beta'_{|s-}\varphi(0) + \lambda\beta'_{|s-}y, \quad y \in (0, \delta).$$

Using (B.1), the first estimate (B.2) is proved.

Step 2. To prove (B.3), we will prove that $\varphi_{|s}^{-1} e^{-\sigma\mu_{j,k}(0^+)y+2s\varphi_{|s}} \leq \varphi(\pm y)^{-1} e^{2s\varphi(\pm y)}$, for all $y \in (0, \delta)$. This is equivalent to prove that

$$-\sigma\mu_{j,k}(0^+)y + 2s(\varphi_{|s} - \varphi(\pm y)) - \lambda(\beta_{|s} - \beta(\pm y)) \leq 0.$$

Let us begin by the case with $-y$. As $\beta_{|s} - \beta(-y) \geq 0$ ($\beta' > 0$), it will be sufficient to prove that $-\sigma\mu_{j,k}(0^+)y + 2s(\varphi_{|s} - \varphi(-y)) \leq 0$. In the first step we have seen that $\varphi(0) - \varphi(-y) \leq y\lambda\beta'_{|s-}\varphi(0)$, whence

$$-\sigma\mu_{j,k}(0^+)y + 2s(\varphi_{|s} - \varphi(-y)) \leq -\sigma\mu_{j,k}(0^+)y + 2sy\lambda\beta'_{|s-}\varphi(0) \leq 0$$

with the assumption on $\mu_{j,k}$.

Now, let us consider the case with $+y$. As $\beta_{|s} - \beta(y) = -\beta'_{S_+} y$, we have to prove that $-\sigma\mu_{j,k}(0^+)y + 2s(\varphi_{|s} - \varphi(y)) + \lambda\beta'_{S_+} y \leq 0$. Using (B.1) this will be true whether $2s(\varphi_{|s} - \varphi(y)) + \lambda\beta'_{S_+} y \leq (2s\lambda\varphi_{|s}\beta'_{|S_-} + \lambda\beta'_{|S_-})y$. As $\varphi(y) - \varphi_{|s} \geq \lambda\varphi_{|s}\beta'_{S_+} y$, we conclude by noticing that, for $s \geq 1/2$, one has $\lambda\beta'_{S_+} \leq 2s\lambda\varphi_{|s}\beta'_{S_+} + 2s\lambda\varphi_{|s}\beta'_{|S_-} + \lambda\beta'_{|S_-}$. ■

Lemma B.2. *The solution of*

$$\begin{cases} v'' - \mu^2 v = F & s \in (-\delta, 0) \cup (0, \delta), \\ v(-\delta) = v(\delta) = 0, & v(0_-) = v(0_+), \quad c_+ v'(0_+) = c_- v'(0_-) + \theta \end{cases}$$

satisfies

$$v(0) = -\frac{c_+}{\mu} \int_0^\delta \frac{\sinh(\mu(\delta - \sigma))}{(c_+ + c_-) \cosh(\mu\delta)} F(\sigma) d\sigma - \frac{c_-}{\mu} \int_0^{-\delta} \frac{\sinh(\mu(-\delta - \sigma))}{(c_+ + c_-) \cosh(\mu\delta)} F(\sigma) d\sigma - \frac{\theta \tanh(\mu\delta)}{\mu(c_+ + c_-)}.$$

Proof. The solution of this system is of the form

$$v(s) = A_\pm \cosh(\mu s) + B_\pm \sinh(\mu s) + \mu^{-1} \int_0^s \sinh(\mu(s - \sigma)) F(\sigma) d\sigma.$$

For $s = 0_+$, we obtain $A_+ = v(0_+)$. Similarly, $s = 0_-$ gives us $A_- = v(0_-)$. Taking the derivative of the expression and considering $s = 0_\pm$, we also obtain $\mu B_+ = v'(0_+)$ et $\mu B_- = v'(0_-)$. Thus, for $s \in (-\delta, 0)$, we have

$$v(s) = v(0) \cosh(\mu s) + \frac{1}{\mu} \frac{c_+ v'(0_+) - \theta}{c_-} \sinh(\mu s) + \mu^{-1} \int_0^s \sinh(\mu(s - \sigma)) F(\sigma) d\sigma.$$

For $s \in (0, \delta)$, we obtain $v(s) = v(0) \cosh(\mu s) + \frac{1}{\mu} v'(0_+) \sinh(\mu s) + \mu^{-1} \int_0^s \sinh(\mu(s - \sigma)) F(\sigma) d\sigma$. Considering the conditions $v(-\delta) = v(\delta) = 0$, we obtain

$$\begin{cases} \frac{1}{\mu} \cosh(\mu\delta) \left[\mu v(0) - \frac{c_+ v'(0_+) - \theta}{c_-} \tanh(\mu\delta) + \int_0^{-\delta} \frac{\sinh(\mu(-\delta - \sigma))}{\cosh(\mu\delta)} F(\sigma) d\sigma \right] = 0 \\ \frac{1}{\mu} \cosh(\mu\delta) \left[\mu v(0) + v'(0_+) \tanh(\mu\delta) + \int_0^\delta \frac{\sinh(\mu(\delta - \sigma))}{\cosh(\mu\delta)} F(\sigma) d\sigma \right] = 0. \end{cases}$$

This can be written

$$A \begin{pmatrix} v(0) \\ v'(0_+) \end{pmatrix} = \begin{pmatrix} -\int_0^\delta \frac{\sinh(\mu(\delta - \sigma))}{\cosh(\mu\delta)} F(\sigma) d\sigma \\ -\int_0^{-\delta} \frac{\sinh(\mu(-\delta - \sigma))}{\cosh(\mu\delta)} F(\sigma) d\sigma - \frac{\theta}{c_-} \tanh(\mu\delta) \end{pmatrix} \text{ where } A = \begin{pmatrix} \mu & \tanh(\mu\delta) \\ \mu & -\frac{c_+}{c_-} \tanh(\mu\delta) \end{pmatrix}.$$

The determinant of this matrix being $D = \frac{-\mu}{c_-} \tanh(\mu\delta)(c_+ + c_-)$, we deduce the value of $v(0)$:

$$\begin{pmatrix} v(0) \\ v'(0_+) \end{pmatrix} = \frac{1}{D} \begin{pmatrix} -\frac{c_+}{c_-} \tanh(\mu\delta) & -\tanh(\mu\delta) \\ -\mu & \mu \end{pmatrix} \begin{pmatrix} -\int_0^\delta \frac{\sinh(\mu(\delta - \sigma))}{\cosh(\mu\delta)} F(\sigma) d\sigma \\ -\int_0^{-\delta} \frac{\sinh(\mu(-\delta - \sigma))}{\cosh(\mu\delta)} F(\sigma) d\sigma - \frac{\theta}{c_-} \tanh(\mu\delta) \end{pmatrix}.$$

Finally, we have

$$v(0) = -\frac{c_+}{\mu} \int_0^\delta \frac{\sinh(\mu(\delta - \sigma))}{(c_+ + c_-) \cosh(\mu\delta)} F(\sigma) d\sigma - \frac{c_-}{\mu} \int_0^{-\delta} \frac{\sinh(\mu(-\delta - \sigma))}{(c_+ + c_-) \cosh(\mu\delta)} F(\sigma) d\sigma - \frac{\theta \tanh(\mu\delta)}{\mu(c_+ + c_-)}.$$

■

Lemma B.3. *There exist $C > 0$ and $\lambda_1 > 0$ such that*

$$\|\varphi^{-1/2} e^{s\varphi} \partial_{x_n}^2 u_j\|^2 \leq C \left\{ \|\varphi^{-1/2} e^{s\varphi} f_j\|^2 + s\lambda\varphi_{|s} \|\varphi^{-1/2} e^{s\varphi} \nabla u_j\|^2 + (s\lambda\varphi_{|s})^2 \|\varphi^{-1/2} e^{s\varphi} u_j\|^2 + (s\lambda)^2 \|\varphi^{1/2} e^{s\varphi} \partial_{x_n} u_j\|^2 \right\}, \quad (\text{B.5})$$

for all $s \geq 1$, $\lambda \geq \lambda_1$ and $j \in J$.

Proof. In Ω^\pm , one has

$$\varphi^{-1/2} e^{s\varphi} c \partial_{x_n}^2 u_j = \varphi^{-1/2} e^{s\varphi} \partial_{x_n} (c \partial_{x_n} u_j) - \varphi^{-1/2} (\partial_{x_n} c) e^{s\varphi} \partial_{x_n} u_j. \quad (\text{B.6})$$

We see straightaway that

$$\|\varphi^{-1/2} (\partial_{x_n} c) e^{s\varphi} \partial_{x_n} u_j\| \leq c_{\max} (s\lambda)^2 \|\varphi^{1/2} e^{s\varphi} \partial_{x_n} u_j\|^2 \quad (\text{B.7})$$

if $s \geq 1$ and $\lambda > \lambda_1$ where $e^{\lambda_1 \|\beta\|_{L^\infty(\Omega)}} = \frac{1}{\lambda_1}$. The other term in (B.6) verifies

$$\begin{aligned} \partial_{x_n} (c \partial_{x_n} u_j) &= (\nabla \cdot B \nabla (\chi_j u)) - \nabla_\tau \cdot C_\tau \nabla_\tau u_j \\ &= -f \chi_j + 2(C_\tau \nabla_\tau u) \cdot \nabla_\tau \chi_j + (\nabla_\tau \cdot C_\tau \nabla_\tau \chi_j) u - \nabla_\tau \cdot C_\tau \nabla_\tau u_j. \end{aligned}$$

Let $\eta = \varphi^{-1/2} e^{s\varphi}$. Using (2.1), there exists $C > 0$ independent of s, λ, j such that

$$\|\eta \partial_{x_n} (c \partial_{x_n} u_j)\|^2 \leq C \left(\|\eta f_j\|^2 + s\lambda\varphi_{|s} \|\eta \nabla_\tau u\|^2 + (s\lambda\varphi_{|s})^2 \|\eta u\|^2 + \|\eta \nabla_\tau \cdot C_\tau \nabla_\tau u_j\|^2 \right), \quad (\text{B.8})$$

where the norms are taken in $L^2(\Omega_{j,\delta})$. It remains to estimate the last term of the r.h.s. of (B.8). Let us denote $\tilde{B} := \eta^2 B$, $\tilde{C} := \eta^2 C$ and let $\psi \in H_0^1(\Omega_{j,\delta})$ be a test function. One has

$$\begin{aligned} \int_{\Omega} \tilde{B} \nabla (\chi_j u) \cdot \nabla \psi &= \int_{\Omega} \{ (-\nabla \cdot \tilde{B} \nabla u) \chi_j - u \nabla_\tau \cdot (\tilde{C}_\tau \nabla_\tau \chi_j) - 2 \tilde{B} \nabla u \cdot \nabla \chi_j \} \psi \\ &= \int_{\Omega} \tilde{g}_j \psi \end{aligned}$$

where $\tilde{g}_j = -\nabla \cdot \tilde{B} \nabla (\chi_j u)$, which also leads to $\tilde{g}_j = (-\nabla \cdot \tilde{B} \nabla u) \chi_j - u \nabla_\tau \cdot (\tilde{C}_\tau \nabla_\tau \chi_j) - 2 \tilde{B} \nabla u \cdot \nabla \chi_j$. As $-\nabla \cdot (\tilde{B} \nabla u) = \eta^2 f - (\partial_{x_n} \eta^2) c \partial_{x_n} u$, we obtain

$$\tilde{g}_j = \eta^2 \left\{ f_j - 2B \nabla u \cdot \nabla \chi_j - u \nabla_\tau \cdot (C_\tau \nabla_\tau \chi_j) \right\} - \chi_j (\partial_{x_n} \eta^2) c \partial_{x_n} u.$$

For $h \neq 0$, parallel to the interface S , we set $D_h \rho(x) = \frac{\rho(x+h) - \rho(x)}{|h|}$, and take an any function $\psi \in H_0^1(\Omega_{j,\delta})$ such that $\psi = D_{-h}(D_h w)$ where $\text{supp } w \Subset \Omega_{j,\delta}$ (we suppose h small enough). On one side, we can write

$$\begin{aligned} \int_{\Omega} \tilde{B} \nabla u_j \cdot \nabla D_{-h}(D_h w) &= \int_{\Omega} \tilde{B} \nabla u_j \cdot D_{-h}(\nabla D_h w) \\ &= \int_{\Omega} D_h(\tilde{B} \nabla u_j) \cdot (\nabla D_h w) = \int_{\Omega} [\tilde{B}(x+h) D_h(\nabla u_j) + D_h(\tilde{B}) \nabla u_j] \cdot \nabla D_h w \end{aligned}$$

and, on the other side, we have

$$\int_{\Omega} \tilde{B} \nabla u_j \cdot \nabla D_{-h}(D_h w) = - \int_{\Omega} (\nabla \cdot \tilde{B} \nabla u_j) D_{-h}(D_h w)$$

since $[\eta^2 c \partial_{x_n} u_j]_S = 0$. There is no problem when $\overline{\Omega_{j,\delta}} \subset \Omega_\delta$, otherwise, for $\Omega_{j,\delta} \cap \partial\Omega \neq \emptyset$, the way we proceed to continue functions and coefficients does not introduce any new problem (see Appendix A). As $\tilde{g}_j = -\nabla \cdot \tilde{B} \nabla u_j$, we deduce from the two previous expressions the following relation

$$\int_{\Omega} \tilde{B}(x+h) D_h(\nabla u_j) \cdot \nabla D_h w = \int_{\Omega} (\tilde{g}_j D_{-h}(D_h w) - (D_h(\tilde{B}) \nabla u_j) \cdot \nabla D_h w). \quad (\text{B.9})$$

As η does not depend on the tangential variable, D_h and η commute. This gives

$$\left| \int_{\Omega} (D_h(\tilde{B}) \nabla u_j) \cdot \nabla D_h w \right| \leq C_1(B) |\eta \nabla u_j|_{L^2} |\eta \nabla D_h w|_{L^2}, \quad \left| \int_{\Omega} \tilde{g}_j D_{-h}(D_h w) \right| \leq |\eta^{-1} \tilde{g}_j|_{L^2} |D_{-h}(\eta D_h w)|_{L^2}.$$

It is wellknown that $|D_{-h} \tilde{w}|_{L^2} \leq |\nabla \tilde{w}|_{L^2}$ for $\tilde{w} \in H_0^1$ with $\text{supp } \tilde{w} \subset \Omega_{j,\delta}$ and h small enough. Similarly, we have $|D_{-h}(\eta D_h w)|_{L^2} \leq |\nabla_\tau(\eta D_h w)|_{L^2}$, from which one can conclude that

$$\left| \int_{\Omega} \tilde{g}_j D_{-h}(D_h w) \right| \leq |\eta^{-1} \tilde{g}_j|_{L^2} |\eta \nabla(D_h w)|_{L^2}.$$

We carry these two previous estimates on (B.9), which gives

$$\left| \int_{\Omega} \eta^2 (B(x+h) \nabla D_h u_j) \cdot \nabla D_h w \right| \leq (C_1(B) |\eta \nabla u_j|_{L^2} + |\eta^{-1} \tilde{g}_j|_{L^2}) |\eta \nabla(D_h w)|_{L^2}.$$

This inequality is, in particular, true if we choose w equal to u_j :

$$C_2(B) \left| \int_{\Omega} (\eta \nabla D_h u_j) \cdot \eta \nabla D_h u_j \right| \leq \left| \int_{\Omega} \eta^2 (B(x+h) \nabla D_h u_j) \cdot \nabla D_h u_j \right| \leq C_3 |\eta \nabla(D_h u_j)|_{L^2}$$

where the constants $C_1(B)$ and $C_2(B)$ depend on B but not on η and where $C_3 := C_1(B) |\eta \nabla u_j|_{L^2} + |\eta^{-1} \tilde{g}_j|_{L^2}$. Dividing the two extremities by $|\eta \nabla(D_h u_j)|_{L^2}$ we obtain $C_2(B) |\eta \nabla D_h u_j|_{L^2} \leq C_3$. For $1 \leq l \leq n-1$, and $\psi \in H_0^1(\Omega_{j,\delta})$, one obtains

$$\left| \int_{\Omega} (\partial_{x_l} u_j)(D_{-h} \psi) \right| = \left| \int_{\Omega} (D_h u_j)(\partial_{x_l} \psi) \right| = \left| \int_{\Omega} \eta (\partial_{x_l} D_h u_j) \eta^{-1} \psi \right| \leq \frac{C_3}{C_2(B)} |\eta^{-1} \psi|_{L^2}.$$

Letting h go to zero we obtain $\left| \int_{\Omega} (\partial_{x_l} u_j)(\partial_{x_k} \psi) \right| \leq \frac{C_3}{C_2(B)} |\eta^{-1} \psi|_{L^2}$ which leads to

$$|\eta \partial_{x_k} \partial_{x_l} u_j|_{L^2} \leq \frac{C_1(B) |\eta \nabla u_j|_{L^2} + |\eta^{-1} \tilde{g}_j|_{L^2}}{C_2(B)} \text{ for } 1 \leq k, l \leq n-1.$$

Now, we can estimate $\|\eta \nabla_\tau \cdot C_\tau \nabla_\tau u_j\|^2$, i.e.

$$\begin{aligned} \|\eta \nabla_\tau \cdot C_\tau \nabla_\tau u_j\|^2 &\leq C \left\{ \|\eta \nabla u_j\|^2 + \|\eta^{-1} \tilde{g}_j\|^2 \right\} \\ &\leq C \left\{ \|\eta \nabla u_j\|^2 + \|\eta f_j\|^2 + s \lambda \varphi_{|S} \|\eta \nabla u\|^2 + (s \lambda)^2 \|\eta^{-1} (\partial_{x_n} \eta^2) \partial_{x_n} u\|^2 + (s \lambda \varphi_{|S})^2 \|\eta u\|^2 \right\} \\ &\leq C \left\{ \|\eta f_j\|^2 + s \lambda \varphi_{|S} \|\eta \nabla u\|^2 + (s \lambda \varphi_{|S})^2 \|\eta u\|^2 + (s \lambda)^2 \|\eta^{-1} (\partial_{x_n} \eta^2) \partial_{x_n} u\|^2 \right\} \\ &\leq C \left\{ \|\varphi^{-1/2} e^{s\varphi} f_j\|^2 + s \lambda \varphi_{|S} \|\varphi^{-1/2} e^{s\varphi} \nabla u\|^2 + (s \lambda \varphi_{|S})^2 \|\varphi^{-1/2} e^{s\varphi} u\|^2 + (s \lambda)^2 \|\varphi^{1/2} e^{s\varphi} \partial_{x_n} u\|^2 \right\}. \end{aligned}$$

Bringing this result in (B.8), we deduce (B.5) with the help of (B.6) and (B.7). \blacksquare

C About the density in $D(A)$

The main ideas are in [1] where the authors proved the density in $H_0^1(\Omega)$ of $\mathfrak{D}(A) := \{u \in \mathcal{C}_0(\overline{\Omega}); u \in \mathcal{C}^2(\overline{\Omega^\pm}), c_+ \partial_{x_n} u = c_- \partial_{x_n} u \text{ on } S\}$, assuming that the matrix B is \mathcal{C}^2 on $\overline{\Omega^\pm}$. Lemma 3.2 in [1] implies that each $u \in D(A)$ is the limit in H_0^1 of a sequence $(u_n) \subset \{u \in \mathcal{C}_0(\overline{\Omega}); u \in \mathcal{C}^2(\overline{\Omega^\pm}), c_+ \partial_{x_n} u = c_- \partial_{x_n} u \text{ on } S\}$ with $Au_n \rightarrow_{L^2} Au$. The reader will see here a small extension resulting from a chat with J. Droniou that we thank warmly: the convergence is in norm and not only weak. In other words, $\mathfrak{D}(A)$ is a core of the operator A . We start knowing that the restriction to Ω^\pm of each $u \in D(A)$ belongs to $H^2(\Omega^\pm)$ (this claim is a consequence of Appendix A and the technics developed in the proof of Lemma B.3). We begin by the two following lemmas that are easy:

Lemma C.1. *If $\psi \in H_0^1(\Omega) \cap H^2(\Omega^\pm)$ one has*

$$\psi \in D(A) \iff [c \partial_{x_n} \psi]_S = 0.$$

Lemma C.2. *If the sequence $(\psi_n) \subset D(A) \cap H^2(\Omega^\pm)$ tends to $\psi \in D(A)$ for the topology of $H^2(\Omega^\pm)$ then $A\psi_n \rightarrow A\psi$ in L^2 .*

1. We set $c_\pm(x') = \lim_{\pm x_n \downarrow 0} c(x', x_n)$ and we call n_\pm the interior normal to the interface S relatively to Ω^\pm which enables us to introduce a change of variables \mathcal{C}^2 with the function $\Psi : \Omega' \times (-\varepsilon, \varepsilon) \rightarrow \mathcal{U}$ setting

$$\Psi(x', t) = \begin{cases} x' + tc_+(x')n_+(x') & \text{if } 0 \leq t \leq \varepsilon, \\ x' + tc_-(x')n_-(x') & \text{if } -\varepsilon \leq t \leq 0. \end{cases}$$

In our case, $n_\pm(x') = (0, \dots, 0, \pm 1)$ with the initial coordinates. We are seeing to appear the ask in point 2 of Assumption 1.1: the traces $c_\pm : x' \rightarrow c_\pm(x')$ are \mathcal{C}^2 . So, with the new coordinates, a function belonging to $H^2(\Omega^\pm)$ will keep this property in $\mathcal{U}^\pm := \Psi(\Omega^\pm)$ and if this function is 0 on $\partial\Omega$, it will be the same with the change. Idem for Ω^- and \mathcal{U}^- . As a matter of fact, we have replaced c by the value 1 on S .

2. Let $u \in D(A)$ be a function of which the support is included in Ω_δ and such that $u \in H^2(\Omega^\pm)$. Setting $v(x', t) := u(\Psi(x', t))$, we verify that $v \in H^1(\mathcal{U})$, $v \in H^2(\mathcal{U}^\pm)$ and

$$\partial_t v(x', 0^\pm) = c_\pm(x') \partial_{x_n} u(x', 0^\pm). \quad (\text{C.1})$$

So, the jump of ∂v at the interface is 0 which implies that $\partial_t v \in H^1(\mathcal{U})$. The tangential derivatives do not give any problem when we are going through the interface. In conclusion, the function v is belonging to $H^2(\mathcal{U}) \cap H_0^1(\mathcal{U})$.

3. There exists a sequence $(v_l) \subset \mathcal{C}^2(\mathcal{U})$ that tends to v for the topology of $H^2(\mathcal{U})$ and we set $u_l = v_l \circ \Psi^{-1}$. From the properties of Ψ , it comes that $u_l \in H^1(\Omega) \cap \mathcal{C}^2(\overline{\Omega^\pm})$ and $u_l \rightarrow u$ just as well for $H^1(\Omega_\delta)$ as for $H^2(\Omega_\delta^\pm)$. The relation (C.1) implies the continuity of the trace of $c \partial_{x_l}$ and from Lemma C.1 one has $u_l \in D(A)$ while Lemma C.2 gives the convergence of Au_l to Au in $L^2(\Omega_\delta)$.

Acknowledgement

The authors are grateful to F. Boyer (Université d'Aix-Marseille) for fruitful discussions on Appendix C.

References

- [1] L. Agelas, D. Di Pietro, and J. Droniou, *The G method for heterogeneous anisotropic diffusion on general meshes*, M2AN Math. Model. Numer. Anal. **44** (2010), no. 4, 597–625.
- [2] G. Alessandrini and L. Escauriaza, *Null-controllability of one-dimensional parabolic equations*, ESAIM Control Optim. Calc. Var. **14** (2008), no. 2, 284–293.
- [3] V. Barbu, *Exact controllability of the superlinear heat equation*, Appl. Math. Optim. **42** (2000), 73–89.
- [4] M. Bellassoued, *Carleman estimates and distribution of resonances for the transparent obstacle and application to the stabilization*, Asymptotic Anal. **35** (2003), 257–279.
- [5] A. Benabdallah, Y. Dermenjian, and J. Le Rousseau, *Carleman estimates for the one-dimensional heat equation with a discontinuous coefficient and applications*, Comptes Rendus Mécanique **334** (2006), 582–586.
- [6] ———, *Carleman estimates for the one-dimensional heat equation with a discontinuous coefficient and applications to controllability and an inverse problem*, J. Math. Anal. Appl. **336** (2007), 865–887.
- [7] ———, *Carleman estimates for stratified media*, JFA **260** (2011), 3645–3677.
- [8] A. L. Bukhgeim and M. V. Klibanov, *Global uniqueness of class of multidimensional inverse problems*, Soviet Math. Dokl. **24** (1981), 244–247.
- [9] T. Carleman, *Sur une problème d’unicité pour les systèmes d’équations aux dérivées partielles à deux variables indépendantes*, Ark. Mat. Astr. Fys. **26B** (1939), no. 17, 1–9.
- [10] A. Doubova, A. Osses, and J.-P. Puel, *Exact controllability to trajectories for semilinear heat equations with discontinuous diffusion coefficients*, ESAIM Control Optim. Calc. Var. **8** (2002), 621–661.
- [11] E. Fernández-Cara and E. Zuazua, *Null and approximate controllability for weakly blowing up semilinear heat equations*, Ann. Inst. H. Poincaré, Analyse non lin. **17** (2000), 583–616.
- [12] A. Fursikov and O. Yu. Imanuvilov, *Controllability of evolution equations*, vol. 34, Seoul National University, Korea, 1996, Lecture notes.
- [13] L. Hörmander, *Linear Partial Differential Operators*, Springer-Verlag, Berlin, 1963.
- [14] ———, *The Analysis of Linear Partial Differential Operators*, vol. IV, Springer-Verlag, 1985.
- [15] J. Le Rousseau, *Carleman estimates and controllability results for the one-dimensional heat equation with BV coefficients*, J. Differential Equations **233** (2007), 417–447.
- [16] J. Le Rousseau and N. Lerner, *Carleman estimates for elliptic operators with jumps at an interface: Anisotropic case and sharp geometric conditions*, Journées “Équations aux Dérivées Partielles”, 2010, Port d’Albret.
- [17] ———, *Carleman estimates for elliptic operators with jumps at an interface: Anisotropic case and sharp geometric conditions*, Preprint (2010).
- [18] J. Le Rousseau and L. Robbiano, *Carleman estimate for elliptic operators with coefficients with jumps at an interface in arbitrary dimension and application to the null controllability of linear parabolic equations*, Arch. Rational Mech. Anal. **105** (2010), 953–990.
- [19] ———, *Local and global Carleman estimates for parabolic operators with coefficients with jumps at interfaces*, Invent. Math. **183** (2011), 245–336.
- [20] G. Lebeau and L. Robbiano, *Contrôle exact de l’équation de la chaleur*, Comm. Partial Differential Equations **20** (1995), 335–356.

- [21] K. Miller, *Nonunique continuation for uniformly parabolic and elliptic equations in self-adjoint divergence form with Hölder continuous coefficients*, Arch. Rational Mech. Anal. **54** (1974), 105–117.
- [22] A. Pliš, *On non-uniqueness in Cauchy problem for an elliptic second order differential equation*, Bull. Acad. Polon. Sci. Sér. Sci. Math. Astronom. Phys. **11** (1963), 95–100.
- [23] C. Zuily, *Uniqueness and Non Uniqueness in the Cauchy Problem*, Birkhauser, Progress in mathematics, 1983.