



HAL
open science

A GRASP x ELS for the vehicle routing problem with three-dimensional loading constraints

Christophe Duhamel, Philippe Lacomme, H el ene Toussaint

► **To cite this version:**

Christophe Duhamel, Philippe Lacomme, H el ene Toussaint. A GRASP x ELS for the vehicle routing problem with three-dimensional loading constraints. 2011. hal-00704493

HAL Id: hal-00704493

<https://hal.science/hal-00704493v1>

Submitted on 6 Jun 2012

HAL is a multi-disciplinary open access archive for the deposit and dissemination of scientific research documents, whether they are published or not. The documents may come from teaching and research institutions in France or abroad, or from public or private research centers.

L'archive ouverte pluridisciplinaire **HAL**, est destin ee au d ep ot et  a la diffusion de documents scientifiques de niveau recherche, publi es ou non,  emanant des  tablissements d'enseignement et de recherche fran ais ou  trangers, des laboratoires publics ou priv es.

**A GRASP × ELS for the vehicle routing
problem with three-dimensional
loading constraints**

C. Duhamel¹, P. Lacomme¹, H. Toussaint¹

Research Report LIMOS / RR-11-01

January 2011

A GRASP×ELS for the vehicle routing problem with three-dimensional loading constraints

Christophe Duhamel, Philippe Lacomme
Hélène Toussaint

Laboratoire d'Informatique (LIMOS, UMR CNRS 6158), Campus des Cézeaux,
63177 Aubière Cedex, France.

Abstract

This paper addresses an extension of the Capacitated Vehicle Routing Problem where the client demand consists of three-dimensional weighted items (3L-CVRP). The objective is to design a set of trips for a homogenous fleet of vehicles based on a depot node which minimizes the total transportation cost. Items in each vehicle trip must satisfy the three-dimensional orthogonal packing constraints. A GRASP×ELS algorithm is proposed to compute the best possible solution. We propose a new method to address the 3D packing which allows items to be rotated or not. It is based on a relaxation of the 3D problem in which $(\mathbf{x}; \mathbf{y})$ items coordinates are first computed before getting compatible z-coordinates. Additional techniques are used to reduce as much as possible the time to check the 3D packing feasibility of trips. The effectiveness of our approach is evidenced through computational experiments on 3L-CVRP instances from the literature. New realistic instances are also proposed. These instances are based on the 96 French districts and encompass both small scale instances and large scale instances with up to 200 nodes

Keywords: Vehicle Routing, GRASP, Evolutionary local search, 3L-CVRP, 3D orthogonal packing

1 Introduction

1.1 Capacitated Vehicle Routing Problem and extensions with packing constraints

The Capacitated Vehicle Routing Problem (CVRP) is a classical NP-hard node routing problem which received a considerable amount of attention for decades [1] [2] [3]: it consists in optimally organizing vehicles trips in order to deliver goods required by a set of clients. It can be fully defined by considering a depot and a set of n clients. Each one corresponds to a node of a complete graph $G = (V, E)$ where V is a set of $n+1$ nodes, 0 being the depot and nodes $1..n$ being the clients. Each edge $e \in E$ has a finite cost $c_e \geq 0$ and each node $v \in V \setminus \{0\}$ is given a demand $d_v > 0$. A fleet of homogeneous vehicles of limited capacity Q is located at the depot. The objective is to design a set of trips of minimal total cost to service all clients. A trip is a cycle performed by one vehicle. It starts at the depot, visits a subset of nodes, before returning to the depot. The trip total load is upper bounded by the vehicle capacity. Since split deliveries are not allowed, each client is serviced by exactly one vehicle. As stressed in [4], exact methods can only solve small to medium instance. Thus, medium and large CVRP instances are typically addressed by metaheuristics.

The 2L-CVRP is an extension of the CVRP which includes two-dimensional orthogonal rectangle loading constraints (the 2L constraints). This problem is essentially addressed in [5][6][7]. It can be reduced to the CVRP when the size of the items is not considered or when items are 1×1 squares, thus dealing only with their weight. The 2L-CVRP resolution has been first addressed by Iori *et al.* [8] using a branch and cut approach limited to small scale instances (less than 25 clients). Then Gendreau *et al.* [5] introduced a tabu search algorithm. Zachariadis *et al.* [6] developed a guided tabu search. Fuellerer *et al.* [7] proposed an efficient version of the Ant Colony scheme to solve the 2L-CVRP. Recently, Duhamel *et al.* [9] introduced a multi-start evolutionary local search scheme which outperforms all previous published methods. The approach is original as it does not address the 2L-CVRP during the main optimization process but rather a relaxation into the so-called RCPSP-CVRP.

In the RCPSP-CVRP, the two-dimensional packing problem is relaxed into a RCPSP: at each point of the vehicle length the total width used must not exceed the vehicle width. Thus the vehicle width is related to the RCPSP resource availability. At the end of the main optimization process, the RSPCP-CVRP solution is transformed into a 2L-CVRP solution by a dedicated procedure. The authors showed in their experiments that most of the RCPSP-feasible solutions can be efficiently transformed into 2L-CVRP feasible solutions by only considering packing solutions which satisfy the previously computed x -abscissa.

The three-dimensional loading CVRP (3L-CVRP) is an extension of the 2L-CVRP where the height is also considered. More formally, each vehicle of the homogenous fleet is now defined by a weight capacity D and by a volume $V = L \times W \times H$ where L is the vehicle length, W is the vehicle width and H is the vehicle height (related to (x, y, z) coordinates). The demand of each client $i = 1 \dots n$ consists of a set of m_i items of total weight d_i . Each item $k = 1 \dots m_i$ is a three-dimensional cuboid of length l_{ik} , width w_{ik} and height h_{ik} . Each client must be serviced by exactly one vehicle, which is assigned to a single trip. A trip t is a sequence $t = (t_0, t_1, \dots, t_{n(t)}, t_{n(t)+1})$ of clients where $t_0 = t_{n(t)+1}$ corresponds to the depot. Each trip must be both “weight-feasible” and “packing-feasible”. A trip t is “weight-feasible” if the total weight of carried items does not exceed the vehicle capacity, *i.e.* $\sum_{i \in t} d_i \leq D$. It is “packing-feasible” if the client items can be loaded into the vehicle without overlapping and if it satisfies the classical orthogonal three-dimensional packing constraints. A set of “weight-feasible” and “packing-feasible” trips which involves all the clients defines a solution of the 3L-CVRP.

The 3L-CVRP has been addressed by Gendreau *et al.* [10] and more recently by Fuellerer *et al.* [11]. Only medium instances have been considered since three-dimensional packing problems are much harder to solve than their two-dimensional counterparts. The seminal publication of [10] introduces a tabu search algorithm that iteratively invokes a tabu search procedure for solving the inner loading sub-problem. Fuellerer *et al.* [11] introduce a highly efficient ant colony optimization algorithm which takes advantage of both fast packing heuristics for the loading sub-problem and of effective heuristics for the routing problem. These two publications also consider additional constraints about item fragility, LIFO unloading and support. Note that both instances from the literature and real-world instances were used by [10] to evaluate the performance of their method.

1.2 Cutting and Packing problems

1.2.1 General Cutting and Packing problems

Packing problems belong to the well-known family of **cutting and packing problems**. Many packing problems deal with the insertion of rectangular items in a rectangular bin in both two and three dimensions. They mostly differ on the objective function to optimize.

- The Three-Dimensional Bin Packing Problem (3BPP) consists in packing a set of rectangular boxes into a minimal number of identical rectangular boxes [12] [13];
- The Three-Dimensional Strip Packing Problem (3SPP) consists in packing a set of rectangular boxes into a strip of known width and infinite height so as to minimize the overall height of the packing [14] [15];
- The Three-Dimensional Packing Problem (3PP) consists in checking if a set of rectangular boxes can be packed into one bin (rectangle box) of fixed size, see [16] for instance.

Several extensions have also been addressed over time, including but not limited to, rotation of items, limitations on the total weight and/or item costs.

1.2.2 The 3D packing sub-problem in the 3L-CVRP

The packing problem within the 3L-CVRP falls into the last category (3PP) since each trip has to be “packing-feasible”. A 3PP instance consists of a set of items $I = \{1, \dots, n\}$ which have to be packed into a bin $B = (L; W; H)$ of length L , of width W and of height H . An item i has a length l_i , a width w_i and a height h_i ($l_i, w_i, h_i \in \mathbb{N}$).

A 3PP solution can be fully defined by the position of each item i , denoted (x_i, y_i, z_i) , into the bin. This position corresponds to the coordinates of its bottom-left corner. Item rotation is only allowed in the (x, y) plane as rotations in other planes may be prohibited in the corresponding real-life application (items often have a “top” side for instance). Moreover the packing must be orthogonal, *i.e.* the items must be placed with their edges parallel to the sides of the bin.

Some authors have added extra constraints:

- **fragility**: the items tagged as “fragile” cannot be put under another item;
- **support**: each item must have a minimum “supporting area”, *i.e.* a given percent of its basis must be defined by the top of other items (or by the floor of the bin);
- **LIFO**: the items of any client in the trip can be unloaded by only using straight movements, *i.e.* the items of a client i are not blocked by items of yet unvisited clients.

Such constraints correspond to realistic considerations in the industrial context of transportations and logistics. They are mandatory in many situations as CVRP solutions involving fully-loaded or nearly fully-loaded vehicles may not be 3L-CVRP feasible in practice, thus greatly reducing the interest of many CVRP commercial solvers.

2 GRASP×ELS framework for the 3L-CVRP

2.1 GRASP×ELS Principle

The GRASP×ELS [17] is a hybridization of the GRASP metaheuristic and of the ELS metaheuristic combining the positive features of both methods. The GRASP (Greedy Randomized Adaptive Search Procedure) [18] is a multi-start Local Search metaheuristic. At each iteration, an initial solution is constructed by using a greedy randomized heuristic. It is then improved by a local search and the best solution obtained at the end of each GRASP iteration is kept. The ELS (Evolutionary Local Search) [19] is an extension of the ILS (Iterated Local Search, [20]). At each iteration of the ELS, several copies of the current solution are done. Each copy is modified (mutation) before being improved by a Local Search. The best resulting solution is kept as the new current solution. The purpose of the ELS is to better investigate the neighbourhood of the current local optimum before leaving it, while the GRASP aims at managing the diversity during the solution space exploration. The framework we promote is a multi-start ELS in which the ELS is applied to the initial solutions generated by greedy randomized heuristics. Such an approach can also be viewed as a GRASP×ELS in which the ELS is used as Local Search. Besides combining GRASP with ELS, another important feature of our approach is the alternation between two solution spaces: the giant tour space and the 3L-CVRP solution space. By defining genuine exploration on those two search spaces and by defining projections from one search space into the other one, one can more easily avoid being trapped in local optima. The high quality solutions obtained by Prins [19] for the VRP, alternating between two search spaces (giant tour and VRP solutions) is a clear illustration of approaches which manage alternation between a set of giant tours and a set of solutions.

Two solution representations are used: solutions encoded as giant tours (TSP tours on the n clients) and 3L-CVRP solutions encoded as the set of trips (see Figure 1). Converting a 3L-CVRP solution into a giant tour is done by the *Concat* procedure. It consists in removing the depot from each trip and then concatenating the resulting trips into a single one. The reverse operation, *i.e.* converting a giant tour into a 3L-CVRP, requires more work. It is usually done by a dedicated splitting procedure (*Split*) and it relies on dynamic programming. Such an approach has been successfully applied to numerous routing problems including the Capacitated Arc Routing Problem, the Vehicle Routing Problem, the Location Routing Problem for instance, see [21] for a recent state of the art of Split in routing

problems. As a giant trip is not a direct representation of a 3L-CVRP solution, we have chosen the inner ELS to work on 3L-CVRP solutions while GRASP focuses on giant tours.

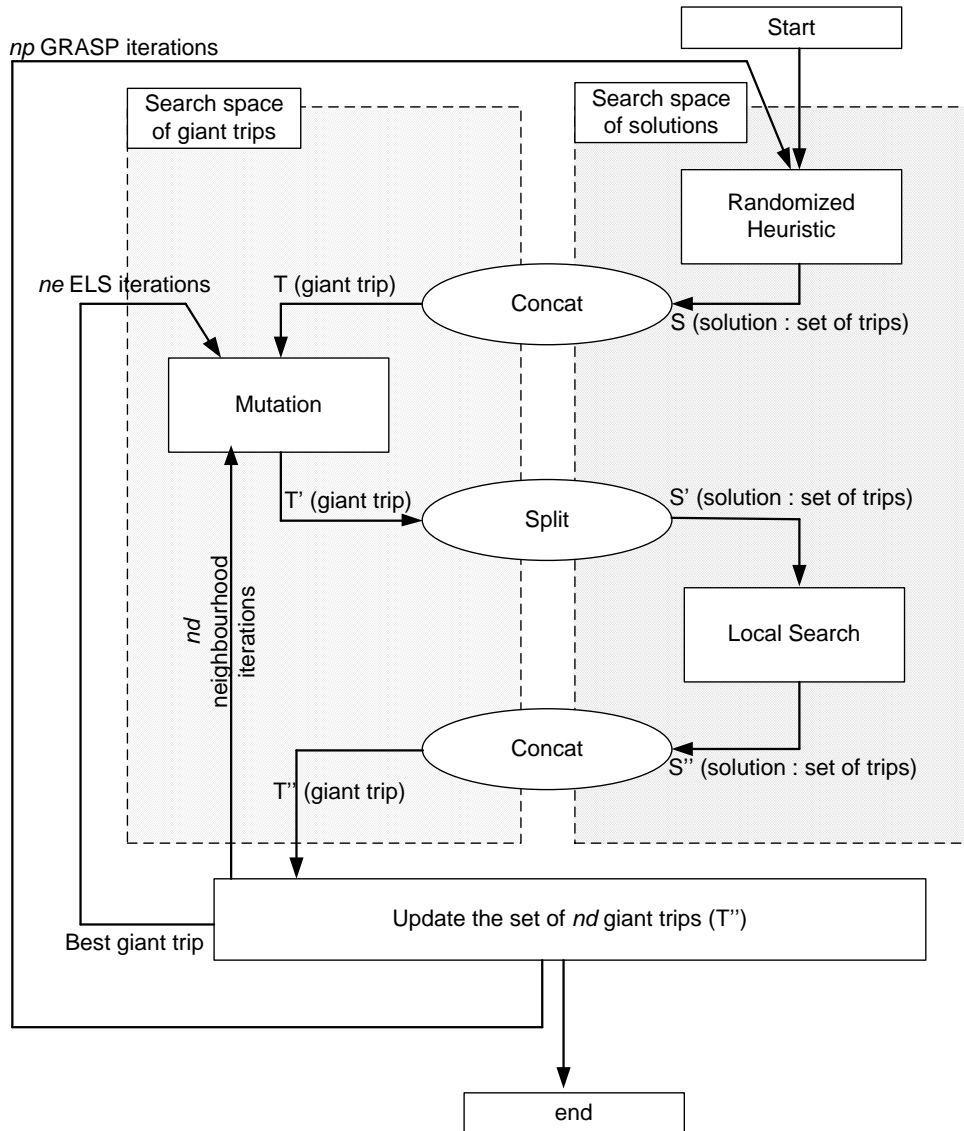

Figure 1: GRASP×ELS with alternation between the two search spaces

A random heuristic is required to generate an initial solution S (set of trips) at each iteration of GRASP. It is then transformed into a giant trip T before being perturbed in a way similar to the mutation operator in Genetic Algorithms. The resulting giant tour T' is split into 3L-CVRP trips which provides a solution S' . Then S' is improved using a Local Search operating on 3L-CVRP trips. The new solution S'' is associated to the giant trip T'' by trips concatenation and it becomes the incumbent solution (S, T) . During ELS, nd "children" are generated out of S , each one being mutated and improved by the local search. The best child replaces S . The process is iterated until ne iterations are done. The incumbent solution is updated before starting a new GRASP iteration.

The **Local Search** is defined as a first improvement descent method using several classical VRP neighborhoods to improve the initial 3L-CVRP solution: 2-Opt within a trip, 2-Opt between two trips, Swap within a trip and Swap between two trips. The **random heuristic** is indeed a randomized version of both the Path-Scanning heuristic and the heuristic of Golden *et al.* Thus, each call is likely to produce a different solution. The **mutation** operator is defined on the giant tour $T = (T_1, \dots, T_{n(T)})$,

where T_i is the i^{th} trip and where $n(T)$ is the number of trips in T . It first generates a new giant trip by modifying the concatenation order. Then some clients are exchanged to get the new giant trip T' .

2.2 Proposal for a new vehicle loading resolution approach

The approach we propose shares some similarities with the method we developed for the 2D packing problem in the 2L-CVRP [9]. For the 2L-CVRP, the original 2PP is first relaxed into a RCPSP with one resource, leading to the RCPSP-CVRP. A solution to the RCPSP-CVRP is then computed before being transformed back into a 2L-CVRP by using an efficient procedure. In most of the cases, the resulting 2L-CVRP solution is packing-feasible which means no other subsequent RCPSP-CVRP solution has to be investigated.

Unfortunately similar idea cannot be successfully applied to the 3L-CVRP. One should think that relaxing the 3PP sub-problem into a RCPSP with two resources (for example the width and the height) would also lead to the RCPSP-CVRP and most of the previous work could be re-used as well. However, the transformation of a RCPSP solution into a 3PP solution is often not possible as all the items are likely to be packed at the same location. Thus we propose a variation based on a 2-step procedure.

2.2.1 General process to solve the 3PP

Let $I = \{1, \dots, n\}$ be a set of items. The following two steps are performed to compute a solution to the 3PP:

- **Step 1:** (x_i, y_i) positions are computed for each item i . The 3D geometry of the items is relaxed and the height of the item is considered as a cost $c_i = h_i$. Thus the following sub-problem has to be solved: “Let I be a set of rectangular items i defined by their length l_i , their width w_i and their cost c_i , and let a rectangular bin be defined by its length L , its width W and its capacity C . Find a position (x_i, y_i) for each item i of I in the bin such that (i) the packing is orthogonal, (ii) the sum of the overlapping items costs does not exceed C ”. This step is addressed in part 2.2.2.
- **Step 2:** given the (x_i, y_i) positions obtained in Step 1, the z_i coordinates are computed such that (x_i, y_i, z_i) positions lead to a 3PP solution for the set of items I . Thus a 3PP has to be solved in this step, except that the solution is already partially defined. The resolution is fully detailed in part 2.2.3.

To the best of our knowledge, this kind of approach is original. However Gilmore and Gomory proposed in 1965 a stack building approach [22]. It consists in packing items stack after stack by solving a two-dimensional packing problem for each stack. The method we introduce is quite different since it does not solve as many two-dimensional packing problems. In fact, only one problem need to be solved in step 1 (which can be seen as a 3PP relaxation and not as a 2PP) and the solution is then transformed into a 3PP solution in Step 2.

2.2.2 Step 1: solving the relaxed 3PP

As stressed in section 2.2.1, the **arrangement problem** introduced in Step 1 is considered. It is defined as follows: let I be a set of rectangular items i defined by their length l_i , their width w_i and their cost c_i . Let a rectangular bin be defined by its length L , its width W and its capacity C . The problem consists in finding a (x_i, y_i) position for each item i of I in the bin such that (i) the packing is orthogonal, (ii) the sum of the overlapping items costs does not exceed C .

The arrangement problem has to be solved each time the packing feasibility is checked. Since the check has to be done each time a solution is modified, its time efficiency is crucial. Thus, for time efficiency, we propose a greedy (heuristic) approach where items are scanned in an ordered list O . The items in O are considered and tentatively placed into the bin while satisfying constraints (i) and (ii). This process is done by the `Solve_x_y_coordinate` procedure (see Algorithm 1).

The `Solve_x_y_coordinate` main loop uses a current position in the bin denoted by (pos_x, pos_y) . It tries to pack as many items from O as possible at this position. Any successfully packed item from O is removed from O . The (pos_x, pos_y) position is first initialized at the origin $(0, 0)$. It is then updated according to an increasing order of x -coordinates and y -coordinates. The way (x, y) coordinates are scanned allow us to state that an item i can be packed at the position (x, y) if:

$$\left\{ \begin{array}{l} x + l_i < L \\ y + w_i < W \\ \text{sum_cost}[x][k] + c_i \leq C \quad \forall k \in [y, y + w_i[\end{array} \right.$$

where $\text{sum_cost}[x][k]$ is the sum of the items costs which are overlapping at the position (x, k) .

The way the positions are scanned in the arrangement is crucial. One must look for empty spaces reduction above the items while limiting the items stow in order to be able to successfully solve the 3 dimensional packing in the following Step 2.

```

1.  procedure Solve_x_y_coordinate
2.  input parameters
3.    O : ordered set of items
4.    B : bin
5.  output parameters
6.    ok : boolean (true upon packing success)
7.    xi : x-position of item i
8.    yi : y-position of item i
9.  local parameters
10.   Lx : item list ordered on x values
11.   sum_cost : 2-dimensional array representing the bin area
12. begin
13.   Lx := {0} // ordered set of x value
14.   Ly := {0} // ordered set of y value
15.   ok := true
16.   iy := 1
17.   Initialize sum_cost to 0
18.   while ( (O ≠ ∅) and (ok = true) ) do
19.     posx := Lx[1] // first available position in Lx
20.     posy := Ly[iy] // next available position in Ly
21.     for i:=1 to Card(O) do
22.       item := O[i]
23.       if ( item can be packed at (posx, posy) ) then
24.         remove item from O
25.         (xitem, yitem) := (posx, posy)
26.         for k := posx to posx + item.length do
27.           for p := posy to posy + item.width do
28.             sum_cost[k][p] := sum_cost[k][p] + item.height
29.             add (posx + item.length) to Lx
30.             add (posy + item.width) to Ly
31.           endfor
32.         endfor
33.       endif
34.     endfor
35.     iy := iy + 1
36.     if (iy > Ly.size) then
37.       iy := 1
38.       remove Lx[1] from Lx
39.       if (Lx become empty) then ok := false endif
40.     endif
41.   endwhile
42. end

```

Algorithm 1: packing items in step 1

The main drawback of this approach is its greediness (heuristic). This means the local choices may lead to a packing failure although packing could be done. To prevent such wrong answers, one could consider a backtracking mechanism (like a tree search). However this would be computationally too expensive since `Solve_x_y_coordinate` is called a lot of times during the GRASP process. A partial workaround based on a look-ahead mechanism has been added. It consists in adding an extra condition when trying to pack one of the last three items from O : the candidate item i can be packed at the position $(posx, posy)$ only if the remaining items from O can be packed afterwards. Setting a limit of three remaining items has experimentally shown to be a good compromise between efficiency and time consumption.

A post processing step consists in spreading items over the bin. Indeed the way x and y coordinates are scanned leads to the items being packed as long as at the bottom-left side of the bin. As a consequence, the opposite area (top-right part of the bin) is not exploited the best possible way. Thus packed items are scanned in the decreasing order of their right edge position. Each item is then shifted as much as possible to its right (without introducing new overlaps). The same process is applied on y coordinates. This step reduces the number of overlapping items and makes the problem at step 2 easier to be solved.

2.2.3 Step 2: solving the 3PP using the partial solution computed at step 1

This step aims at computing a solution to the 3PP by using the solution found at Step 1. It consists in computing the z position of the items. The x and y positions have already been computed in Step 1. The idea is to scan the z coordinates, starting from 0. For each z value, as much items as possible are packed respecting their (x, y) position. This process ends when all items are packed or when the top of the bin is reached. The `Solve_z_coordinate` procedure is fully described in Algorithm 2.

```
1. procedure Solve_z_coordinate
2. input parameters
3.   O : ordered set of items
4.   x : set of positions in x ( $x_i$  = x-position of item i)
5.   y : set of positions in y ( $y_i$  = y-position of item i)
6.   B : bin
7. output parameters
8.   ok : boolean (true upon 3BPP success)
9.   z : set of positions in z ( $z_i$  = z-position of item i)
10. local parameters
11.   h : array [1...L][1...W] //h[x][y] = height already reached at (x,y)
12. begin
13.   z := 0
14.   ok := true
15.   while ( ok = true ) do
16.     for ( k := 1 to Card(O) ) do
17.       item := O[k]
18.       if ( item can be packed in position (item.x, item.y, z) ) then
19.         update h
20.          $z_{item} := z$ 
21.         remove item from O
22.       endif
23.       if ( z + item.height > B.height ) then
24.         ok := false
25.       endif
26.     endfor
27.   endwhile
28. end
29.
```

Algorithm 2 : computing z coordinate (step 2)

2.2.4 Whole packing feasibility check

As previously mentioned, a trip is feasible if (i) the total weight of the clients items does not exceed the vehicle capacity and if (ii) the items can be packed into the vehicle with respect to the 3PP constraints. Checking the first constraint is trivial. Checking the second constraint is trickier and we use the method described above. The global check is done by the `3D_Check_trip` procedure (see Algorithm 3). The procedure iteratively generates an ordered list O before checking it. It stops as soon as a packing has been found or when the maximal number of attempts has been reached. The procedure `Solve_x_y_coordinate` tries to identify a packing which relies on the ordered set O . Upon success, `Solve_z_coordinate` is called. Otherwise, the `Random_Neighborhood_Generation` generates a new list O' by randomly exchanging some items in O . Rotations are addressed by a random selection of item in O and by swapping their length and width.

```

1.  procedure 3D_Check_trip
2.  input parameters
3.    cli: set of clients
4.    nm, nm1, nm2 : maximal number of attempts
5.    V : vehicle (bin)
6.  output parameters
7.    xi : x-position of item i
8.    yi : y-position of item i
9.    zi : z-position of item i
10.   ok : boolean (true upon success)
11. begin
12.   O := items from cli
13.   k := 1, l := 1, j := 1           //number of iterations
14.   ok := false
15.   while (k < nm) and (ok = false) //main loop
16.     while (l < nm1) && (ok = false) //search for x and y coordinates
17.       O := Random_Neighborhood_Generation(O)
18.       (ok, x, y) := Solve_x_y_coordinate (O, V)
19.       l := l+1
20.     endwhile
21.     if (ok = true) then           //search for z coordinate
22.       ok = false
23.       while (j < nm2) and (ok = false)
24.         O := Random_Neighborhood_Generation(O)
25.         (ok, z) = Solve_z_coordinate(O, x, y, V)
26.         j := j+1
27.       endwhile
28.     endif
29.     k := k + 1
30.   endwhile
31. end

```

Algorithm 3: trip checking for 3D

2.2.5 Preliminary computation and storage

A lot of trips are evaluated during the optimization process. Moreover, same trip can be evaluated several times. Thus, a way to save time consists in avoiding unprofitable calls to `3D_Check_trip` (several runs with identical parameters) by saving the result (true or false) of each trip feasibility check. A dedicated data structure is used and it is updated along the GRASP×ELS process.

A combination of data structures can be introduced: three matrices are dedicated to trips which deliver from 2 to 4 costumers. Trips with a single client are trivially feasible, unless the instance is unfeasible. Note that items for one customer can be packable or not depending if items rotations are allowed or not. These matrices provide a $O(1)$ check if the trip has already been checked, either being packing-feasible or not. Otherwise the feasibility check is performed and the result is stored into the corresponding matrix. The major drawback is the huge memory footprint, especially for the last 4-dimensional matrix. Another data structure is used for trips involving more than 4 clients. It is a red-black tree (self-balancing binary search tree), see the seminal contributions [23] [24]. In associative data structures, each element is associated to a key which is used to find it back. Here the key corresponds to the set of clients of the trip without any relative order consideration. In order for the storage to be efficient, the relation between the keys and the trips should be as close as possible to a 1-1 correspondence. We propose the following key computation: given a trip $t = (t_0, t_1, \dots, t_{n(t)}, t_{n(t)+1})$, its key is generated by first computing the number of clients $n(t)$ in the trip. Then the client identification numbers are concatenated in the increasing order, leading to a value $v(t)$. For example, if $t = (0, 15, 8, 6, 12, 3, 0)$, then $n(t) = 5$ and $v(t) = 3681215$. Such an order is total since it is always possible to compare two different trips t and t' :

$$t < t' \Leftrightarrow \left\{ \begin{array}{l} n(t) < n(t') \\ \text{or} \\ (n(t) = n(t')) \text{ and } (v(t) < v(t')) \end{array} \right.$$

The search in a red-black tree is done in $O(\log(n))$ where n is the size of the tree.

The **Load_Resolution** procedure (see Algorithm 4) is in charge of evaluating a trip. This happens if the trip has never been evaluated or if it has been submit to less than p unproductive attempts there have been less than p failed evaluation (packing) attempts. For convenience, $\text{Store}(t)$ denotes the storing evaluation of the trip t . It is independent of the structure used to store the trip. $\text{Store}(t)$ has the following meaning:

$$\text{Store}(t) = \begin{cases} 0, & \text{if } t \text{ has never been evaluated} \\ 1, & \text{if } t \text{ is 3D feasible} \\ -\alpha, & \text{if } t \text{ has been evaluated } \alpha \text{ times and still not 3D feasible} \end{cases}$$

```

1. procedure Load_Resolution
2. input parameters
3.   t : trip
4.   p : number of 3D trip evaluation attempts
5.   nm, nm1, nm2 : maximal number of attempts for 3D_Check_trip procedure
6.   V : vehicle (bin)
7. output parameters
8.   ok : boolean (true upon success)
9. local parameters
10.  cli : set of clients in trip t
11. begin
12.   ok := false
13.   switch case:
14.     case Store(t) = 1
15.       ok := true
16.     endcase
17.     case Store(t) = -p
18.       ok := false
19.     endcase
20.     case (Store(t) ≠ -p) and (Store(t) ≠ 1)
21.       (x, y, z, ok) = 3D_Check_trip (cli, nm, nm1, nm2, V)
22.       if (ok = true) then
23.         Store(t) := 1
24.       else
25.         Store(t) := Store(t) - 1
26.       endif
27.     endcase
28.   endswitch
29. end

```

Algorithm 4: Vehicle Load Resolution

2.3 3D packing resolution example

Let us consider the instance E023-05s.DAT from [10]: 5 clients have to be serviced for a total of 12 items, detailed in Table 1.

	1	2	3	4	5	6	7	8	9	10	11	12
Client	C20	C20	C20	C1	C13	C13	C13	C7	C7	C22	C22	C22
Items	B1	B2	B3	B4	B5	B6	B7	B8	B9	B10	B11	B12
Length	36	29	29	34	14	24	15	15	22	18	22	19
Width	10	10	8	10	9	7	10	11	6	13	8	12
Height	10	8	9	13	11	7	8	17	12	11	11	17

Table 1: set of items to pack

2.3.1 Solving the arrangement problem (`Solve_x_y_coordinate`)

Let us consider the ordered list $O = (b_3, b_{12}, b_2, b_5, b_{10}, b_4, b_6, b_8, b_{11}, b_9, b_1, b_7)$ which leads to an arrangement solution. The next figures (from Figure 2 to Figure 7) illustrate the evolution of the arrangement process at different steps. The large rectangular area (60×25) corresponds to the bin while the small rectangles inside it are the items already packed. The number in the small rectangles is the total cost for the associated area of the bin. Let us remind that the item cost corresponds to its height. The limit on the cost (the bin height) is set to 30. For each figure, the last packed item is filled with dotted lines.

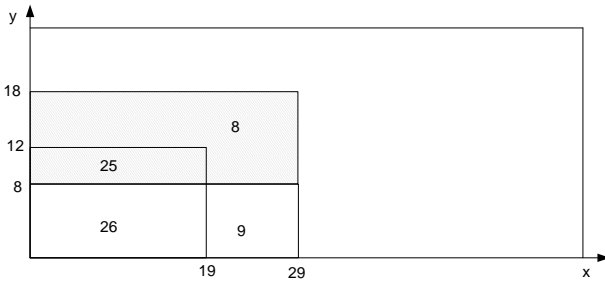

Figure 2: putting the first three items

The first two items b_3 and b_{12} are packed at position $(0, 0)$ and item b_2 is located at position $(0, 8)$ as stressed in Figure 2. The cost at the bottom-left side is the sum of b_3 cost and b_{12} cost ($9+17=26$) since items b_3 and b_{12} are overlapping at this area. The costs in the other rectangles are computed the same way considering the overlapped item.

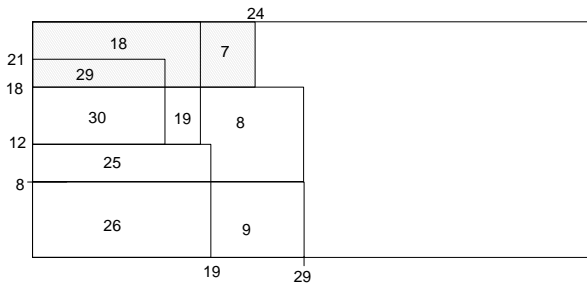

Figure 3: adding b_5 , b_{10} and b_6

No items can be packed in $(0, 8)$. Thus the next position investigated is $(0, 12)$ and all the remaining items in the list are scanned: the first packable item is b_5 and the second one is b_{10} . Then the position $(0, 18)$ is eligible for packing b_6 , which leads to the arrangement in Figure 3.

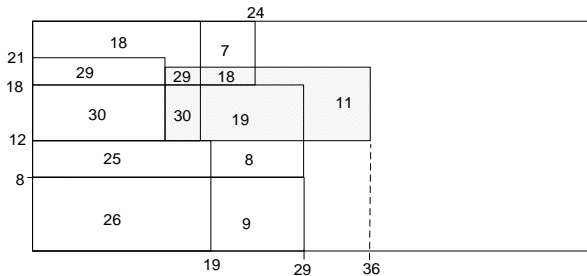

Figure 4: adding b_{11}

The method skips to abscissa 14, considering positions $(14;0)$, $(14;8)$ and $(14;12)$. The item b_{11} can be placed at $(14;12)$ leading to the packing solution of Figure 4.

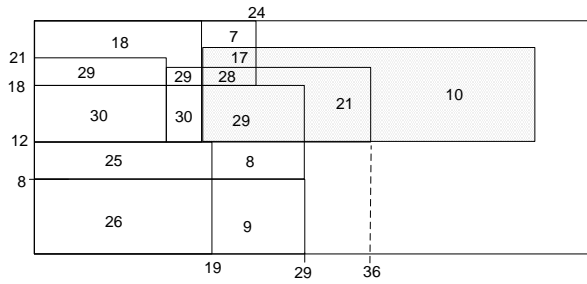

Figure 5: adding b_1

No item can be put at the next positions investigated. The first interesting position is (18, 12) where item b_1 can be placed.

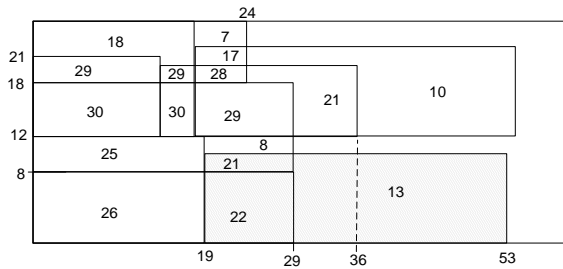

Figure 6: adding b_4

The next interesting position is (19, 0) where b_4 is placed. The remaining items to pack are b_8 , b_9 , and b_7 .

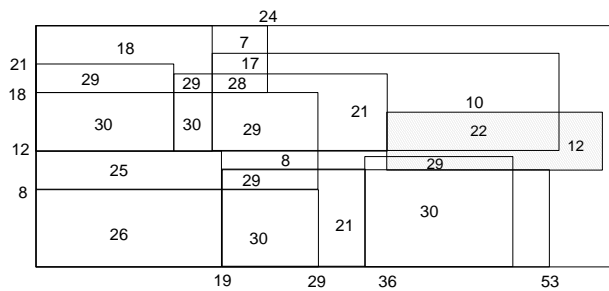

Figure 7: Final arrangement

Only b_7 can be placed at position (19, 0). The next position successfully investigated is (34, 0) where b_8 is placed and finally b_9 is placed at (36, 10).

The `Solve_x_y_coordinate` procedure has produced a compact arrangement and the computed position for each item are given in Table 2.

Items	B1	B2	B3	B4	B5	B6	B7	B8	B9	B10	B11	B12
x-coordinate	18	0	0	19	0	0	19	34	36	0	14	0
y-coordinate	12	8	0	0	12	18	0	0	10	12	12	0

Table 2: Items position after resolution of the arrangement problem

2.3.2 Items shift

Shifting the items is done iteratively along the x -axis and then along the y -axis until no further shift can be done. This process leads to the new items coordinates in Table 3.

Items	B1	B2	B3	B4	B5	B6	B7	B8	B9	B10	B11	B12
x-coordinate	24	1	1	26	2	0	30	45	38	6	16	7
y-coordinate	15	8	0	5	16	18	5	4	19	12	17	0

Table 3: Items position after items shift

2.3.3 Items packing in z (`Solve_z_coordinate` procedure)

The sequence from Figure 8 to Figure 13 illustrates the way the packing is built by `Solve_z_coordinate`. The ordered set of items is $O = (b_2, b_7, b_3, b_5, b_{11}, b_4, b_{10}, b_8, b_1, b_{12}, b_6, b_9)$. First coordinate $z = 0$ is investigated and as many items as possible are packed at this current z according to their (x, y) position and according to the O . Thus b_2, b_3, b_7, b_8, b_6 and b_9 are packed at $z = 0$ (see Figure 8). The current z is updated to the smallest available height, *i.e.* $z = 8$. Items b_5 and b_{11} can be packed leading to the partial vehicle load shown in Figure 9.

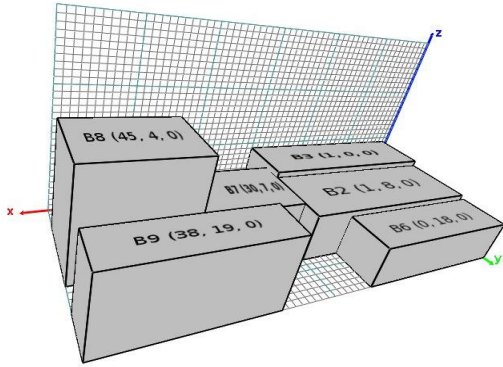

Figure 8: Packing items at $z = 0$

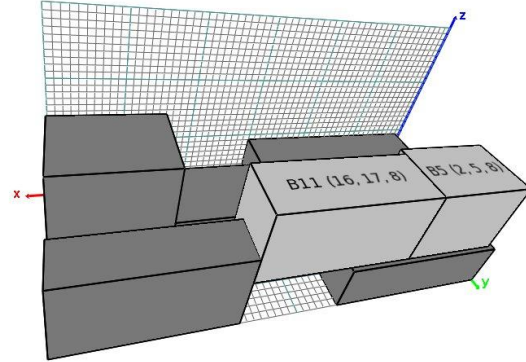

Figure 9: Packing items at $z = 8$

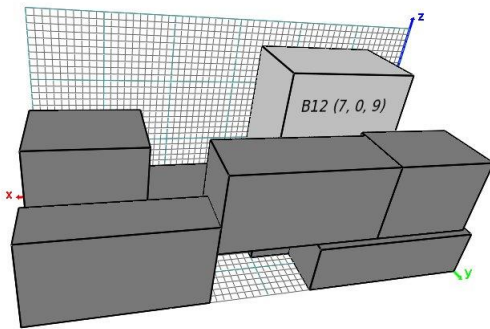

Figure 10: Packing items at $z = 9$

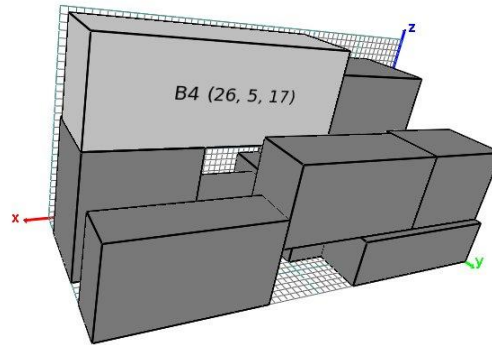

Figure 11: Packing items at $z = 17$

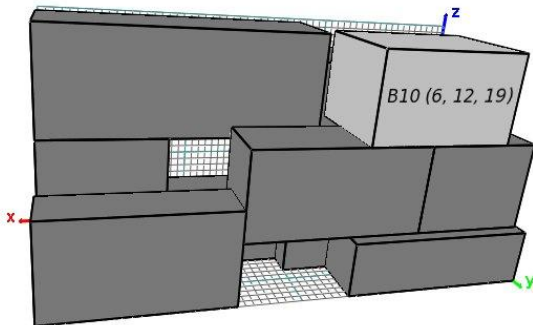

Figure 12: Packing item b_{10} at $z = 19$

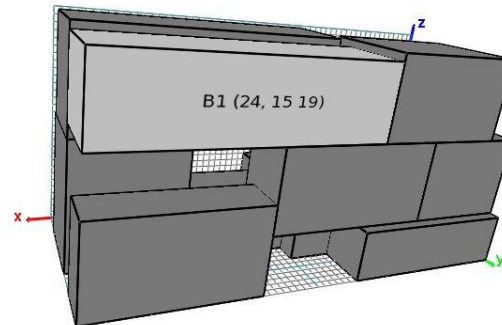

Figure 13: Packing item b_1 at $z = 19$

This process goes on with $z = 9$ where only b_{12} can be packed (Figure 10), $z = 17$ where only b_4 is packed (see Figure 11) and finally $z = 19$ where b_{10} and b_1 are packed. This leads to the final items packing in Figure 13.

Packing the items according to increasing values on the z -coordinate strategy usually produces dense layers with as much items as possible packed at the same time.

The final 3D-loading solution is shown in Table 4.

Items	B1	B2	B3	B4	B5	B6	B7	B8	B9	B10	B11	B12
x-coordinate	24	1	1	26	2	0	30	45	38	6	16	7
y-coordinate	15	8	0	5	16	18	5	4	19	12	17	0
z-coordinate	19	0	0	17	8	0	0	0	0	19	8	9

Table 4: 3D-packing solution

2.4 Split procedure

As previously mentioned, Split is a key-procedure which converts a giant tour into a 3L-CVRP solution (with respect to the sequence). It is based on the classical Split procedure [19][25][26], tuned to address the specific 3L-CVRP constraints.

Split first builds an auxiliary digraph $H_T = (X, Y, Z)$ where X is a set of $n+1$ nodes indexed from 0 to n . Node 0 is a dummy node, while the nodes $1 \dots n$ correspond to the client sequence of the giant tour $T = (v_1, \dots, v_n)$. An arc (i, j) belongs to Y if a trip servicing clients v_{i+1} to v_j (included) is both weight-feasible and 3D-feasible. The weight of the arc $(i, j) \in Y$ corresponds to the trip cost $z_{ij} = c_{0v_i} + \sum_{k=i \dots j-1} c_{v_k v_{k+1}} + c_{v_j 0}$. Optimally splitting T can be done by computing a min-cost path from node 0 to node n in H . An initial label is set at node 0. The labels are then propagated from node to node in H using the arcs. The best label at node n is kept as the optimal split.

Let $L_i^p = (N_i^p, z_i^p, k, j)$ be the p^{th} label assigned to node i . It corresponds to a feasible split of the initial clients $t_1 \dots t_i$ into trips. N_i^p is the number of vehicles still available, z_i^p is the cost of the trips previously built and (k, j) is the reference to its father label, e.g. L_j^k , the k^{th} label at node j . The initial label at node 0 is defined as $L_0^1 = (N, 0, -1, -1)$. It corresponds to the empty solution where all the vehicles are available. Propagating the label L_i^p along the arc $(i, j) \in A$ produces the label $L_j^q = (N_j^q, z_j^q, i, p)$ the following way:

- $N_j^q = N_i^p - 1$
- $z_j^q = z_i^p + z_{ij}$

Since a lot of labels are generated and stored at each node, the computational time can quickly grow. Thus dominance rules must be defined in order to keep a good time efficiency. A label L_i^p is said to dominate the label L_i^q if one of the following conditions holds:

$$\begin{cases} (N_i^p > N_i^q) \text{ and } (z_i^p \leq z_i^q) \\ (z_i^p < z_i^q) \text{ and } (N_i^p \geq N_i^q) \end{cases}$$

The critical path leading to the best final label defines the trips of the 3L-CVRP solution. The procedure `split` is detailed in Algorithm 5. For each node i , $NB[i]$ gives the number of associated labels. The procedure `Check_Domination_On_Node` checks if the new label L is dominated by another label at node j . The procedure `Insert` inserts this label into the set of labels from node j and removes the dominated labels. The number of labels is updated accordingly.

```

1.  procedure Split
2.  input parameters
3.    T: giant tour
4.  output parameters
5.    S: 3L-CVRP solution
6.  global parameter
7.    D : maximal vehicle weight capacity
8.    V : vehicle volume
9.     $d_i$  : total items weight of client  $i$ 
10.    $v_i$  : total volume of items located at client  $i$ 
11.    $c_{ij}$  : cost from client  $i$  to  $j$ 
12.   n : number of clients
13. begin
14.    $L_0^1 = (N, 0, -1, -1)$ ,  $s := \emptyset$ 
15.   pos_last := 0
16.   for  $i := 1$  to  $n$  do  $L_i := \emptyset$  endfor
17.   for  $i := 0$  to  $n - 1$  do
18.      $j := i + 1$ 
19.     trip :=  $\emptyset$ ; client :=  $\emptyset$ 
20.     repeat
21.       prev := client
22.       client :=  $T_j$ 
23.       trip := trip + client
24.       if ( $j = i + 1$ ) then
25.         trip_load :=  $d_{client}$ 
26.         trip_cost :=  $C_{depot,client} + C_{client,depot}$ 
27.         trip_volume :=  $v_{client}$ 
28.         set_boxes :=  $\emptyset$ 
29.         size := 0
30.       else
31.         trip_load := trip_load +  $d_{client}$ 
32.         trip_cost := trip_cost +  $C_{prev,client} + C_{client,depot} - C_{prev,depot}$ 
33.         trip_volume := trip_volume +  $v_{client}$ 
34.         size := size + 1
35.       endif
36.       check := (trip_load  $\leq$  D) and (trip_volume  $\leq$  V)
37.       if (check = true) then
38.         set_boxes := set_boxes +  $v_{client}$ 
39.         if ( $j \geq$  pos_last) and (size > 1) then
40.           res := Solve_3D(set_boxes)
41.         else res := true
42.         endif
43.         if (res = true) then // 3D packing successfully solved
44.           for  $p := 1$  to  $NB_i$  do
45.             let  $L_i^p = (N_i^p, z_i^p, k, j)$  be the current label
46.             propagate on  $j$ :  $L := (N_i^p - 1, z_i^p + trip\_cost, i, p)$ 
47.             if (Check_Domination_On_Node( $L_j^p$ ,  $j$ ,  $NB_j$ ) = false) then
48.               call Insert( $L$ ,  $j$ ,  $NB_j$ )
49.             endif
50.           endfor
51.         endif
52.        $j := j + 1$ 
53.     until (check = false) or ( $j > n$ )
54.     pos_last :=  $j$ 
55.   endfor
56.   if ( $NB_n > 0$ ) then
57.     S := call extract_trips ()
58.   endif
59. end

```

Algorithm 5: Split for the 3L-CVRP

3 Computational experiments

All procedures have been implemented in C++ and compiled using g++. Numerical experiments have been carried out on a 2.1 GHz Opteron computer running Linux operating system. The CPU power has been evaluated at around 4140 Mflops/s. The numerical experiments are based on two instance sets:

- a set of instances previously introduced in [10];
- a new set of instances based on the 96 French counties. To the best of our knowledge, this is the first step towards the definition of realistic and available instances for the 3L-CVRP. They are available for further experiments at <http://www.isima.fr/~toussain>.

Table 5 gives the set of parameters used for the two set of instances.

	Parameters definition	Parameters value
np	number of GRASP iterations	60
ne	number of ELS iterations	$15 + \min(6, \text{nbVehicule})$
nd	number of neighborhoods	10
p	maximal number of 3D trip evaluation	5

Table 5: parameters setting for the classical instances

3.1 Implementation and classical benchmarks used

We report results on the set of instances used in [10] and then in [11]. The number of clients varies from 15 to 100 and the total number of boxes varies from 32 to 198. The number of vehicles varies from 5 for the small instances to 28 for the largest ones. These instances can be downloaded at http://www.or.deis.unibo.it/research_pages/ORinstances/.

	<i>Nb clients</i>	<i>Nb items</i>	<i>Nb vehicles</i>
01	15	32	4
02	15	26	5
03	20	37	4
04	20	36	6
05	21	45	6
06	21	40	6
07	22	46	6
08	22	43	6
09	25	50	8
10	29	62	8
11	29	58	8
12	30	63	9
13	32	61	8
14	32	72	9
15	32	68	9
16	35	63	11
17	40	79	14
18	44	94	11
19	50	99	12
20	71	147	18
21	75	155	17
22	75	146	18
23	75	150	17
24	75	143	16
25	100	193	22
26	100	199	26
27	100	198	23

Table 6: instances characteristics

The details of the GRASP \times ELS solutions are available at <http://www.isima.fr/~lacomme>, <http://www.isima.fr/~toussain> and <http://www.isima.fr/~duhamel>. The GRASP \times ELS is compared with the Ant Colony Scheme of [11] and with the Tabu Search of [10].

The GRASP \times ELS is a random search algorithm. To provide a fair comparative study with Fuellerer's proposal, each instance has been solved ten times, the same way they did in their experiments. We report the average cost as well as the average CPU time to get the best solution over the 10 replications. Note that the best found solution over the 10 runs is also kept with the corresponding CPU time to reach it. The computational time of each method has been scaled by the speed factor presented in Table 7. This coefficient takes into account the MIPS performance of each processor.

	Gendreau <i>et al.</i> [10]	Fuellerer <i>et al.</i> [11]	GRASP \times ELS
Computer	PIV 3 GHz	PIV 3.2 GHz	Opteron 2.1 GHz
OS	?	Linux	Linux
Language	C	C++	C++
Speed factor	0.94	1	0.66
Time limit	1h	1h	1h30
Nb of runs	1	10	10

Table 7: comparative performance of processors

All previously published methods were benchmarked over 1 hour of computational time, *i.e.* 1 hour of computation is assigned for one run of the methods. Since the reference results [11] have been obtained on a computer which is 1.5 times faster than ours, the GRASP \times ELS time limit is set to 1h30.

3.2 Average results for 3L-CVRP instances

A summary of the results is presented in Table 8 for the three methods. For each method, the number of time the method gives the best published method (line 2), the number of time the method compete with the best one (line 3) and the number of time the method is worst (line 4) are reported. The results show that the GRASP \times ELS find the best solution for 16 out of 27 instances and outperforms both the Tabu search from Gendreau *et al.* [10] and the Ant colony Scheme from Fuellerer *et al.* [11]. The average value 846.1 is also the best.

	Gendreau <i>et al.</i> [10]	Fuellerer <i>et al.</i> [11]	GRASP \times ELS	GRASP \times ELS
rotation	yes	yes	yes	no
nb best	0	2	16	14
nb of equal	7	7	8	6
Nb of worst	20	18	3	7
avg value	876.31	856.7	847.04	848.88
best value	?	?	841.96	845.48

Table 8: average GRASP \times ELS performance, with and without rotations

Two versions of GRASP \times ELS are provided in order to evaluate the consequence of allowing items rotation or not. Quite surprisingly, forbidding items rotation does not deteriorate that much the solution. On average, our method produces solutions that are 3 units higher. Thus rotations do not seem to play a significant role for this set of instances. When carefully checking the results (see the Appendix), one can note that the solution is the same, with and without items rotation, for half the instances.

3.3 Hash function performances on results

The hash function kept in memory the 3D packing results leading to a learning algorithm in order to save time during process. The saving time increased over replications since the hash tables are not erased between replications.

Impact of hash function can be easily evidenced in numerous instances including the instance 07 shown in Table 9. For this instance the limit is fixed to 63000 iterations. The total time to perform those iterations is about 3079.4 s in the first replication. It quickly drops in the second iterations (1475.4 s). The time difference corresponds to the packing results kept in memory in the first replication since both replications have exactly the same parameters. We can notice that the total time decreases over the 10 replications, dropping from 3000 s to 700 s.

	S_{best}	total time (s)
Replication 1	732.51	3079.4
Replication 2	732.51	1475.4
Replication 3	725.70	1228.7
Replication 4	732.51	1082.4
Replication 5	727.27	959.7
Replication 6	725.70	840.6
Replication 7	732.51	854.6
Replication 8	727.54	792.8
Replication 9	725.43	729.9
Replication 10	727.03	728.6

Table 9: GRASP×ELS performances over the 10 iterations

3.4 Example of a 3L-CVRP solution

Let us consider the instance 08 with 22 clients to service, 43 items to load and 8 vehicles available. The GRASP × ELS provides a solution of value 730 which is better than the solution given by the Ant Colony Scheme [11]. This solution is made of 5 trips: Figure 14 provides a graphical representation of the trips.

- Trip 1: Depot, 14, 17, 22, 20, 19, Depot
- Trip 2: Depot, 11, 13, 9, 5, 4, 7, Depot
- Trip 3: Depot, 16, 15, 3, 2, 1, 6, 12, Depot
- Trip 4: Depot, 21, 8, 10, Depot
- Trip 5: Depot, 18, Depot

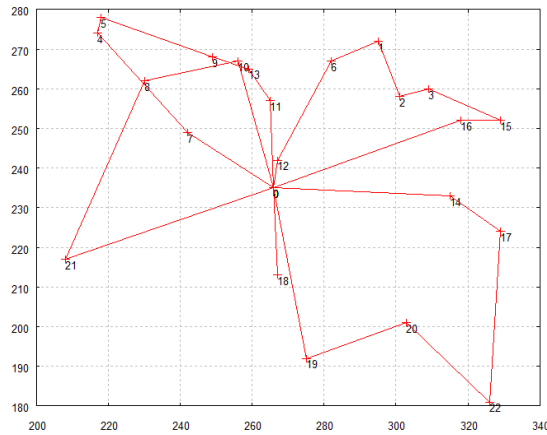

Figure 14: Solution for the instance 08

For each trip, table 10 reports the total items weight, the total item volume and the trip cost.

Trip number	Trip weight	Trip volume	Trip cost
1	1925	32861	212.611
2	2725	34932	142.299
3	994	26906	160.881
4	4425	21017	170.821
5	120	11628	44.045
Total solution			730.657

Table 10: trips details

Let us consider the trip 4. It consists in servicing clients 21, 8 and 10. Table 11 gives the list of the boxes for each client, along with their dimensions.

Client 21	Client 8	Client 10
box 1: 24 15 8	box 1: 36 11 13	box 1: 18 11 8
box 2: 13 14 14	box 2: 27 11 17	
	box 3: 34 7 16	

Table 11: list of boxes to pack for each client

A feasible 3PP solution considering those boxes is as follows:

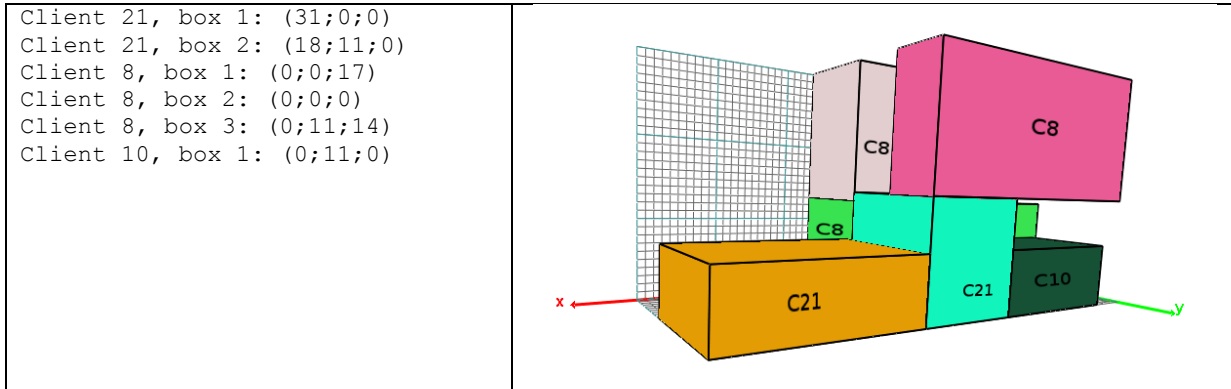

Let us note that a 3D visualization tool can be obtained at <http://www.isima.fr/~toussain/>.

3.5 New benchmarks

Using the GIS system developed by Bajart and Charles [27], shortest paths are computed between cities with more than 100 or 500 citizens for the 96 French counties. The shortest paths are computed using the Google web service and they correspond to the roadmap distance in kilometers between cities. Thus, 96 realistic instances are provided in terms of distances, with size varying from 60 to 255 nodes. To the best of our knowledge, those are the first available instances based on real counties. They can be divided into 4 subsets:

- DLT_3LCVRP_1: 13 small instances with less than 100 nodes;
- DLT_3LCVRP_2: 40 medium instances with 100 to 150 nodes;
- DLT_3LCVRP_3: 33 large instances with 150 to 200 nodes;
- DLT_3LCVRP_4: 11 very large instances with more than 200 nodes.

The results for the 96 instances are available in Appendix 2. Table 12 gives the whole results with rotations allowed. Results without rotations are available at <http://www.isima.fr/~toussain/>

	DLT_3LCVRP_1	DLT_3LCVRP_2	DLT_3LCVRP_3	DLT_3LCVRP_4
\bar{s}	1069.24	2522.99	3936.89	5370.56
\bar{t}	3462.26	4949.80	5220.17	5493.75
s_{best}	1038.20	2457.20	3520.25	4424.02
t_{best}	3519.08	5148.23	5357.04	5532.92

Table 12: GRASP×ELS performance for the new instances

For the classical instances, allowing items rotation slightly improves the results. For this new set of instances, eight instances cannot be solved if rotations are forbidden since the items of some clients cannot be packed with the heuristic we introduced (see Table 13). For one instance, GRASP×ELS found a solution with 16 vehicles while only 15 vehicles are available.

instances	client
DLT_3LCVRP_2b	10
DLT_3LCVRP_12	104
DLT_3LCVRP_09	205
DLT_3LCVRP_21	119
DLT_3LCVRP_30	25
DLT_3LCVRP_40	116
DLT_3LCVRP_49	83
DLT_3LCVRP_50	44

Table 13: Client packing failure with the heuristic if rotations are not allowed

4 Concluding remarks

This article considers an extension of the well-known CVRP in which three dimensional packing constraints must be addressed in each trip servicing clients. This problem deals with two combinatorial optimization problems: vehicle routing and three-dimensional packing. The method we propose compete with the best published methods but the method is currently dedicated to the 3L-CVRP with no extra constraints. It is based on an original resolution of the 3PP based on a dedicated heuristic for the vehicle loading resolution. We are currently investigating the 3L-CVRP with additional constraints, trying to extend the original 3D-packing scheme we introduce.

References

- [1] Baldacci R., Battarra M. and Vigo D. Routing a Heterogeneous Fleet of Vehicles. In: *The Vehicle Routing Problem: Latest Advances and New Challenges*, Golden B. and Wasil E. (Eds). 2008, 3-27.
- [2] Toth P. and Vigo D. An overview of vehicle routing problems. in: *The Vehicle Routing Problem*, Toth P and Vigo D. (Eds). SIAM Monographs on Discrete Mathematics and Applications, Philadelphia, 2002, 1-26.
- [3] Prins C. Two memetic algorithms for heterogeneous fleet vehicle routing problems. *Engineering Applications of Artificial Intelligence*, 2009, 22: 916-928.
- [4] Cordeau J.F., Gendreau M., Hertz A., Laporte G. and Sormany J.S. New heuristics for the vehicle routing problem. In: *Logistic systems: design and optimization*, A. Langevin and D. Riopel (eds.), Wiley, New York, 2005, 279-298.
- [5] Gendreau M., Iori M., Laporte G. and Martello S. A Tabu Search Heuristic for the Vehicle Routing Problem with Two-Dimensional Loading Constraints, *Networks*, 2008, 51(1): 4-18.
- [6] Zachariadis E.E, Tarantilis C.D. and Kiranoudis C. A guided Tabu Search for the Vehicle Routing Problem with two dimensional loading constraints, *European Journal of Operational Research*, 2009, 3(16): 729-743.
- [7] Fuellerer G., Doerner K.F., Hartl R.F. and Iori M. Ant colony optimization for the two-dimensional loading vehicle routing problem, *Computers and Operations Research*, 2009, 36(3): 655-673.
- [8] Iori M., Salazar González J.J. and Vigo D. An exact approach for capacitated vehicle routing problems with two-dimensional loading constraints, *Transportation Science*, 2007, 41(2), 253–264.
- [9] Duhamel C., Lacomme P., Quilliot A. and Toussaint H. A multi-start evolutionary local search for the two-dimensional loading capacitated vehicle routing problem, *Computers & Operations Research*, 2011, 38(3): 617-640.
- [10] Gendreau M., Iori M., Laporte G. and Martello S. A Tabu Search Algorithm for a Routing and Container Loading Problem. *Transportation Science*, 2006, 40 (3): 342-350.
- [11] Fuellerer G., Doerner K.F., Hartl R.F. and Iori M. Metaheuristics for vehicle routing problems with three-dimensional loading constraints, *European Journal of Operational Research*, 2010, 201(3): 751-759.

- [12] Hifi M., Kacem I., Nègre S. and Wu L. A Linear Programming Approach for the Three-Dimensional Bin-Packing Problem. *Electronic Notes in Discrete Mathematics*, 2010, 36: 993-1000.
- [13] Wu Y., Li W., Goh M. and de Souza R. Three-dimensional bin packing problem with variable bin height. *European Journal of Operational Research*, 2010, 202(2): 347-355.
- [14] Bortfeldt A. and Mack D. A heuristic for the three-dimensional strip packing problem. *European Journal of Operational Research*, 2007, 183(3): 1267-1279.
- [15] Allen S.D., Burke E.K. and Kendall G. A hybrid placement strategy for the three-dimensional strip packing problem, *European Journal of Operational Research*, 2011, 209(3): 219-227.
- [16] De Almeida A. and Figueiredo M.B. A particular approach for the Three-dimensional Packing Problem with additional constraints, *Computers & Operations Research*, 2010, 37(11): 1968-1976.
- [17] Prins C. A GRASP×Evolutionary Local Search Hybrid for the Vehicle Routing Problem, in: Pereira F.B. and Tavares J. (Eds). *Bio-inspired Algorithms for the Vehicle Routing Problem*, Studies in Computational Intelligence, publisher Springer, Berlin, 2009, 161: 35–53.
- [18] Feo T.A. and Resende M.G.C. Greedy randomized adaptive search procedures, *Journal of Global Optimization*, 1995, 6: 109–33.
- [19] Prins C. A simple and effective evolutionary algorithm for the vehicle routing problem, *Computers and Operations Research*, 2004, 31: 1985–2002.
- [20] Lourenço H., Martin O. and Stützle T. Iterated Local Search. In: Glover F. and Kochenberger G. (Eds). *Handbook of Metaheuristics*. Springer New York, 2003, 57: 320-353.
- [21] Duhamel C., Lacomme P. and Prodhon C. Efficient frameworks for greedy split and new depth first search split procedures for routing problems, *Computers & Operations Research*, 2011; 38(4):723-739.
- [22] Gilmore P.C. and Gomory R.E. Multistage cutting stock problems of two and more dimensions, *Operations Research*, 1965: 13: 94–120.
- [23] Guibas L.J. and R. Sedgwick. A Dichromatic Framework for Balanced Trees, 19th Annual Symposium on Foundations of Computer Science, Ann Arbor, Michigan, 16-18 October, 1978: 8-21.
- [24] Bayer R. and E.M. McCreight. Organization and Maintenance of Large Ordered Indices. *Acta Informatica* 1972; 1: 173-189.
- [25] Lacomme P., Prins C. and Ramdane-Chérif W. Competitive Memetic Algorithms for Arc Routing Problems, *Annals of Operations Research*, 2004, 131: 159-185.
- [26] Beasley J.E. Route-first cluster-second methods for vehicle routing, *Omega*, 1983, 11: 403–408.
- [27] Bajart V. and Charles C. Systèmes d'Information Géographique. 3rd year project report, ISIMA. <http://www.isima.fr/~lacomme/students.html>, 2009.

Appendix 1

instance	(Gendreau et al., 2006)		(Fuellerer et al., 2010)		GRASP×ELS			
	\bar{s}	\bar{t}	\bar{s}	\bar{t}	\bar{s}	\bar{t}	s_{best}	t_{best}
01	297.65	3.40	297.65	1.00	297.65	3.53	297.65	0.0
02	334.96	0.60	334.96	0.10	335.67	0.06	334.96	0.0
03	362.27	448.10	362.27	16.20	362.27	13.99	362.27	0.2
04	430.89	11.10	430.89	0.50	430.88	0.40	430.88	0.0
05	395.64	0.50	406.50	9.60	379.43	8.16	379.43	0.1
06	495.85	14.70	495.85	1.20	495.85	0.30	495.85	0.0
07	742.23	1.80	732.52	18.10	725.43	237.39	725.43	4.9
08	735.14	104.90	735.14	13.30	735.14	36.63	735.14	1.1
09	630.13	977.80	630.13	3.70	630.13	2.18	630.13	0.1
10	717.90	410.70	711.45	92.60	687.57	589.11	687.57	32.1
11	718.24	208.10	718.25	81.90	718.24	1453.35	718.24	1.8
12	614.60	1 302.70	612.63	7.50	610.05	19.66	610.00	2.0
13	2 316.56	2 317.30	2391.77	174.50	2306.04	1242.44	2306.04	86.9
14	1 276.60	2 121.30	1222.17	425.90	1186.96	2423.64	1184.44	3600.2
15	1 196.55	2 916.14	1182.86	645.00	1161.20	2144.72	1161.11	689.3
16	698.61	863.00	698.61	2.80	698.61	2.87	698.61	0.0
17	906.42	753.20	862.18	3.10	861.80	8.58	861.79	1.2
18	1 124.33	2198.90	1112.18	1484.60	1084.26	1893.69	1078.41	2030.8
19	680.29	1 390.30	671.60	414.40	670.44	3322.67	658.34	3429.6
20	529.00	7 007.50	515.39	1436.70	510.95	2892.97	503.30	1469.7
21	1 004.40	6 262.50	951.87	2105.70	943.05	4173.74	921.25	4697.4
22	1 068.96	2 078.70	1030.12	1218.40	1029.87	3561.80	1009.45	3348.3
23	1 012.51	4 314.10	971.05	1231.70	987.06	3120.66	976.46	1889.1
24	1 063.61	1 052.50	1057.39	184.70	1056.33	2610.20	1047.75	682.8
25	1 371.32	500.90	1207.97	3986.10	1232.73	4489.01	1219.77	4658.4
26	1 557.12	1 075.00	1453.39	2843.60	1415.15	3484.63	1393.76	3066.6
27	1 378.52	3 983.20	1333.16	2208.30	1317.38	3372.87	1304.82	2422.3
Avg. Cost	876.31		856.67		847.04		841.96	
Avg. Time		1567.4		689.3		1522.56		1189.44
Avg. Norm. Time		1504.1		689.3		1004.89		785.03

Table A1: Solution values (rotations allowed)

instance	GRASP×ELS				GRASP×ELS			
	\bar{s}	\bar{t}	s_{best}	t_{best}	\bar{s}	\bar{t}	s_{best}	t_{best}
	Rotations allowed				Rotations forbidden			
01	297.65	3.53	297.65	0.0	297.65	1.01	297.65	0.0
02	335.67	0.06	334.96	0.0	335.67	0.06	334.96	0.0
03	362.27	13.99	362.27	0.2	362.27	5.31	362.27	0.2
04	430.88	0.40	430.88	0.0	430.88	0.19	430.88	0.0
05	379.43	8.16	379.43	0.1	379.43	1.56	379.43	0.0
06	495.85	0.30	495.85	0.0	495.85	0.34	495.85	0.0
07	725.43	237.39	725.43	4.9	732.51	104.85	732.51	0.1
08	735.14	36.63	735.14	1.1	730.66	115.78	730.66	0.1
09	630.13	2.18	630.13	0.1	633.72	2.52	633.72	0.1
10	687.57	589.11	687.57	32.1	704.97	1009.19	704.64	34.2
11	718.24	1453.35	718.24	1.8	718.24	225.10	718.24	13.6
12	610.05	19.66	610.00	2.0	610.00	11.62	610.00	2.7
13	2306.04	1242.44	2306.04	86.9	2299.05	111.17	2299.05	3.9
14	1186.96	2423.64	1184.44	3600.2	1194.57	2966.97	1192.29	612.0
15	1161.20	2144.72	1161.11	689.3	1163.34	1975.90	1163.23	1050.3
16	698.61	2.87	698.61	0.0	700.80	1.20	700.80	0.1
17	861.80	8.58	861.79	1.2	861.79	7.69	861.79	2.2
18	1084.26	1893.69	1078.41	2030.8	1091.61	2502.66	1091.28	4137.8
19	670.44	3322.67	658.34	3429.6	665.45	2489.16	662.96	1810.9
20	510.95	2892.97	503.30	1469.7	515.95	2340.49	513.28	3166.3
21	943.05	4173.74	921.25	4697.4	947.30	2503.90	940.72	2945.8
22	1029.87	3561.80	1009.45	3348.3	1039.64	2249.58	1021.02	3552.4
23	987.06	3120.66	976.46	1889.1	980.63	2194.71	972.12	3146.3
24	1056.33	2610.20	1047.75	682.8	1053.60	3964.98	1048.55	3697.1
25	1232.73	4489.01	1219.77	4658.4	1224.56	2898.75	1209.81	2564.6
26	1415.15	3484.63	1393.76	3066.6	1427.58	3053.36	1421.35	4711.4
27	1317.38	3372.87	1304.82	2422.3	1322.02	2449.77	1298.84	3617.4
Avg. Cost	847.04		841.96		848.88		845.48	
Avg. Time		1522.56		1189.44		1229.18		1298.87

Table A2: Solution values (with and without rotations)

Appendix 2

		GRASP×ELS			
		\bar{s}	\bar{t}	s_{best}	t_{best}
DLT_3LCVRP_01	Ain	1461.63	5361.81	1388.27	5418.4
DLT_3LCVRP_08	Ardennes	1065.51	2764.31	1041.54	2461.0
DLT_3LCVRP_10	Aube	1232.45	3685.94	1200.33	2580.6
DLT_3LCVRP_11	Aude	1565.7	4491.45	1517.85	4854.3
DLT_3LCVRP_36	Indre	2085.69	4594.17	2042.01	5324.0
DLT_3LCVRP_39	Jura	1828.25	4174.64	1758.5	5076.3
DLT_3LCVRP_43	Haute Loire	1361.26	4117.87	1317.93	5301.0
DLT_3LCVRP_52	Haute Marne	1176.91	3635.08	1146.78	2618.0
DLT_3LCVRP_55	Meuse	1103.22	2458.72	1078.8	1526.2
DLT_3LCVRP_70	Haute Saone	1328.27	3777.12	1289.68	5052.7
DLT_3LCVRP_75	Paris	71.6	78.82	71.6	1.3
DLT_3LCVRP_82	Tarn et Garonne	1027.84	3704.84	1006.8	5135.5
DLT_3LCVRP_92	Haut de Seine	256.88	2454.46	254.56	133.4
DLT_3LCVRP_93	Seine saint denis	219.44	3020.38	216.35	4722.1
DLT_3LCVRP_94	Val de Marne	254.01	3614.27	242.04	2581.4
Average		1069.24	3462.26	1038.20	3519.08

Table A3: GRASP×ELS performances on French counties ($n \leq 100$)

		GRASP×ELS			
		\bar{s}	\bar{t}	S_{best}	t_{best}
DLT_3LCVRP_03	Allier	2139.75	4603.22	2052.27	5330.8
DLT_3LCVRP_05	Hautes Alpes	2075.94	5099.58	2026.35	5430.4
DLT_3LCVRP_06	Alpes Maritimes	3529.92	4613.60	3444.20	4476.5
DLT_3LCVRP_07	Ardeche	2484.92	4229.79	2434.31	4389.0
DLT_3LCVRP_12	Aveyron	2329.36	4804.46	2268.78	4844.2
DLT_3LCVRP_13	Bouches du Rhone	2352.33	4739.08	2296.61	4062.9
DLT_3LCVRP_16	Charentes	1932.30	5141.70	1872.63	5180.4
DLT_3LCVRP_17	Charentes Maritimes	1978.44	3841.00	1929.74	4671.5
DLT_3LCVRP_2A	Corse du Sud	2864.00	4926.72	2821.78	4917.4
DLT_3LCVRP_2B	Haute Corse	3735.49	3626.75	3665.83	4552.5
DLT_3LCVRP_21	Cote d'Or	1977.07	5353.86	1885.21	5375.1
DLT_3LCVRP_25	Doubs	3266.13	5246.27	3159.12	5429.8
DLT_3LCVRP_26	Drome	2700.61	4845.18	2648.82	5409.2
DLT_3LCVRP_28	Eure et loire	2935.09	5322.84	2832.90	5414.4
DLT_3LCVRP_30	Gard	3538.71	5335.48	3436.54	5424.6
DLT_3LCVRP_31	Haute Garonne	1818.05	4705.95	1776.06	4792.8
DLT_3LCVRP_34	Herault	2765.50	4951.93	2736.49	5347.4
DLT_3LCVRP_40	Landes	3990.96	5308.65	3912.77	5438.5
DLT_3LCVRP_41	Loir et Cher	2852.58	5370.68	2759.98	5400.7
DLT_3LCVRP_47	Lot et Garonne	1809.77	5289.63	1778.14	5402.5
DLT_3LCVRP_48	Lozère	2961.16	4719.93	2875.28	5407.1
DLT_3LCVRP_51	Marne	2367.75	5259.18	2217.50	5400.4
DLT_3LCVRP_53	Mayenne	1564.51	4675.93	1528.12	5440.7
DLT_3LCVRP_60	Oise	2256.10	5100.09	2231.22	5300.0
DLT_3LCVRP_61	Orne	2022.89	4310.26	1954.09	5309.2
DLT_3LCVRP_66	Pyrénées Orientales	2916.57	5229.04	2872.76	5470.1
DLT_3LCVRP_68	Haut Rhin	2109.04	5279.39	2042.68	5038.4
DLT_3LCVRP_73	Savoie	3163.53	4655.41	3085.56	5188.6
DLT_3LCVRP_74	Haute Savoie	3499.17	5096.06	3442.30	5427.2
DLT_3LCVRP_79	Deux Sèvres	3156.48	5283.64	3077.39	4672.8
DLT_3LCVRP_81	Tarn	2159.38	5321.56	2097.33	5390.7
DLT_3LCVRP_83	Var	2882.99	5376.17	2811.55	4558.9
DLT_3LCVRP_84	Vaucluse	1720.03	5283.00	1662.31	5384.2
DLT_3LCVRP_85	Vendée	2449.78	5038.93	2361.79	5557.1
DLT_3LCVRP_87	Haute Vienne	1540.89	5400.42	1498.54	5404.8
DLT_3LCVRP_88	Vosges	3005.10	5075.91	2919.94	5317.4
DLT_3LCVRP_89	Yonne	2362.85	5354.09	2314.52	5400.0
DLT_3LCVRP_90	Territoire de Belfort	658.54	4277.14	642.05	4674.6
Average		2522.99	4949.80	2457.20	5148.23

Table A4: GRASP×ELS performances on French counties ($100 < n \leq 150$)

		GRASP×ELS			
		\bar{s}	\bar{t}	S_{best}	t_{best}
DLT_3LCVRP_02	Aisne	3483.94	5376.81	3411.68	5407.4
DLT_3LCVRP_04	Alpes Hautes Provence	4001.26	5413.66	3898.77	5479.7
DLT_3LCVRP_09	Ariege	3660.89	3677.88	3457.07	5416.9
DLT_3LCVRP_14	Calvados	3404.01	5424.41	3341.09	5535.1
DLT_3LCVRP_15	Cantal	4692.26	5177.38	4597.80	5426.0
DLT_3LCVRP_24	Dordogne	5368.17	5323.03	5261.64	5274.6
DLT_3LCVRP_29	Finistère	5499.76	5070.86	5249.17	5425.4
DLT_3LCVRP_33	Gironde	4173.51	5537.61	4112.79	5700.6
DLT_3LCVRP_35	Illes et Vilaine	2746.49	5198.73	2680.55	5404.7
DLT_3LCVRP_37	Indre et Loire	3244.50	5231.54	3178.33	5232.7
DLT_3LCVRP_42	Loire	4126.93	5340.25	4007.88	5598.0
DLT_3LCVRP_44	Loire Atlantique	3614.01	5290.52	3513.68	5484.1
DLT_3LCVRP_45	Loiret	3243.62	5303.97	3208.11	5552.8
DLT_3LCVRP_50	Manche	6216.28	5369.54	6084.57	5458.6
DLT_3LCVRP_54	Meurthe et Moselle	3888.63	5372.69	3810.19	5476.1
DLT_3LCVRP_56	Morbihan	4415.26	5294.84	4347.93	5405.4
DLT_3LCVRP_57	Moselle	4710.03	5341.14	4599.94	5535.2
DLT_3LCVRP_59	Nord	3124.63	5538.69	3069.32	5422.7
DLT_3LCVRP_63	Puy de Dome	3655.75	5281.63	3569.56	5430.4
DLT_3LCVRP_64	Pyrénées Atlantique	4137.24	5100.74	4077.55	5044.2
DLT_3LCVRP_67	Bas Rhin	2266.82	5072.56	2201.15	4696.7
DLT_3LCVRP_69	Rhone	2056.44	5114.28	2031.52	4472.4
DLT_3LCVRP_71	Saone et Loire	14494.27	5390.60	4093.28	5378.3
DLT_3LCVRP_72	Sarthe	2632.41	5234.74	2548.62	5456.2
DLT_3LCVRP_76	Seine Maritime	3057.31	4985.63	2977.96	5159.4
DLT_3LCVRP_77	Seine et Marne	2754.45	5086.19	2705.95	5424.8
DLT_3LCVRP_78	Yvelines	2744.03	5489.90	2671.51	5244.6
DLT_3LCVRP_80	Sommes	2481.82	5349.43	2407.48	5555.6
DLT_3LCVRP_86	Vienne	4012.49	5069.05	3962.59	5418.2
DLT_3LCVRP_91	Essonne	2227.53	5114.22	2181.66	5231.5
DLT_3LCVRP_95	Val d'Oise	1908.77	5252.83	1868.38	5319.8
Average		3936.89	5220.17	3520.25	5357.04

Table A4: GRASP×ELS performances on French counties ($150 < n \leq 200$)

		GRASP×ELS			
		\bar{s}	\bar{t}	s_{best}	t_{best}
DLT_3LCVRP_18	Cher	4612.07	5464.63	4557.44	5463.3
DLT_3LCVRP_19	Corrèze	5255.32	5436.26	5081.43	5485.2
DLT_3LCVRP_22	Cote d'Armor	4654.87	5563.20	4522.52	5666.8
DLT_3LCVRP_23	Creuse	3237.73	5379.35	3161.36	5403.6
DLT_3LCVRP_27	Eure	3775.79	5366.59	3652.64	5450.0
DLT_3LCVRP_32	Gers	4479.75	5527.63	4414.94	5477.3
DLT_3LCVRP_38	Isère	5482.05	5468.13	5313.02	5598.1
DLT_3LCVRP_46	Lot	5317.21	5625.37	5170.43	5532.8
DLT_3LCVRP_49	Maine et Loire	5968.21	5660.49	5832.03	5619.2
DLT_3LCVRP_58	Nièvre	4016.08	5540.16	3905.81	5791.7
DLT_3LCVRP_62	Pas de Calais	4593.95	5480.41	4484.43	5336.7
DLT_3LCVRP_65	Hautes Pyrénées	13053.68	5412.83	2992.35	5570.3
Average		5370.56	5493.75	4424.03	5532.92

Table A4: GRASP×ELS performances on French counties ($n \geq 200$)