



HAL
open science

Experimental Measurement of Electric Conductivity and Activation Energy in Congruent Lithium Niobate Crystal

Bachir Chikh-Bled, Boumédiene Benyoucef, Michel Aillerie

► **To cite this version:**

Bachir Chikh-Bled, Boumédiene Benyoucef, Michel Aillerie. Experimental Measurement of Electric Conductivity and Activation Energy in Congruent Lithium Niobate Crystal. *Journal of Active and Passive Electronic Devices*, 2012, 7 (3), pp.261-270. hal-00699509

HAL Id: hal-00699509

<https://hal.science/hal-00699509>

Submitted on 21 May 2012

HAL is a multi-disciplinary open access archive for the deposit and dissemination of scientific research documents, whether they are published or not. The documents may come from teaching and research institutions in France or abroad, or from public or private research centers.

L'archive ouverte pluridisciplinaire **HAL**, est destinée au dépôt et à la diffusion de documents scientifiques de niveau recherche, publiés ou non, émanant des établissements d'enseignement et de recherche français ou étrangers, des laboratoires publics ou privés.

Experimental Measurement of Electric Conductivity and Activation Energy in Congruent Lithium Niobate Crystal

BACHIR CHIKH-BLED¹, BOUMÉDIÈNE BENYOUCEF¹ AND
MICHEL AILLERIE²

¹*URMER, Unité de Recherche Matériaux et Energies Renouvelables, University
Abou Bakr Belkaid, Faculty of Sciences, B.P 119, 13000 Tlemcen, Algeria*

²*LMOPS, Laboratoire Matériaux Optiques Photonique et Systèmes, University
Paul Verlaine of Metz and Supelec, 2 rue E. Belin, 57070 Metz, France*

Dielectric conductivity of congruent lithium niobate (LiNbO_3 , LN) crystals was characterized by the classical method using a guard electrode on one face of the sample. The dielectric characterizations of samples are performed by current-tension measurements in the 160–300°C temperature range. The activation energy of LN crystals is deduced by calculation from the obtained characterization experimental results. The method presented in this paper doesn't constitute a novelty itself but the overall process yielding to the determination of the activation energy of LN is originally presented, started from sample preparation to the final calculation and modeling.

Keywords: Lithium niobate, volumic resistivity, electrical conductivity, activation energy.

INTRODUCTION

Electric conductivity is one of the most delicate physical properties to characterize in insulating materials like lithium niobate (LiNbO_3 , LN) due to the weakness of the current and the size generally small of the samples to be characterized [1,2]. Measurements of weak currents can be prone to many sources of errors yielding a poor accuracy in the electrical parameters or property values that the experimenter is seeking. Usually, techniques

*Corresponding author: bachikhbled@yahoo.fr

performed for these measurements require samples with large surface, S and low thickness, e to achieve a high S/e ratio and a high value for the applied electric field. Thus and if the optogeometric shape of the crystal allows the feasibility of such a process, specific preparation of samples with an initial phase during which the deposit of particular electrodes have to be made.

The electrical conduction phenomena in LN single crystals was mainly investigated by means of conductivity studies above room temperature and the dielectric properties of LiNbO_3 was investigated by Bernal *et al.* at a fixed frequency [3] and by Xue *et al.* as function of the composition [4].

Either in the dark or under illumination in usual conditions, *i.e.* from room temperature up to far from the phase transition one, and for photoconduction measurement in the visible and near IR ranges using a beam power density below those generating an irreversible laser damage in the samples, the charge transport in LN crystals mainly imply conduction phenomena assume by electrons [5]. By else, this conduction presents both surfacic and volumic conductivities, which have to be separate when precise characterizations are involved, as those necessary for the accurate determination of the activation energy. The volumic conductivity is usually determined by using the guard electrode technique allowing the suppression of the surfacic contribution to the currents present in the sample when an electric field is applied on it. The activation energy of a congruent LN crystal, cut and prepare with adequate dimensions for electric measurements was calculated by establishing the evolution of the electric conductivity with the temperature. This was achieved up to 600 K to enhance the conduction phenomena, which is extremely weak in dielectric materials as LN. Thus, the method presented in this paper doesn't constitute a novelty itself but the overall process yielding to the determination of the activation energy of LN is originally presented, started from sample preparation to the final calculation and modelling. The method presented in this paper can be applied for measurements in various dielectric materials and is not specific for LN samples, presented here as illustration of the process.

EXPERIMENTAL

In a dielectric material, presenting naturally a significant volumic resistance, placed between two electrodes to which one applies a potential difference, the total measured current will be the sum of the current crossing the volume of the sample and the current propagating along the surface of the material. To measure only volumic conductivity, it is necessary to separate both components during experiments and suppress the contribution of the surface conductivity. For this in the past, the electrode guard technique has been developed to separate these both contributions during measurements. The method is based on the used of a special geometry of the electrodes, schematically

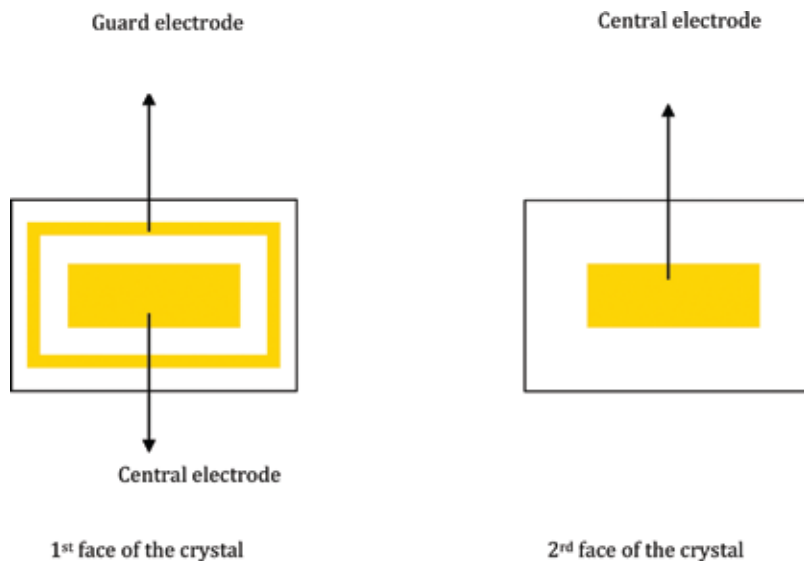

FIGURE 1
Geometrical configuration of the electrodes on the sample under test.

represented in Fig. 1 obtained by adding a guard electrode to the two mains necessary for the volumic contribution measurements.

Within this technique, two electrodes are placed in the center on opposite faces of the sample, separate by a distance corresponding to the thickness, e , of the sample under test, hypothesis was done that electrode are deposited directly onto the sample surfaces avoiding an air gap between sample and electrode. A third electrode, named guard electrode is surrounding one of them on one face only. The central electrodes have to be the largest as possible to activate conduction phenomena in an area into the sample with the widest available surface S , yielding a highest as possible S/e ratio. For measurements, the guard electrode is short circuit with the central electrode placed at the opposite face and connected to a potential voltage used as reference during all the experiments. Within this particular electrical geometry, the surface resistance of the material can be considered as infinite and thus the surfacic current equal to zero. It results that the electrical current crossing in the volume between the two central electrodes corresponds only to the volumic current passing from an electrode to the other.

To optimize the electrode deposition, we suggest a technical protocol using a solution based on laser cutting, which allows an accurate dimensioning of the electrodes, thus a well defined minimum gap between guard and the central electrodes on face one and a precise positioning of all of them on both faces of the sample. Pictures of the experimental setups allowing this



FIGURE 2

Preparation of the sample under test: a. Laser cutting machine, b. Vacuum chamber for gold deposition.

procedure are reported in Fig. 2, with Fig. 2.a the vacuum chamber for gold deposition and Fig. 2.b., the laser cutting machine.

On the two faces of the crystal, we stuck adhesive tape. After designing the electrode shapes, reporting in the laser cutting machine controller software, the adhesive tape surfaces corresponding to the electrodes are put off.

The sample is then put in the chamber of an evaporating bench allowing the deposition of gold in vacuum by evaporation process. The electrodes remain on the sample at the non masking positions by the adhesive tape. Typical thickness of gold onto the sample needed for this kind of measurements is in the order of 200nm insuring stable and permanent electrodes in spite of manipulations.

ELECTRIC CONDUCTIVITY MEASUREMENTS

As mentioned in the introduction, electric conductivity measurements in dielectric material is done as function of the temperature above room temperature. In the experiments, as the sample support, we have chosen a ceramic plate on which the sample is located. The ceramics posses the advantages to resist at high temperatures and to be a very resistive material, but the disadvantage to be difficult for machining. To bring thermal energy to the crystal, the unit carries sample-crystal is placed in a furnace. Accordingly, the setup is represented in Figure 3.

The experiment is controlled by a Source Measurement Unit allowing the measurement of currents in nA to the μA range. The voltage generator is connecting in series with the SMU to the crystal electrodes. On Fig. 4, the furnace and the thermocouple of the type K (for temperature between 10 and 570°C) are also represented.

The resistivity ρ of a material is directly measured following the Ohm law by applying, in the case of a dielectric material a significant voltage to it and

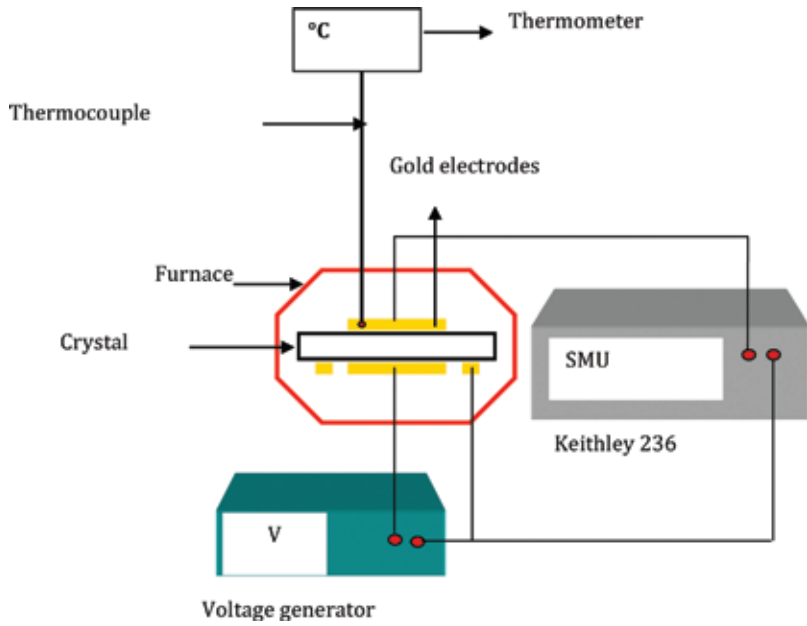

FIGURE 3 Setup measurement performed for volumic dielectric conductivity.

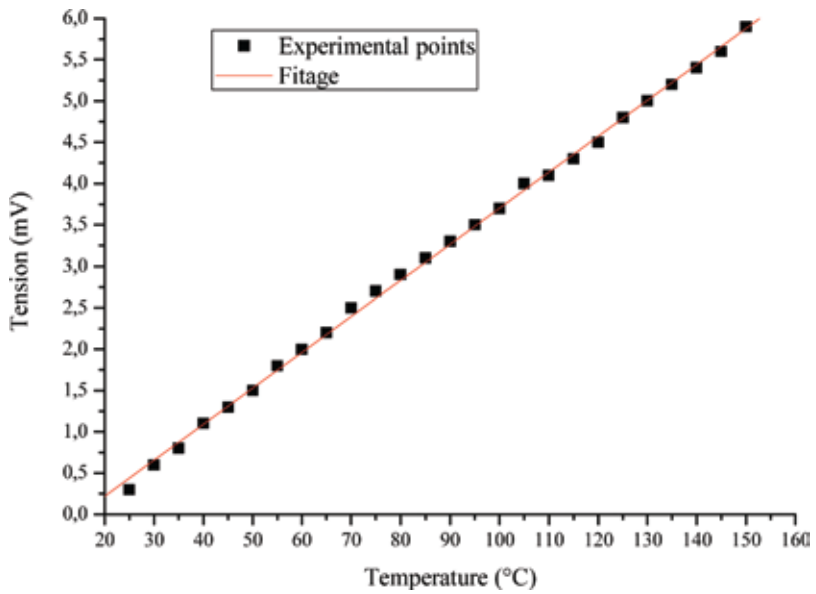

FIGURE 4 Oven calibration: V-T characteristic of the thermocouple up to 160°C.

by a measurement of the resulting current. The following equations, Eqs. 1 and 2 are the basic formula to achieve the photoconductivity σ .

$$\sigma = \frac{1}{\rho} \quad (1)$$

$$\rho = \frac{RS}{e} \Leftrightarrow \rho = \frac{US}{Ie} \Leftrightarrow \sigma = \frac{Ie}{US} \quad (2)$$

with S and e are the surface of the central electrodes and the thickness of the sample, respectively.

For the measurements of volume and surface resistivity of an insulator material and as the current is extremely small in the order of few nanometers even for an application of a high electric voltage, at ambient temperature, the measuring apparatus can not then measure the intensity of the current. Then, the system needs external energy sources to increase electron mobility at a sufficient level for accurate detection via a nano-ammeter. Generally, this additional energy bringing to the material is originate. By thermal agitation, in lithium niobate, the conductive electrons crossing via the conduction band is the main conduction process. Thus, link to the increase of the temperature, the resistance of material decreases, what results in an increase in the electrical current.

EXPERIMENTAL RESULTS

Calibration of the furnace

To carry out the calibration of the setup, the thermocouple is placed in contact with the crystal. In Fig. 5, we plot the voltage-temperature characteristic recorded from ambient up to 160° (with our setup, we have check that the dependence is linear up to 400°). The evolution of the voltage provided by the thermocouple with the temperature is linear, conformed to the properties of thermocouples.

Within this procedure, the furnace is well calibrated.

Electrical conductivity

As predict by theory, no current was detected at low temperature and with our LN crystal between ambient up to 160°C because the thermal contribution of energy and the applied voltage is insufficient for the excitation of the electrons towards the conduction band. Thus measurements were taken above 160°C, temperature at which current starts to be detected. The Figure 5 represents measurements of the I-V characteristics, which were carried out on a congruent LN crystal. Voltage is in the 0 and 400V range.

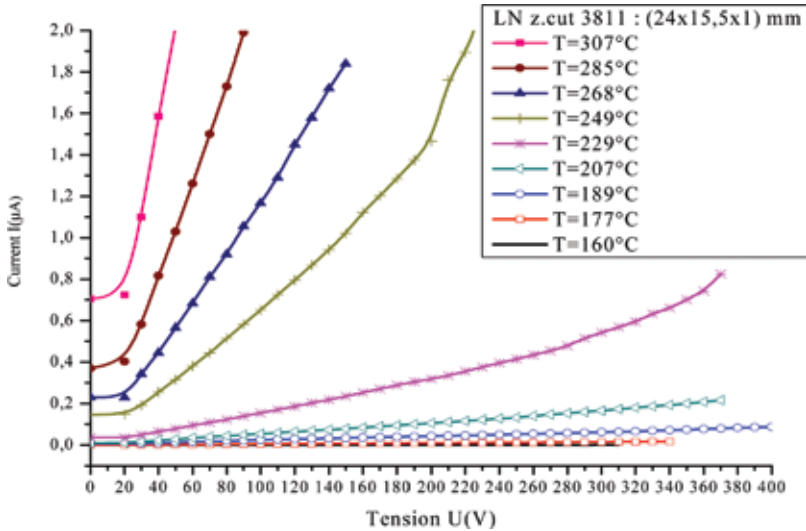

FIGURE 5 I-V characteristics of the LN sample for various temperatures up to 300°C.

Between 160 and 200°C, the behaviour of the current according to the applied voltage is quasi-linear, and on the other hand, above 229°C, one notes a non non-linearity in the I-V behaviour. By else, we clearly show in the 200 to 300°C range that the tension threshold decreases when the temperature increases. This results in the conduction mechanism in which the charge carriers are released by the energy of thermic action.

We represent in Fig. 6 the I-T characteristics for the various applied voltages onto the LN sample. The currents present an exponential behaviour with the temperatures.

The electric conductivity as function of the temperature can be thus calculated with the help of Eq. 2. Results are reported in Fig. 7.

The electric conductivity of dielectric materials obeys to the Arrhenius law [5]:

$$\sigma = \sigma_0 \exp\left(-\frac{E_a}{K_B T}\right) \tag{3}$$

where E_a is the activation energy, K_B , the Boltzmann constant and σ_0 , the pre-exponential factor.

The dependence in temperature of electric conductivity in interval 189 at 300°C is obtained by tracing the logarithm of conductivity according the versus of the temperature [6], from the values of resistances obtained for each temperature, this layout is represented in Fig. 8:

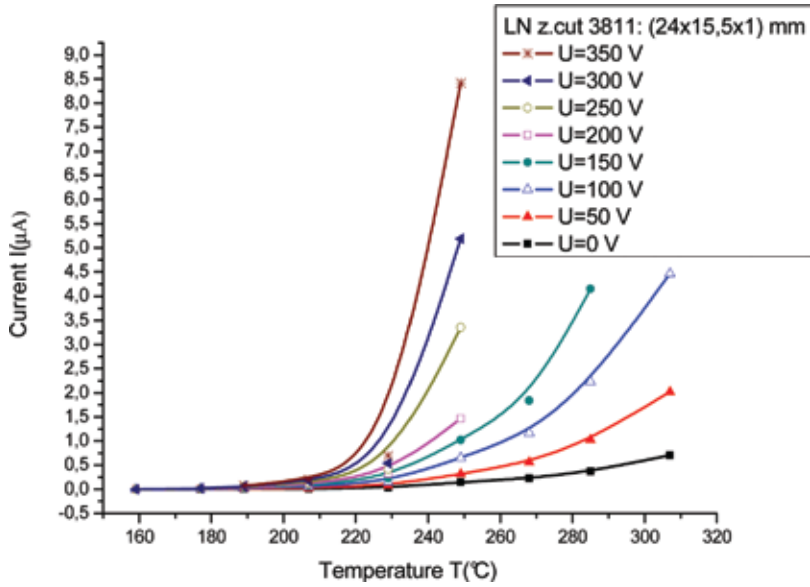

FIGURE 6
I-T characteristics of the LN sample for various applied voltage up to 350V.

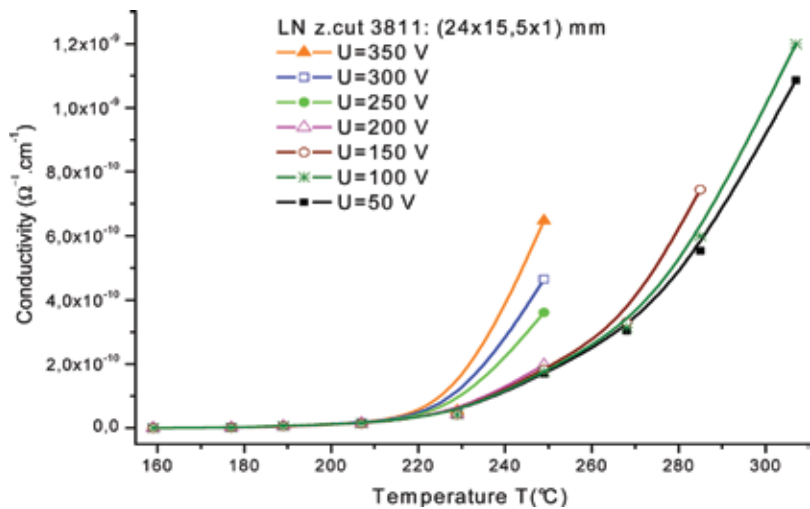

FIGURE 7
Electric conductivity of the LN sample as function of the temperature for various applied voltage.

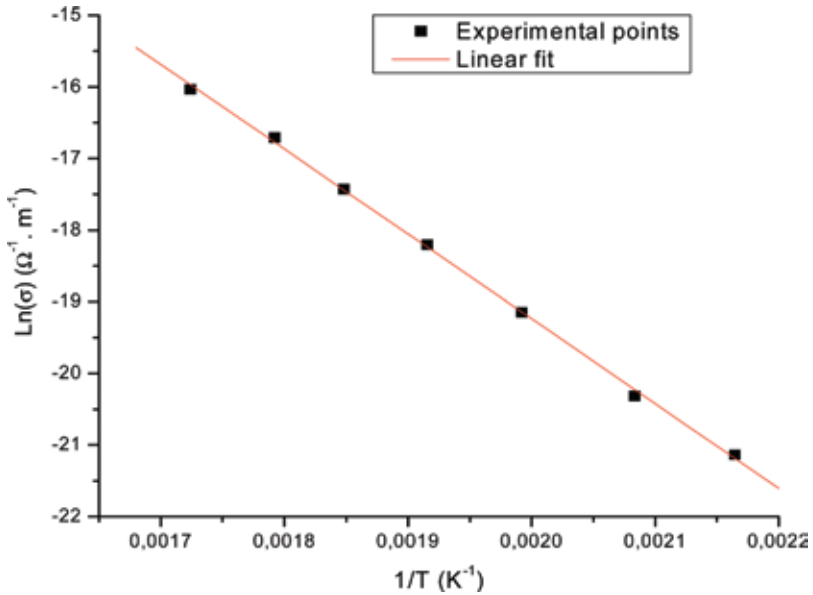

FIGURE 8
Electric conductivity of the LN sample in the 189°-300°C temperature range.

The slope of the graph above enables the determination of the activation energy E_a and within the results of the experiment above, the activation energy in congruent LN crystal is calculated equal to $E_a = 1.031\text{eV}$.

By extrapolation, the electric conductivity at the temperature 600°K of LiNbO_3 is determined equal to $\sigma_0 = 84.864 \Omega^{-1} \cdot \text{cm}^{-1}$. The conductivity of congruent LN crystal is finally calculated and found equal to $\sigma = 2.29 \cdot 10^{-9} \Omega^{-1} \cdot \text{cm}^{-1}$.

We observed a difference between this value and the value given by Mansigh [7] who found for congruent LN crystal $\sigma = 1.99 \cdot 10^{-9} \Omega^{-1} \cdot \text{cm}^{-1}$ corresponding to a discrepancy equal to 14%. This does not show an experimental error, but can be justified by the link of the conductivity with the composition and the nature and the level of the impurities in the crystal. These two material properties present a great influence in all electrical and optical properties of lithium niobate crystals. This is mainly due to the fact that the growing process and the quality of the initial powders hugely influence the quality of the crystal. Congruent lithium niobate crystals present a large amount of intrinsic defect offering large possibilities for impurities to incorporate the crystalline structure, thus modifying the initial crystal composition as predict by the melt composition.

CONCLUSION

Starting from the preparation of the sample to be characterized and the presentation of the experimental setup, we described a complete method allowing the dielectric conductivity characterisation of insulator materials. The method was applied to the determination of the conductivity of a congruent lithium niobate, considered as a reference material in various optoelectronic applications. The technique implemented is the classical method based on the preparation of the sample under test with a guard electrode allowing the determination of only the volumic conductivity. The method, based on the determination of the I-V characteristic was detailed in this study to point out the necessary caution to obtain reliable results. Applied for characterisation of insulator materials, as lithium niobate crystal, we have shown the obligation to provide to the sample an external energy source in the form of a rise in temperature. With a sample placed in an oven at up to 300°C, the electric conductivity and its dependence with the temperature and the activation energy of a congruent lithium niobate were determined.

REFERENCES

- [1] Smith R. T, Welsh F. S. (1971). "Temperature Dependence of the Elastic, Piezoelectric, and Dielectric Constants of Lithium Tantalate and Lithium Niobate", *J. Appl. Phys.*, vol. **42**, pp. 2219–2230.
- [2] Cho Y, Yamanouchi K. (1987). "Nonlinear, elastic, piezoelectric, electrostrictive, and dielectric constants of lithium niobate", *J. Appl. Phys.*, vol. **61**, pp. 875–887.
- [3] Bernal E, Chen G. D, Lee T. C. (1966). "Low frequency electro-optic and dielectric constants of lithium niobate" *Phys. Letters*, vol. **21**, 3, pp. 259–260.
- [4] Xue D, Kitamura K. (2002). "Dielectric characterization of the defect concentration in lithium niobate single crystals", *Solid. State. Com.*, vol. **122**, pp. 537–541.
- [5] Jentjens L, Raeth N. L, K. Peithmann and Maier K. (2011). "Electrical conductivity and asymmetric material changes upon irradiation of Mg-doped lithium niobate crystals with low-mass, high-energy ions", *J. Appl. Phys.* vol. **109**, 124–104.
- [6] Yang Y, Nee I, Buse K, Psaltis D. (2001). "Ionic and electronic dark decay of holograms in LiNbO₃: Fe crystals", *J. Appl. Phys. Lett.*, vol. **78**, pp. 4076–4078.
- [7] Mansingh A. and Dhar A. (1985). "The AC conductivity and dielectric constant of lithium niobate single crystals", *J. Phys. D.*, vol. **18**, pp. 2059–2071.