



HAL
open science

Laboratory synthesis of turbulent boundary layer wall-pressures and the induced vibro-acoustic response

Cédric Maury, Teresa Bravo, Cédric Pinhède

► **To cite this version:**

Cédric Maury, Teresa Bravo, Cédric Pinhède. Laboratory synthesis of turbulent boundary layer wall-pressures and the induced vibro-acoustic response. Acoustics 2012, Apr 2012, Nantes, France. pp.CD-ROM. hal-00696185

HAL Id: hal-00696185

<https://hal.science/hal-00696185>

Submitted on 11 May 2012

HAL is a multi-disciplinary open access archive for the deposit and dissemination of scientific research documents, whether they are published or not. The documents may come from teaching and research institutions in France or abroad, or from public or private research centers.

L'archive ouverte pluridisciplinaire **HAL**, est destinée au dépôt et à la diffusion de documents scientifiques de niveau recherche, publiés ou non, émanant des établissements d'enseignement et de recherche français ou étrangers, des laboratoires publics ou privés.



ACOUSTICS 2012

Laboratory synthesis of turbulent boundary layer wall-pressures and the induced vibro-acoustic response

C. Maury^a and T. Bravo^b

^aEcole Centrale Marseille - LMA, CNRS - LMA, 31 chemin Joseph Aiguier, 13402 Marseille Cedex 20, France

^bCentro de Acustica Aplicada y Evaluacion No Destructiva (CAEND), CSIC - UPM, Serrano 144, 28006 Madrid, Spain
cedric.maury@centrale-marseille.fr

Theoretical and practical feasibility is considered of synthesizing spatially correlated random pressure fields whose statistical properties are similar to that generated by a fully-developed Turbulent Boundary Layer (TBL) over a panel. Laboratory synthesis of TBL excitation would provide a cost-efficient approach, complementary to in-flight or wind-tunnel measurements, in order to test potential solutions to reduce the TBL-induced noise, of relevance within both the aeronautical and surface transport sectors. Of particular interest is the use of a near-field array of suitably driven acoustic sources with an important question: how many uncorrelated sources are required per correlation length to approximate a TBL excitation and the induced vibro-acoustic response? Due to the exponential decay of the spanwise correlation length with frequency, real-time TBL synthesis appears to be only feasible in the low frequency range. However, the structural and radiative filtering properties of the panel dramatically reduces the number of sources required, thus allowing a synthesis of the panel vibro-acoustic response beyond the hydrodynamic coincidence frequency using a reasonable number of sources. Such theoretical findings have been confirmed experimentally. Effective methodologies are also proposed for an accurate reproduction of the TBL-induced sound power radiated by a panel when coupled to a cavity.

1 Introduction

Synthesizing the response of structures to Turbulent Boundary Layer (TBL) wall-pressure fluctuations is a subject of major interest in order to test potential solutions that reduce this source of noise, which is often the most significant in aircraft cabin during cruise conditions. Due to the complexity and cost of these methods, early attempts focussed on the use of reverberant acoustic test facilities to determine the response of aircraft fuselage to an acoustic diffuse field of similar mean-square pressure level. However, this response is very different from the one induced by a TBL, due to the spatial correlation structures of both excitations, that couple differently with the panel modes [1].

In view of these difficulties, scientist and industrials are more and more concerned about the design of cost-efficient test facilities that could directly simulate the characteristics or the effect of TBL wall-pressure fluctuations. Fahy [2] has examined the problem of reproducing the TBL correlation function by means of discrete point force excitation, a single horn loudspeaker, a siren and the far and near field of an air jet. He observed the inability of single acoustic excitations to reproduce the decay characteristics of the TBL correlation function. But he concluded that the required TBL pressure pattern could in theory be approximated using an array of suitably driven shakers. A simulation study by Robert and Sabot [3] assessed the use of a limited number of point force actuators as an alternative to acoustic sources in order to reproduce the vibrating response of a panel induced by a hydrodynamic TBL. They observed that an array of 5 suitably driven actuators were sufficient in principle to reproduce the resonant velocity response induced by a low speed TBL up to 1 kHz with an error less than 1 dB. However, point array forcing experiments are limited when driven to reproduce non-resonant excitation fields such as a TBL or an acoustic diffuse field. Such excitations can however be generated using an array of acoustic sources that produce acoustic waves impinging on the test panel with a range of trace velocities, thus being able to synthesize decaying correlation functions such as the one associated to the statistics of a TBL.

Experimental and simulation studies have been carried out that use an array of near-field loudspeakers driven by optimal signals in order to generate a random pressure field able to reproduce the statistics of the desired wall-pressure fluctuations [4-5]. The methodology has proved to be successful for the laboratory synthesis of an acoustic diffuse field [5-6] and a grazing incident plane wave [5], up

to 1 kHz and 650 Hz, respectively, when using a near-field array of 4×4 loudspeakers. However, for a high speed subsonic TBL, the synthesis technique has shown acceptable accuracy only up to about 200 Hz due to the inability of such a small number of sources to reproduce the exponential decay of the TBL correlation area.

2 Synthesis approach

One considers a near-field array of acoustic sources, driven with signals optimised for the synthesis of a desired random field. It can be associated to the TBL wall-pressure fluctuations, \mathbf{d} , to be reproduced over a grid of regularly spaced microphones located in the proximity to the panel surface, as shown in Figure 1(a), or the velocity response, \mathbf{v} , induced by a given TBL.

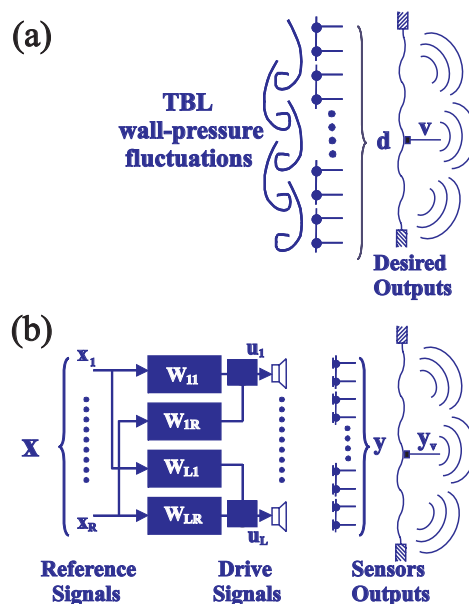

Figure 1: Sketch of a loudspeaker array experiment (b) for the synthesis of TBL wall-pressure fluctuations over a panel or of the TBL-induced panel velocity response (a).

A matrix of control filters, \mathbf{W} , is determined that generates the optimum input signals to the array of loudspeakers, which drive the microphone outputs \mathbf{y} (resp. the outputs of velocity sensors, \mathbf{y}_v), via the plant transfer matrices \mathbf{G} (resp. \mathbf{G}_v), to be statistically equivalent to the target pressure field \mathbf{d} (resp. \mathbf{v}), as seen from Figure 1(b). Minimising in the least-squares sense the vectors of error

signals \mathbf{e} (resp. \mathbf{e}_v) between the desired and generated pressure (resp. velocity) output signals results in the following optimal matrices of control filters [4, 7]:

$$\mathbf{W}_{\text{opt},d} = \mathbf{G}^\dagger \mathbf{D}. \quad (1)$$

$$\mathbf{W}_{\text{opt},v} = (\mathbf{G}_v \mathbf{G})^\dagger \mathbf{G}_v \mathbf{D}. \quad (2)$$

with \mathbf{D} a matrix of shaping filters obtained using an eigen-decomposition of the CSD matrix \mathbf{S}_{dd} of the desired pressure field.

For a TBL, the \mathbf{S}_{dd} matrix is taken from the Corcos model which is particularly well suited to describe the statistics of TBL wall-pressure fluctuations induced by high-speed subsonic flows [8]:

$$S_{dd}(r; \omega) = S_0(\omega) e^{-|r_x|/L_x} e^{-|r_y|/L_y} e^{-j\omega r_y/U_c}. \quad (3)$$

where U_c is the flow convection velocity, L_x and L_y are the correlation lengths along the spanwise and streamwise respectively. They are assumed to be inversely proportional to frequency, and have the form

$$L_x = \frac{\alpha_x U_c}{\omega}, \quad L_y = \frac{\alpha_y U_c}{\omega}, \quad (4)$$

where α_x and α_y are empirical constants taken to be respectively 1.2 and 8.

3 Physical limitations

One considers a typical aircraft aluminium panel of dimensions $l_x \times l_y = 0.328 \text{ m} \times 0.768 \text{ m}$, of thickness $h_p = 0.0016 \text{ m}$, with a damping ratio of 2%, simply-supported along its boundaries, set in a rigid baffle and radiating in free-field. The target random pressures are generated using a near-field array of 3×7 loudspeakers, evenly spaced along the x -spanwise and y -streamwise directions, and separated from the panel by a distance which is about the separation distance between two adjacent loudspeakers [4]. The TBL excitation is reproduced over a grid of 12×28 microphones evenly spaced over the panel surface with a resolution of 0.03 m. The TBL-induced structural (resp. near-field acoustic) responses are simulated over a planar grid of 12×28 velocity sensors (resp. 12×28 near-field microphones located at 0.01 m from the panel radiating side) with a resolution of 0.03 m. Assuming a free-stream velocity of 153 ms^{-1} , the hydrodynamic coincidence frequency range extends up to $f_c = 540 \text{ Hz}$.

From the theoretical criterion of 2.1 acoustic sources per unit spanwise correlation length for the TBL simulation [5], an array of 3×7 loudspeakers is only able to simulate the statistics of the TBL wall-pressure fluctuations up to 91 Hz (resp. 306 Hz) along the panel x - (resp. y -) directions. It can be verified in Figure 2 from the Mean-Square Error (MSE) blue curve, which stays below -5 dB up to 250 Hz. Unlike

the TBL, direct simulation of the panel near-field acoustic response (cyan curve) can be achieved with an acceptable accuracy up to 1 kHz. It closely follows the error reduction related to direct simulation of the panel velocity response (green curve).

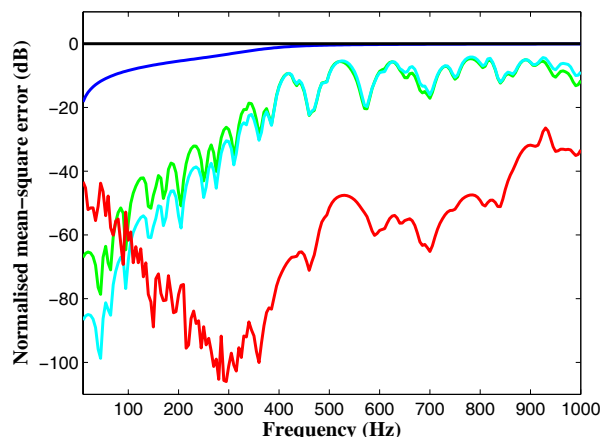

Figure 2: MSEs linked to the simulation of a TBL (blue), and of the panel response (velocity: green ; near-field pressures: cyan ; pressures radiated over a hemisphere: red).

The control filters are clearly able to simulate either the panel velocity response, as from Eq. (2), or the panel acoustic response induced by a TBL. However, in order to reproduce the sound power radiated by the TBL-excited panel, which is a full intrinsic quantifier of the panel vibro-acoustic response, it is *a priori* necessary to simulate both quantities. As one considers a baffled panel radiating in free-field, this can be achieved if the loudspeakers are driven to reproduce the mean-squared pressures radiated over a far-field hemispherical grid of microphones surrounding the panel radiating side, thus encompassing all the panel supersonic radiating components [7]. If the TBL-induced pressures are reproduced over a hemisphere of 20 microphones, it is remarkable to see from Figure 2 that the MSE reduction (red curve) always exceeds 30 dB up to 1 kHz, due to the very small number of sources required for the reproduction of the TBL-induced far-field pressures.

If the radiated pressures due to a TBL are reproduced over the enveloping surface, then the approximate sound power almost coincides with the true TBL-induced sound power, as shown by Figure 3 (red and black curves). It is a direct consequence of an accurate reproduction of the pressures spatial distribution, which closely follows the one due to an ideal TBL, as depicted in Figure 4(d). However, direct simulation of the TBL-induced velocity (resp. near-field pressures) generates a correct approximation to the TBL-induced sound power only below 400 Hz as seen from Figure 3 (green and cyan curves). Finally, the sound power induced when simulating a TBL is well reproduced only up to about 300 Hz, as seen from Figure 3 (blue curve) and from Figure 4(b), with large discrepancies on the hemispherical distribution of the induced radiated pressures. Above 300 Hz, the accuracy of the simulated panel response significantly degrades as the smallest TBL correlation area that can be synthesized with 3×7 sources cannot be lower than 25% of the panel area. It therefore weakly couples with the panel resonant modes which are inefficiently excited by the approximate TBL.

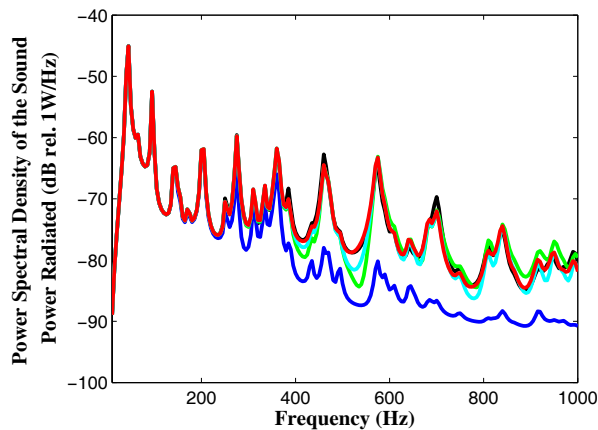

Figure 3: Sound Power radiated due to a TBL (black) and the one generated using 3×7 loudspeakers driven to reproduce a TBL (blue), the velocity response (green), the acoustic response over a near-field grid of 12×28 microphones (cyan) and over a hemisphere of 20 microphones (red).

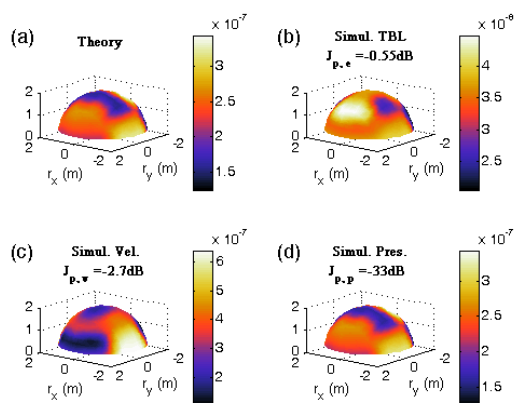

Figure 4: Normalised PSD distribution of the pressures radiated at 970 Hz over a hemispherical grid of 20 microphones assuming perfect reproduction of the TBL (a) and those generated using 3×7 loudspeakers driven to reproduce the TBL (b), the panel velocity response (c) and the panel acoustic response over the hemisphere (d).

It was also observed that reproducing the TBL-induced radiated pressures over the enveloping surface generates a correct backward approximation to the TBL-induced velocity only at low frequencies, i.e. below 400 Hz. The pressure field sensed at the microphones is then governed by the same reduced number of degrees-of-freedom (d.o.f.) than the panel velocity. Above 400 Hz, the panel velocity is overestimated because the control filter is not able to generate a random velocity field with a number of d.o.f. much larger than the one associated to the target far-field radiated pressure. This is due to the radiation impedance matrix which is rank-deficient over this frequency range. A conservative effect induced backward on the velocity is thus observed, as long as the reproduction microphones are able to capture the near-field pressure components, warrant of a "full transmission" of the source components towards the pressure components. It is illustrated in Figure 5 which shows that a reduced set of 3×7 loudspeakers, driven to reproduce the TBL-induced near-field radiated pressures, is

sufficient to provide, here at 275 Hz when the mode (1,6) is resonant and highly excited, a very accurate reproduction of both the near-field acoustic spatial response and the panel velocity distribution, even though it merely achieves a coarse reproduction of the TBL correlation structure with an underestimate of its peak value by about 30%. Experimental TBL synthesis results performed over a baffled clamped panel set in a semi-anechoic environment have confirmed these findings [7].

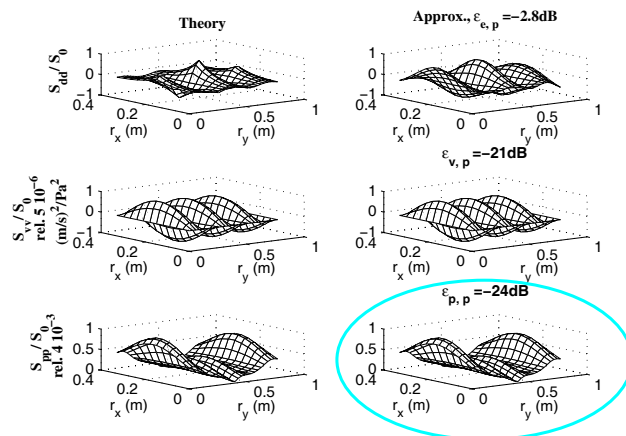

Figure 5: Spatial correlation structures at 275 Hz associated with the excitation (top) and with the panel structural and acoustic responses (resp. middle and bottom), when perfect reproduction of a TBL is assumed (left) and that of the approximate (right) generated using 3×7 loudspeakers driven to reproduce the near-field panel acoustic response over a planar grid of 12×28 microphones.

4 Synthesis of the TBL-induced pressures transmitted to a cavity

In order to use the proposed methodology in a practical situation, the design of a loudspeaker array experiment for the synthesis of the TBL-induced pressure field should account for the modal influence of the cavity into which the panel radiates (aircraft cabin), which also modifies the panel velocity response, so that a coupled panel-cavity system should be considered for the synthesis approach. A fully coupled modal formulation of a cavity-panel-cavity system had already been developed to better characterize low frequency sound transmission between two rooms when simulating an acoustic diffuse field over a panel [6]. One strategy would be to equalize the panel-cavity response in order to reproduce at points inside the cavity the TBL-induced pressure, but the optimum matrix of control filters would then become dependent on the specific configuration of the receiving room under use, and may not be able to properly equalize the weakly damped cavity resonances.

Another methodology is proposed in this work so that the optimum drive signals only depend on the loudspeakers array acoustical environment and on the test panel. A first step is to calculate an optimum matrix of control filters, $\mathbf{W}_{\text{opt},p}$ [similar to Eq. (2)], in order to reproduce over an array of microphones an acoustic pressure as close as possible to the one induced by a TBL and radiated in free-field. A second step is to use these signals to drive the

loudspeakers array in the panel-cavity configuration in order to calculate the TBL-induced response in the real environment to be controlled. The optimal loudspeaker signals are then independent on the particular cavity coupled to the radiating structure, so that they only depend on the aircraft panel considered.

Figure 6 shows prediction results for the sound power radiated by the aircraft panel in a cavity of dimensions $L_x \times L_y \times L_z = 3.14\text{m} \times 3.53\text{m} \times 3.38\text{m}$ and average absorption coefficient 0.2. One observes from the cyan curves that an array of 3×7 loudspeakers, driven to simulate the near-field acoustic pressures induced by a TBL in free-field, is also able to provide up to 1 kHz a vibro-acoustic response of the panel-cavity system, similar to the one induced by the TBL. This is only true up to about 300 Hz if the TBL-induced acoustic pressures are reproduced at the far-field hemispherical microphone positions (red curve). For a given separation distance between the reproduction microphones and the panel, the accuracy degrades at frequencies for which the number of d.o.f. associated to the cavity pressure exceeds the number of d.o.f. of the free-field radiated pressure. A rectangular enclosure has been used here for illustration purposes, but this methodology could be coupled with any modal description of a real cavity, obtained through experimental measurements or numerical analysis, in order to predict the TBL-induced radiated sound pressure or potential energy to be controlled.

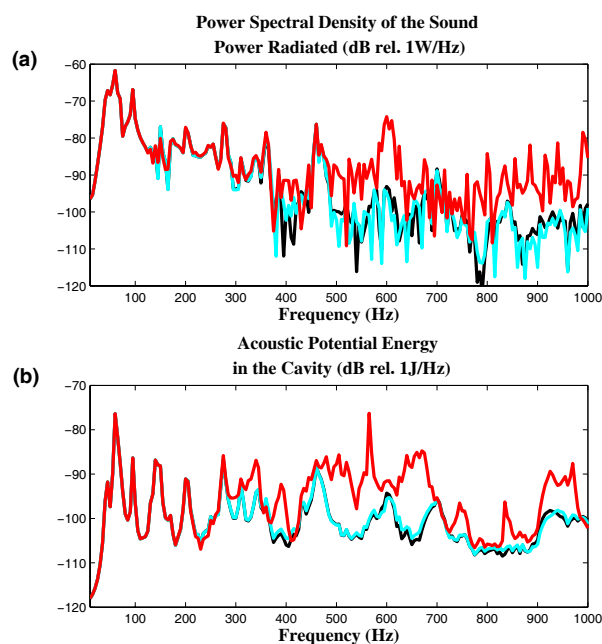

Figure 6: (a) Sound power radiated in a cavity by a panel and (b) cavity potential energy when the panel is subject to a TBL (black) and that generated by 3×7 loudspeakers driven to reproduce the TBL-induced pressures radiated in free-field over a planar grid of 12×28 near-field microphones (cyan) and over a far-field hemisphere of 20 microphones (red) with radius 1.5 m.

5 Conclusion

An experimental methodology has been developed for the laboratory simulation of the vibro-acoustic response of an aircraft panel subject to a TBL using a near-field array of

suitably driven loudspeakers, as a viable alternative to pointwise simulation of the statistics of TBL wall-pressure fluctuations. The number of acoustic sources required to simulate the TBL-induced panel velocity or near-field (resp. far-field) acoustic pressure scales on the mode count of the panel resonances (resp. on the most efficient radiators) up to the hydrodynamic coincidence frequency range. These criteria are much less demanding than the TBL simulation criterion, especially if the TBL-induced far-field response is reproduced. Experimental synthesis of the vibro-acoustic response of a clamped panel induced by a high-speed TBL has been achieved with a good accuracy over the hydrodynamic coincidence frequency range, i.e. up to about 1 kHz, with a reduced set of 4×4 loudspeakers. If the test panel is coupled to a receiving room, it is found that, simulating in the cavity the same near-field acoustic pressures as those radiated in free-field by the TBL-excited panel, is sufficient to provide a correct generation of the TBL-induced pressures in the cavity.

References

- [1] C. Maury, P. Gardonio, and S. J. Elliott, "A wavenumber approach to modelling the response of randomly excited panel, Part I: General theory ; Part II: Application to aircraft panels excited by a turbulent boundary layer," *J. Sound Vib.* 252, 83–113 ; 115–139 (2002)
- [2] F. J. Fahy, "On simulating the transmission through structures of noise from turbulent boundary layer pressure fluctuations," *J. Sound Vib.* 3, 57–81 (1966)
- [3] G. Robert and J. Sabot, "Use of random forces to simulate the vibroacoustic response of a plate excited by a hydrodynamic turbulent boundary layer," *Proceedings of the ASME Winter Meeting: Symposium on Flow-Induced Vibrations*, 5, 53-61 (1984)
- [4] T. Bravo and C. Maury, "The experimental synthesis of random pressure fields: Methodology," *J. Acoust. Soc. Am.* 120, 2702–2711 (2006)
- [5] C. Maury and T. Bravo, "The experimental synthesis of random pressure fields: Practical feasibility," *J. Acoust. Soc. Am.* 120, 2712–2723 (2006)
- [6] T. Bravo and C. Maury, "Enhancing low frequency sound transmission measurements using a synthesis method," *J. Acoust. Soc. Am.* 122, 869-880 (2007)
- [7] T. Bravo and C. Maury, "A synthesis approach for reproducing the response of aircraft panels to a turbulent boundary layer excitation," *J. Acoust. Soc. Am.*, 129, 143-153 (2011)
- [8] G. M. Corcos, "Resolution of pressure in turbulence," *J. Acoust. Soc. Am.* 35, 192–199 (1963)