



HAL
open science

IMS based WLAN/3G convergence and advanced mobility features

Mehdi Mani, Noel Crespi

► **To cite this version:**

Mehdi Mani, Noel Crespi. IMS based WLAN/3G convergence and advanced mobility features. Emerging wireless networks : concepts, techniques and applications, CRC Press, pp.151-185, 2011, 8-1-4398-2135-0. 10.1201/b11420-6 . hal-00690718

HAL Id: hal-00690718

<https://hal.science/hal-00690718>

Submitted on 24 Apr 2012

HAL is a multi-disciplinary open access archive for the deposit and dissemination of scientific research documents, whether they are published or not. The documents may come from teaching and research institutions in France or abroad, or from public or private research centers.

L'archive ouverte pluridisciplinaire **HAL**, est destinée au dépôt et à la diffusion de documents scientifiques de niveau recherche, publiés ou non, émanant des établissements d'enseignement et de recherche français ou étrangers, des laboratoires publics ou privés.

IMS based WLAN/3G Convergence and advanced mobility features

Mehdi Mani and Noel Crespi

Department of Wireless Networks and Multimedia Services

Institut TELECOM SudParis

9 Rue Charles Fourier, 91011, Evry, FRANCE

{mehdi.mani,noel.crespi}@it-sudparis.eu

Abstract

In this paper we define new strategies for WLAN 802.11 and 3G convergence based on the service delivery infra-structure proposed by IMS. These strategies are beyond the 3GPP solutions for WLAN access to the IMS. Our main aim from this convergence is to introduce new services such as session mobility/splitting and intelligent call routing between these two access technologies. To this end, we extend the IMS policy based admission control architecture and adapt it to the different characteristics of these two access technologies. Subsequently, by taking advantage of the IMS infrastructure, we define a mobility server that can provide the sought inter-technology session mobility. This mobility server is able to apply the advanced policy rules for transferring a session from one access technology to the other. We show how this advanced mobility feature can lead to a more efficient resource utilization.

1 Introduction

Based on IEEE WLAN 802.11 protocol, WiFi technology is mainly developed to provide broad-band wireless access to the Internet services. Considering the vast deployment, low installation cost and broadband media of 802.11, providing converged 3G/802.11 services can substantially improve the availability of advanced services for users. In recent years, there have been massive research and proposals for integration of WLAN and 3G infrastructure in network layer [25, 5]. However, service convergence is a service level aspect which is not achieved by integration just in network layer.

The convergence of service delivery platforms of different network technologies is the solution to get rid of disjoint service-specific networks [12]. This is known as *Service Convergence*. Service convergence is a concept beyond of inter-operability of service-specific network technologies. Figure 1 depicts the difference between the concepts of traditional inter-operation

and convergence.

To get the disjoint systems inter-operated, their transport levels should be interconnected, where at signalling level there are the gateways that translate the signalling of one domain in the border of other domain. With inter-operation of disjoint systems, users of different domains become reachable for each other. However, in convergence, a service delivery overlay by using a unified signalling protocol employs communication services over all the access technologies. This allows the users of one domain benefit from the services of the other domain in addition to the inter-operation. Moreover, the combinational Internet/Telecom or Fixed/Mobile services will be feasible in a scalable and standardized approach. The services such as unique fixed/mobile numbering, shared voice-mail, spanning buddy list, content sharing between multiple end-devices, session splitting/merging between/from different access technologies and plenty of other combined services are the examples of new paradigm of services in the multi-technology service convergence.

As SIP is going to be the dominant protocol for IP based communication services and IMS is a service delivery technology which is specified based on SIP, we also consider IMS as the service control overlay technology. This paper concentrates on the convergence of 3G/WiFi technology and deployment of communication services based on IMS over WiFi. In section 2, we introduce new win-win strategies for deployment of IMS in WiFi technology that leads to WiFi/3G convergence. By this convergence we aim to deploy the advanced mobility features such as session mobility/splitting between these two access technologies. In this regard, in section 3, we extend the IMS policy based admission control architecture to be able to handle these kind of session mobility between these two different access technologies. In the current IMS policy based QoS control system [2], hybrid access technologies should obey a unique policy for their resource allocation. Considering that miscellaneous access technologies have different characteristics in medium access strategy and bandwidth, the unique policy leads to inefficient resource utilization [15]. We improve the architecture of IMS policy based resource reservation for multi-access scenarios. Then with the improved architecture, 802.11 WLAN operators are able to define and effectuate their own policies for call admission and resource allocation. In section 4, by taking advantage of IMS infrastructure, we propose the implementation of a mobility server that handle the session mobility/splitting between 3G and 802.11 WLAN. This mobility server will be deployed in application layer and have access to the admission policy of each domain. We show that how by enforcing the proper policies, this kind of session mobility can lead to better utilization of resources in these two network technologies.

2 Strategies for IMS Integration in WiFi

Adoption of IMS as the service control overlay leads to support of advanced telephony services in WiFi domains with a robust and scalable architecture. However, different WiFi operators may choose different strategies to provide IMS services according to their network configuration, capabilities and resources.

One strategy, specified by the 3GPP in [1], is to define the proper interfaces to let the clients to have access to 3G IMS

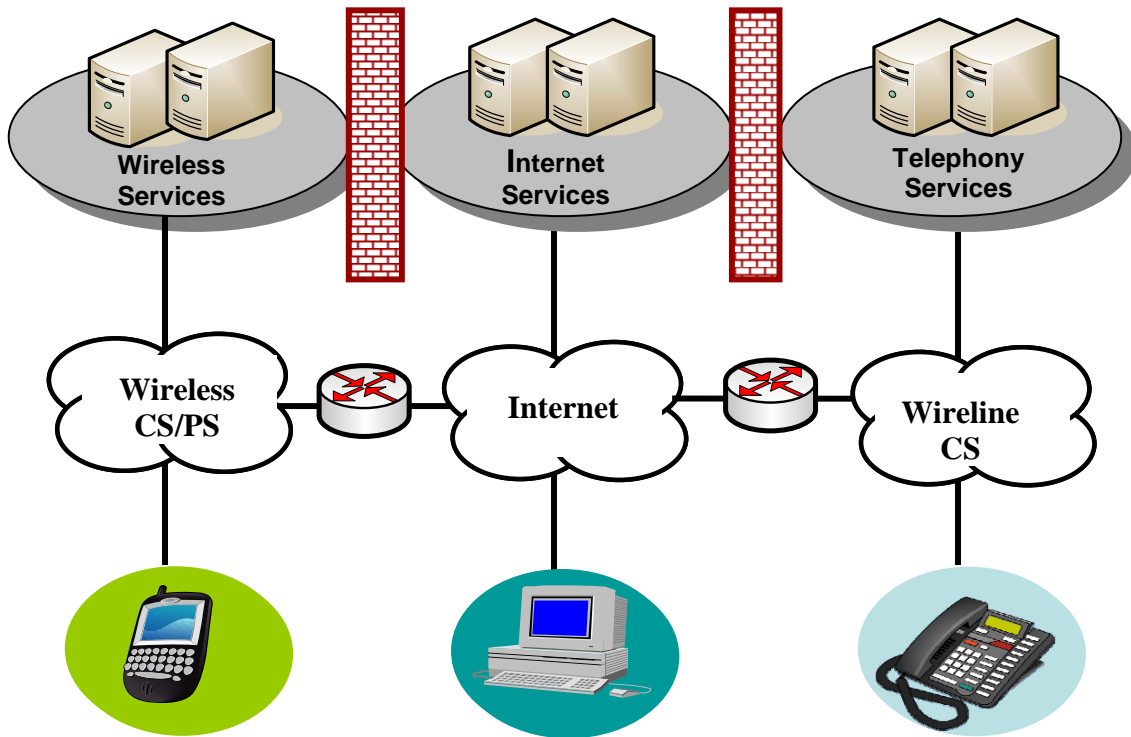

(a) Inter-operation of vertical disjoint service domains

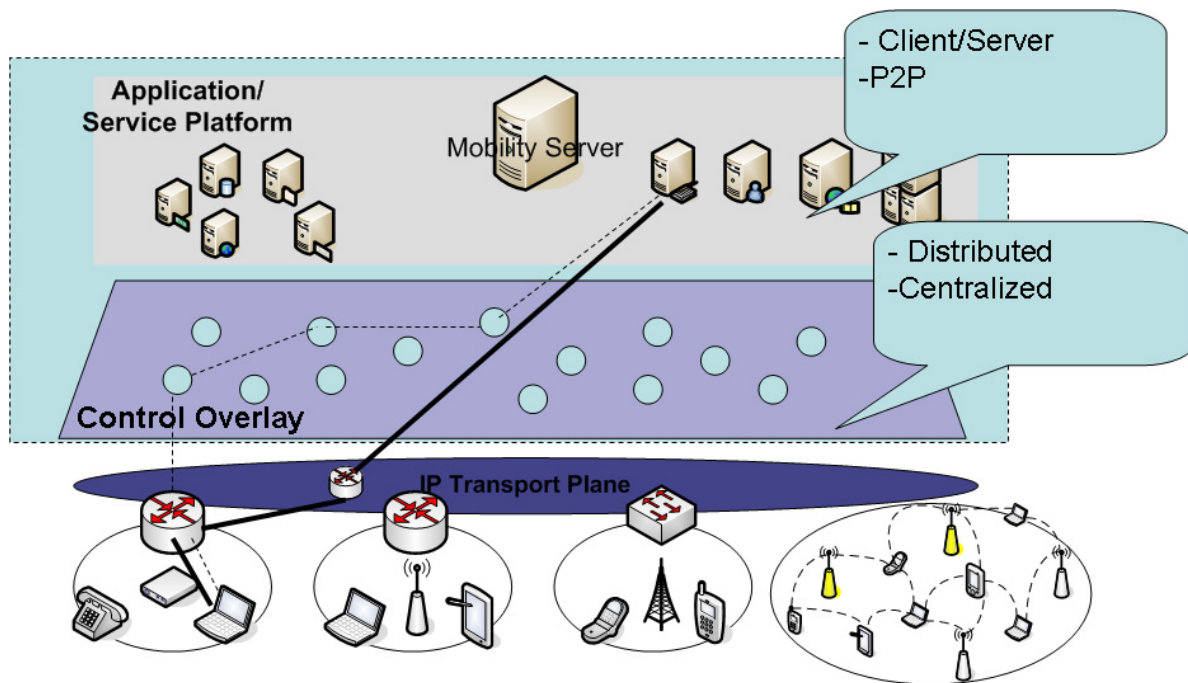

(b) Overlay approach for convergence of multi domains

3
Figure 1. From Inter-operation to Convergence

services via 802.11 WLAN. In such approach, IMS is not deployed in WiFi domain. This strategy introduces a Master-Slave architecture. The 3G operator will be considered as the Master and defines all the required functionality for bearer level inter-connection as well as Authentication Authorization and Accounting (AAA) functionality in service control layer.

2.1 3GPP Approach for access to IMS through WiFi

In Release 6, 3GPP specified an architecture with a Master-Slave model to access the 3G services via WLAN [1]. The

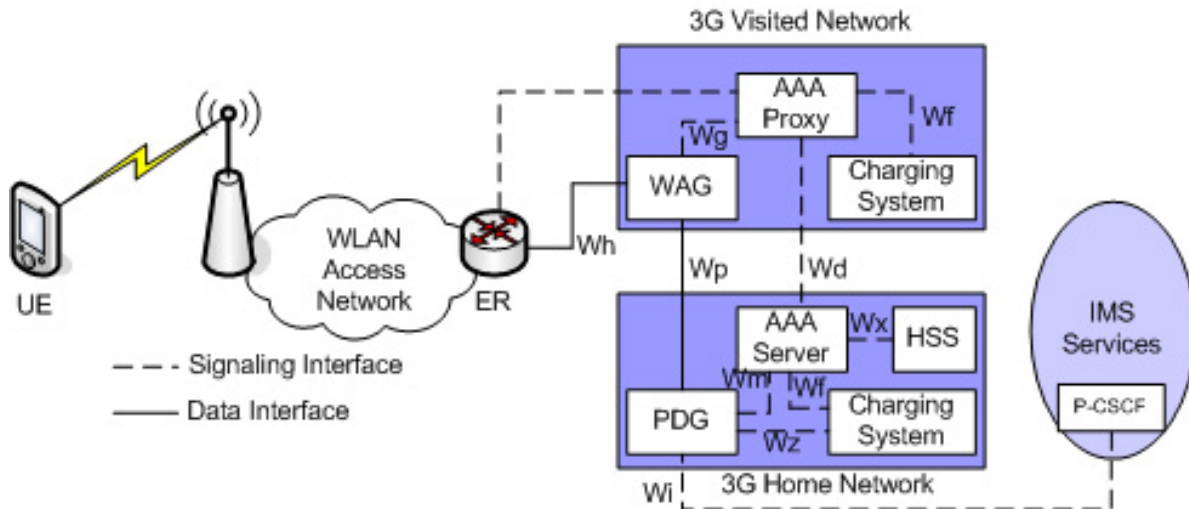

Figure 2. 3GPP Approach for Access to IMS services via WLAN

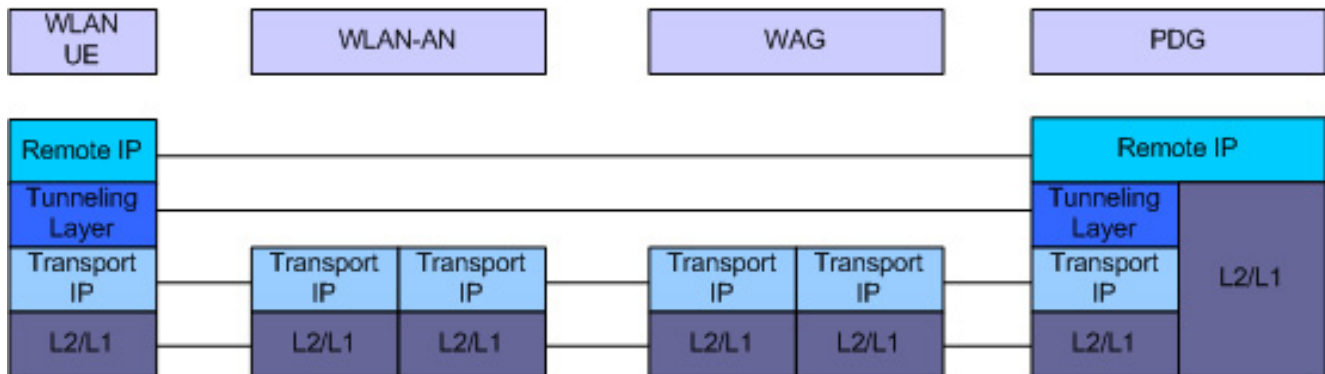

Figure 3. IP Connectivity configuration proposed by 3GPP for WLAN-3G Inter-working

goal of this architecture is to allow the 3G operators to extend their Packet Switched services to the WLAN. These services may include, for example, IMS based services, location based services, Multimedia Broadcast/Multicast Services (MBMS), and any service that is built upon the combination of these components. This architecture is depicted in Fig.2. As shown in this figure, there are four new functional elements that are defined for the purpose of access to 3G services via WLAN [1].

3GPP AAA Server is located in the 3G home domain. It retrieves authentication information and subscriber's profile

from the HLR/HSS for each user and authenticates the users based on the information received from the HLR/HSS. These information are transferred to WLAN for admission control of the users. In addition, this entity provides the charging information.

3GPP AAA Proxy is used in roaming situations and it works as a proxy between UE in the WLAN and the 3GPP AAA Server in the 3G home domain.

In addition to these AAA functional elements, two new elements are also defined at bearer level to create secure connection to 3G domain.

WAG-WLAN Access Gateway is the entry point of the mobile network from the WLAN perspective. In the case of roaming, the UE will be connected to the WAG in the visited network. WAG (either in home or in visited network) forwards the data toward the Packet Data Gateway in home domain. WAG also transfers the bearer level charging information to 3GPP AAA Proxy/Server.

PDG- Packet Data Gateway is the edge router in the 3G home domain that establishes and controls the connection of the user to the external network and services (ie IMS overlay) located in 3G domain. It allocates remote IP (as depicted in Fig.3) to the UE and creates a tunnel between itself and UE in WLAN. Then it maps this tunnel to the external tunnels toward external networks. As shown in Fig.3, it can be noted that two IP layers are represented in this protocol stack. In fact, with such configuration, the PDG can be seen as the last hop router for the UE from the external network view and in addition the 3G Core Network configuration has no impact on the IP connectivity of the UE in WLAN.

Fig.4 shows the complete procedure to setup a session for an IMS service. After access point detection and layer 2/layer 1 attachment, UE starts the authentication process with the AAA server. A successful authentication allows UE to get an IP address routable in WLAN domain. Then, the UE retrieves the IP address of the gateway to 3G domain (PDG) from the local DNS. In next phase, a secure tunnel between UE and PDG is established. This tunnel enables UE to connect to the DHCP server in 3G domain and obtain i) a valid IP address in 3G domain and ii) the address of P-CSCF. After P-CSCF discovering, the normal process of IMS registration and session setup will be followed.

2.2 Going Beyond the 3GPP proposal by adopting IMS in WiFi domain

The 3GPP approach for providing WLAN access to the IMS services is satisfactory for certain operators with specific conditions such as i) the operators that own both of WiFi and 3G access technologies; ii) WiFi operators who do not desire to invest too much for the deployment of IMS on their own domain. However for the WiFi operators who have deployed their own core network and provide vast public WLAN access, this architecture may not be acceptable for several reasons as follow.

First, from the business point of view it is unlikely that such a WiFi operator accepts that all the IMS services reside in the 3G domain. Second, in such a Master-Slave inter-working architecture, all the policies for interconnection are defined by

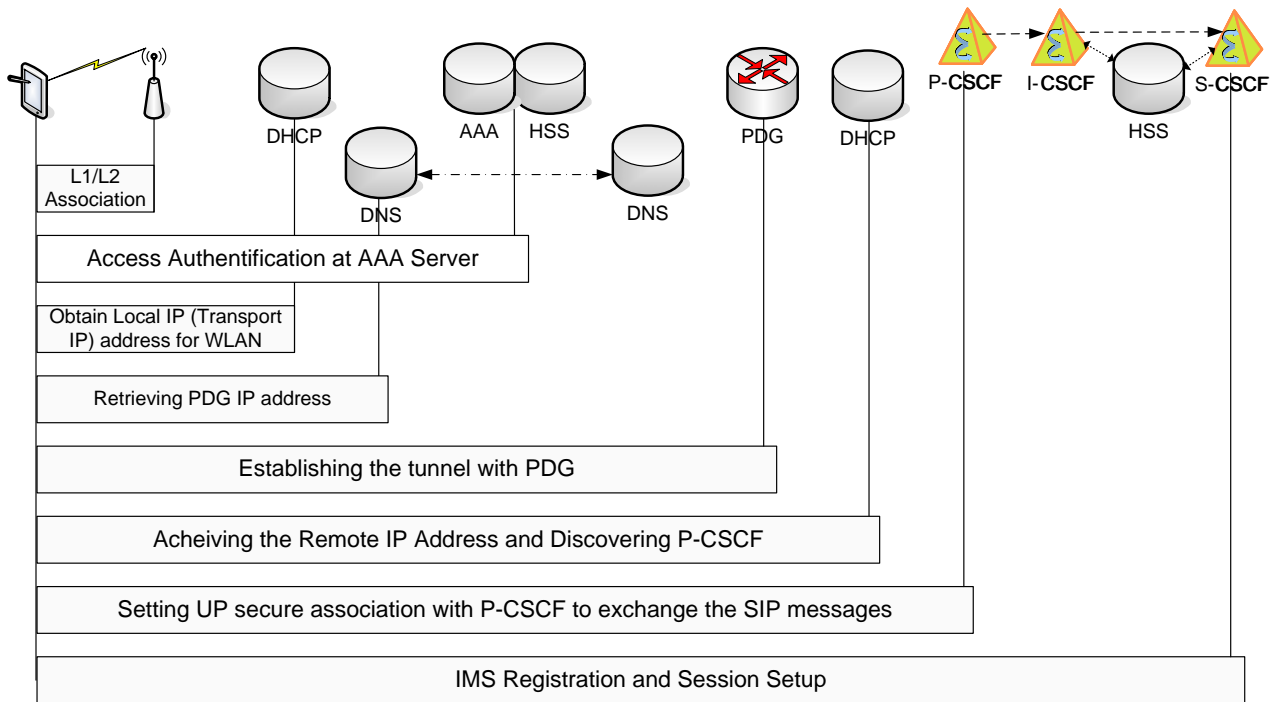

Figure 4. Different Phases of access to IMS Services from WLAN according to 3GPP approach

the 3G operator. Third, the process of setting up the IMS service sessions via WLAN will be so complicated (as depicted in Fig.4). Fourth, the remote IP address that allows the user to be connected to the IMS domain is assigned by the 3G domain. Therefore, if 3G has deployed its IMS based on IPv6 (as what is specified in the standard), the end users in WLAN should support a multi-stack IPv4/IPv6 protocol.

Regarding to these issues, WiFi operators who own enough resources and desire to support IMS services may adopt IMS or an IMS-like architecture as the service overlay in their own domain instead of just being connected to and relying on the 3G IMS. Deployment of IMS in the WiFi network domain leads to horizontal convergence of 3G and WiFi technology. In such architecture, a user may be accessible by a unique number via both of UTRAN and 802.11 access technologies. Moreover, the users of each domain can benefit from the services deployed in other domains.

To deploy the IMS overlay, WiFi operators may choose a step by step and evolutionary strategy to avoid a sudden huge cost for deploying the IMS services. To this end, we have proposed several phases for adopting IMS in WiFi technology. In the first phase, as depicted in Figure 5, the WiFi operators may just implement the functionality of P-CSCF. The P-CSCF will

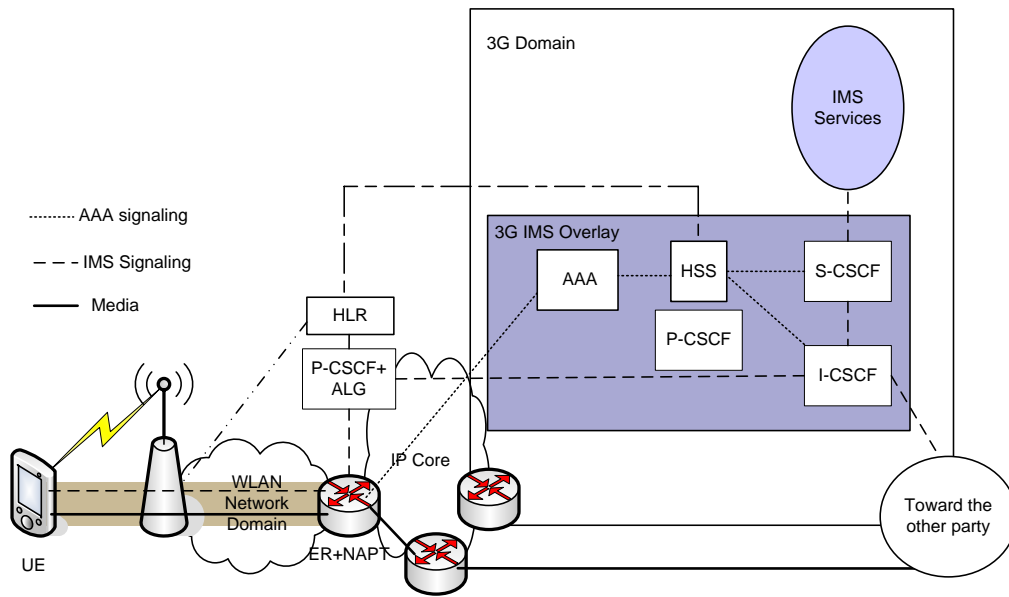

Figure 5. First phase of deploying IMS in WiFi domain

define the security strategy and the compression protocol to reduce the size of SIP messages. For inter-operability with IPv6 domain, NAPT (Network Address/Port Translator) and ALG-Application Level Gateway functionalities are required.

NAPT should be implemented in edge router to replace the IPv4 and IPv6 addresses at the edge of the network in bearer level. ALG (Application Level Gateway) functionality, in this phase of IMS deployment, may be added to P-CSCF. ALG is a STUN [19] or ICE [18] server to resolve the NAT traversal issues in SIP sessions. With such architecture, the end users do not need to support multi protocol stack of IPv4/IPv6 in order to access to IMS services. Moreover, in this approach, there is no need of implementation of PDG and WAG. In fact, the WiFi operator connects its network directly to the network backbone without passing through 3G network. However for session routing, the SIP messages in this phase are still required to be routed via 3G domain.

HLR is also implemented in the WiFi domain and the SSID (service set identifier) will be considered as the attachment point information. SSID is a 32-character unique identifier attached to the header of packets sent over a WLAN that acts as a password when a mobile device tries to connect to the BSS. *BSS- Basic Service Set* is an *access point* (AP) which is connected to the wired network and a set of wireless stations. The SSID differentiates one WLAN from another, so all access points and all devices attempting to connect to a specific WLAN must use the same SSID.

In the next phase of IMS deployment (Fig.6), WiFi operators deploy also both the HSS and I-CSCF. In this phase, WiFi operators will be able to carry out AAA functionalities in their own domain. Therefore the WiFi operator is able to provide

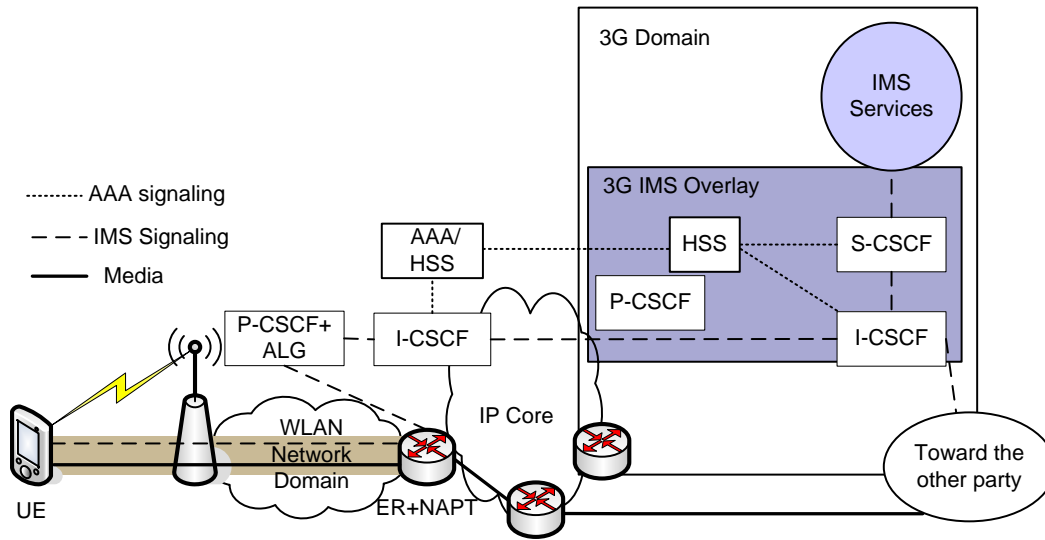

Figure 6. Second phase of deploying IMS in WiFi domain: AAA functionality in WiFi Domain

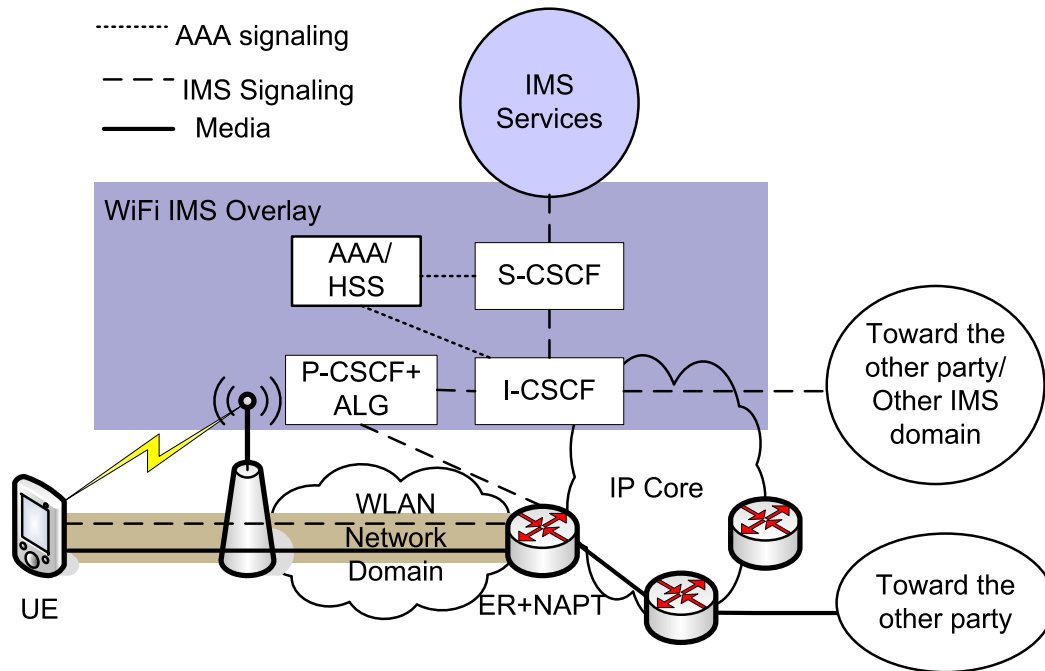

Figure 7. Last phase of deploying IMS in WiFi domain: Complete IMS

Table 1. WLAN and UMTS differences for access to IMS

	WLAN	UMTS
Number of actors in roaming case	Three: WLAN AN, VPLMN and HPLMN	Two: VPLMN and HPLMN
G_o , policy control	This is not defined at all in 3GPP for WLAN accesses	This is defined by 3GPP for UTRAN
Notion of "tunnel for signalling"	No notion of "secondary tunnel" is defined for WLAN Interworking, which means that both signalling and data packets will use the same tunnel	The notion of Secondary PDP Context allows differentiating the PDP Context for signalling and the PDP Context for data
Support of IPv4 necessary on the Local IP layer	IPv4 must be supported on the Local IP layer because many WLAN Access Networks will only support IPv4 in early deployments, as IPv6 must be needed for IMS, this means that the WLAN UE must support the dual stack	The use of IPv6 only is possible as long as the SGSN and GGSN can support it; in such a case, the UE can be based on IPv6 only as far as IMS is concerned

the public and private identification for their clients independent of the 3G operator. I-CSCF interrogates HSS to assign a S-CSCF to the user according to his service criteria. In this phase service triggering functions are carried out in 3G domain, then WiFi is able to add some advance and combinational services to the existing services in 3G domain in order to enrich the existing services for the clients.

Finally, in the last phase as depicted in Fig.7, the IMS overlay will be deployed completely. S-CSCF in WiFi domain localizes the clients when they register for IMS services and invokes the services upon their request. SIP based services will be implemented in this phase in IMS overlay of WiFi domain. In this phase in both of bearer and signaling level WiFi is independent of 3G and can connect to the rest of the network directly.

The step by step IMS deployment provides a smooth migration toward WiFi-with-IMS for the operators. The WiFi operators, according to their strategies and capabilities, may choose one of the proposed architecture.

Finally, it is worth mentioning that there are intrinsic differences in 802.11 WLAN and UTRAN technologies for channel access and resource allocation. In 802.11 technology, access to the channel is contention based and then there is no resource reservation system. Considering the absence of dedicated resources in 802.11, in 3GPP solution for WLAN access to IMS services, resource reservation in WLAN access is just ignored. The differences between WLAN 802.11 and 3G technologies for access to IMS in 3GPP solution is summarized in table 1. In this paper we aim to extend the IMS policy based QoS control system to WiFi. The two main challenges in this way are: i) QoS architectural limitations in IMS; and ii) random access medium of 802.11. The following two sections address these challenges for this integration.

3 Deploying Policy based QoS Control System for 802.11-WLAN

Establishing a flexible and scalable end-to-end QoS control mechanism for Multimedia services in heterogeneous infrastructure of NGN (Figure 1) where access to the services may be achieved via different kinds of wireless-wireline access

technologies such as UTRAN, WLAN, xDSL and Cable is a challenging task. In fact, the current QoS mechanism defined in 3G cannot meet the requirement of such heterogeneous networks in NGN. The current QoS control mechanism introduced in 3G does not allow different domains en route of media-flow to reserve the resources homogeneously. For the same QoS class, different domains dedicate different amount of resources according to their interpretation of that class. This leads to discordant resource reservation in the data flow route.

In this section, we propose the IMS architectural improvement for QoS control to allow different access technologies (including 802.11) to exchange the QoS policies and limitation of their network dynamically and efficiently.

3.1 IMS Policy based QoS Control Architecture

Establishment of sessions for multimedia services like voice or video telephony, video streaming, MMS and Video Conferencing needs co-ordination between bearer and session layer for QoS provisioning. After release 5, with the emergence of IMS, the 3G architecture is a layered architecture with a clean split between transport (eg. SGSN, GGSN), session (eg. P-CSCF, I-CSCF, S-CSCF) and service planes [3]. IMS has introduced a policy based QoS control system.

Providing QoS is not only a transport level issue and the session layer should be involved too. This is why 3GPP has chosen the policy based architecture to provide high quality transport media with efficient resource utilization. In a policy based network, policy rules describe behavior of the network in some high-level statements without going to the detail of network element configurations.

Policy rules are a set of conditions and instructions; whenever a request for a service fulfills a condition, the corresponding instruction will be performed. Figure 8 displays the proposed policy based architecture by IETF [27, 26]. The four major functional entities are defined in this architecture:

Policy Decision Point (PDP): This is logically a centralized entity that makes the policy decision according to the policy rules and the dynamic and static information of the network.

Policy Repository: All the policy rules reside in this entity. Policy Repository is usually implemented inside Policy Decision Point or separately as a LDAP (light-weight directory access protocol) directory server.

Policy Administration System: This is the point in which the operator defines its policies. Policy Administrator System pushes the defined or modified policies to the Policy Repository and informs the PDPs about any modification in policies.

Policy Enforcement Point (PEP): PEPs enforce the policies in the network. They are network elements (especially edge routers) that will realize the policies for the resources by using software and hardware features (scheduling, queuing, classifying, traffic policy and shaping) in the network.

In policy management systems, there are two main models for interaction between PDPs and PEPs: provisioning and outsourcing [26]. In the provisioning model, PDP decides which policy rules should be installed on PEP and then provisions it for the resource reservation request coming to the PEP. In contrast, in the outsourcing model, a resource reservation request

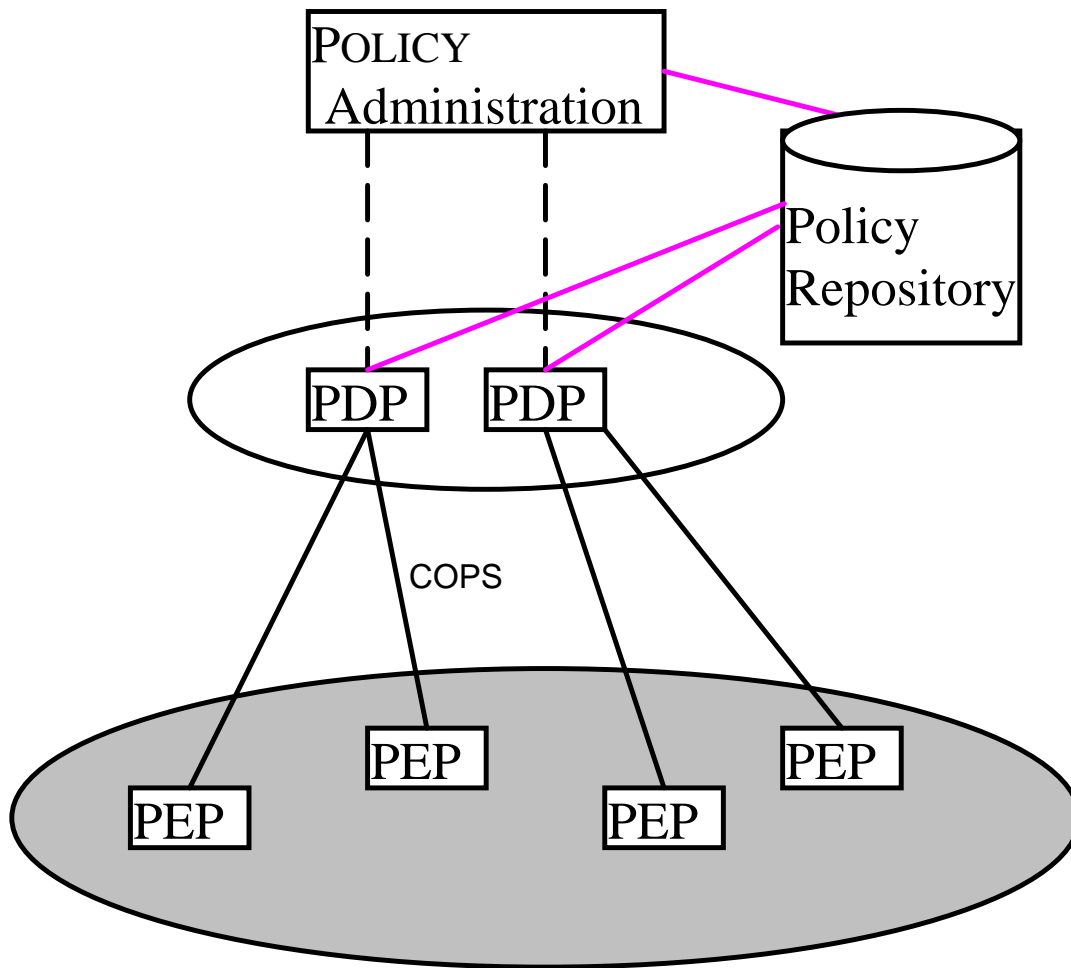

Figure 8. Application Level Policy Based QoS Control Architecture

coming to the PEP will trigger the process of policy request from PDP. Each model has some benefits and disadvantages. For example, the outsourcing model increases the signaling load but it is more adaptive to special cases such as link failure or time-dependent policies.

The policy based architecture defined by IETF is adopted in 3G architecture to establish end-to-end QoS for session based multimedia services. This QoS control system creates coordination between 3G transport level and IMS as the service control overlay.

As the first entry point for a SIP request message (which conveys requested QoS specifications of the service) from a user side, P-CSCF was chosen to host the Policy Decision Function (PDF) in release 5. PDF is equivalent of PDP and enforces the policy rules on the PEP. In the subsequent releases, PDF was introduced as an independent function and the G_q interface was introduced between P-CSCF and PDF. With this revision, other non-SIP based servers are also able to express their session

QoS requirement to the PDF. GGSN as the gateway of data flow to external network acts as the PEP and translate the policy rules to the IP flow control functions (labeling diff-serv flow and traffic classification, scheduling, traffic policy and admission control and traffic shaping). To open a gate for a resource reservation request of a data flow, the PEP component of GGSN must verify the request with PDF in the signaling path. The Go interface makes this co-ordination feasible. 3GPP has agreed on the DIAMETER protocol as the communication protocol on the Go Interface [8].

3.2 IMS QoS Control System Architectural Improvement

The limitations of E2E QoS control of 3GPP can be divided in two categories: 1) QoS Control for multi access technologies; and 2) Inter-domain SLA. In this section, we introduce two new architecture for QoS control in a multi access paradigm and then in section 3.3 we will introduce our solution for Inter-domain SLA.

The current IMS QoS Control architecture allows only a unique set of policy rules to be defined for resource reservation in the whole system. In fact, in the case of access to a service via other access technology, the current architecture only considers the QoS policy of the network where the service is provided. However, in a multi-access paradigm, the QoS signaling and protocol and availability of resources in different technologies may be completely different. For example, in UTRAN (which is the UMTS access technology) the resource reservation is based on Packet Data Protocol (PDP) and it is completely different from 802.11 condition. Hence, the policies defined in another network is very likely inefficient in another technology.

In [6] an architecture similar to what is shown in figure 9 is proposed for multi-access to IMS services. In this architecture, PDF can control the edge routers of different access technologies. Although this architecture improves the 3GPP approach, the solution is limited to the cases where: a) the operators of all access networks are the same or b) there is a big trust between two operators and the access network operator has agreed that the polices be dictated by the core network operator. Such an architecture is not acceptable for horizontal convergence sought in NGN.

To cope with this problem, we have proposed two other architectures which are described in figures 10 and 11. In the architecture of figure 10, the Local PDF (LPDF) will exchange the policies with the PDF in the core IMS and controls the corresponding edge router. On the other hand, in the architecture in figure 11 we have proposed that Local Policy Repositories of each access network will exchange their policies with a shared PDF which we call that S-PDF. The S-PDF will control the edge routers of a certain access technologies in that proximity.

Each architecture has its benefits and drawbacks, and its adoption depends on the policies and capabilities of the access network operators. In the first architecture, for example for SIP based applications P-CSCF as the SIP proxy should be implemented in the access network to transfer the session QoS parameters to the local PDF. This costs more but leads to a more dynamic, scalable and distributed solution. This architecture is more suitable for access networks which have already deployed P-CSCF for their home services. On the other hand, in the architecture of figure 11, there is no need

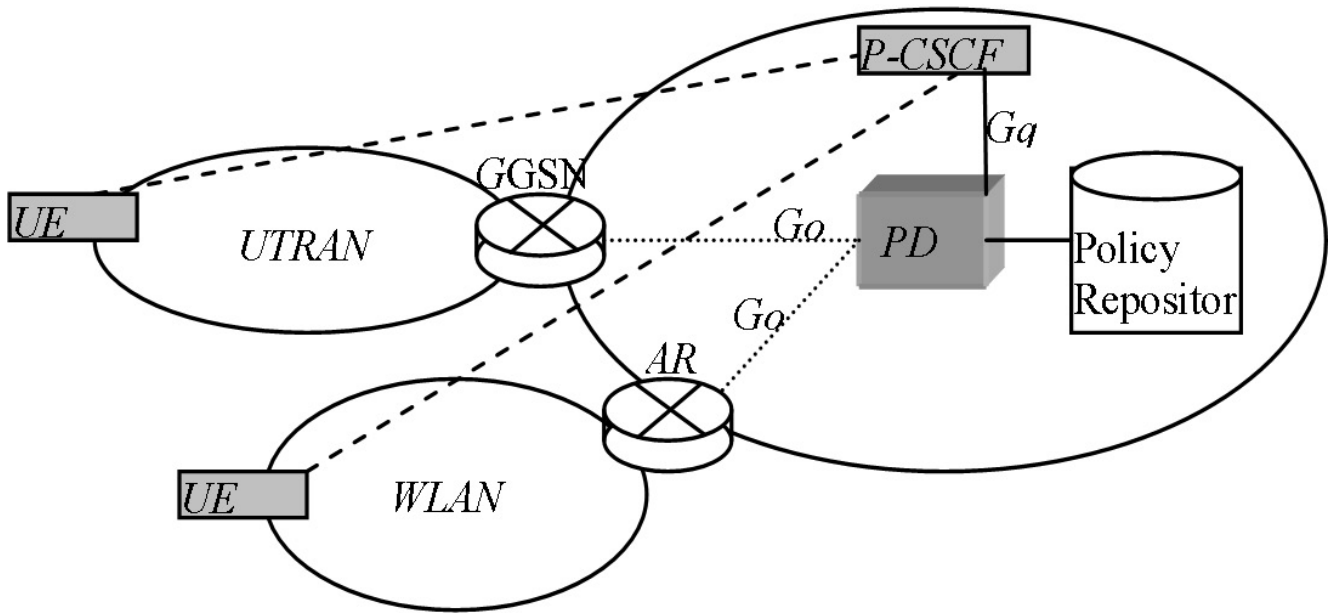

Figure 9. Modified Architecture for Multi Domain E2E QoS : All the Edge/Access routers are controlled by the policies defined in UMTS core network

for deployment of signaling processing elements in the access networks and cost will be decreased. However, the policy exchange can not be as dynamic as the previous architecture and in addition the S-PDF may be the bottleneck of the system. In these two architectures, the policy repositories or PDFs are distributed in the access and core networks of different network technologies/domains. Therefore, all the operators including access and core operators express their policies to be considered for the end-to-end resource reservation and all the domains en route the data flow will reserve their resources with considering the policy of other domains as well as theirs. This leads to homogenous end-to-end resource reservation.

3.2.1 Advanced Policy Definition

In convergent WiFi/3G networks, according to the different capability of these access technologies beside the various requirements of different services (Bandwidth, delay jitter, E2E delay, security etc.), different criteria should be considered for admission policies.

These criteria can be divided into four main categories:

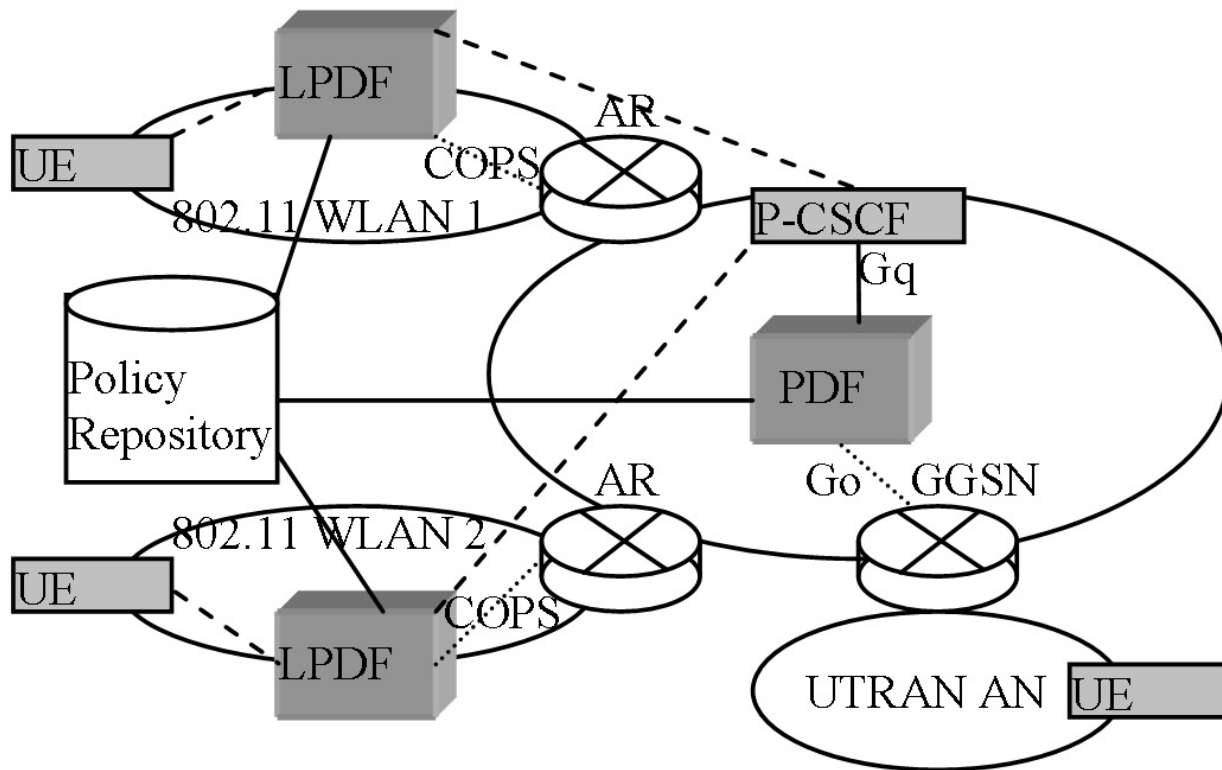

Figure 10. Modified Architecture for Multi Domain E2E QoS : The access networks own their Local PDF to control the AR

- Access network information: Access parameters are, Downstream available bandwidth, upstream available bandwidth, Link quality condition (SNR, PER, retransmission rate), security level and access cost.
- User Preferences: User preferences include, expected QoS level for the service, preferred access point, the priorities that he/she defines for each service etc.
- Terminal Capabilities: User terminal capabilities indicate if it is a multi-mode terminal or not. If yes, which access technologies it supports. The size of the screen, battery life, etc. can be considered as terminal capabilities too.
- Service Type: Each service including VoIP, Video Phoney, Conferencing, web, email, File transferring applications etc. needs different QoS and Security support. Therefore, according to the active sessions of the user, the best candidate access should be selected in Handover time.

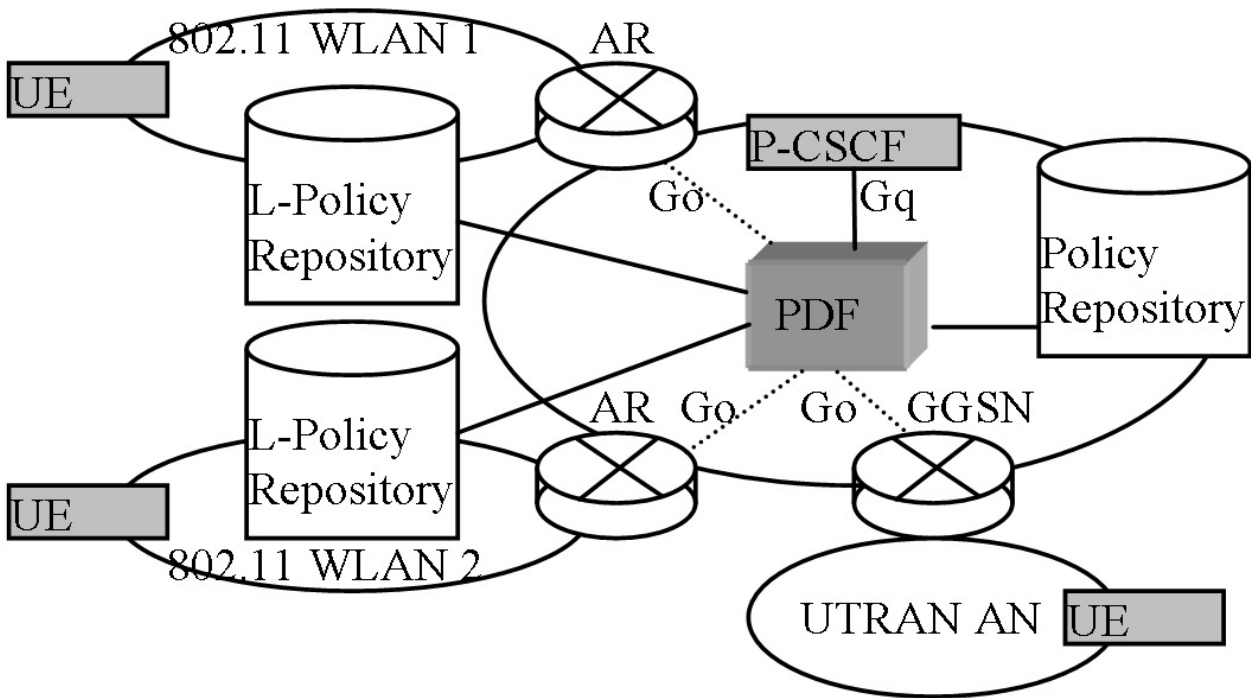

Figure 11. Modified Architecture for Multi Domain E2E QoS : The access networks don't have their Local PDF to control the AR. But defines their policies themselves

3.3 SLA Broker: New actor in converged networks

NGN follows the goal of horizontal convergence of hybrid technology in the infrastructure and service level. Each network domain in converged paradigm should be able to exchange SLA with other network operators and service providers of other domains and technologies. This is very essential because without that, the users of other domains will not benefit from the services of other domains/technologies and this conflicts with the goal of "horizontal" convergence.

The existing QoS control architecture in 3GPP cannot fulfill all of these requirements because each operator need to exchange its SLA with all other operators and technologies directly. However, in the NGN paradigm the number of network operators as well as service providers may be high and then it is not feasible for a domain to exchange directly its SLA with all other operators.

In [20] some mechanisms to exchange dynamic SLA between end-user and service networks are introduced but the solution is not for inter-domain and inter-technology architecture. To enable inter-domain SLA in a scalable manner, we have proposed the architecture of Figure 12 [16]. In our inter-domain SLA model, there is a service provider that enables the service of SLA exchange for all operators in the blended network architecture of NGN. we call this service provider the SLA

broker. The SLA broker may be founded by a consortium of major operators of different technologies. With the existence of SLA broker, each operator defines its policies and SLA for the services it provides and registers them with this SLA broker. Then when the user of one domain requests a service which is hosted in another domain (or in the case of roaming) the SLA broker exchanges the SLA of the involved operators. With such architecture, the operators no longer needs to exchange their SLA with all other operators directly and this leads to scalable architecture for inter-operation of different domains.

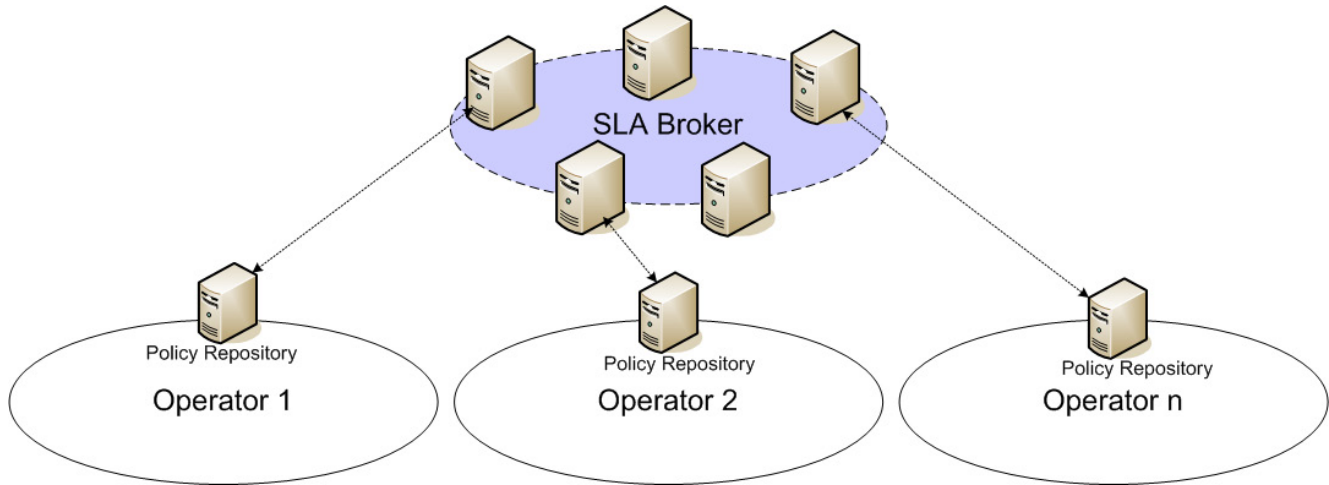

Figure 12. SLA Broker

4 Advanced Mobility Features based on IMS over 802.11/3G

Convergence of 3G and WiFi technologies based on IMS brings in several advanced services including advanced mobility features such as session mobility, session splitting, service mobility and cognitive call routing. In this section we take advantage of IMS service infrastructure and propose the deployment of a mobility server to provide session mobility/splitting over WLAN and 3G access technologies.

The Mobility Server can provide attractive features such as the ability of transferring an active session running on a device to another device connected to another access technology. Session Mobility is one of the aspects of mobility that brings in many advantages including:

- New capabilities for the customers;
- Better utilization of resources and load balancing;
- Higher user satisfaction level;
- Service persistence;

- Leverage frequency and duration of service usage.

4.1 Session Mobility Components

Session mobility is the process of transferring an active session to another terminal or another interface. There are four main components involved in a session mobility process:

- **Triggering Device:** The Triggering Device is the device that triggers the session mobility. In the simplest scenario, Triggering Device is one of the two devices that are currently involved in the active session (caller or callee device). However, in advanced model of session mobility, the Triggering Device is not necessarily one of devices involved in the current session. Triggering Device should just have authorization for this session transfer request.
- **Source Device:** Source Device, is the device involved in the current session whose session will be transferred to another device.
- **Target Device/Interface:** The Target Device/Interface is the device/interface that receives the media after session transfer.
- **Corresponding Device:** The corresponding device is the device of other party of the session that remains unchanged after session mobility.

Session mobility needs the following steps to be completed:

1. Device/Session Discovery.
2. Authentication of the devices.
3. Selecting and authorizing the target device for transfer.
4. Informing the Corresponding Device about new party.
5. Negotiating for the new parameters of the session.
6. Session Migration: Media transferring
7. Session Resume (in the case)

In the Device Discovery process, Triggering Device discovers the legitimate devices whose capabilities match with the requirements in the query for Target Device. The discovered devices all have already authenticated by the system, and non-authenticated devices are not allowed to take part in the discovery process. On the other hand, session discovery is required

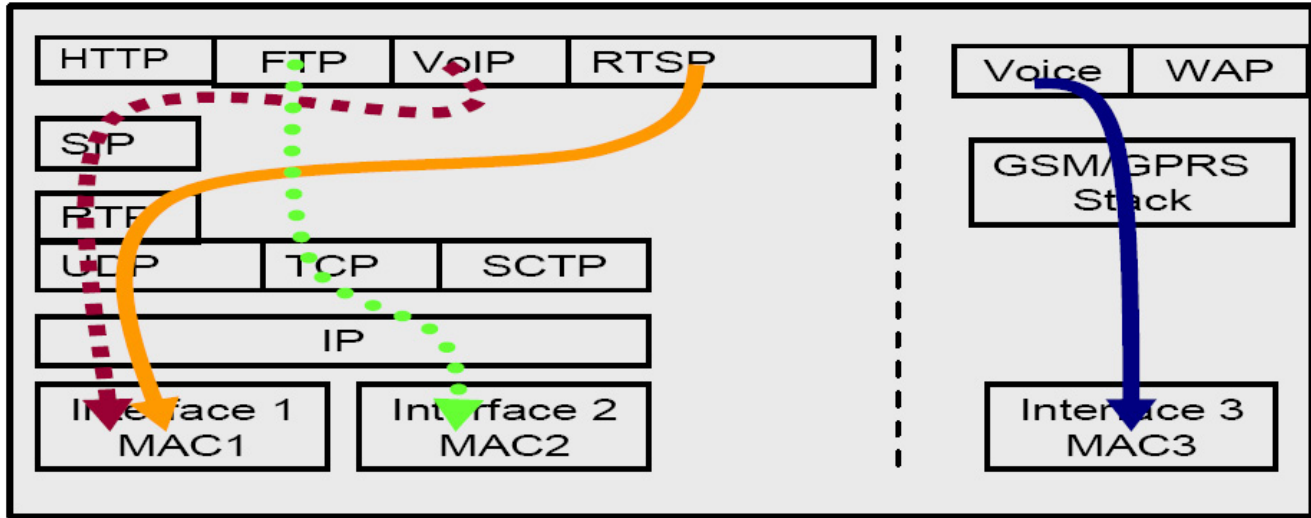

Figure 13. Different active Sessions on a Device

when the Triggering Device is not involved in the current session. In this case Triggering Device needs to discover different active sessions on the Source Device to select the one it desires to transfer.

According to the fact that each session on a terminal uses its proper protocols in each layer of the protocol stack (Fig. 13), all the sessions on a terminal should be described with a session digest in a manner that they can be distinguished from other sessions. Digest of a session is the minimum piece of information which unify a session.

SDP-Session Description Protocol [11] describes the sessions with identifying the following information: i) five tuple information: Source IP address, Destination IP address, Source port No., Destination Port No. and transport protocol name. ii) Session ID. iii) Connection Protocol (Internet, CS, etc.). iv) Media Type (Video, Audio, etc.). v) Format of the media (G711 voice, H261 Video, MPEG Video, etc). SDP is currently used in SIP-Session Initiation Protocol and RTSP [21]. RTSP is standardized for streaming services and is used more and more in such kinds of applications.

After device discovery, when the Target Device was chosen, the Corresponding Device will be informed about the new device parameters and if required, the session re-negotiation for new parameters will be accomplished. Then finally, the media will be established between Target Device and Corresponding Device. In some cases, after a while, the Source Device needs to retrieve the session. We call that session resume or session retrieval. For example, consider that a user transfers a voice session from his cell phone to his laptop when he arrives in the coverage of the WLAN at his home. Then after some minutes he decides to leave his home, so he should be capable of retrieving his session on his cell phone.

In session mobility, there are also some advanced interesting features: session splitting and merging. Session splitting means that a composed session is split over several simple sessions on different devices. For instance, a video phone including video and voice, may be split over three sessions as follow: Ingress Video, Egress Video and Voice. In contrast, session merging is required to merge a sessions that is split over several devices to a single session on a unique device.

Session Mobility solutions are proposed in different layers: In network layer, MIPv6 with some modification will be able to

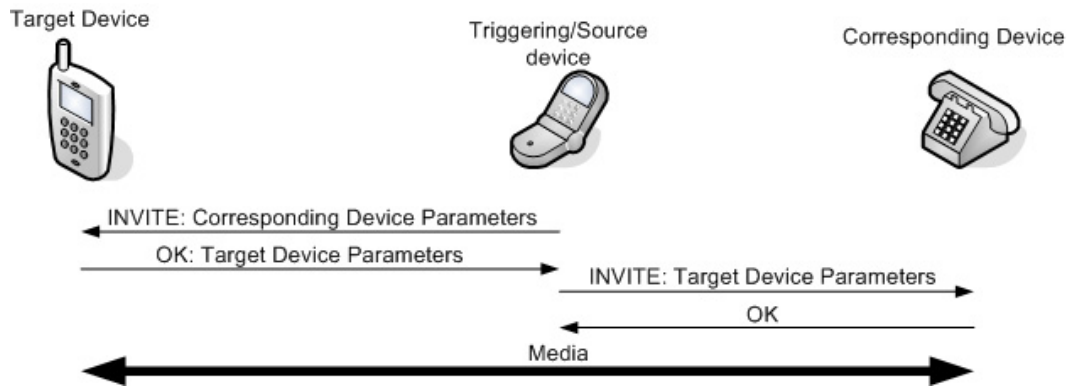

Figure 14. SIP based Third Party Control approach for Session Mobility

support session mobility [13]. MIP makes a MN- Mobile Node- accessible when it changes its IP address by providing a binding between Care of Address (New Address) and Home Address of MN. If MIP creates a binding between two Home IP Addresses of two different devices, it will be able to provide session mobility. The main limitation of MIP solution for session mobility is that all the active sessions of a device will be transferred together. There are also some solutions for session mobility in transport layer such as TCP-Migrate [23] that supports session mobility for a certain transport protocol (TCP). However, we focus on the solutions based on SIP for two main reasons: Firstly, IMS is based on SIP. Secondly, session mobility solutions based on SIP in comparison to the other approaches are much more flexible in supporting advanced features like session splitting and merging.

4.2 SIP based session mobility approaches

Two approaches for SIP based session mobility exists: *Third Party control* and *REFER method*. To simplify the scenarios of our examples, we ignore the Device Discovery Phase and we assume that the Target Device is already selected. In addition, we consider that Triggering and Source Device are the same.

- **Third Party Control** [22]: The Signalling Flow of this method is depicted in Fig. 14. In this figure, D1 is the Triggering/Source device and D2 is considered as Target Device. In addition the Corresponding Device is indicated by CD. To trigger the session mobility, D1 sends an INVITE request to D2 conveying the SDP parameters of the Corresponding Device. Then D2 responds with an OK and indicates its preferred SDP parameters to D1. Then D1 use these parameters and sends an INVITE to CD including the SDP parameters of D2. If CD agrees with these parameters, it sends an OK to D1, and then the media will be transferred to the D2. In this method there is no direct session negotiation between CD and D2. In fact, all the SIP messages will be passed through D1; this is why this method is called third party controlled. However, the media may be end-to-end or again being proxied by D1.

This method supports easily session splitting [22]. But there are some essential limitations: Firstly, the session transfer will be triggered always by Triggering Device. Secondly, even after transfer, the Triggering Device should remain active for session re-negotiation during the session; therefore, if for example Triggering Device gets a battery failure, or leaves the area, the session will be lost.

- **REFER METHOD** [22]: REFER method is defined by IETF Sipping group in a separate RFC [24] as an extension to the SIP methods defined in RFC 3261. Figure 15 describes the session mobility signalling flow by using REFER

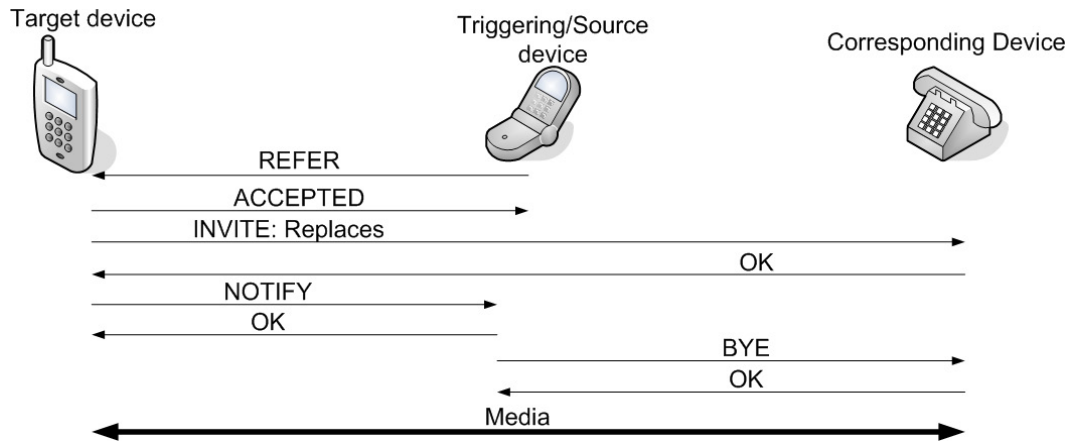

Figure 15. Session Mobility by employing SIP REFER Method

method. D1 sends REFER to the D2 asking to accept its active session. If D2 accepts, it will send an ACCEPTED to D2. And then it creates an INVITE targeting to CD. This INVITE contains a Replace header, explaining the modification of the session parameters. CD informs D2 its acceptance with an OK. Then D2 sends a NOTIFY to D1 to inform it about the success of the negotiations. Then, in the last phase, D1 sends a BYE to CD and quits the session. In this time, the media will be transferred to D2. This method, cope with the main draw back of the third party control mode. It means that, the Triggering Device will be no more in the session signalling. However, with this method the session splitting is more complicated to be implemented [22]. In fact, if Triggering Device desires to split its session over D1 and D2, it should send two separate REFER to each device; in consequent, each of these two devices will contact CD separately by sending an INVITE. There is no guaranty that these two INVITES arrive in the same time, hence there will be the problem of session synchronization.

According to the fact that IMS uses SIP, the SIP based session mobility is easy to be adopted in IMS. However the implementation of these SIP based approaches is not that straightforward and there are two important issues as follows.

- Third party controlled method is not accepted in IMS because of security problem. In fact, it is not acceptable that a transferred session will be controlled by a terminal (triggering device) which is not involved anymore in the session.
- using REFER method for session mobility as what is proposed by IETF, push a huge amount of signalling load in the radio links.

Figure 16 shows that in REFER method (without modification) a session transfer requires the exchange of 18 signalling messages which all pass through the access networks. These issues are our main motivation to develop a Mobility Server which connects to IMS via ISC interface similar to other application services. The mobility server handles the mobility features that the mobility management mechanism of the network (like mobile IP) can not manage. These features include: session mobility, session splitting/merging, personal mobility, service mobility and service adaptation to the user context.

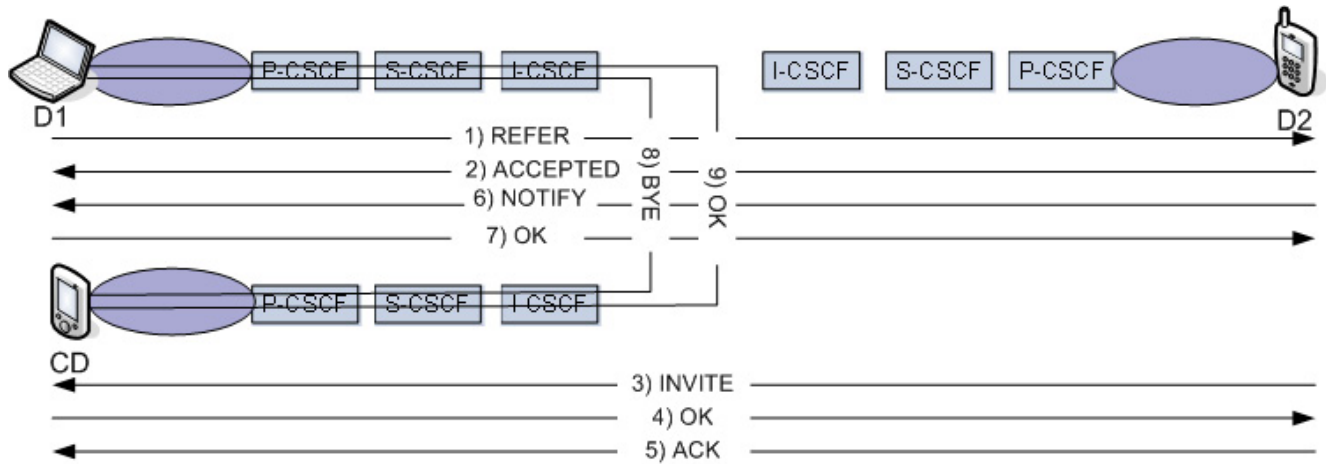

Figure 16. REFER Method Session Mobility without Mobility Server in IMS

Fig. 17 shows the overall architecture and the situation of the Mobility Server. Numerous advantages may be achieved by deploying such mobility server. As a matter of fact, because it is deployed as a service and is connected to IMS via the same interface as other application servers, it is able to cooperate with other services to provide enhanced features in mobility management. This cooperation can be provided by SCIM (Service Capability Interaction Manager). The SCIM is a special kind of SIP application server which performs feature interaction management, and connects to application servers using the same ISC interface. For instance, the collaboration of Location Server and this server can bring in location aware handover. The location information provided by GPS and analyzed by the location server can be sent to this mobility server. Then according to the location, movement direction of the user and the session QoS parameters, the best access technology in that proximity will be chosen in handover process.

The focus of this paper is only on the Session Mobility feature that this Server can provide by using the service convergence that IMS brings for heterogeneous access technologies.

4.3 Session Mobility Managed in Application Level

As we mentioned before, the two SIP based session mobility approaches proposed by IETF can not be used directly in IMS. By deploying Mobility server, we propose a combination of these two approaches to benefit the strong points of each approach as well as cope with the drawbacks of them. Figure 18, shows the session mobility signalling flow with the

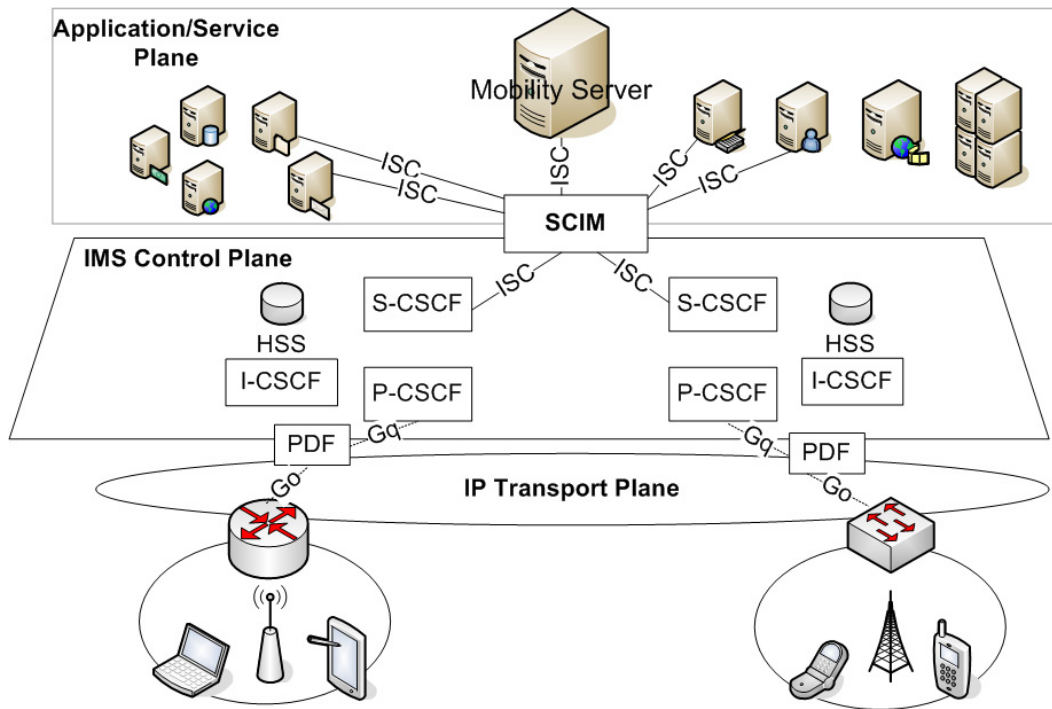

Figure 17. Position of Mobility Server in IMS Architecture

existence of a Mobility Server in IMS. Mobility server receives the REFER method from Triggering Device. Then it starts an approach like third party control method. By using this hybrid method, the number of SIP messages which pass through access network will be decreased to half. In addition there is no more the problem of third party control method that even after session transfer, the session should be controlled by the previous device. In our method, Mobility server receives the REFER from D1 requesting transfer of the session to D2. Then Mobility Server, sends an INVITE with CD parameters to the D2. If D2 accepts, it will send an OK with its parameters. Then Mobility Server provides another INVITE destined to CD conveying D2 parameters. After acceptance of CD, Mobility Server sends BYE to D1 and the session will be established

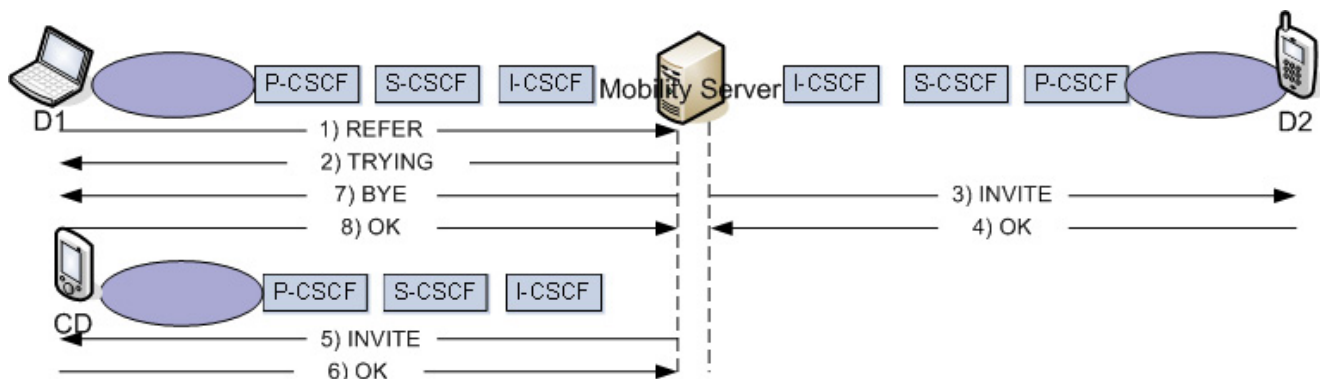

Figure 18. Session Mobility by using Mobility Server in IMS

between D1 and CD.

Advanced features can be considered in this architecture for session mobility:

Device Discovery: Each domain can deploy local device/service discovery mechanism. Device discovery enhance the session mobility features. With contact to Service Discovery Directory Agent, IMS clients will be able to discover the devices with different capabilities in that proximity. Each subscriber, according to its profile is authorized to use a certain number of devices.

Combination of Device Discovery and Session Mobility Process: The process of device discovery and session mobility may be combined. In this approach, instead of indicating the exact contact information of the new device, the Originating Device, just sends the Mobility Server a description of the capabilities of the Target Device that the user desires. Then the Mobility Server sends a query to the Service Discovery Directory Agent (DA). DA replies back to this request with a list of available devices compatible to the request. The Signalling flow is depicted in Figure 19.

Session Splitting: Figure 20 shows our session splitting approach. Triggering Device sends REFER to Mobility Server. In this REFER, the Triggering Device, indicates the desired Target Devices for each session component. Mobility Server, according to the received REFER, creates separate INVITEs with the relevant SDP parameters for each of the Target devices. Then each of the target devices receives only the SDP parameters of a part of the original combinational session. Each target device replies with an OK indicating its desired parameters for their relevant session. Then, Triggering Device concatenates all the SDP parameters of each target device in a single INVITE and sends it to the Corresponding Device.

4.4 Session Mobility Server Advantages

The advantage of a mobility server similar to what we have proposed is that it can be connected to the policy decision function (PDF) and defines the session mobility strategies with considering the policy and available resources of each 3G and 802.11 access technologies. By defining advanced strategies, this mobility server enables: 1) Selecting the best access compatible to user constraints (ie cost constraints) and required resources for the active services. 2) Load balancing among different network technologies. 3) Having the capability of splitting different ongoing sessions belonging to one user over different accesses (if user is accessible simultaneously via different connections). The advanced policies for session mobility can be defined based on:

1. **Better QoS:** The user may trigger the session mobility process to receive better QoS via other access technology.
2. **Service Request:** If the requested service can not be supported in the current access technology(due to policy rules etc.), the user may trigger the session transfer.
3. **Availability of better price:** The active session of a user may cost cheaper via another access technology. In this case, the user may transfer its session to achieve better price.

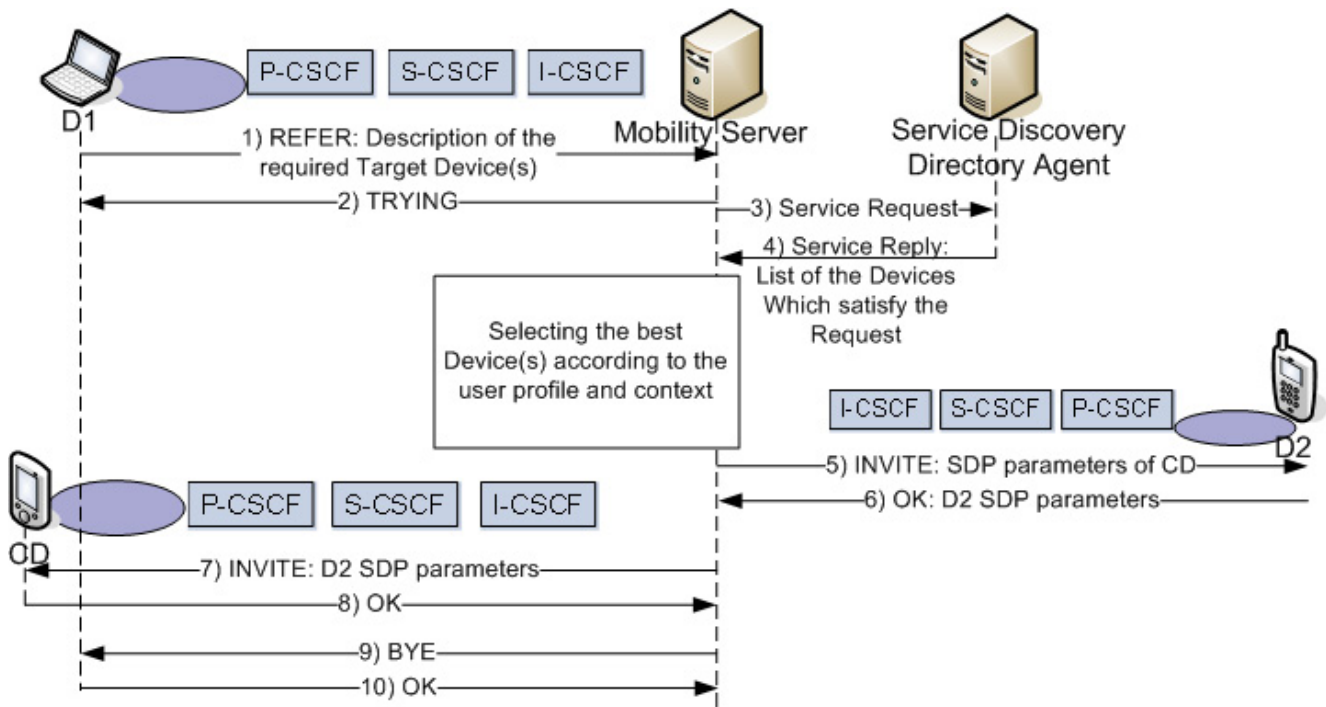

Figure 19. Combination of Device Discovery and Session Mobility Signalling

4. **Load Balancing:** The network operator may transfer some active sessions from one access technology to another to achieve a better resource utilization. This decision should be based on the available resources in each access technology

4.4.1 Mobility Server and Load Balancing

In the overlapping area, two tiers of access technologies with hybrid characteristics and different QoS provisioning system are available. Then, it comes the problem of optimized distribution of multi-class traffics over the hybrid shared resources of these two access technologies in order to reach the best resource utilization and user satisfaction. Admission policies for the new user service requests in the overlapping area influence the load balancing over the hybrid system. However, in addition to the new requests there are also active sessions which may arrive in the overlapping areas. For instance consider a user with a video-phony session via 3G system who arrives in the WLAN/3G overlapping area. The transfer of such sessions from one access technology to another based on the availability of the resources can improve significantly the load balancing in the system. Mobility Server is able to provide such a feature because it has access to the PDF and is aware of the available resources in each technology.

For load balancing our goal is to select an access technology for a client according to its active sessions in a manner that the set of overlapping accesses can admit the most number of clients of each service. Access networks should be classified for different applications regarding to their performance and capabilities. For example, one efficient strategy may be allocating

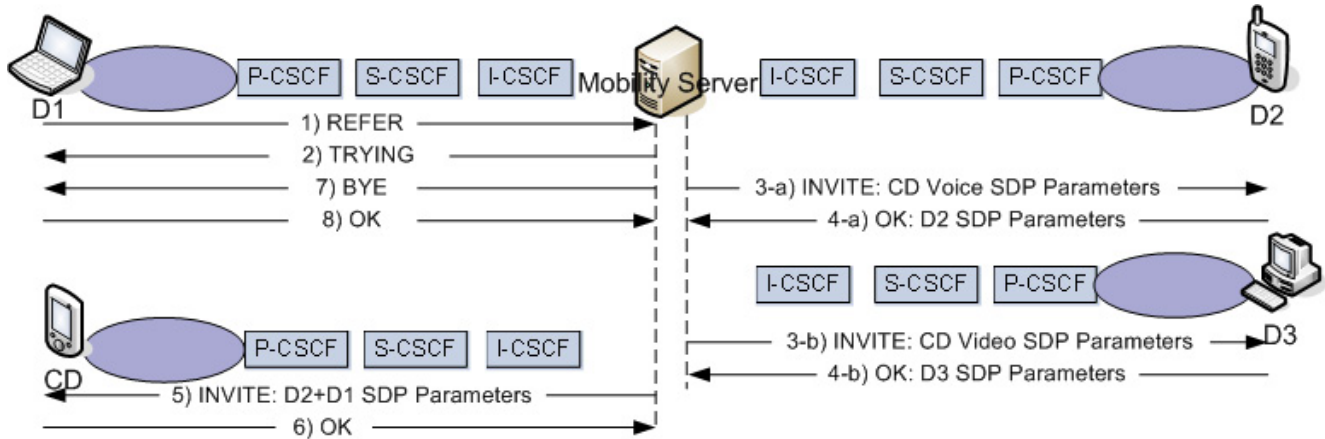

Figure 20. Session Splitting with Mobility Server in IMS

access technologies with limited bandwidth but dedicated resources to the voice; and on the other hand considering accesses with higher bandwidth and common resources to the bandwidth consuming applications.

The resources in 3G domain is organized and deterministic. 3G guaranties a certain amount of resources for each service class. On the other hand, 802.11 WLAN proposes a random access media with shared resources. Therefore in 802.11 the allowed number of each service class in the system can be very flexible.

In order to specify the limit for the number of each service class, a performance metric should be defined in WLAN. In 802.11 WLAN, collision is the major phenomena that affects the performance of the system. To control the collision rate in a WLAN, admission of users should be limited. On the other hand, the admission rules should not be so strict that resources remain unused and idle. Taking these two issues in the note, we consider $1 - (P[idle] + P[collision])$ as the performance metric in WLAN.

Figure 21 illustrates the general pattern of $1 - (P[idle] + P[collision])$ in WLAN based on the number of two service classes (voice and data) in the system. $P[idle]$ is the probability that a transmission time slot in 802.11 medium access remains idle; and $P[collision]$ is the probability of collision in a transmission time slot. With the increase (decrease) in the total number of admitted stations the $P[idle]$ merges to zero (one) however the $P[collision]$ limits to one (zero). Therefore $P[idle] + P[collision]$ is always greater than a certain minimum level. Considering two kinds of services *voice* and *data*, with (n_v/n_d) as the number of the voice/data users, this minimum level is obtained when $(n_v, n_d) = ((n_{v,opt}, n_{d,opt})$. The minimum level indicates the most efficient resource utilization in WLAN where the resources are neither remained idle nor the network is overcharged with high collision rate.

However, this optimum point in WLAN does not necessarily optimize the performance of the whole hybrid system. Therefore, some conditions such as $\Gamma_{d,Limit}$ as the throughput limit (bits/sec) of data services in the whole overlay system and B_{limit} for the limit of blocking rate of voice services are also enforced. Consequently, an optimization problem is defined as

the following:

$$(n_v, n_d) | (P[idle] + P[collision]) = \text{minimum} \quad (1)$$

Subject to

$$\begin{aligned} \rho_v &< 1 \\ \Gamma_d &\geq \Gamma_{d,limit} \\ \text{Call - Block} &\geq CB_{Limit} \end{aligned} \quad (2)$$

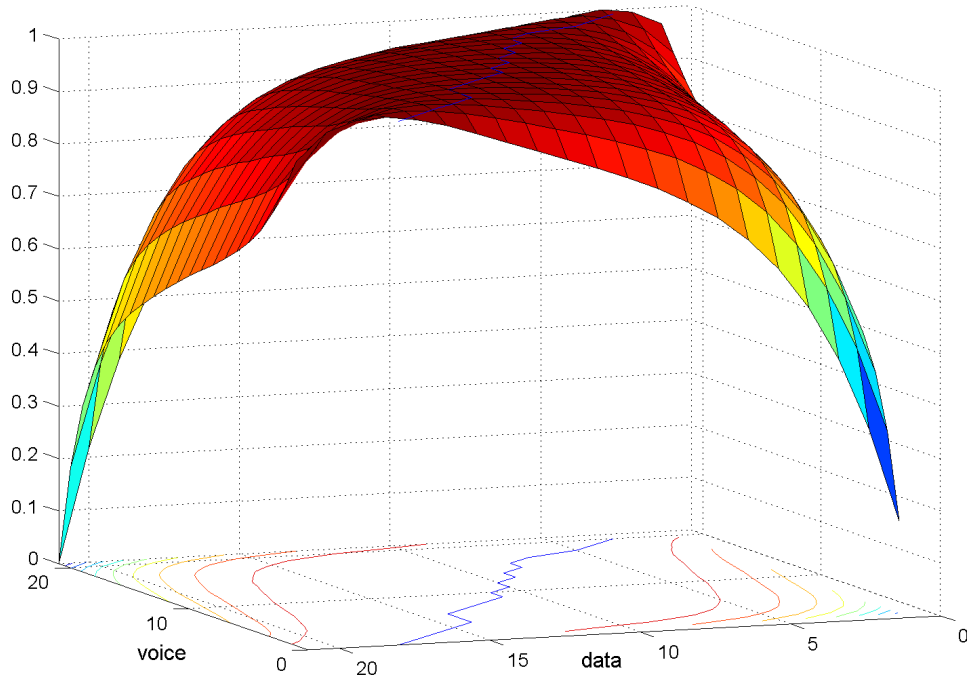

Figure 21. 1-(P[collision]+p[idle])

ρ_v is the saturation factor for voice traffic in the access point (AP). As explained in section 3.3.2, when there are n_v voice sessions with bit rate of λ in a WLAN, the AP's traffic rate will be $n_v \times \lambda$. Now, if we consider that AP manages to access the

Table 2. Parameter Values of 802.11b and 802.11g

	802.11b	802.11g
DIFS	50 μ s	28 μ s
SIFS	10 μ s	10 μ s
Slot Time	20 μ s	9 μ s
CWmin	32	16
CWmax	1024	1024
Retry Limit	7	7
Supported Data Rates	1, 2, 5.5 and 11Mbps	6, 9, 12, 18, 24, 36, 48 and 54Mbps
ACK frame	10.2 μ s	2.1 μ s
PLCP and Preamble	192 μ s	24 μ s
MAC Header + FCS	24.7 μ s	5 μ s

channel with the rate μ to transmit its traffic, $\rho_v = \frac{n_v \times \lambda}{\mu}$ indicates the the voice traffic queue size in the AP and represents the saturation status of the AP.

Γ_d is the throughput (bits/sec) of data services in the whole overlay system. This throughput should be guaranteed to remain higher a defined limit in the whole system. With considering $\Gamma_d \geq \Gamma_{d,limit}$, the decision for a session transfer/admission in the WLAN will be taken based on the whole Cellular/WLAN system data throughput.

Based on this admission strategy, in our system the mobility server decides to transfer a session from one access technology to the other one. Moreover, we also consider session splitting as another feature of the mobility server to improve the load balancing. With session splitting, the elements of a complex session can be distributed over 802.11 and 3G interfaces based on their required resources. For instance for a Video-phony, the data and video part can be sent/received from 802.11 and the voice can be kept on 3G interface. This can help the better utilization of resources. In the next section we show the effects of session mobility/splitting on the resource utilization efficiency.

4.5 Simulation Model and Results

Our simulation is carried out in a two overlapping 3G/WLAN test bed by using NS2.28. WLAN is simulated based on IEEE 802.11b MAC technology with 11Mbps bandwidth and the parameters indicated in the table 2. Moreover, the bandwidth of 3G technology is considered to be 2Mbps. Two kinds of traffic classes are considered for voice and data. The data traffics are considered to have the maximum bitrate of 100KBps and packet size of 500 byte. For the voice traffics we consider the iSAC codec with bitrate of 10Kbps in WLAN. However in the 3G we consider the bitrate of 32Kbps for each voice session.

In the 3G 1Mb of the bandwidth is shared for all the data traffics. However the rest 1 Mb is divided by 32kbps and creates 32 places for voice sessions. Moreover, if the data resources are not completely used, voice sessions can also occupy the available resources in this part. According to the organized resource sharing system in the 3G, the available resources is calculated simply based on the number of admitted sessions of each traffic class. However, for WLAN it is the saturation

factor of AP (ρ) which specifies the available resources.

The new sessions are admitted in the system one by one. With the probability of 0.5, each new session is either voice or data. In each simulation round the new sessions are admitted to the system until the sum of the requested resources are equal to the maximum capacity of the system. In each simulation round, we limit the maximum number of the requests which are in the overlapping area (in the coverage of WLAN). For instance in a simulation round we consider that only 10 percent of the users are in this overlapping area. Then, we vary this percentage from 5 to 35% and repeat the simulation in a separate round for each value. Subsequently, we calculate the resource utilization factor (RUF) in each round. RUF is equal to the allocated resources over the requested resources.

In the figure 22, Resource Utilization Factor (RUF) is demonstrated versus network requested load and the overlapping area population limit. Moreover, we have calculated the call blocking ratio in the system for the case that the overlapping population limit is equal to 25%. Figure 23 shows the results for the voice call blocking ratio. We have carried out the

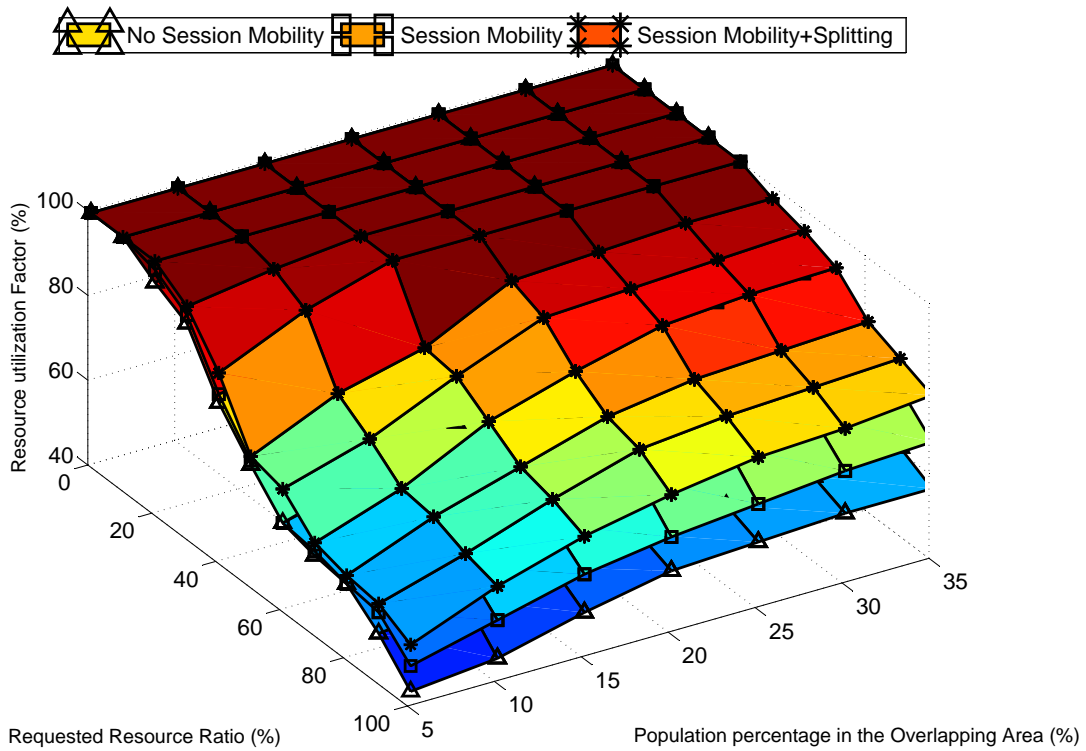

Figure 22. Resource Utilization Factor

simulation for three different cases as follows. 1) We just consider the admission policies we have defined in the equation 1 with no session mobility. 2) We add the session mobility feature to improve the load balancing by transferring the sessions from one technology to the other according to their characteristics and available resources. 3) Finally we add the session

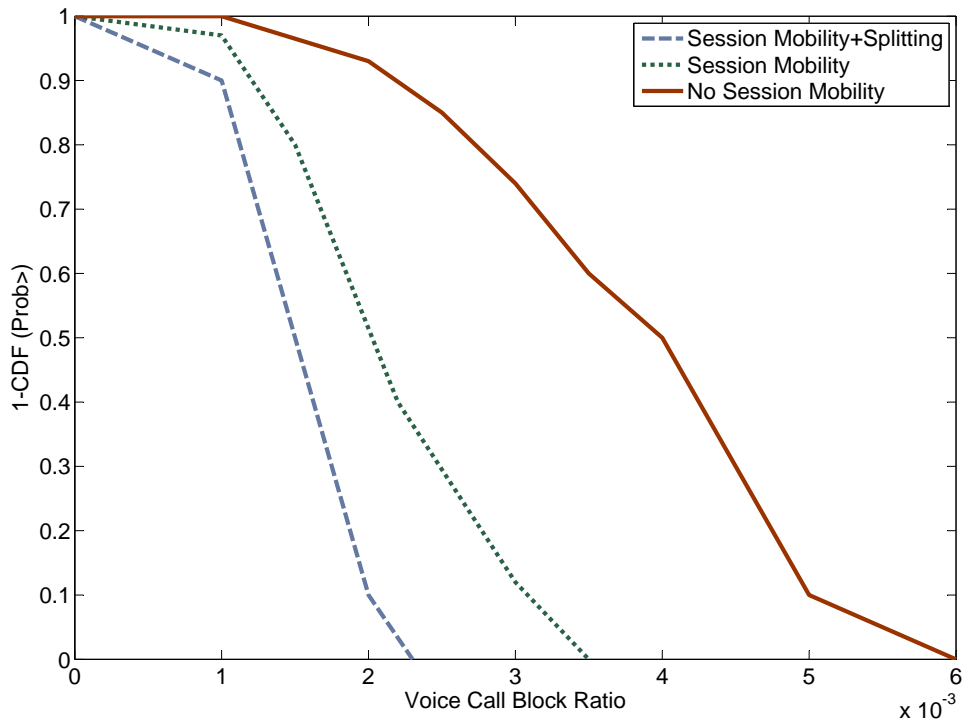

Figure 23. Voice Call Block

splitting feature to evaluate how it can improve the load balancing.

As displayed in Figure 22 when considering session mobility+splitting, the RUF remains always upper than 75%. In addition if the WLAN hot-spot is located in the crowded area in a manner that more than 35% of the users be in the overlapping area, even with high resource request, the RUF remains more than 85%. It means that the resources are allocated efficiently. However for the case that only admission control distribute the load for new arriving requests, RUF can fall down to 40% in high resource request situations. Moreover, the voice call blocking ratio remains only less than .002 with session mobility+splitting.

5 Related Work

To reach a scalable and reliable architecture for horizontal Fixed/Mobile Convergence, CableLabs has decided to adopt IMS as the service control overlay in the PacketCable 2.0 project [7]. In this frame, CableLabs is collaborating with 3GPP in order to modify and reproduce some IMS aspects in order to extend IMS services to broadband Cable technologies. In [17] a step by step strategy to move toward Cable technology with IMS is defined. Moreover all of the important challenges including SIP protocol compatibility, resource reservation, unified authentication system is discussed in this paper. In [14] the

details of the required architecture and signaling flow for a non-SIP based device access to PacketCable IMS are introduced.

The work on getting IMS integrated in broadband fixed technologies is also being pursued by a standardization body in ETSI (European Telecommunications Standards Institute), called Telecommunications and Internet converged Services and Protocols for Advanced Networking (TISPAN) [10] group in ETSI. TISPAN is considering some part of the work on IMS done by 3GPP as their Service Layer Model [9]. The TISPAN specifications are supposed to stretch IMS services to broadband xDSL subscribers. The specified architecture is structured according to a service layer and an IP-based transport layer. The service layer includes four major subsystems as follows.

- The core IP Multimedia Subsystem (IMS);
- The PSTN/ISDN Emulation Subsystem (PES);
- Other multimedia subsystems (e.g. IPTV Dedicated Subsystem) and applications;
- Common components (i.e. used by several subsystems) such as those required for accessing applications, charging functions, user profile management, security management, routing data bases (e.g. ENUM), etc.

The "Core IMS" is a subset of the 3GPP IMS which is restricted to the session control functionalities. Application Servers (AS) and transport/media related functions such as the Multimedia Resource Function Processors (MRFP) and the IMS Media Gateway function (IMS-MGW) are considered to be outside the "Core IMS". The transport layer provides IP-connectivity to user equipment under the control of the network attachment subsystem (NASS) and the resource and admission control subsystem (RACS). These subsystems hide the transport technology used in access and core networks below the IP layer. NASS provides the required functionalities for IP address provisioning, IP layer authentication, authorization of network access according to user profile etc. RACS is the TISPAN NGN subsystem responsible for the implementation of procedures and mechanisms handling policy-based resource reservation and admission control for both uni-cast and multi-cast traffic in access networks and core networks. TISPAN architecture is proposed for broadband access technologies like xDSL.

Moreover, in [1], 3GPP has proposed an architecture to allow WLAN access to 3G services. This is a general architecture to provide access to all services in 3G domain including IMS services. With the proposed architecture the roaming of 3G clients in WLAN domain is feasible. This is a Master/Slave architecture where 3G controls the access to services and defines the corresponding policies.

Finally, we should mention that there are also some researches for IMS integration in Wimax. In [4] different levels of service integration between 3G and Wimax based on IMS is analyzed. Figure ?? depicts the architecture of blended access technologies with IMS overlay.

6 conclusion

In this paper different strategies for adopting IMS in WiFi technology was proposed. IMS as the most complete service control overlay can bring in horizontal convergence of different access technologies which consequently leads to advance services (such as inter-technology session mobility). We presented the challenges and limitations of the proposed approach by the 3GPP for 3G-WLAN interconnection. Then to cope with these limitations, we proposed three phase-by-phase strategies of IMS deployment in WiFi domains. The defined strategies allow the WiFi operators to inter-connect their networks to 3G domain in a win-win condition. The defined strategies get over the existing problems in 3GPP approach such as Master/Slave inter-working architecture, complicated session set up process and requirement of multi stack support in end user device.

Moreover, we focused on the extension of IMS based QoS control system to be applicable to a multi-access and hybrid technology domain. In this regard, we proposed two different solutions that allow all the access technologies to express their resource allocation policies in a multi-access IMS domain. Subsequently, we took the advantage of IMS architecture and introduced a Mobility Server over hybrid 802.11/3G. The Mobility Server provides Session Mobility between the devices in different access technologies. SIP based session mobility approaches are modified to reduce the required signalling for session transfer. One of the distinguished advantages of this Mobility Server is that it is defined at service level and is accessible via the same interface as other application services. Therefore with collaboration of Mobility servers and other servers like Directory Agent Service Discovery, new advanced features like combined Device Discovery and Session Mobility can be provided. We have also shown that how session mobility can lead to better utilization of resources in a hybrid 802.11/3G domain. According to our simulation results, defining the efficient policies and transfer of the sessions from one technology to another based on their QoS requirements lead to improvement in resource utilization up to 30%.

References

- [1] 3GPP. 3GPP System to Wireless Local Area Network (WLAN) interworking; System Description. *TS 23.234, Release 7, v7.6.0*, 2007.
- [2] 3GPP. End-to-End QoS Signalling Flows. *TS 29.208, Release 6, v6.7.0*, 2007.
- [3] 3GPP. IP Multimedia Subsystem (IMS). *TS 23.228, Release 8, v8.2.0*, 2007.
- [4] A. T. A. Hasswa and H. Hassanein. Interworking of Wimax and 3GPP networks based on IMS (IP Multimedia Systems) Infrastructure and Services. *Proceeding of IEEE LCN, Dublin, IRELAND*, pages 931 – 938, October 2007.
- [5] O. Andrisano, A. Bazzi, M. Diolaiti, C. Gambetti, and G. Pasolini. UMTS and WLAN integration: architectural solution and performance. *Proceedings of IEEE PIMRC*, pages 1769 – 1775, September 2005.
- [6] W. Bhm and P. Braun. Policy Base Architecture for the UMTS Multimedia Domain. *Proceeding of IEEE NCA*, pages 275 – 285, April 2003.
- [7] CableLab. *PacketCable 2.0*. <http://www.packetcable.com/specifications/specifications20.html>.

- [8] W. Z. et al. Policy-Based QoS Architecture in the IP Multimedia Subsystem of UMTS. *IEEE Network*, pages 51– 57, May/June 2003.
- [9] ETSI. TISPAN IP Multimedia Subsystem core component. *ES 282 007, Version 1.2.6*.
- [10] ETSI. TISPAN NGN Functional Architecture. *ES 282 001*.
- [11] M. Handley, V. Jacobson, and C. Perkins. SDP: Session Description Protocol. *IETF RFC 4566*, 2006.
- [12] C. Low. Integrating Communication Services. *IEEE Communication Magazine*, page 164 169, June 1997.
- [13] W. Lu, A. Lo, and I. Niemegeers. Session Mobility Support for Personal Networks Using Mobile IPv6 and VNAT. *Proceeding of the ASWN Workshop, Paris, FRANCE*, June 2005.
- [14] M. Mani and N. Crespi. Access to IP Multimedia Subsystem of UMTS via PacketCable Networks. *Proceeding of IEEE WCNC, New Orleans, LA, USA*, pages 2459–2465, March 2005.
- [15] M. Mani and N. Crespi. New QoS Control Mechanism Based on Extension to SIP for Access to UMTS Core Network via Different Kinds of Access Networks. *Proceeding of IEEE WiMob, volume 2, Montreal*, pages 150–157, August 2005.
- [16] M. Mani and N. Crespi. Inter-Domain QoS Control Mechanism in IMS based Horizontal Converged Networks. *Proceeding of IEEE ICNS, Athens, Greece*, 2007.
- [17] M. Mani and N. Crespi. How IMS Can Enable Converged Services for Cable and 3G Technologies: a Survey. *accepted in EURASIP Journal on Wireless Communication and Networking*, 2008.
- [18] J. Rosenberg. Interactive Connectivity Establishment (ICE): A Methodology for Network Address Translator (NAT) Traversal for Offer/Answer Protocols, October 2007. Internet Draft draft-ietfmmusic-ice-19, Internet Engineering Task Force, work in progress.
- [19] J. Rosenberg, J. Weinberger, C. Huitema, and R. Mahy. STUN - simple traversal of user datagram protocol (UDP) through network address translators (nats). *IETF RFC 3489*.
- [20] S. Salsano and L. Veltri. QoS Control by Means of COPS to Support SIP-Based Applications. *IEEE Network*, pages 27–33, March 2002.
- [21] H. Schulzrinne, A. Rao, and R. Lanphier. Real Time Streaming Protocol. *IETF RFC 2326*, 1998.
- [22] R. Shacham, H. Schulzrinne, S. Thakolsri, and W. Kellerer. Session Initiation Protocol (SIP) Session Mobility, November 2007. Internet Draft draft-shacham-sipping-session-mobility-05, Internet Engineering Task Force, work in progress.
- [23] A. C. Snoeren. *A session-based approach to Internet mobility*. PhD thesis, Department of Electrical Engineering and Computer Science, MIT, 2002.
- [24] R. Sparks. The Session Initiation Protocol REFER Method. *IETF RFC 3515*, 2003.
- [25] V. Varma, S. Ramesh, K. Wong, M. Barton, G. Hayward, and J. Friedhoffer. Mobility management in integrated UMTS/WLAN networks. *Proceedings of IEEE ICC*, pages 1048 – 1053, May 2003.
- [26] A. Westerinen, J. Schnizlein, J. Strassner, M. Scherling, B. Quinn, S. Herzog, A. Huynh, M. Carlson, J. Perry, and S. Waldbusser. Terminology for Policy Based Management. *IETF RFC 3198*, 2001.
- [27] R. Yavatkar, D. Pendarakis, and R. Guerin. A Framework for Policy-based Admission Control. *IETF RFC 2753*, 2000.