



**HAL**  
open science

# Nonparametric probabilistic approach of uncertainties for elliptic boundary value problem

Christian Soize

► **To cite this version:**

Christian Soize. Nonparametric probabilistic approach of uncertainties for elliptic boundary value problem. International Journal for Numerical Methods in Engineering, 2009, 80 (6-7), pp.673-688. 10.1002/nme.2563 . hal-00684335

**HAL Id: hal-00684335**

**<https://hal.science/hal-00684335>**

Submitted on 1 Apr 2012

**HAL** is a multi-disciplinary open access archive for the deposit and dissemination of scientific research documents, whether they are published or not. The documents may come from teaching and research institutions in France or abroad, or from public or private research centers.

L'archive ouverte pluridisciplinaire **HAL**, est destinée au dépôt et à la diffusion de documents scientifiques de niveau recherche, publiés ou non, émanant des établissements d'enseignement et de recherche français ou étrangers, des laboratoires publics ou privés.

# Nonparametric probabilistic approach of uncertainties for elliptic boundary value problem

Christian Soize<sup>1</sup>

<sup>1</sup>*Université Paris-Est, Laboratoire de Modelisation et Simulation Multiechelle, FRE 3160 CNRS,  
5 bd Descartes, 77454 Marne-la-Vallee, France*

## SUMMARY

The paper is devoted to elliptic boundary value problems with uncertainties. Such a problem has already been analyzed in the context of the parametric probabilistic approach of system parameters uncertainties or for random media. Model uncertainties are induced by the mathematical-physical process which allows the boundary value problem to be constructed from the design system. If experiments are not available, the Bayesian approach cannot be used to take into account model uncertainties. Recently, a nonparametric probabilistic approach of both the model uncertainties and system parameters uncertainties have been proposed by the author to analyze uncertain linear and nonlinear dynamical systems. Nevertheless, the use of this concept which has to be developed for dynamical systems cannot directly be applied for elliptic boundary value problem, for instance for a linear elastostatic problem relative to an elastic bounded domain. We then propose an extension of the nonparametric probabilistic approach in order to take into account model uncertainties for strictly elliptic boundary value problems. The theory and its validation are presented. Copyright © 2007 John Wiley & Sons, Ltd.

KEY WORDS: Uncertainties; Elliptic problem, Random matrices; Computational model

## 1. Introduction

Today it is well understood that uncertainties have to be taken into account in computational sciences in order to improve the predictions of the computational models or to perform robust design optimizations of complex systems. As soon as the probability theory can be used to model the uncertainties, such a theory must be used because it is one of the most powerful mathematical theory, without failure, allowing (1) finite and infinite dimensions problems to be modeled, (2) finite approximations of stochastic boundary value problems and convergence of the random solutions to be clearly constructed and analyzed, (3) the construction and the experimental identification of the probability models to be carried out using information theory and mathematical statistics.

---

\*Correspondence to: Christian Soize, Université Paris-Est, Laboratoire de Modelisation et Simulation Multiechelle, FRE 3160 CNRS, 5 bd Descartes, 77454 Marne-la-Vallee, France

In general, a computational model is derived from a boundary value problem for which the finite approximation is performed using appropriate methods such as the finite element method. Such a computational model depends on parameters (data) relative to the geometry of the domain, to the boundary conditions, to the coefficients of the partial differential equations corresponding to the description of physical properties of the media. Such uncertain parameters can also be defined as "system parameters uncertainties" in the computational model. When probability theory is used to model system parameters uncertainties, such an approach is referenced as the "parametric probabilistic approach of system parameters uncertainties" [?]. Such a parametric probabilistic approach of system parameters uncertainties has extensively been developed in the last two decades and is still in development. The objective of this paper is not to give a review of all the works produced in this area and we refer the reader to the literature (see for instance [?] for uncertainty in structural dynamics, [?] for a recent overview on computational methods in stochastic mechanics and in reliability analysis). In particular, the use of the Gaussian Chaos representation for stochastic processes and random fields [?] has been used to introduce useful and very efficient tools for analyzing stochastic systems using stochastic finite elements (see [?, ?]) and to develop many extensions and applications (see for instance [?] to [?]). Concerning the use of the parametric probabilistic approach of system parameters uncertainties for elliptic boundary value problems, we refer the reader (1) to [?] for aspects relative to the construction of approximations and convergence analysis concerning an elliptic problem for which a relatively simple stochastic model is used to model uncertainties and corresponds to a uniform elliptic condition and (2) to [?] for a complete construction of a stochastic model of uncertainties corresponding to a non uniform elliptic condition.

The model uncertainties are induced by the mathematical-physical process used to construct the boundary value problem and thus to construct the computational model. The model uncertainties must carefully be distinguished from the system parameters uncertainties in a computational model. If the parametric probabilistic approach is the most powerful method to take into account system parameters uncertainties, such an approach cannot address the model uncertainties as it is proved in [?, ?, ?]. In this context, a nonparametric probabilistic approach of model uncertainties has been proposed [?] as a possible way to circumvent these difficulties. This approach introduced a new concept with respect to the parametric approach in order to be able to take into account model uncertainties. The construction of the nonparametric probability model is based on the use of the information theory and the maximum entropy principle [?, ?, ?, ?, ?] in the context of the random matrix theory [?, ?].

The concepts for the nonparametric probabilistic approach of uncertainties has been introduced in [?]. Since this first paper, many works have been published in order to extend the theory and to validate it. The developments concerning the algebraic closure of the probabilistic model and its convergence as dimension goes to infinity can be found in [?] for the transient linear stochastic elastodynamics. This paper shows that the theory is consistent for the continuous systems in infinite dimension. The random eigenvalue problem and the non adaptation of the Gaussian Orthogonal Ensemble (GOE) for low-frequency dynamics has been analyzed in details in [?]. Recently, an extension of the theory has been proposed in [?] for the nonparametric stochastic modeling of the linear systems for which the variances of several eigenvalues are prescribed. Such an extension of the theory allows a more flexible description of the dispersion levels of each positive definite random matrix. The linear dynamical systems have also been studied in the medium-frequency range in taking into

account the model uncertainties and the system parameters uncertainties (see [?]). The theory has been extended to dynamical systems for which model uncertainties are not homogeneous through the system. The dynamic substructuring techniques have thus been introduced (see [?, ?, ?]). The model uncertainties in dynamical systems with cyclic symmetry have been studied in [?, ?]. The construction of a probabilistic model for impedance matrices can be found in [?, ?]. Recently, the nonparametric stochastic modeling has been used to propose a methodology to analyze structural dynamic systems with uncertain boundary conditions (see [?]). The capability of the nonparametric probabilistic approach to take into account both the model uncertainties and the system parameters uncertainties (while the parametric probabilistic approach can take into account only the system parameters uncertainties) has been analyzed for several simple and complex dynamic systems in [?, ?, ?]. Some new ensembles of random matrices for model uncertainties in coupled dynamical systems such as structural acoustic systems have been introduced in [?]. Significant efforts have been performed to develop experimental identifications of the nonparametric probabilistic approach and to obtain experimental validations of the theory in structural dynamics (see [?, ?, ?, ?, ?, ?]) and in structural acoustics (see [?, ?, ?, ?] and in particular, for the methodology and the experimental validation see [?, ?, ?]). Finally, the nonparametric probabilistic approach has been extended to analyze nonlinear elastodynamics with local nonlinear elements [?, ?] and with distributed nonlinear elements or nonlinear geometrical effects [?].

The concept of the nonparametric probabilistic approach introduced in [?] consists in directly constructing the probability distribution of each operator of the boundary value problem [?, ?, ?, ?] instead of deducing the probability distribution of each random operator from a deterministic transformation of random variables as used by the parametric probabilistic approach of system parameters uncertainties. The construction of the probability distribution of a random operator requires the introduction of a reduced model, that is to say the introduction of a sequence of random operators with finite ranks corresponding to the projections of this random operator on a sequence of finite subspaces of the space of admissible functions of the boundary value problem. This sequence of finite subspaces are constructed in choosing a basis of the admissible space of the boundary value problem. Using such a basis, the sequence of random operators with finite ranks corresponds to a sequence of random matrices. The probability distribution of each random matrix is then constructed using the Maximum Entropy Principle (Information theory) for which the constraints are defined by the available information. The convergence is analyzed for a dimension of the subspace going to infinity. For instance, in linear elastodynamics, the basis is made up of the elastic modes  $\{\psi^\alpha, \alpha \geq 1\}$  which are ordered by increasing eigenfrequencies and the stiffness random operator  $\mathbb{K}$  is projected on the finite dimension subspace spanned by  $\{\psi^1, \dots, \psi^N\}$  and is represented by a random matrix  $[\mathbf{K}_N]$ . For any fixed  $N$ , the available information for random matrix  $[\mathbf{K}_N]$  is the following: (1)  $[\mathbf{K}_N]$  is a random matrix with values in the set of all the positive-definite  $(N \times N)$  real matrices, (2) the mean value of  $[\mathbf{K}_N]$  is equal to the corresponding generalized stiffness matrix of the mean computational model and (3), the second-order moment of the random variable  $\|[\mathbf{K}_N]\}^{-1}\|$  is finite. For details concerning these developments, we refer the reader to [?, ?, ?, ?].

As explained above, the nonparametric probabilistic approach of both system parameters uncertainties and model uncertainties has mainly be developed and validated for linear and nonlinear dynamical systems. In this paper, we present a new extension of the nonparametric

probabilistic approach to analyze strictly elliptic boundary value problems with system parameters and model uncertainties. The mean computational model is assumed to be derived from the finite element discretization of a strictly elliptic boundary value problem and is then written as  $[\mathbb{K}]\underline{\mathbf{y}} = \mathbf{f}$ , in which the matrix  $[\mathbb{K}]$  is a sparse positive-definite  $(n \times n)$  real matrix,  $\underline{\mathbf{y}}$  is the unknown vector in  $\mathbb{R}^n$  and where  $\mathbf{f}$  is a given vector in  $\mathbb{R}^n$ . In practice, the mean computational model is used to construct the responses  $\underline{\mathbf{y}}^1, \dots, \underline{\mathbf{y}}^{N_f}$  for  $N_f$  given vectors denoted by  $\mathbf{f}^1, \dots, \mathbf{f}^{N_f}$  with  $\mathbf{f}^j$  in  $\mathbb{R}^n$  such that for all  $j$  in  $1, \dots, N_f$ , we have  $[\mathbb{K}]\underline{\mathbf{y}}^j = \mathbf{f}^j$ . Let  $\mathbf{b}^1, \dots, \mathbf{b}^m$  with  $m \leq N_f$  be the orthonormal family in  $\mathbb{R}^n$  deduced from  $\mathbf{f}^1, \dots, \mathbf{f}^{N_f}$  and constructed, for instance, using the Gram-Schmid algorithm. Introducing the  $(n \times N_f)$  real matrices  $[\underline{\mathbf{y}}] = [\underline{\mathbf{y}}^1 \dots \underline{\mathbf{y}}^{N_f}]$  and  $[f] = [\mathbf{f}^1 \dots \mathbf{f}^{N_f}]$  and the  $(n \times m)$  real matrix  $[b] = [\mathbf{b}^1 \dots \mathbf{b}^m]$  whose columns are  $\mathbb{R}^n$  vectors. We then have  $[f] = [b][q]$  in which  $[q]$  is a  $(m \times N_f)$  real matrix. Since  $[b]^T [b] = [I_m]$  in which  $[I_m]$  is the  $(m \times m)$  unity matrix, the  $(m \times N_f)$  real matrix  $[q]$  is given by  $[q] = [b]^T [f]$ . Therefore, we have to solve the equation  $[\mathbb{K}][\underline{\mathbf{y}}] = [f]$  that is equivalent to  $[\underline{\mathbf{y}}] = [\underline{\mathbf{x}}][q]$  in which the  $(n \times m)$  real matrix  $[\underline{\mathbf{x}}]$  is solution of the following matrix equation

$$[\mathbb{K}][\underline{\mathbf{x}}] = [b] \quad . \quad (1)$$

It should be noted that the matrix  $[b]$  has only been introduced to reduce the number of computations to be carried out but that the construction of the random matrix will be independent of  $[b]$ . Below we will only consider Eq. (1). Note that the nonparametric probabilistic approach cannot directly be implemented for the matrix  $[\mathbb{K}]$ . A reduced model has to be introduced and the probability model has to be constructed for the generalized matrix of the reduced model. The main reason is the following. For such a strictly elliptic boundary value problem, the use of the finite element method yields a sparse random matrix  $[\mathbb{K}]$  for which zeros are present in the matrix. It should be noted that it is not clear if a zero could or could not be replaced by a non zero random variable in the context of model uncertainties. In an other hand, some zeros are due to the topology of the geometry of the domain. Consequently, a direct construction of the probability distribution of such random matrices would be very difficult and would require to have solved the two following problems. The first one would consist in defining the zeros in a sparse matrix resulting from the finite element mesh of a given domain for general complex systems and that must remain zeros in the presence of model uncertainties. The second one would consist in constructing the probability distribution of a sparse random matrix  $[\mathbb{K}]$  with values in the set of all the positive-definite  $(n \times n)$  real matrices (1) for which the zeros are given, (2) for which the mean value  $[\mathbb{K}]$  is given and (3) for which the second-order moment of the random variable  $\|[\mathbb{K}]\}^{-1}\|$  is finite in order that the second-order moment of the random response  $[\mathbf{X}]$  such that  $[\mathbb{K}][\mathbf{X}] = [b]$  be finite. This problem is still an open problem and the mathematical difficulties induced for high values of  $n$  (several millions of degrees of freedom) are considerable. Finally, it should be noted that the substitution of the sparse matrix of the mean computational model by a full random matrix  $[\mathbb{K}]$  would absolutely be not reasonable for large computational model (note that if  $n = 10^7$ , then  $[\mathbb{K}]$  would have  $0.5 \times 10^{14}$  non zero elements !). This is the reason why we propose to extend the nonparametric probabilistic approach developed for dynamical systems to the computational models of strictly elliptic boundary value problems in order to take into account both the system parameters uncertainties and the model uncertainties. This means that an efficient reduced mean model must be constructed. It is well known that the modal analysis is very efficient to reduce the computational model in dynamics but is not at

all efficient for static problem (elliptic problem) due to a slow rate of convergence with respect to the dimension of the reduction. We then propose another approach.

## 2. Implementation of the nonparametric probabilistic approach for strictly elliptic boundary value problem

### 2.1. Algebraic notations

In this paper, the following algebraic notations are used.

Matrix sets. Let  $\mathbb{M}_{\mu,\nu}(\mathbb{R})$  be the set of all  $(\mu \times \nu)$  real matrices and  $\mathbb{M}_{\mu}(\mathbb{R}) = \mathbb{M}_{\mu,\mu}(\mathbb{R})$  be the set of all square  $(\mu \times \mu)$  real matrices. Let  $\mathbb{M}_{\mu}^S(\mathbb{R})$  be the set of all  $(\mu \times \mu)$  real symmetric matrices and  $\mathbb{M}_{\mu}^+( \mathbb{R})$  be the set of all  $(\mu \times \mu)$  real symmetric positive-definite matrices.

Euclidean space. Any vector  $\mathbf{v} = (v_1, \dots, v_{\mu})$  in  $\mathbb{R}^{\mu}$  is represented by the column matrix  $\mathbf{v}$  in  $\mathbb{M}_{\mu,1}(\mathbb{R})$  of its components. If  $\mathbf{v}$  and  $\mathbf{w}$  are in  $\mathbb{R}^{\mu}$ , we denote by  $\langle \mathbf{v}, \mathbf{w} \rangle_{\mu} = v_1 w_1 + \dots + v_{\mu} w_{\mu}$  the Euclidean inner product and by  $\|\mathbf{v}\|_{\mu} = \langle \mathbf{v}, \mathbf{v} \rangle_{\mu}^{1/2}$  the associated Euclidean norm.

Matrix operations. The determinant of a matrix  $[A]$  belonging to  $\mathbb{M}_{\mu}(\mathbb{R})$  is denoted by  $\det[A]$  and its trace by  $\text{tr}[A] = \sum_{j=1}^{\mu} [A]_{jj}$ . If  $[A]$  belongs to  $\mathbb{M}_{\mu,\nu}(\mathbb{R})$  and if  $\mathbf{v}$  belongs to  $\mathbb{R}^{\mu}$ , then their transpose are  $[A]^T$  in  $\mathbb{M}_{\nu,\mu}(\mathbb{R})$  and  $\mathbf{v}^T$  in  $\mathbb{M}_{1,\mu}$ . If  $[A]$  is in  $\mathbb{M}_{\mu}(\mathbb{R})$  and is invertible, then  $[A]^{-1}$  is the inverse which is in  $\mathbb{M}_{\mu}(\mathbb{R})$ .

Norms and usual operators. The operator norm of a matrix  $[A]$  belonging to  $\mathbb{M}_{\mu,\nu}(\mathbb{R})$  is  $\|A\| = \sup_{\|\mathbf{v}\|_{\nu} \leq 1} \|[A]\mathbf{v}\|_{\mu}$  in which  $\mathbf{v}$  is in  $\mathbb{R}^{\nu}$ . This norm is such that  $\|[A]\mathbf{v}\|_{\mu} \leq \|A\| \|\mathbf{v}\|_{\nu}$  for all  $\mathbf{v}$  in  $\mathbb{R}^{\nu}$ . If  $[A]$  belongs to  $\mathbb{M}_{\mu,\nu}(\mathbb{R})$ , the Frobenius norm (or Hilbert-Schmidt norm) is  $\|A\|_F$  of  $[A]$  is such that  $\|A\|_F^2 = \text{tr}\{[A]^T[A]\}$ . If  $[A]$  belongs to  $\mathbb{M}_{\mu}(\mathbb{R})$ , then  $\|A\| \leq \|A\|_F \leq \sqrt{\mu} \|A\|$ .

### 2.2. Ensemble $\mathbf{SG}^+$ of random matrices

For the implementation of the nonparametric probabilistic approach we need to introduce the ensemble which has been constructed in [?, ?]. We recall this construction in this subsection.

(i)- *Definition of the ensemble  $\mathbf{SG}^+$ .* This ensemble is defined as the second-order random matrices  $[\mathbf{G}_N]$ , defined on a probability space  $(\mathcal{A}, \mathcal{T}, \mathcal{P})$ , with values in  $\mathbb{M}_N^+(\mathbb{R})$ , such that  $E\{[\mathbf{G}_N]\} = \frac{[\underline{\mathbf{G}}_N]}{N} = \frac{[I_N]}{N}$  where  $[I_N]$  is the  $(N \times N)$  unity matrix and such that  $E\{\|[\mathbf{G}_N]^{-1}\|_F^2\} < +\infty$ . The level of statistical fluctuations of such a random matrix is controlled by the dispersion parameter  $\delta > 0$  defined by  $\delta = \{E\{\|[\mathbf{G}_N] - \frac{[\underline{\mathbf{G}}_N]}{N}\|_F^2\} / \|\frac{[\underline{\mathbf{G}}_N]}{N}\|_F^2\}^{1/2} = \{E\{\|[\mathbf{G}_N] - [I_N]\|_F^2\} / N\}^{1/2}$  and which must be such that  $\delta \in [0, \delta_0[$  with  $\delta_0 = (N+1)^{1/2}(N+5)^{-1/2}$ .

(ii)- *Probability distribution of a random matrix in ensemble  $\mathbf{SG}^+$ .* The probability distribution  $P_{[\mathbf{G}_N]}$  of the random matrix  $[\mathbf{G}_N]$  is defined by a probability density function  $[G_N] \mapsto p_{[\mathbf{G}_N]}([G_N])$  from  $\mathbb{M}_N^+(\mathbb{R})$  into  $\mathbb{R}^+ = [0, +\infty[$ , with respect to the measure (volume element)  $\tilde{d}G_N$  on the set  $\mathbb{M}_N^S(\mathbb{R})$  such that  $\tilde{d}G_N = 2^{N(N-1)/4} \prod_{1 \leq i < j \leq N} d[G_N]_{ij}$ . We then have  $P_{[\mathbf{G}_N]} = p_{[\mathbf{G}_N]}([G_N]) \tilde{d}G_N$  with the normalization condition  $\int_{\mathbb{M}_N^+(\mathbb{R})} p_{[\mathbf{G}_N]}([G_N]) \tilde{d}G_N = 1$ . The

probability density function  $p_{[\mathbf{G}_N]}([G_N])$  is then written as

$$p_{[\mathbf{G}_N]}([G_N]) = \mathbb{1}_{\mathbb{M}_N^+(\mathbb{R})}([G_N]) \times C_{\mathbf{G}_N} \times (\det [G_N])^{(N+1)\frac{(1-\delta^2)}{2\delta^2}} \times \exp \left\{ -\frac{(N+1)}{2\delta^2} \text{tr}[G_N] \right\} \quad , \quad (2)$$

in which  $\mathbb{1}_{\mathbb{M}_N^+(\mathbb{R})}([G_N])$  is equal to 1 if  $[G_N] \in \mathbb{M}_N^+(\mathbb{R})$  and is equal to zero if  $[G_N] \notin \mathbb{M}_N^+(\mathbb{R})$  and where positive constant  $C_{\mathbf{G}_N}$  is such that

$$C_{\mathbf{G}_N} = \frac{(2\pi)^{-N(N-1)/4} \left(\frac{N+1}{2\delta^2}\right)^{N(N+1)(2\delta^2)^{-1}}}{\left\{ \prod_{j=1}^N \Gamma\left(\frac{N+1}{2\delta^2} + \frac{1-j}{2}\right) \right\}} \quad , \quad (3)$$

where  $\Gamma(z)$  is the gamma function defined for  $z > 0$  by  $\Gamma(z) = \int_0^{+\infty} t^{z-1} e^{-t} dt$ . Equation (??) shows that  $\{[G_N]_{jk}, 1 \leq j \leq k \leq N\}$  are dependent random variables. If  $(N+1)/\delta^2$  is an integer, then the probability distribution defined by Eqs. (??) and (??) is a usual Wishart distribution. In general,  $(N+1)/\delta^2$  is not an integer and consequently, the probability distribution defined by Eqs. (??) and (??) is not a usual Wishart distribution.

(iii)- *Algebraic representation for Monte Carlo simulation.* The following algebraic representation of the random matrix  $[\mathbf{G}_N]$  allows a procedure for the Monte Carlo numerical simulation of random matrix  $[\mathbf{G}_N]$  to be defined. The random matrix  $[\mathbf{G}_N]$  can be written as  $[\mathbf{G}_N] = [\mathbf{L}_N]^T [\mathbf{L}_N]$  in which  $[\mathbf{L}_N]$  is an upper triangular random matrix with values in  $\mathbb{M}_N(\mathbb{R})$  such that: (1) the random variables  $\{[\mathbf{L}_N]_{jj'}, j \leq j'\}$  are independent; (2) for  $j < j'$ , the real-valued random variable  $[\mathbf{L}_N]_{jj'}$  can be written as  $[\mathbf{L}_N]_{jj'} = \sigma_N U_{jj'}$  in which  $\sigma_N = \delta(N+1)^{-1/2}$  and where  $U_{jj'}$  is a real-valued Gaussian random variable with zero mean and variance equal to 1; (3) for  $j = j'$ , the positive-valued random variable  $[\mathbf{L}_N]_{jj}$  can be written as  $[\mathbf{L}_N]_{jj} = \sigma_N \sqrt{2V_j}$  in which  $\sigma_N$  is defined above and where  $V_j$  is a positive-valued gamma random variable whose probability density function  $p_{V_j}(v)$  with respect to  $dv$  is written as  $p_{V_j}(v) = \mathbb{1}_{\mathbb{R}^+}(v) \left\{ \Gamma\left(\frac{N+1}{2\delta^2} + \frac{1-j}{2}\right) \right\}^{-1} v^{\frac{N+1}{2\delta^2} - \frac{1+j}{2}} e^{-v}$ .

(iv)- *Convergence property of a random matrix in ensemble  $\mathbf{SG}^+$  when dimension goes to infinity.* It is mathematically proved that  $E\{\|[\mathbf{G}_N]^{-1}\|_F^2\} < +\infty$  and therefore that  $E\{\|[\mathbf{G}_N]^{-1}\|^2\} < +\infty$ . In addition, the following fundamental property is proved: for all  $N \geq 2$ , we have  $E\{\|[\mathbf{G}_N]^{-1}\|^2\} \leq C_\delta < +\infty$  in which  $C_\delta$  is a positive finite constant that is independent of  $N$  but that depends on  $\delta$ . This inequality means that  $N \mapsto E\{\|[\mathbf{G}_N]^{-1}\|^2\}$  is a bounded function from  $\{N \geq 2\}$  into  $\mathbb{R}^+$ .

### 2.3. Effective construction of the probability model

Let  $N \leq n$  be a positive integer. Let  $\varphi^1, \dots, \varphi^N$  be the  $N$  orthonormal eigenvectors of the matrix  $[\mathbb{K}]$  associated with the  $N$  first positive eigenvalues  $0 < \lambda_1 \leq \lambda_2 \leq \dots \leq \lambda_N$  such that  $[\mathbb{K}]\varphi^\alpha = \lambda_\alpha \varphi^\alpha$ . We then have  $\langle \varphi^\alpha, \varphi^\beta \rangle = \delta_{\alpha\beta}$  in which  $\delta_{\alpha\beta} = 0$  if  $\alpha \neq \beta$  and  $\delta_{\alpha\alpha} = 1$ . Let  $[\Phi^N]$  be the matrix in  $\mathbb{M}_{n,N}(\mathbb{R})$  whose columns are  $\varphi^1, \dots, \varphi^N$ . We have

$$[\Phi^N] = [\varphi^1 \dots \varphi^N] \quad , \quad [\Phi^N]^T [\Phi^N] = [I_N] \quad , \quad (4)$$

in which  $[I_N]$  is the  $(N \times N)$  unity matrix. Note that  $[\Phi^N][\Phi^N]^T \neq [I_n]$ . Let  $[\mathbf{X}]$  be the  $\mathbb{M}_{n,m}(\mathbb{R})$ -valued random variable which is the solution of the stochastic computational model associated with the mean computational model defined by Eq. (??) and which is written as

$$[\mathbb{K}][\mathbf{X}] = [b] \quad , \quad (5)$$

in which the probability model of the random matrix  $[\mathbb{K}]$  with values in  $\mathbb{M}_n^+(\mathbb{R})$  must be constructed. Let  $[\underline{x}] \in \mathbb{M}_{n,m}(\mathbb{R})$  be the unique solution of the mean computational model  $[\underline{\mathbb{K}}][\underline{x}] = [b]$  (formally, we have  $[\underline{x}] = [\underline{\mathbb{K}}]^{-1}[b]$ ). The nonparametric probabilistic approach of both system parameters uncertainties and model uncertainties consists in introducing a family  $\{[\mathbb{K}^N], N = 1, \dots, n\}$  of random matrices with values in  $\mathbb{M}_n^+(\mathbb{R})$  such that (1) for all  $N$  in  $\{1, \dots, n\}$ , the  $\mathbb{M}_{n,m}(\mathbb{R})$ -valued random matrix  $[\mathbf{X}^N]$  which is solution of the stochastic equation

$$[\mathbb{K}^N][\mathbf{X}^N] = [b] \quad , \quad (6)$$

must be such that  $E\{\|\mathbf{X}^N\|_F^2\} = c < +\infty$  and (2) in the mean-square sense, we must have  $\lim_{N \rightarrow n} [\mathbf{X}^N] = [\mathbf{X}]$  which means that

$$\lim_{N \rightarrow n} E\{\|\mathbf{X}^N - [\mathbf{X}]\|_F^2\} = 0 \quad , \quad (7)$$

in which  $[\mathbf{X}]$  is the second-order solution of Eq. (??). We then propose as the family of symmetric random matrices the following one

$$[\mathbb{K}^N] = \{[\Phi^N]([\mathbf{K}_N]^{-1} - [\underline{\mathbf{K}}_N]^{-1})[\Phi^N]^T + [\underline{\mathbb{K}}]^{-1}\}^{-1} \quad , \quad (8)$$

in which  $[\underline{\mathbf{K}}_N]$  is the diagonal matrix belonging to  $\mathbb{M}_N^+(\mathbb{R})$  and such that

$$[\underline{\mathbf{K}}_N]_{\alpha\beta} = ([\Phi^N]^T[\underline{\mathbb{K}}][\Phi^N])_{\alpha\beta} = \lambda_\alpha \delta_{\alpha\beta} \quad , \quad (9)$$

which admits the following Cholesky decomposition

$$[\underline{\mathbf{K}}_N] = [\underline{\mathbf{L}}_N]^T[\underline{\mathbf{L}}_N] \quad , \quad [\underline{\mathbf{L}}_N]_{\alpha\beta} = \sqrt{\lambda_\alpha} \delta_{\alpha\beta} \quad . \quad (10)$$

Following the construction proposed in [?, ?, ?], the random matrix  $[\mathbf{K}_N]$  with values in  $\mathbb{M}_N^+(\mathbb{R})$  is written as

$$[\mathbf{K}_N] = [\underline{\mathbf{L}}_N]^T[\mathbf{G}_N][\underline{\mathbf{L}}_N] \quad , \quad (11)$$

in which  $[\mathbf{G}_N]$  is a random matrix with values in  $\mathbb{M}_N^+(\mathbb{R})$ , belonging to the ensemble  $\text{SG}^+$  of random matrices defined in Section 2.2. We then have  $E\{[\mathbf{K}_N]\} = [\underline{\mathbf{K}}_N]$ .

*Comments on the construction proposed.* Introducing the subspace of  $\mathbb{R}^n$  spanned by  $\varphi^1, \dots, \varphi^N$ , the projection of Eq. (??) yields

$$[\tilde{\mathbf{X}}^N] = [\Phi^N][\mathbf{Q}^N] \quad , \quad [\mathbf{K}_N][\mathbf{Q}^N] = [\Phi^N]^T[b] \quad , \quad (12)$$

where  $[\mathbf{K}_N]$  is the random matrix with values in  $\mathbb{M}_N^+(\mathbb{R})$  given by  $[\mathbf{K}_N] = [\Phi^N]^T[\mathbb{K}][\Phi^N]$  and defined by Eq. (??) for which the probability model is completely defined. For  $N \leq n$ , when  $\delta \rightarrow 0$ ,  $[\mathbf{K}_N]^{-1} \rightarrow [\underline{\mathbf{K}}_N]^{-1}$  in probability and consequently,  $[\tilde{\mathbf{X}}^N] \rightarrow [\underline{\mathbf{x}}^N] = [\Phi^N][\underline{\mathbf{K}}_N]^{-1}[\Phi^N]^T[b]$  which differs from the solution  $[\underline{x}]$  of Eq. (??). We then introduce a corrective term allowing the convergence with respect to  $N$  to be increased in writing  $[\mathbf{X}^N] = [\tilde{\mathbf{X}}^N] - [\tilde{\mathbf{X}}^N]_{\delta=0} + [\underline{x}]$ . In this condition, for any value of  $N$ ,  $\lim_{\delta \rightarrow 0} [\mathbf{X}^N] = [\underline{x}]$  in probability and  $[\mathbf{X}^N] = [\Phi^N][\mathbf{K}_N]^{-1}[\Phi^N]^T[b] - [\Phi^N][\underline{\mathbf{K}}_N]^{-1}[\Phi^N]^T[b] + [\underline{x}]$ . Taking into account that  $[\underline{x}] = [\underline{\mathbb{K}}]^{-1}[b]$ , Eq. (??) with Eq. (??) can easily be deduced. As it is proven in Section 2.5 devoted to the fundamental properties of the stochastic model, the introduction of this corrective term allows the rate of convergence to be considerably increased without modifying the fundamental properties of the random matrix.



#### 2.4. Effective computation of the random solution

Let  $[\underline{x}]$  be the solution of Eq. (??). The random solution  $[\mathbf{X}] = \lim_{N \rightarrow n} [\mathbf{X}^N]$  of Eq. (??) is constructed by using the Monte Carlo method. For  $N$  fixed, let  $[\mathbf{G}_N(a_1)], \dots, [\mathbf{G}_N(a_{n_s})]$  be  $n_s$  independent realizations of random matrix  $[\mathbf{G}_N]$  and constructed with the generator given in Section 2.2-(iii). For every  $\ell$  fixed in  $\{1, \dots, n_s\}$ , the realization  $[\mathbf{X}^N(a_\ell)]$  is constructed by solving the following deterministic equations derived from Eqs. (??) and (??) to (??),

$$[\mathbb{K}^N(a_\ell)] [\mathbf{X}^N(a_\ell)] = [b] \quad , \quad (13)$$

$$[\mathbb{K}^N(a_\ell)] = \{[\Phi^N]([\mathbf{K}_N(a_\ell)]^{-1} - [\underline{\mathbb{K}}_N]^{-1})[\Phi^N]^T + [\underline{\mathbb{K}}]^{-1}\}^{-1} \quad , \quad (14)$$

$$[\mathbf{K}_N(a_\ell)] = [\underline{\mathbb{L}}_N]^T [\mathbf{G}_N(a_\ell)] [\underline{\mathbb{L}}_N] \quad . \quad (15)$$

The matrix  $[\mathbb{K}^N(a_\ell)]$  which is a full matrix is never assembled and the algorithm to compute  $[\mathbf{X}^N(a_\ell)]$  is the following:

*Step 1* (outside the Monte Carlo loop on  $\ell$ ): Compute  $[\underline{x}]$  in solving the deterministic linear matrix equation  $[\underline{\mathbb{K}}][\underline{x}] = [b]$ . Then compute  $[\underline{x}^N] = [\Phi^N][\underline{q}^N]$  in which  $[\underline{q}^N]$  is calculated in solving the deterministic equation  $[\underline{\mathbb{K}}_N][\underline{q}^N] = [\Phi^N]^T [b]$  which is such that  $[\underline{q}^N]_{\alpha j} = \lambda_\alpha^{-1} \sum_{k=1} [\Phi^N]_{k\alpha} [b]_{kj}$  for  $\alpha = 1, \dots, N$  and for  $j = 1, \dots, m$ .

*Step 2* (inside the Monte Carlo loop on  $\ell$ ): Compute  $[\tilde{\mathbf{X}}^N(a_\ell)] = [\Phi^N][\mathbf{Q}^N(a_\ell)]$  in which  $[\mathbf{Q}^N(a_\ell)]$  is calculated in solving the deterministic matrix equation  $[\mathbf{K}_N(a_\ell)][\mathbf{Q}^N(a_\ell)] = [\Phi^N]^T [b]$ . Then compute  $[\mathbf{X}^N(a_\ell)] = [\tilde{\mathbf{X}}^N(a_\ell)] - [\underline{x}^N] + [\underline{x}]$ .

*Step 3* (outside the Monte Carlo loop on  $\ell$ ): Perform the mean-square convergence analysis with respect to the order  $N$  of the reduction and with respect to the number  $n_s$  of realizations in constructing the graph of the function  $(N, n_s) \mapsto \text{Conv}(N, n_s)$  such that

$$\text{Conv}(N, n_s) = \left\{ n_s^{-1} \sum_{\ell=1}^{n_s} \|\mathbf{X}^N(a_\ell)\|_b^2 \right\}^{1/2} \quad , \quad \|\mathbf{X}^N(a_\ell)\|_b^2 = m^{-1} \|\mathbf{X}^N(a_\ell)\|_F^2 \quad . \quad (16)$$

#### 2.5. Fundamental properties of the stochastic model

The fundamental mathematical properties of the stochastic model constructed are summarized in the four following propositions.

*Proposition 1.* The random matrix  $[\mathbb{K}^N]$  is a symmetric matrix and is a random variable with values in  $\mathbb{M}_n^+(\mathbb{R})$ .

*Proof.* It can easily be verified that the random matrix  $[\mathbb{K}^N]$  is symmetric. To prove the second part of this proposition, it is sufficient to prove that  $[\mathbb{A}] = [\mathbb{K}^N]^{-1}$  is a random matrix with values in  $\mathbb{M}_n^+(\mathbb{R})$  in which  $[\mathbb{A}] = [\Phi^N]([\mathbf{K}_N]^{-1} - [\underline{\mathbb{K}}_N]^{-1})[\Phi^N]^T + [\underline{\mathbb{K}}]^{-1}$  and where  $[\underline{\mathbb{K}}_N] = [\lambda_N]$  with  $[\lambda_N]_{\alpha\beta} = \lambda_\alpha \delta_{\alpha\beta}$ . From Eq. (??), it can be deduced that

$$[\Phi^N]^T [\underline{\mathbb{K}}] [\Phi^N] = [\lambda_n] = \begin{bmatrix} [\lambda_N] & [0] \\ [0] & [\lambda_{n-N}] \end{bmatrix} \quad ,$$

in which  $[\lambda_{n-N}]$  is the diagonal matrix of the positive eigenvalues  $\lambda_{N+1} \leq \dots \leq \lambda_n$ . In addition, if the random matrix  $[\mathbb{B}] = [\Phi^N]^T [\mathbb{A}] [\Phi^N]$  is with values in  $\mathbb{M}_n^+(\mathbb{R})$ , then  $[\mathbb{A}]$  will be

in values in  $\mathbb{M}_n^+(\mathbb{R})$ . Since  $[\Phi^N]^T [\Phi^N] = [[I_N] [0_{N,n-N}]]$  in which  $[0_{N,n-N}]$  is the  $(N \times (n-N))$  zero matrix, it can easily be verified that

$$[\mathbb{B}] = \begin{bmatrix} [\mathbf{K}_N]^{-1} & [0] \\ [0] & [\lambda_{n-N}]^{-1} \end{bmatrix} .$$

Since  $[\mathbf{K}_N]^{-1}$  is a random matrix with values in  $\mathbb{M}_N^+(\mathbb{R})$  and since  $[\lambda_{n-N}]^{-1}$  belongs to  $\mathbb{M}_{n-N}^+(\mathbb{R})$ , it can be deduce that  $[\mathbb{B}]$  is a random matrix with values in  $\mathbb{M}_n^+(\mathbb{R})$ .

*Proposition 2.* The random matrix  $[\mathbb{K}^N]$  being a random variable with values in  $\mathbb{M}_n^+(\mathbb{R})$ ,  $[\mathbb{K}^N]$  is almost surely invertible but in addition, for any  $N$  in  $\{1, \dots, n\}$  and for any  $\delta$  in  $[0, \delta_0[$ , there is a positive finite constant  $c_{N,\delta}$  depending on  $N$  and  $\delta$  such that

$$E\{\|[\mathbb{K}^N]^{-1}\|^2\} = c_{N,\delta} < +\infty . \quad (17)$$

*Proof.* Eq. (??) yields  $[\mathbb{K}^N]^{-1} = [\Phi^N]([\mathbf{K}_N]^{-1} - [\underline{\mathbf{K}}_N]^{-1})[\Phi^N]^T + [\underline{\mathbf{K}}]^{-1}$ . From Eq. (??), it can be deduced that  $[\mathbf{K}_N]^{-1} = [\underline{\mathbf{L}}_N]^{-1}[\mathbf{G}_N]^{-1}[\underline{\mathbf{L}}_N]^{-T}$ . Since  $[\mathbf{G}_N]$  belongs to  $\mathbf{SG}^+$ , we have  $E\{\|[\mathbf{G}_N]^{-1}\|^2\} = c_\delta < +\infty$  in which the constant  $c_\delta$  depends on  $\delta$  but is independent of  $N$ . From the inequalities  $\|[\mathbf{K}_N]^{-1}\| \leq \|[\underline{\mathbf{L}}_N]^{-1}\| \|[\mathbf{G}_N]^{-1}\| \|[\underline{\mathbf{L}}_N]^{-T}\|^2$  and  $\|[\mathbb{K}^N]^{-1}\| = \|[\Phi^N]\| \|[\Phi^N]^T\| (\|[\mathbf{K}_N]^{-1}\| + \|[\underline{\mathbf{K}}_N]^{-1}\|) + \|[\underline{\mathbf{K}}]^{-1}\|$ , we deduce that  $\|[\mathbb{K}^N]^{-1}\| \leq \alpha_N \|[\mathbf{G}_N]^{-1}\| + \beta_N$  in which  $\alpha_N$  and  $\beta_N$  are two positive finite constants which depend on  $N$ . Then the inequality  $(a+b)^2 \leq 2(a^2 + b^2)$  for  $a \geq 0$  and  $b \geq 0$  yields  $\|[\mathbb{K}^N]^{-1}\|^2 \leq 2(\alpha_N^2 \|[\mathbf{G}_N]^{-1}\|^2 + \beta_N^2)$  and consequently, we obtain Eq. (??).

*Proposition 3.* For any  $N$  in  $\{1, \dots, n\}$  and for any  $\delta$  in  $[0, \delta_0[$ , the random equation  $[\mathbb{K}^N][\mathbf{X}^N] = [b]$  has a unique second-order solution  $[\mathbf{X}^N]$ , that is to say, there is a positive finite constant  $\tilde{c}_{N,\delta}$  depending on  $N$  and  $\delta$  such that

$$E\{\|[\mathbf{X}^N]\|_F^2\} = \tilde{c}_{N,\delta} < +\infty . \quad (18)$$

*Proof.* From Proposition 1,  $[\mathbb{K}^N]$  is invertible almost surely and consequently,  $[\mathbf{X}^N] = [\mathbb{K}^N]^{-1}[b]$  which yields  $\|[\mathbf{X}^N]\|_F^2 = \|[\mathbb{K}^N]^{-1}\|^2 \| [b] \|_F^2$ . Using Eq. (??), we deduce Eq. (??) with  $\tilde{c}_{N,\delta} = c_{N,\delta} \| [b] \|_F^2$ .

*Proposition 4.* The random matrix  $[\mathbb{K}]$  in equation  $[\mathbb{K}][\mathbf{X}] = [b]$  (see Eq. (??)) is defined as  $[\mathbb{K}] = [\mathbb{K}^N] = \lim_{N \rightarrow n} [\mathbb{K}^N]$  and consequently, we have  $[\mathbf{X}] = [\mathbf{X}^N] = \lim_{N \rightarrow n} [\mathbf{X}^N]$  and  $\lim_{N \rightarrow n} E\{\|[\mathbf{X}^N] - [\mathbf{X}]\|_F^2\} = 0$  (see Eq. (??)). For any fixed value of  $N$  in  $\{1, \dots, n\}$ , we have  $[\mathbf{X}^N] \rightarrow [\underline{\mathbf{x}}]$  in probability when  $\delta \rightarrow 0$ .

*Proof.* For  $N = n$ , Eq. (??) yields  $[\mathbb{K}^n][\mathbf{X}^n] = [b]$ . Defining the random matrix  $[\mathbb{K}]$  as  $[\mathbb{K}] = [\mathbb{K}^n]$ , we deduce that  $[\mathbb{K}][\mathbf{X}^n] = [b]$ . Since  $[\mathbf{X}]$  is such that  $[\mathbb{K}][\mathbf{X}] = [b]$  (see Eq. (??)), we then deduce that  $[\mathbf{X}] = [\mathbf{X}^n]$  almost surely. Since  $[\mathbb{K}] = [\mathbb{K}^n]$ , the equation  $[\mathbb{K}][\mathbf{X}] = [b]$  (see Eq. (??)) has a unique second-order solution and since for all  $N$  in  $\{1, \dots, n\}$ ,  $[\mathbf{X}^N]$  is a second-order random variable (see Eq. (??)), then Eq. (??) holds. The last fundamental property can directly be deduced from the comment given at the end of Section 2.3 which is  $[\mathbf{K}_N]^{-1} \rightarrow [\underline{\mathbf{K}}_N]^{-1}$  in probability when  $\delta \rightarrow 0$  and then  $[\mathbb{K}^N]^{-1} \rightarrow [\underline{\mathbf{K}}]^{-1}$  in probability when  $\delta \rightarrow 0$ .

### 3. Application and validation

In this Section, we present a validation of the previous theory for a strictly elliptic boundary value problem corresponding to a linear elastostatic problem of a three-dimensional bounded medium.

#### 3.1. Geometry, material, boundary conditions and external loads

The computational domain is a thick circular cylindrical shell referred to a cartesian reference system  $(0, x, y, z)$  and to the associated cylindrical coordinate system  $(0, r, \theta, z)$  as shown in Fig. 1. The internal radius is  $r_1 = 3$  m, the external radius is  $r_2 = 6$  m and the length is  $L_z = 4$  m. This domain is occupied by a material whose mean model is a linear elastic isotropic and homogeneous material with Young's modulus  $2 \times 10^9$  N/m<sup>2</sup> and Poisson's coefficient 0.15. The displacement field is locked (zero Dirichlet conditions) on the surface  $\mathcal{S}_0$  defined by  $\mathcal{S}_0 = \{(r, \theta, z) : r = r_2, \theta \in [-2\pi/64, +2\pi/64], z \in [0, L_z]\}$ . Let  $\mathcal{S}_1$  be the external lateral surface of the cylinder on which external static loads are applied and which is defined by  $\mathcal{S}_1 = \{(r, \theta, z) : r = r_2, \theta \in ]2\pi/64, 2\pi - 2\pi/64[, z \in [0, L_z]\}$ . The external static loads are constituted of the  $N_f = 64$  forces fields defined for all  $j = 1, \dots, N_f$  by  $\mathbf{g}^j(r, \theta, z) = (g_x^j(r, \theta, z), g_y^j(r, \theta, z), g_z^j(r, \theta, z))$  with  $(r, \theta, z) \in \mathcal{S}_1$  in which  $g_x^j(r, \theta, z) = c(\theta, z, j) \cos(\theta)$ ,  $g_y^j(r, \theta, z) = c(\theta, z, j) \sin(\theta)$  and  $g_z^j(r, \theta, z) = c(\theta, z, j)$  with  $c(\theta, z, j) = \cos(\pi z/L_z - p_j) \cos(2(\theta - p_j))$  and where  $p_j = 2\pi(j - 1)/N_f$ .

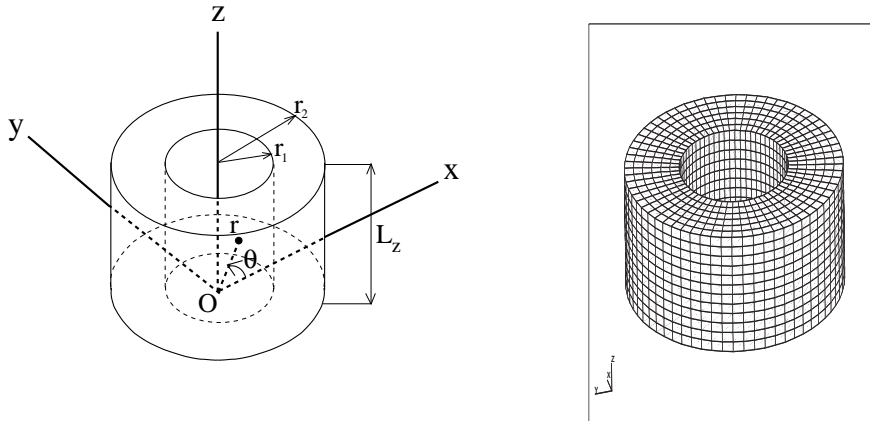

Figure 1. Geometry of the domain and coordinate systems (left figure). Finite element mesh of the domain (right figure).

#### 3.2. Computational model

The mean computational model is made up of a  $6 \times 64 \times 12$  finite element mesh in  $(r, \theta, z)$  (see Fig. 1) with 3D 8-nodes solid finite elements, 5824 nodes, 39 nodes with zero Dirichlet conditions and has a total of  $n = 17,355$  degrees of freedom. The finite element discretization of the external static fields  $\mathbf{g}^j$  for  $j = 1, \dots, N_f$  yields the  $N_f$  static loads  $\mathbf{f}^1, \dots, \mathbf{f}^{N_f}$ . These static loads belong to the vector space of dimension  $m = 4$  spanned by the orthonormal

vectors  $\mathbf{b}^1, \dots, \mathbf{b}^m$  in  $\mathbb{R}^n$  deduced from the use of the Gram-Schmid algorithm on the family  $\mathbf{f}^1, \dots, \mathbf{f}^{N_f}$ . The stochastic computational model is constructed with the theory presented in Section 2. Five calculations have been carried out for the values 0.1, 0.2, 0.3, 0.4 and 0.5 of the dispersion parameter  $\delta$  which control the level of uncertainties. The Monte Carlo method is used with  $n_s = 20,000$  for which the mean-square convergence is reached for all the considered values of  $\delta$ . Let  $\mathbf{W}(a_1), \dots, \mathbf{W}(a_{n_s})$  be  $n_s$  independent realizations of any random variable  $\mathbf{W}$  defined on the probability space  $(\mathcal{A}, \mathcal{T}, \mathcal{P})$  and relative to the random response of the stochastic system. We then use the following statistical estimation  $E\{\mathbf{W}\} \simeq n_s^{-1} \sum_{\ell=1}^{n_s} \mathbf{W}(a_\ell)$  and the mean-square convergence is analyzed in studying the function  $n_s \mapsto n_s^{-1} \sum_{\ell=1}^{n_s} \|\mathbf{W}(a_\ell)\|^2$ .

### 3.3. Convergence analysis with respect to parameter $N$

For each given value of the parameter  $N$ , let  $[\mathbf{X}^N]$  be the solution of the stochastic computational equation which is a random matrix defined on  $(\mathcal{A}, \mathcal{T}, \mathcal{P})$  with values in  $\mathbb{M}_{n,m}(\mathbb{R})$ . The mean convergence and the mean-square convergence are analyzed with respect to parameter  $N$ . We then introduce the following functions  $N \mapsto Conv_1(N) = m^{-1/2} \|E\{[\mathbf{X}^N]\}\|_F$  and  $N \mapsto Conv_2(N) = m^{-1/2} \{E\{\|[\mathbf{X}^N]\|_F^2}\}^{1/2}$ . It should be noted that the mean-square convergence ( $Conv_2$ ) implies the convergence in mean ( $Conv_1$ ). Using the above statistical estimation of the mathematical expectation with  $n_s$  independent realizations, we have  $Conv_2(N) = Conv(N, n_s)$  in which  $Conv(N, n_s)$  is defined by Eq. (??). In addition, the speed of the mean-square convergence decreases with  $\delta$  is increasing. We then present the convergence analysis for the largest value of  $\delta$ , that is to say for  $\delta = 0.5$ . Figure 2 displays the graph of  $N \mapsto Conv_1(N)$  in  $\log_{10}$  scale for  $N$  and the graph of  $N \mapsto Conv_2(N)$ . These two figures show that a reasonable convergence is reached for  $N \geq 300$ .

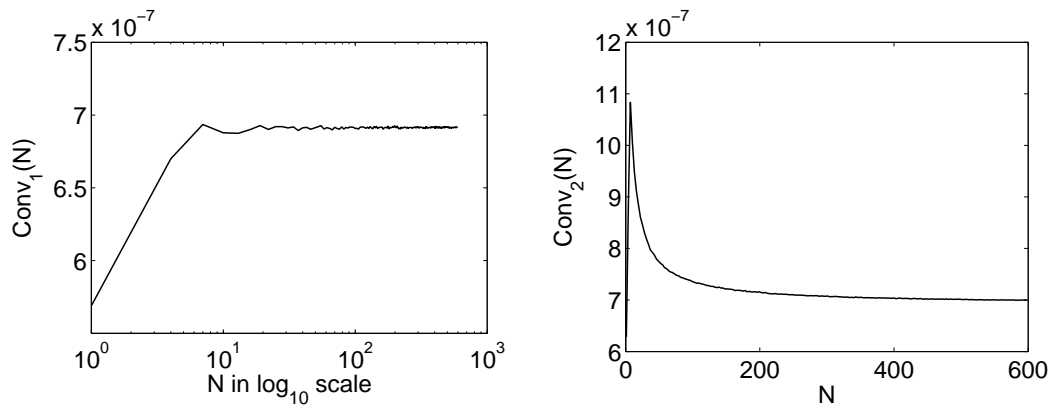

Figure 2. Mean convergence and mean-square convergence with respect to parameter  $N$ : graph of  $N \mapsto Conv_1(N)$  (left figure) and graph of  $N \mapsto Conv_2(N)$  (right figure)

### 3.4. Stochastic response analysis

In this section, the stochastic response analysis is presented for  $N = 500$ . Let  $[\mathbf{X}^N]$  be the random solution with values in  $\mathbb{M}_{n,m}(\mathbb{R})$  for this fixed value of  $N$ . First we introduce two real random observations and then we present the probability distributions of these two random

variables for the five values of  $\delta$ .

Let  $[\underline{\mathbf{X}}^N] = E\{[\mathbf{X}^N]\} \in \mathbb{M}_{n,m}(\mathbb{R})$  be the mean value of the random solution  $[\mathbf{X}^N]$ . Let  $j_1$  and  $k_1$  be the integers such that  $(j_1, k_1) = \arg \max_{j,k} [\underline{\mathbf{X}}^N]_{jk}$ . We then introduce the first random observation as the real-valued random variable  $U = [\mathbf{X}^N]_{j_1 k_1}$ . The random variable  $U$  represents the component of the random response for which the mean value is the largest. The cumulative distribution function of the random variable  $U$  is the function  $u \mapsto F_U(u) = \text{Proba}\{U \leq u\}$  and its probability density function is  $u \mapsto p_U(u) = dF_U(u)/du$ .

Let  $[\sigma^N]$  be the matrix in  $\mathbb{M}_{n,m}(\mathbb{R})$  such that for all  $j$  and  $k$  we have  $[\sigma^N]_{jk}^2 = E\{[\mathbf{X}^N]_{jk}^2 - [\underline{\mathbf{X}}^N]_{jk}^2\}$ . Let  $j_2$  and  $k_2$  be the integers such that  $(j_2, k_2) = \arg \max_{j,k} [\sigma^N]_{jk}$ . We then introduce the second random observation as the real-valued random variable  $V = [\mathbf{X}^N]_{j_2 k_2}$ . The random variable  $V$  represents the component of the random response for which the standard deviation is the largest. The cumulative distribution function of the random variable  $V$  is the function  $v \mapsto F_V(v) = \text{Proba}\{V \leq v\}$  and its probability density function is  $v \mapsto p_V(v) = dF_V(v)/dv$ .

Let  $U(a_1), \dots, U(a_{n_s})$  and  $V(a_1), \dots, V(a_{n_s})$  be  $n_s$  independent realizations of the random variables  $U$  and  $V$  calculated with the stochastic computational model. The cumulative distributions functions  $F_U$  and  $F_V$ , and the probability density functions  $p_U$  and  $p_V$  are usually estimated with the mathematical statistics (see [?]). Figure 3 displays the graphs of functions  $u \mapsto \log_{10} p_U(u)$  and  $v \mapsto \log_{10} p_V(v)$  for  $\delta = 0.1, 0.2, 0.3, 0.4$  and  $0.5$ . These figures show that the random variables  $U$  and  $V$  are closed to Gaussian random variables but are not Gaussian. For instance, Figure 4 shows the comparison of  $v \mapsto \log_{10} p_V(v)$  with a fitted Gaussian probability density function  $v \mapsto \log_{10} p_V^{\text{Gauss}}(v)$  for  $\delta = 0.1$ . Finally, Figure 5 displays the graphs of functions  $u \mapsto \log_{10} F_U(u)$  and  $v \mapsto \log_{10} F_V(v)$  for  $\delta = 0.1, 0.2, 0.3, 0.4$  and  $0.5$ .

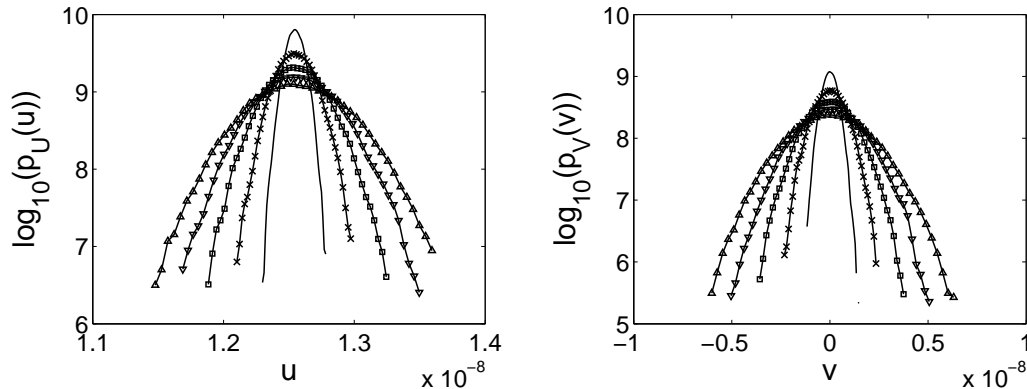

Figure 3. Graph of  $u \mapsto \log_{10} p_U(u)$  (left figure) and graph of  $v \mapsto \log_{10} p_V(v)$  (right figure) for  $\delta = 0.1$  (solid line without symbol),  $\delta = 0.2$  (x-mark symbol),  $\delta = 0.3$  (square symbol),  $\delta = 0.4$  (down triangle symbol),  $\delta = 0.5$  (up triangle symbol).

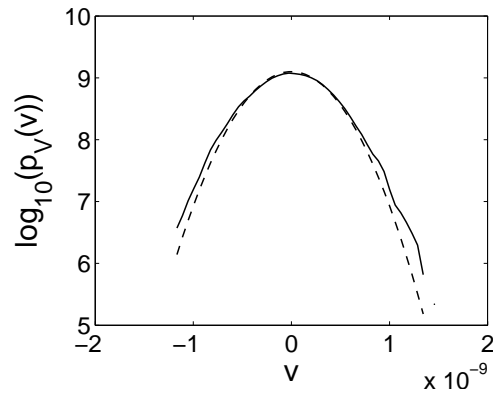

Figure 4. For  $\delta = 0.1$ , graphs of  $v \mapsto \log_{10} p_V(v)$  (solid line) and  $v \mapsto \log_{10} p_V^{Gauss}(v)$  (dashed line).

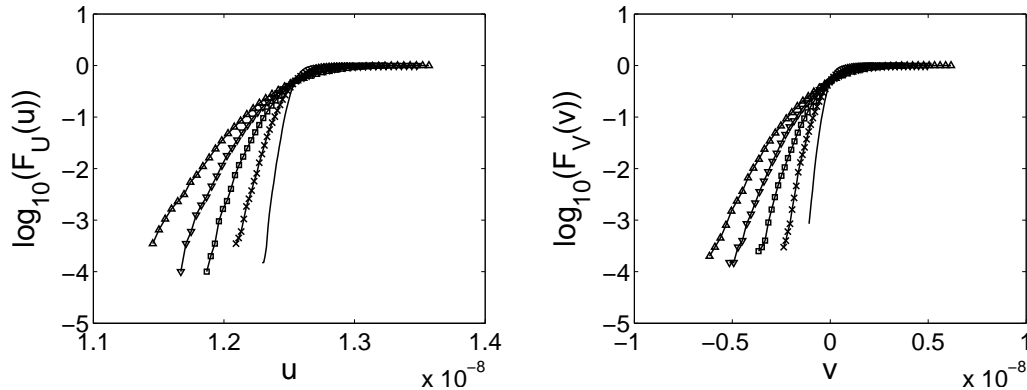

Figure 5. Graph of  $u \mapsto \log_{10} F_U(u)$  (left figure) and graph of  $v \mapsto \log_{10} F_V(v)$  (right figure) for  $\delta = 0.1$  (solid line without symbol),  $\delta = 0.2$  (x-mark symbol),  $\delta = 0.3$  (square symbol),  $\delta = 0.4$  (down triangle symbol),  $\delta = 0.5$  (up triangle symbol).

#### 4. Conclusions

We have presented an extension of the nonparametric probabilistic approach of both system parameters uncertainties and model uncertainties for strictly elliptic boundary value problem. The method proposed introduces two parameters. The first one is the dispersion parameter which allows the level of uncertainties to be controlled. This parameter must be (1) either identified with experiments, for instance using the methodology proposed in [?] (2) or fixed to a given value relative to an expertise (3) or considered as a super parameter to carry out a sensitivity analysis (as we have presented in Section 3). The second parameter is  $N$  and is relative to the construction of the probabilistic approach. The value of  $N$  must be derived from a convergence analysis for each given application. The application presented shows that the convergence is speed enough and that the additional numerical cost is low. Finally, the

theory presented can be extended without any difficulties to elliptic boundary value problems (for instance the linear elastostatic problem with rigid body displacements).

## REFERENCES

1. Soize C. A nonparametric model of random uncertainties for reduced matrix models in structural dynamics. *Probabilistic Engineering Mechanics* 2000; **15**(3):277-294.
2. Mace RR, Worden W, Manson G. (editors). Uncertainty in structural dynamics. *Special issue of the Journal of Sound and Vibration* (2005); **288**(3):431-790.
3. Schueller GI (editor). Computational methods in stochastic mechanics and reliability analysis. *Special issue of Computer Methods in Applied Mechanics and Engineering* (2005); **194**(12-16):1251-1795.
4. Wiener N. The Homogeneous Chaos. *American Journal of Mathematics* 1938; **60**: 897-936.
5. Spanos PD, Ghanem R. Stochastic finite element expansion for random media. *Journal of Engineering Mechanics, ASCE* 1989; **115**(5):1035-1053.
6. Ghanem R, Spanos PD. *Stochastic Finite Elements: A spectral Approach*. Springer-Verlag: New York, 1991.
7. Ghanem R. Ingredients for a general purpose stochastic finite elements formulation. *Computer Methods in Applied Mechanics and Engineering* 1999; **168**:19-34.
8. Ghanem R. Stochastic finite elements with multiple random non-Gaussian properties. *Journal of Engineering Mechanics - ASCE* (1999); **125**(1): 26-40.
9. Ghanem R, Red-Horse J. Propagation of probabilistic uncertainty in complex physical systems using a stochastic finite element approach. *Physica D* (1999); **133**(1-4): 137-144.
10. Ghanem R, Romeo F. A wavelet-based approach for model and parameter identification of non-linear systems. *International Journal of Non-Linear Mechanics* (2001); **36**(5): 835-859.
11. Ghanem R, Pellissetti M. Adaptive data refinement in the spectral stochastic finite element method. *Communications in Numerical Methods in Engineering* (2002); **18**(2): 141-151.
12. Ghanem R, Sarkar A. Reduced models for the medium-frequency dynamics of stochastic systems. *Journal of the Acoustical Society of America*(2003); **113**(2): 834-846.
13. Le Maitre OP, Knio OM. A stochastic particle-mesh scheme for uncertainty propagation in vortical flows. *Journal of Computational Physics* (2007); **226**(1): 645-671.
14. Le Maitre OP, Najm HN, Pebay PP, et al. Multi-resolution-analysis scheme for uncertainty quantification in chemical systems. *SIAM Journal on Scientific Computing* (2007); **29**(2): 864-889.
15. Le Maitre OP, Knio OM, Najm HN, et al. Uncertainty propagation using Wiener-Haar expansions. *Journal of Computational Physics* (2004); **197**(1): 28-57.
16. Le Maitre OP, Najm HN, Ghanem RG, et al. Multi-resolution analysis of Wiener-type uncertainty propagation schemes. *Journal of Computational Physics* (2004); **197**(2): 502-531.
17. Ghanem R, Masri S, Pellissetti M, et al. Identification and prediction of stochastic dynamical systems in a polynomial chaos basis. *Computer Methods in Applied Mechanics and Engineering* (2005); **194**(12-16): 1641-1654.
18. Soize C, Ghanem R. Physical systems with random uncertainties : Chaos representation with arbitrary probability measure. *SIAM Journal On Scientific Computing* 2004; **26**(2):395-410.
19. Desceliers C, Ghanem R, Soize C. Maximum likelihood estimation of stochastic chaos representations from experimental data. *International Journal for Numerical Methods in Engineering* (2006); **66**(6): 978-1001.
20. Desceliers C, Soize C, Ghanem R. Identification of chaos representations of elastic properties of random media using experimental vibration tests. *Computational Mechanics* (2007); **39**(6): 831-838.
21. Babuska I, Tempone R, Zouraris GE. Solving elliptic boundary value problems with uncertain coefficients by the finite element method: the stochastic formulation. *Computer Methods in Applied Mechanics and Engineering* (2005); **194**(12-16): 1251-1294.
22. Soize C. Non Gaussian positive-definite matrix-valued random fields for elliptic stochastic partial differential operators. *Computer Methods in Applied Mechanics and Engineering* (2006); **195**:26-64.
23. Soize C. A comprehensive overview of a non-parametric probabilistic approach of model uncertainties for predictive models in structural dynamics. *Journal of Sound and Vibration* (2005); **288**(3), 623-652.
24. Soize C. Probabilistic models for computational stochastic mechanics and applications, pp.23-42 in *Structural Safety and Reliability ICOSSAR'05*, ed. G. Augusti, G.I. Schueller and M. Ciampoli, ISBN 90 5966 040 4. Millpress: Rotterdam, 2005.
25. Shannon CE. A mathematical theory of communication. *Bell System Technology Journal* 1948; **27**:379-423 & 623-659.
26. Jaynes ET. Information theory and statistical mechanics. *Physical Review* 1957; **106**(4):620-630 & **108**(2):171-190.

27. Serfling RJ. *Approximation Theorems of Mathematical Statistics*. John Wiley & Sons: New York, 1980.
28. Kapur JN, Kesavan HK. *Entropy Optimization Principles with Applications*. Academic Press: San Diego, 1992.
29. Jumarie G. *Maximum Entropy, Information Without Probability and Complex Fractal*. Kluwer Academic Publishers: Dordrecht, 2000.
30. Mehta ML. *Random Matrices*, Revised and Enlarged Second Edition. Academic Press: New York, 1991.
31. Anderson TW. *Introduction to Multivariate Statistical Analysis*. John Wiley & Sons: New York, 1958.
32. Soize C. Maximum entropy approach for modeling random uncertainties in transient elastodynamics. *Journal of the Acoustical Society of America* 2001; **109**(5):1979–1996.
33. Soize C. Random matrix theory and non-parametric model of random uncertainties in vibration analysis. *Journal of Sound and Vibration* (2003); **263**, 893–916.
34. Mignolet MP, Soize C. Nonparametric stochastic modeling of linear systems with prescribed variance of several natural frequencies. *Probabilistic Engineering Mechanics* (2008); **23**(2-3), 267–278.
35. Soize C. Uncertain dynamical systems in the medium-frequency range. *Journal of Engineering Mechanics* (2003); **129**(9), 1017–1027.
36. Soize C, Chebli H. Random uncertainties model in dynamic substructuring using a nonparametric probabilistic model. *Journal of Engineering Mechanics* (2003); **129**(4), 449–457.
37. Chebli H, Soize C. Experimental validation of a nonparametric probabilistic model of non homogeneous uncertainties for dynamical systems. *Journal of the Acoustical Society of America* (2004); **115**(2), 697–705.
38. Duchereau J, Soize C. Transient dynamics in structures with nonhomogeneous uncertainties induced by complex joints. *Mechanical Systems and Signal Processing* (2006); **20**, 854–867.
39. Capiez-Lernout E, Soize C. Nonparametric modeling of random uncertainties for dynamic response of mistuned bladed disks. *Journal of Engineering for Gas Turbines and Power* (2004); **126**(4), 600–618.
40. Capiez-Lernout E, Soize C, Lombard JP, Dupont C, Seinturier E. Blade manufacturing tolerances definition for a mistuned industrial bladed disk. *Journal of Engineering for Gas Turbines and Power* (2005); **127**(3), 621–628.
41. Cottreau R, Clouteau D, Soize C. Probabilistic nonparametric model of impedance matrices. Application to the seismic design of a structure. *European Journal of Computational Mechanics* (2006); **15**(1-2-3), 131–142.
42. Cottreau R, Clouteau D, Soize C. Construction of a probabilistic model for impedance matrices. *Computer Methods in Applied Mechanics and Engineering* (2007); **196**(17-20), 2252–2268.
43. Mignolet MP, Soize C. Nonparametric stochastic modeling of structural dynamic systems with uncertain boundary conditions. AIAA Conference, Schaumburg (Chicago), Illinois, USA, 7-10 April 2008.
44. Capiez-Lernout E, Pellissetti M, Pradlwarter H, Schueller GI, Soize C. Data and model uncertainties in complex aerospace engineering systems. *Journal of Sound and Vibration* (2006); **295**(3-5), 923–938.
45. Soize C. Random matrix theory for modeling uncertainties in computational mechanics. *Computer Methods in Applied Mechanics and Engineering* 2005; **194**(12-16):1333–1366.
46. Chebli H, Soize C. Experimental validation of a nonparametric probabilistic model of non homogeneous uncertainties for dynamical systems. *Journal of the Acoustical Society of America* (2004); **115**(2), 697–705.
47. Chen C, Duhamel D, Soize C. Probabilistic approach for model and data uncertainties and its experimental identification in structural dynamics: Case of composite sandwich panels. *Journal of Sound and vibration* (2006); **294**, 64–81.
48. Arnst M, Clouteau D, Chebli H, Othman R, Degrande G. A nonparametric probabilistic model for ground-borne vibrations in buildings. *Probabilistic Engineering Mechanics* (2006); **21**(1), 18–34.
49. Soize C, Capiez-Lernout E, Durand JF, Fernandez C, Gagliardini L. Probabilistic model identification of uncertainties in computational models for dynamical systems and experimental validation. *Computer Methods in Applied Mechanics and Engineering* (2008); **198**(1), 150–163.
50. Durand JF. *Modélisation de véhicules automobiles en vibroacoustique numérique avec incertitudes de modélisation et validation expérimentale*. Université Paris-Est Marne-la-Vallée, Doctoral thesis, 2007.
51. Capiez-Lernout E, Soize C. Design optimization with an uncertain vibroacoustic model. *ASME Journal of Vibration and Acoustics* (2008); **130**(2), art. no. 021001, 1–8.
52. Durand JF, Soize C, Gagliardini L. Structural-acoustic modeling of automotive vehicles in presence of uncertainties and experimental identification and validation. *Journal of the Acoustical Society of America* (2008); **124**(3), 1513–1525.
53. Desceliers C, Soize C, Cambier S. Non-parametric - parametric model for random uncertainties in nonlinear structural dynamics - Application to earthquake engineering. *Earthquake Engineering and Structural Dynamics* (2004); **33**(3), 315–327.
54. Sampaio R, Soize C. On measures of non-linearity effects for uncertain dynamical systems - Application to a vibro-impact system. *Journal of Sound and Vibration* (2007); **303**(3-5), 659–674.
55. Mignolet MP, Soize C. Stochastic reduced order models for uncertain nonlinear dynamical systems. *Computer Methods in Applied Mechanics and Engineering* (2008); **197**(45-48), 3951–3963.