



HAL
open science

Heuristic for the preemptive asymmetric stacker crane problem

Hervé Kerivin, Mathieu Lacroix, Alain Quilliot, H el ene Toussaint

► **To cite this version:**

Herv e Kerivin, Mathieu Lacroix, Alain Quilliot, H el ene Toussaint. Heuristic for the preemptive asymmetric stacker crane problem. *Electronic Notes in Discrete Mathematics*, 2010, 36, pp.Pages 41-48. 10.1016/j.endm.2010.05.006 . hal-00678520

HAL Id: hal-00678520

<https://hal.science/hal-00678520>

Submitted on 13 Mar 2012

HAL is a multi-disciplinary open access archive for the deposit and dissemination of scientific research documents, whether they are published or not. The documents may come from teaching and research institutions in France or abroad, or from public or private research centers.

L'archive ouverte pluridisciplinaire **HAL**, est destin ee au d ep ot et  a la diffusion de documents scientifiques de niveau recherche, publi es ou non,  emanant des  tablissements d'enseignement et de recherche fran ais ou  trangers, des laboratoires publics ou priv es.

Heuristic for the preemptive asymmetric stacker crane problem

**H. L. M. Kerivin¹, M. Lacroix², A. Quilliot²,
H. Toussaint²**

Research Report LIMOS/ RR-09-01

9 février 2009

¹ *Department of Mathematical Sciences, Clemson University, CLEMSON, O-326 Martin Hall, Clemson, SC 29634 – USA*

² *LIMOS, CNRS UMR 6158, Université Blaise-Pascal - Clermont-Ferrand II, Complexe Scientifique des Cézeaux, 63177 Aubière, Cedex – France*

Heuristic for the preemptive asymmetric stacker crane problem

H. L. M. Kerivin ^a, M. Lacroix ^{b*}, A. Quilliot ^b, H. Toussaint ^b

^aDepartment of Mathematical Sciences, Clemson University, CLEMSON, O-326
Martin Hall, Clemson, SC 29634 - USA

^bLIMOS, CNRS UMR 6158, Université Blaise-Pascal - Clermont-Ferrand II,
Complexe Scientifique des Cèzeaux, 63177 Aubière, Cedex – France

* Corresponding author

Abstract

In this paper, we deal with the *preemptive asymmetric stacker crane* problem in an heuristic way. We first present some theoretical results which allow us to turn this problem into a specific tree design problem. We next derive from this new representation a simple, efficient local search heuristic, as well as an original LIP model. We conclude by presenting experimental results which aim at both testing the efficiency of our heuristic and at evaluating the impact of the preemption hypothesis

Keywords: preemptive asymmetric stacker crane problem, reloads, routing, local search, heuristic design.

1 Introduction

Pickup and delivery problems, which consist in scheduling the transportation of sets of goods/passengers from origin nodes to destination nodes while using a given set of vehicles, have been intensively studied for decades from both theoretical and practical points of view. Many variants have been considered and a lot of methods have been designed in order to improve the resolution of such problems. (One can refer to [7, 34, 40] for surveys on these problems and methods.) Among all the pick-up-and-delivery like problems which have been addressed by searchers, the *Stacker Crane Problem* is characterized by the fact that only one vehicle is involved, which can deal with only one demand unit at the same time. In this paper, we give a heuristic to handle what we call the *Preemptive Stacker Crane Problem*, that means the case when some demands can be dropped anywhere in the network and reloaded afterwards in order to gain time.

A rough description of the *Stacker Crane Problem (SCP)* can come as follows: G being some transit network whose oriented links or arcs are endowed with lengths or costs and which is provided with some specific *Depot* node, we are required to schedule the route of a single vehicle V , which is required to address a *Demand* set K , each demand $k \in K$ being defined by some origin node $o(k)$ and by some destination node $d(k)$. Namely, addressing the demand k means transporting some unique load unit $L(k)$ from $o(k)$ to $d(k)$ while using the vehicle V , whose capacity is such that it cannot contain more than one load unit $L(k)$, $k \in K$, at a given time. Thus, scheduling V means designing a route Γ inside the network G , which is going to start and end in *Depot* and to make possible for V to handle every demand k in K , and solving the *Stacker Crane Problem* will mean computing this route in such a way that this route is the shortest possible. Two versions of the **SCP** may be distinguished. In the first one, called *non-preemptive Stacker Crane Problem (NPSCP)*, every demand has to be directly carried from its origin to its destination. In the second version, which is called *Preemptive Stacker Crane Problem (PSCP)*, any load unit $L(k)$ related to demand k may be dropped (unloaded) at any node x of the transit network G , before being reloaded a little further and this unload/reload

process, which we call reload process, may be performed several times before the load unit $L(k)$ reaches the destination node $d(k)$. In case the cost or length function, which to any arc (x, y) , make correspond some length $DIST(x, y)$, is symmetric, we talk about Symmetric **SCP** (symmetric NPSCP or symmetric PSCP), and in the case the converse is true, we talk about asymmetric **SCP** (asymmetric NPSCP or asymmetric PSCP).

The *Stacker Crane* problem was first introduced by Frederickson et al. in [19], under its non preemptive symmetric form. They proved its NP-hardness by using a reduction from the TSP. They also got a $9/5$ -approximation scheme for this problem. Moreover, they proposed a natural extension of this problem to n identical vehicles, and obtained for this extension a $(1+\alpha-1/k)$ -approximation scheme, where α corresponds to the bound of the approximation for the problem with only one vehicle.

Atallah and Kosaraju [5] were the first to consider the preemptive version of the symmetric **SCP**. They studied both non-preemptive and preemptive versions of the symmetric **SCP** in the case when the underlying graph is an elementary path or an elementary cycle. They proved that in such a case, both versions are polynomial-time solvable. Frederickson and Guan [17, 18] studied both preemptive and non-preemptive versions of the symmetric **SCP** in the case when the underlying graph is a tree. They proved that the preemptive version is polynomial-time solvable and yielded two exact algorithms. However, the non-preemptive version was shown to be NP-hard and several α -approximations were provided.

Kerivin et al. [26] first proved that the optimal solutions of the preemptive stacker crane problem can be determined by the simple knowledge of the arc sets related to the vehicle route and to the demand paths. Using this result, they introduced, to the best of our knowledge, the first integer linear model for both symmetric and asymmetric versions of the preemptive **SCP** [25]. This formulation has a polynomial number of variables and an exponential number of constraints. However, the authors showed that the linear relaxation of the formulation can be solved in polynomial time.

Several variants of the pickup and delivery problems closely related to the **SCP** have been also studied. We should mention the *Pickup and Delivery Traveling Salesman Problem* (PDTSP) which corresponds to the non-preemptive stacker crane problem where no capacity constraint is taken into account (the vehicle V can contain as many object as required) and where every node of the network G is the origin or the destination of exactly one demand. Rodin and Ruland [39] presented an integer linear formulation for the PDTSP and used a branch-and-cut algorithm to solve it exactly. A polyhedral study of this formulation and of several other valid constraints was then made by Dumitrescu in [14]. The PDTSP has also been well studied from a heuristic point of view and many local search algorithms [22, 36, 37, 38] have been tested on the PDTSP, which involved a local transformation procedure defined as extensions of the k -interchange procedure defined by Lin [27] and Lin et Kernighan [28] for the TSP. The asymmetric version of the PDTSP was considered by Kalantari et al. [24] who developed a branch-and-bound algorithm based on Little et al. scheme for the asymmetric TSP [29]. Furthermore, if every node may be incident several demands while the vehicle route is imposed to define a Hamiltonian circuit, one can check that the asymmetric PDTSP is nothing but the Precedence Constrained Asymmetric TSP (PCATSP) also called the Sequential Ordering Problem (SOP). Polyhedral approaches and branch-and-cut algorithms [3, 4, 6, 21] as well as heuristics [10, 20, 32] have been devised to solve this problem.

Variants of the pickup and delivery problem with a single vehicle and capacity constraints have also been considered. For instance, Hernández-Pérez and Salazar-González [23] considered the SOP with capacity constraints, which they called the multi-commodity one-to-one pickup-and-delivery Traveling Salesman Problem (m-PDTSP). They gave mixed-integer linear formulations which they solved through branch-and-cut algorithms. Furthermore, the method given by Kalantari et al. in [24] may also be applied for the asymmetric PDTSP with capacity constraints. Kerivin et al. [25] extended their model for the preemptive asymmetric stacker crane problem when the vehicle (respectively demands) has a capacity (respectively volume).

Some of the previously mentioned problems have also been studied with additional constraints such as time windows [30, 34, 40], precedence constraints imposed to demand processes [15, 16] or LIFO loading policy [11]. Moreover, when the transportation involve human beings, the objective may not only to minimize the total cost of the vehicle route but may also put at stake people dissatisfaction [12,35] (which can be expressed using people riding time or difference between desired time and arrival one).

The stacker crane problem can be extended to the case where every demand has several origins and destinations. This extension, named the *Swapping Problem*, belongs to the class of *many-to-many* pickup and delivery problems (See [7] for a classification of routing problems). Usually, symmetric costs are considered. Moreover, it is assumed that every node is the origin of one demand and the destination of another one (a null demand may be considered if necessary). Swapping problems may be preemptive, non-preemptive, symmetric or non symmetric. They were first introduced by Anily and Hassin [2], which exhibited a 2.5-approximation scheme for some mixed version of the problem. Anily et al. [1] also considered the preemptive swapping problem in the case when the network is a tree. They proved that the problem remains NP-hard and gave in this case a 1.5-approximation. Recently, Bordenave et al. [8] presented a branch-and-cut algorithm for the preemptive swapping problem which allowed them to deal with instances with 100 nodes and 8 demands. They also designed a two-phase heuristic [9] for the asymmetric mixed swapping problem and applied to instances with up to 10000 nodes with an average optimality gap which did not exceed 1%.

Though many variants of single-vehicle pickup and delivery problems have been studied, we still may notice that few of them take into account the possibility of reloads in the transportation of the demands. In fact, what is more often considered is the case when reloads correspond to transshipments, that is, when a demand is unloaded from a vehicle in order to be reloaded into another vehicle. Such possibility may appear to pickup and delivery problems involving several vehicles. Despite the fact that these problems are quite different from the **SCP**, one must mention some of them in order to complete our bibliographic overview: Pickup and Delivery Problem with Transfers (PDPT) [13], the Pickup and Delivery Problem with Time-Windows and Transshipments (PDPTWT) [31] and the Pickup and Delivery Problem with Reloads (RPDP) [33]. When dealing with these problems, which sometimes involve account time-windows and capacity constraints, authors often prefer the terms transfer or transshipment to the words reloads or preemption.

Mitrovic-Minic and Laporte [31] gave a two-phase heuristic to approximately solve the PDPTWT. They first construct an initial solution using multi-start cheapest insertion procedure, and next improve this solution by successively removing and reinserting every demand, with one or no reload. The experimental results they obtained show that allowing transshipment may be very useful to reduce total travel distance.

In order to get a model for the RPDP, Oertel [33] defined an auxiliary graph by considering two copies of every origin/destination node. Using this new graph, he first proposed a mixed-integer formulation for the problem, and next designed a tabu search insertion based algorithm, which could efficiently deal with instances with more that seventy demands. Cortés et al. [13] used the same kind of trick and handled their model Benders decomposition.

The focus of this paper will be on the *preemptive asymmetric stacker crane* problem, which we shall denote by **APSCP**. We are first going (Section II) by setting our problem in a formal way, while assuming the triangle inequality for the cost function and while doing in such a way that origin/destination pairs of nodes become pairwise disjoint, that network be complete and that the asymmetric costs satisfy the triangle inequalities. Next (Section III) we shall prove some structural results which will allow us to turn our problem into a non constrained tree design problem. Thus reformulation of the problem will lead us to design (Section IV) in a natural way local search heuristic scheme together with a linear integer programming model, which will be implemented and tested in Section V, providing us with rather satisfactory numerical results.

II. A Formal Description of the APSC Problem.

Notations.

For any sequence $\Gamma = \{x_1, \dots, x_n\}$ and any object $x = x_i$ in Γ , we denote by $\text{Succ}(\Gamma, x)$ ($\text{Pred}(\Gamma, x)$), the successor (predecessor) x_{i+1} (x_{i-1}) of x in Γ , and by $\text{Rank}(\Gamma, x)$ the rank i of $x = x_i$ in Γ . A sequence with only one element x is denoted by $\{x\}$ and the empty sequence is denoted by Nil . We call subsequence of Γ any sequence Γ' which may be written $\{x_{i_1}, \dots, x_{i_p}\}$ with $i_1 < i_2 < \dots < i_p$.

The first (last) element x_1 (x_n) of Γ is denoted by $\text{First}(\Gamma)$ ($\text{Last}(\Gamma)$). The number n of element of Γ is denoted by $\text{Length}(\Gamma)$. We denote by \oplus the concatenation of operator, which takes two sequences $\Gamma = \{x_1, \dots, x_n\}$ and $\Gamma' = \{y_1, \dots, y_m\}$ and concatenates them into a unique sequence $\Gamma \oplus \Gamma' = \{x_1, \dots, x_n, y_1, \dots, y_m\}$. We denote by $*$ the operator which construct a sequence Γ from its first element x_1 and from its tail subsequence $\text{Tail}(\Gamma) = \{x_2, \dots, x_n\}$: $\Gamma = \text{First}(\Gamma) * \text{Tail}(\Gamma) = \{x_1, \dots, x_n\}$.

If $x = x_i$ and $y = x_j$ are two elements of Γ such that $i = \text{Rank}(\Gamma, x) \leq j = \text{Rank}(\Gamma, y)$, then we denote by $I(\Gamma, x, y)$ the subsequence $\{x_i, \dots, x_j\}$ of Γ , which is defined by all z such that $\text{Rank}(\Gamma, x) \leq \text{Rank}(\Gamma, z) \leq \text{Rank}(\Gamma, y)$. Any subsequence Γ' of Γ which may be written $I(\Gamma, x, y)$ is also called a *segment* of Γ . We call *cut* of Γ any decomposition $c = (\Gamma', \Gamma'')$ of Γ as a concatenation $\Gamma' \oplus \Gamma''$ where both Γ' and Γ'' are segments of Γ .

Modelling the Asymmetric Pre-emptive Stacker Crane Problem (APSCP);

As it was told in the introduction, the *Asymmetric Pre-emptive Stacker Crane Problem* can be roughly described as follows:

- a single vehicle V is required in order to address a set K of transportation demands, while performing some tour inside a given transit network G . Any demand $k \in K$ is expressed as a pair $(o(k), d(k))$ of nodes of G , according to the following semantics:
 - $o(k)$ is the origin node of k ; $d(k)$ is the destination node of k ;
 - V must transport exactly one load unit $L(k)$ from $o(k)$ to $d(k)$.
- the load capacity of V is equal to 1;
- V is allowed to address the demands of K in a pre-emptive way: it may, while carrying the load $L(k)$, stop at some node x , unload $L(k)$, deal with other demands and next come back to x , load again $L(k)$, and keep on with the handling of demand k . Such an intermediate load is then called a *reload node* for the demand k .
- V starts and ends its tour in a “*Depot*” node, and try to do it as fast as possible, in the sense of a cost (length) function which is supposed to be defined on the arcs of the network G .

In order to set a formal model for this problem, we make copies of the original nodes of the network G in such a way that the nodes *Depot*, $o(k)$, $d(k)$, $k \in K$, and the eventual reload nodes becomes all distinct. That means that we consider a node set X which may be written according to the following partition:

$$X = \{\text{Depot}\} \cup X_O \cup X_D \cup X_R$$

in such a way that:

$$X_O = \{o(k), k \in K\}; X_D = \{d(k), k \in K\};$$

X_R contains a copy of every element in $\{\text{Depot}\} \cup X_O \cup X_D$ together with a set of other eventual reload nodes.

Then the original cost (length) function which was defined on the arc set of the network G gives rise, through a shortest path computing process, to a $X.X$ indexed (*shortest path*) distance matrix DIST , such that if x is in $\{\text{Depot}\} \cup X_O \cup X_D$ and if x' is the copy of x in X_R then $\text{DIST}(x, x') = 0$. We suppose of course that DIST satisfies the **Triangle Inequality Property**, but that it does not need to be symmetric.

Then we define *labelled link* (L.L), as being any triple $r = (x, y, k)$, where x and y are nodes of X and k is a label in the set $\{0\} \cup K$: x (y) is called the *starting node* (*ending node*) of the labelled link r and is denoted by $\text{Start}(r)$ ($\text{End}(r)$); k is called the *label* of r and is denoted by $\text{Label}(r)$.

It comes that a *tour* defined on X is going to be a sequence Γ of labelled links. For such a tour Γ , and for any label k in $\{0\} \cup K$, we denote by $\Gamma(k)$ the labelled link sequence which derives in a natural way from Γ by only considering the labelled link r such that $\text{Label}(r) = k$, and we call it the *deriving subsequence* of G related to the label k . Of course, we understand that the meaning of the label $k = \text{Label}(r)$ of some labelled link which appears in a tour G related to the activity of the vehicle V , is that $k = 0$ means that V is empty when running from $x = \text{Start}(r)$ to $y = \text{End}(r)$ and that $k \neq 0$ means that V is then carrying the unit load $L(k)$.

The cost of Γ is then defined in a natural way as the quantity:

$$\text{Cost}(\Gamma) = \sum_{r \in \Gamma} \text{DIST}(\text{Start}(r), \text{End}(r)).$$

Clearly, not any tour Γ may be viewed as reflecting the activity of a vehicle V which conveniently handles every demand $k \in K$. We see that in order to get it, we need to impose G to be *valid*, which will mean that:

- for any consecutive pair of labelled links $r, r' = \text{Succ}(G, r)$ in G , we have $\text{End}(r) = \text{Start}(r')$;
- $\text{Start}(\text{First}(\Gamma)) = \text{End}(\text{Last}(\Gamma)) = \text{Depot}$;
- Any node x in $X_O \cup X_D$ is involved in exactly two labelled links r and $r' = \text{Succ}(\Gamma, r)$: this means that V moves to $o(k)$ ($d(k)$), $k \in K$, only when it comes to start (finish) dealing with demand k ;
- The *Depot* node is involved only in both labelled links $r = \text{First}(\Gamma)$ and $r' = \text{Last}(\Gamma)$;
- For any demand $k \in K$, the deriving subsequence $\Gamma(k)$ related to k is such that:
 - $\text{Start}(\text{First}(\Gamma(k))) = o(k)$;
 - $\text{End}(\text{Last}(\Gamma(k))) = d(k)$;
 - For any consecutive labelled link pair $r, r' = \text{Succ}(\Gamma(k), r)$, we have $\text{End}(r) = \text{Start}(r')$.

The following figure 1 provides us with a visualization of a valid tour $\Gamma = \{(\text{Depot}, o_1, 0), (o_1, x, 1), (x, o_2, 0), (o_2, y, 2), (y, o_3, 0), (o_3, x, 3), (x, d_1, 1), (d_1, y, 0), (y, d_2, 2), (d_2, 0, x), (x, d_3, 3), (d_3, \text{Depot}, 0)\}$.

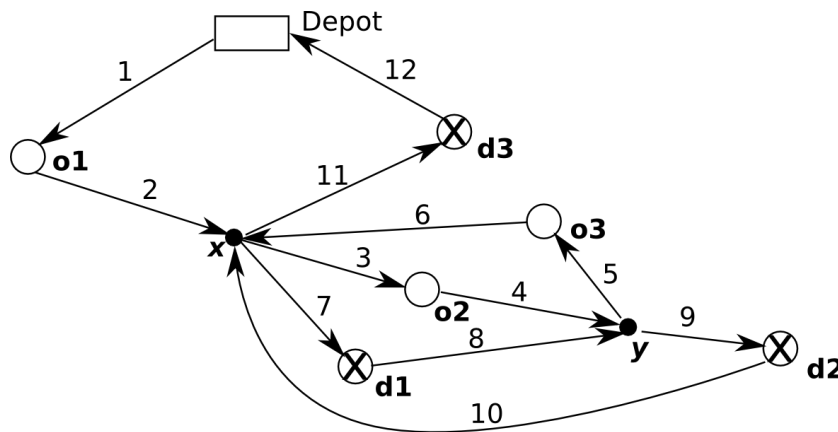

Figure 1: Visualizing a valid tour Γ .

All these definitions allow us to formally set our **APSCP** (*Asymmetric Pre-emptive Stacker Crane Problem*) Problem as follows:

APSCP Problem:

{Given the node set X and the Shortest Path Distance Matrix $DIST$, compute a valid tour Γ with minimal cost}.

III. Some Structural Results.

We are now going to state and prove some results which will be the basis for the design of the heuristics which will be described in Section IV.

III. 1. A Theorem.

Let Γ some valid tour. For any labelled link $r = (x, o(k), 0)$ in Γ , we denote by $\sigma(\Gamma, r)$ the unique labelled link $(d(k), y, 0)$ which is also in Γ . By the same way, if x is some node in X_R , such that a triple a labelled link $r = (y, x, k)$, $k \geq 1$, is in Γ , then we also denote by $\sigma(\Gamma, r)$ the unique triple $r' = (x, z, k)$ which exists in G and which is such that:

- $\text{Rank}(\Gamma, r') > \text{Rank}(\Gamma, r)$;
- $\text{Rank}(\Gamma, r')$ is minimal with this property.

We say that two Labelled links r and r' in Γ are *overlapping* if we have:

$$\text{Rank}(\Gamma, \sigma(\Gamma, r')) > \text{Rank}(\Gamma, \sigma(\Gamma, r)) > \text{Rank}(\Gamma, r') > \text{Rank}(\Gamma, r).$$

Then we may state:

Theorem 1.

Let Γ be some optimal tour for the **APSCP** Problem, which we suppose chosen in such a way that:

- (A): $\text{Length}(\Gamma)$ is the smallest possible;
- (B): the number of labelled links r in Γ which are such that $\text{Label}(r) \neq 0$ is the smallest possible, (A) being supposed to be satisfied;

Then, the following assertions must be true:

- (S1): Γ does not contain two occurrences of the same labelled link $r = (x, y, k)$, with $k \neq 0$;
- (S2): Γ does not contain two consecutive labelled links r and r' such that $\text{Label}(r) = \text{Label}(r')$;
- (S3): Γ does not contain two overlapping labelled links r and r' ;
- (S4): Γ does not contain two labelled links r and r' such that $\text{End}(r) = \text{End}(r')$.

Proof.

We assume that Γ is given, which is an optimal solution of **APSCP** and which is such that (A) and (B) are true.

Part (S1).

If $r = (x, y, k)$, $k > 0$ appears twice in Γ , with respectively rank s and s' , then x and y are both reload nodes, and we may replace, in any labelled link r'' which is such that:

- $s \leq \text{Rank}(\Gamma, r'') < s'$;
- $\text{Label}(r'') = k$;

the label value $\text{Label}(r'')$ by 0. While doing it, we keep on with a valid tour which is an optimal solution of **APSCP** and we get a contradiction on the (B) hypothesis.

Part (S2).

If $r = (x, y, k)$ and $r' = (y, z, k)$ were two consecutive labelled links of Γ such that $\text{Label}(r) = \text{Label}(r')$, then we would be able to remove both r and r' from Γ , and replace them by a unique labelled link (x, z, k) . While doing this, we would also keep, because of the Triangle property on the $DIST$ matrix, an optimal solution of **APSCP**, and this solution would contradict the (A) hypothesis.

Part (S3).

Let us suppose that there exists two labelled links $r = (y, x, k)$ and $r' = (y', x', k')$ which are overlapping in Γ . We may choose them in such a way that $\text{Rank}(\Gamma, \sigma(\Gamma, r')) - \text{Rank}(\Gamma, r)$ is the smallest possible. (E1)

Because of (E1), we see that x and x' must be reload nodes: if, for instance, x were an origin node $o(h)$, then we would have $k' \neq h$ and there would exist an labelled link r'' such that:

- $\text{Label}(r'') = h$;
- $\text{Rank}(G, r) < \text{Rank}(G, r'') < \text{Rank}(G, r') < \text{Rank}(G, \sigma(\Gamma, r'')) < \text{Rank}(G, \sigma(\Gamma, r)) < \text{Rank}(G, \sigma(\Gamma, r'))$.

Then we might deduce a new overlapping pair (r'', r') which would induce a contradiction on the minimality assumption (E1). By the same way, we may check that x' cannot be an origin node $o(h)$. Thus x and x' are both reloads nodes, and we clearly have: $k \neq k' \neq 0$.

It comes that we may write:

- $r = (y, x, k), r' = (y', x', k')$;
- $\sigma(\Gamma, r) = (x, z, k), \sigma(\Gamma, r') = (x', z', k')$.

So, we set :

- $\Gamma_1 = I(\Gamma, \text{First}(\Gamma), r)$;
- $\Gamma_2 = I(\Gamma, \text{Succ}(\Gamma, r), r')$;
- $\Gamma_3 = I(\Gamma, \text{Succ}(\Gamma, r'), \text{Pred}(\Gamma, \sigma(\Gamma, r)))$;
- $\Gamma_4 = I(\Gamma, \sigma(\Gamma, r), \text{Pred}(\Gamma, \sigma(\Gamma, r')))$;
- $\Gamma_5 = I(\Gamma, \sigma(\Gamma, r'), \text{Last}(\Gamma))$,a

and we replace Γ by the concatenation $\Gamma_{\text{Aux}} = \Gamma_1 \oplus \Gamma_4 \oplus \Gamma_3 \oplus \Gamma_2 \oplus \Gamma_5$. Of course, the lengths of Γ and are Γ_{Aux} equal, as well as their respective costs. So we state:

Lemma 1.

Γ_{Aux} defined above is a valid tour.

Proof-Lemma.

We only need to check that switching Γ_2, Γ_3 and Γ_4 does not break any sequence $\Gamma(k)$, or, in other words, that for any $k \neq 0$, we have $\Gamma(k) = \Gamma_{\text{Aux}}(k)$. If the converse were true, we would be able to find $k'' \neq k', k, k'' \neq 0$, as well as two labelled links r'' and $\sigma(\Gamma, r'')$, with label k'' or with the ending node of r'' equal to $o(k'')$, such that one of the three following relations would be true:

$$- r'' \in \Gamma_2 \text{ and } \sigma(\Gamma, r'') \in \Gamma_3; \quad (\text{E2});$$

$$- r'' \in \Gamma_2 \text{ and } \sigma(\Gamma, r'') \in \Gamma_4; \quad (\text{E3});$$

$$- r'' \in \Gamma_3 \text{ and } \sigma(\Gamma, r'') \in \Gamma_4; \quad (\text{E4});$$

In case (E2) or (E3) were true, r'' and r' would be overlapping, and would contradict the (E1) hypothesis, related to the minimality of $\text{Rank}(\Gamma, \sigma(\Gamma, r')) - \text{Rank}(\Gamma, r)$

In case (E4) were true, r and r'' would be overlapping, and would contradict the (E1) hypothesis, related to the minimality of $\text{Rank}(\Gamma, \sigma(\Gamma, r')) - \text{Rank}(\Gamma, r)$.

In any case, we become able to conclude. END-LEMMA.

The above lemma allows us to conclude the proof of (S3) by noticing that r and $\sigma(\Gamma, r)$ become consecutive in the valid tour Γ_{Aux} , which implies (proof of statement (S2)) that r and $\sigma(\Gamma, r)$ may be replaced in Γ_{Aux} by a unique labelled link (y, z, k) in such a way that $\text{Cost}(\Gamma_{\text{Aux}})$ does not increase and that $\text{Length}(\Gamma_{\text{Aux}})$ decreases, inducing a contradiction on the (A) hypothesis.

Part (S4).

Let us suppose that Γ contains two labelled links r and r' such that $\text{End}(r) = \text{End}(r')$ and such that $\text{Rank}(\Gamma, r) < \text{Rank}(\Gamma, r')$. Since the starting node x of r cannot be in $\{\text{Depot}\} \cup X_D$, it must be a reload node in X_R which is used twice as a reload node. So, $r, \sigma(\Gamma, r)$ and r' and $\sigma(\Gamma, r')$ may be written:

- $r = (y, x, k), k \neq 0$;
- $r' = (y', x, k'), k' \neq 0, k$;
- $\sigma(\Gamma, r) = (x, z, k)$;

- $\sigma(\Gamma, r') = (x, z', k')$.

Because of (S3) we must have:

$$\text{Rank}(\Gamma, r) < \text{Rank}(\Gamma, \sigma(\Gamma, r)) < \text{Rank}(\Gamma, r') < \text{Rank}(\Gamma, \sigma(\Gamma, r')) \quad (\text{E5})$$

or

$$\text{Rank}(\Gamma, r) < \text{Rank}(\Gamma, r') < \text{Rank}(\Gamma, \sigma(\Gamma, r')) < \text{Rank}(\Gamma, \sigma(\Gamma, r)). \quad (\text{E6})$$

Let us first suppose that (E5) holds. Then we set:

- $\Gamma_1 = I(\Gamma, \text{First}(\Gamma), r)$;
- $\Gamma_2 = I(\Gamma, \text{Succ}(\Gamma, r), \text{Pred}(\Gamma, \sigma(\Gamma, r)))$;
- $\Gamma_3 = I(\Gamma, \sigma(\Gamma, r), r')$;
- $\Gamma_4 = I(\Gamma, \text{Succ}(\Gamma, r'), \text{Pred}(\Gamma, \sigma(\Gamma, r')))$;
- $\Gamma_5 = I(\Gamma, \sigma(\Gamma, r'), \text{Last}(\Gamma))$,

and we replace Γ by the concatenation $\Gamma_{\text{Aux}} = \Gamma_1 \oplus \Gamma_3 \oplus \Gamma_2 \oplus \Gamma_4 \oplus \Gamma_5$. Of course, the lengths of Γ and Γ_{Aux} are equal, as well as their respective costs, and we proceed as in the proof of (S3) in order to prove that Γ_{Aux} must be a valid tour. But we also notice, as in the proof of (S3), that Γ_{Aux} can be shortened by replacing the consecutive labelled links r and r^* by a unique labelled link (y, z, k) , in such a way that $\text{Cost}(\Gamma_{\text{Aux}})$ does not increase and that $\text{Length}(\Gamma_{\text{Aux}})$ decreases, inducing a contradiction on the (A) hypothesis.

We apply exactly the same kind of reasoning in case (E6) holds. END-THEOREM.

III. 2. A Tree Representation of the APSCP Problem.

Theorem 1 leads us to introduce the following definition:

Strongly Valid Tour: a valid tour Γ is a *strongly valid* tour if it satisfies the (S1)...(S4) properties which are listed into the statement of Theorem 1.

The following figure 2 shows us how the valid tour Γ of Figure 1 may be turned into a strongly valid tour whose cost Γ' is no more than the cost of Γ :

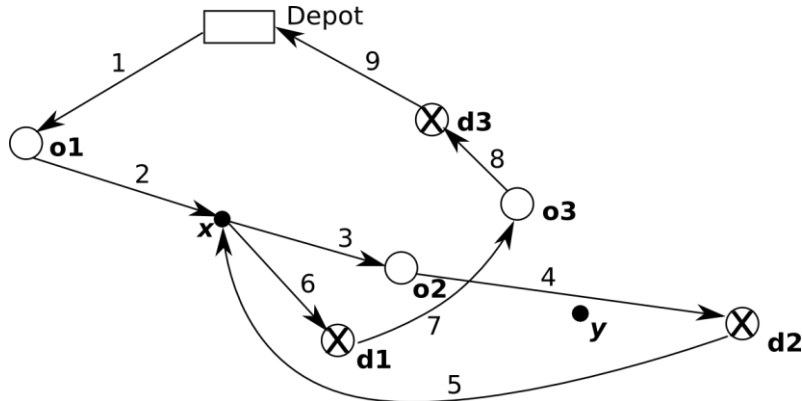

Figure 2: A derivation of the valid tour Γ of figure 1 into a strongly valid tour Γ' .

Clearly, solving the APSCP Problem means finding a strongly valid tour Γ with minimal cost value.

Now, we are going to see that any strongly valid tour may be represented as some kind of tree, and this will provide us with the basis (section IV) for the algorithms which we are going to design in order to deal with APSCP.

Bipartite Ordered Trees: we say that a tree T is a *bipartite ordered tree* if:

- its nodes can be split into two classes A and B in such way that nodes in class A have their sons in class B and conversely;

- for every node x in T which is not a terminal node (leaf) the son set $\phi(T, x)$ associated with x is linearly ordered: thus $\phi(T, x)$ is described as a sequence.

We say that a bipartite ordered tree T is *consistent* from the **APSCP** instance defined by the demand set K and by the node set X if:

- the nodes in T can be identified with the demands $k \in K$ (we shall then talk about *demand* nodes) or with nodes in $\{Depot\} \cup X_R$, (and then we talk about *reload* nodes) and any possible demand node $k \in K$ appears in T , while only some of nodes of $\{Depot\} \cup X_R$ appear in T : those nodes in $\{Depot\} \cup X_R$ define the *active* reload node set $ACTIVE(T)$ of T ; (S5)
- The root of T is the *Depot* node and the terminal nodes (leaves) of T must belong to the demand node set; (S6)
- For any demand node k , its linearly ordered *son* set $RELOAD(T, k)$ in T is made with active reload nodes and its father $FATHER(T, k)$ is in $ACTIVE(T)$; (S7)
- For any reload node x , its linearly ordered *son* set $DEMAND(T, x)$ in T is made with demand nodes and its father $FATHER(T, x)$ is in K . (S8)

For such a bipartite ordered tree T , we may define a cost value *Tree-Cost* as follows:

- for any demand node $k \in K$: we set:
If k is not a terminal node then

$$\begin{aligned} \text{Cost-Demand}(T, k) = & \text{DIST}(o(k), \text{First}(\text{Reload}(T, k))) \\ & + \text{DIST}(\text{Last}(\text{Reload}(T, k)), d(k)) \\ & + \sum_{x \in \text{Reload}(T, k), x \neq \text{Last}(\text{Reload}(T, k))} \text{DIST}(x, \text{Succ}(\text{Reload}(T, k), x)) \end{aligned}$$
else $\text{Cost-Demand}(T, k) = \text{DIST}(o(k), d(k))$
- for any reload node $x \in \{Depot\} \cup X_R$, we set:

$$\begin{aligned} \text{Cost-Reload}(T, k) = & \text{DIST}(x, o(\text{First}(\text{Demand}(T, x)))) + \text{DIST}(d(\text{Last}(\text{Demand}(T, x))), x) \\ & + \sum_{k \in \text{Demand}(T, x), k \neq \text{Last}(\text{Demand}(T, x))} \text{DIST}(d(k), o(\text{Succ}(\text{Reload}(T, x), k))); \end{aligned}$$
- $\text{Tree-Cost}(T) = \text{Cost}(\Gamma) = \sum_{k \in K} \text{Cost-Demand}(T, k) + \sum_{x \in ACTIVE(T)} \text{Cost-Reload}(T, x)$.

Theorem 2: There is a one-to-one correspondence *Tree* between the strongly valid tours and the bipartite ordered tour which are consistent with X and K , which is such that, for any strongly valid tour Γ , we have: $\text{Tree-Cost}(\text{Tree}(\Gamma)) = \text{Cost}(\Gamma)$.

Proof.

We first consider a strongly valid tour Γ and perform the following construction, which make us get $\text{Tree}(\Gamma)$ from Γ :

- $ACTIVE(T(\Gamma))$ is defined as the set of the nodes of $\{Depot\} \cup X_R$ which appear in some labelled link of Γ , and which are then said to be *active reload* nodes for Γ ;
- For any demand node $k \in K$, the son set $\text{Reload}(T(\Gamma), k)$ is made with the reload nodes which appear in some labelled link of $\Gamma(k)$, ordered according to their appearance order in $\Gamma(k)$;
- For any active reload node x in $\{Depot\} \cup X_R$, we denote by $\rho(x) = (x, y, 0)$ and by $\tau(x) = (z, x, 0)$ the two labelled links with label 0 which involve x in Γ and which are such that: $\text{Rank}(\Gamma, \rho(x)) < \text{Rank}(\Gamma, \tau(x))$. Then we define the son set $\text{Demand}(T(\Gamma), x)$ by setting that a demand $k \in K$ is a son of x if the unique labelled link $r(k) = (o(k), t, k)$ which appears in Γ is such that:
 - $\text{Rank}(\Gamma, \rho(x)) < \text{Rank}(\Gamma, r(k)) < \text{Rank}(\Gamma, \tau(x))$
 - there exists no reload node y such that $\text{Rank}(\Gamma, \rho(x)) < \text{Rank}(\Gamma, \rho(y)) < \text{Rank}(\Gamma, r(k)) < \text{Rank}(\Gamma, \tau(y)) < \text{Rank}(\Gamma, \tau(x))$.

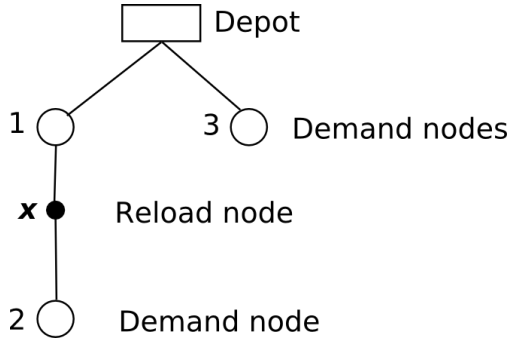

Figure 3: The bipartite tree $Tree(\Gamma')$ which derives from the strongly valid tour Γ' of Figure 2.

Then it comes next that checking that the so defined *Tree* correspondence is as it is claimed in the statement of Theorem 2 is purely routine. END-THEOREM.

We deduce:

Corollary 1: Solving a **APSCP** instance $(X, DIST, K)$ means finding a bipartite ordered tree T consistent with $(X$ and $K)$ such that $Tree-Cost(T)$ is the smallest possible.

The interest of this last statement is clearly that it provides us with a bipartite tree formulation of the **APSCP** problem which is far less constrained than the original one.

III.3. A related Integer Linear Programming formulation of APSCP.

This ILP formulation is going to allow us to compare, in the case of small instances, the results obtained through the heuristic methods which will be described in Section IV with exact results. In order to get it, we first need to proceed to the following construction:

- **An auxiliary network $G = (X^*, E)$.**

We first consider a copy X^*_R of the reload node set X_R and a copy $Depot^*$ of the *Depot* node, and we set: $X^* = X \cup X^*_R \cup \{Depot^*\}$;

For any node x in X_R , we denote by x^* its copy in X^*_R . Also, for any origin node $x = o(k)$ in X_O , we denote by x^* the related node $d(k)$.

Then we define, on the node set X^* , the arc set E as follows:

- $E = \{(Depot, x), x \in X_O\} \cup \{(x, Depot^*), x \in X_D\} \cup \{(o(k), d(k)), k \in K\}$
 $\cup \{(d(k'), o(k)), k \neq k' \in K\}$
 $\cup \{(x, y), (y, x), x \in X_O, y \in X_R\} \cup \{(x, y), (y, x), x \in X^*_R, y \in X_D\}$
 $\cup \{(x, y), x \in X^*_R, y \in X_R\}$.

- every arc e in E is then provided with a length $DIST^*(e)$ which derives from the $DIST$ distance matrix in a natural way.

Let us recall that a path γ of a such a network G is a node sequence γ such that, for any node x in γ , the pair $(x, Succ(\gamma, x))$ defines an arc of E . One easily checks that any strongly valid tour Γ can be turned into a path Γ^* of the network G , in such a way that:

- (S9): Γ^* starts from *Depot* and ends into *Depot^** and Γ^* is an elementary path, i.e, its visits any node at most once;
- (S10): for every k in K , Γ^* visits $o(k)$ and $d(k)$, according to this order and for every x in X_R , Γ^* visits x if and only if it visits x^* , and, in case it does it, it does it according to this order;
- (S11): for any pair $x, y, x \neq y$, in $X_R \cup X_O$ the following implication is true:

$$\text{Rank}(\Gamma^*, x) < \text{Rank}(\Gamma^*, y) \text{ and } \text{Rank}(\Gamma^*, y) < \text{Rank}(\Gamma^*, x^*) \\ \Rightarrow$$

$$\text{Rank}(\Gamma^*, y^*) < \text{Rank}(\Gamma^*, x^*).$$

This condition is called the *non overlapping condition*.

- (S12): $\text{Cost}(\Gamma) = \sum_{x \in \Gamma^*, x \neq \text{Depot}^*} \text{DIST}^*(x, \text{Succ}(\Gamma^*, x)) = \text{Length of } \Gamma^*$ for the DIST^* length function.

A path of the network G which satisfies (S9)...(S12) above will be said to be a *strongly valid path*.

Theorem 3.

For any strongly valid path γ , there exists a strongly valid tour Γ such that $\Gamma^* = \gamma$.

Proof.

Let us first describe in an accurate the way Γ is going to derives from γ . It will occur through the following **RECONSTRUCT** procedure:

RECONSTRUCT Procedure

$x \leftarrow \text{Depot}; \Gamma \leftarrow \text{Nil};$

While $x \triangleleft \text{Depot}^*$ **do**

$y \leftarrow \text{Succ}(\gamma, x);$

If y may be written $y = z^*$, with $z \in \{\text{Depot}\} \cup X_R$, **then** we set $\Pi(y) = z$,

else we set $\Pi(y) = y$;

If (multi-case branching instruction)

1. $x = \text{Depot}$ **then** $\Gamma \leftarrow (x, y, 0)^* \Gamma$;

2. $x = o(k)$, $k \in K$ **then** $\Gamma \leftarrow (x, y, k)^* \Gamma$;

3. $x \in X_R$ **then** $\Gamma \leftarrow (x, \Pi(y), 0)^* \Gamma$;

4. $x \in X_D$ **then** $\Gamma \leftarrow (x, \Pi(y), 0)^* \Gamma$;

5. $x \in X_R^*$ **then** $\Gamma \leftarrow (x, y, k)^* \Gamma$, where $k \neq 0$ is such that the labelled link $(\text{Pred}(\gamma, \Pi(x)), \Pi(x), k)$ is already in Γ ;

(I1)

The instruction (I1) works here because of (S10) above, and because an arc of G which arrives on $\Pi(x)$ must come from an origin node $o(k)$ or from a node z in X_R^* . In this last case, a simple induction reasoning makes appear the fact that k is different from 0.

We get our result while proceeding by induction on the length (the number of nodes) of γ . In case γ involves no node in X_R , then the results come in a trivial way. Else, we consider $x_0 \in X_R$ which is the first node of X_R which appears in γ . We notice that $\text{Pred}(\gamma, x_0)$ must be some node $o(k)$, $k \in K$. Thus the arc $(\text{Pred}(\gamma, x_0), \text{Succ}(\gamma, x_0^*))$ belongs to the arc set E , and the removal of the subpath $I(\gamma, x_0, x_0^*)$ from γ provides us with an other path γ_1 of the graph G . Let us set:

$K_1 = \{k \in K \text{ such that } o(k) \text{ and } d(k) \text{ are nodes of } \gamma_1\};$

$K_2 = \{k \in K \text{ such that } o(k) \text{ and } d(k) \text{ are nodes of } \gamma_2 = I(\gamma, x_0, x_0^*)\};$

K_1 and K_2 define a partition of K , and one sees that γ_2 can be viewed as a strongly valid path, if we restrict ourselves to K_2 as a demand set and if we consider that x_0 and x_0^* play the role of *Depot* and *Depot*^{*}. Thus it comes from the induction hypothesis that it may be written, under this restriction, according to the form $\gamma_2 = \Gamma_2^*$. By the same way, γ_1 is also a strongly valid path if we restrict the demand node set to K_1 , and it comes from the induction hypothesis that it may be written, under this restriction, according to the form $\gamma_1 = \Gamma_1^*$. We only need to insert Γ_2 between $\text{Pred}(\gamma, x_0)$, x_0, k and $(x_0, \text{Succ}(\gamma, x_0^*), k)$ in Γ_1 , in order to get Γ such that $\gamma = \Gamma^*$. END-THEOREM.

Corollary 2: Solving a **APSCP** instance (X, DIST, K) means finding a strongly valid path γ with minimal length (for the DIST^* length function) value in the network G .

This corollary allows us to set an Integer Linear Programming model as follows:

This model involves a $\{0, 1\}$ vector flow $z = (z_e, e \in E)$, a Rank integral vector $R = (R_x, x \in X)$, as well as a *positional* $\{0, 1\}$ vector t , which is indexed on the pairs (x, y) , $x \neq y$, $x, y \in X_R \cup X_O$, with the following semantics:

- for any arc e in E , $z_e = 1$ iff the arc e is in the strongly valid path γ ;

- for any node x in γ , R_x will provide us with the rank of x in γ ;
- for any pair (x, y) , $x \neq y$, $x, y \in X_R \cup X_O$:
 - $t_{x,y} = 1$ iff $\text{Rank}(\gamma, y) < \text{Rank}(\gamma, x^*)$;
 - $t_{x,y} = 0$ iff $\text{Rank}(\gamma, x^*) < \text{Rank}(\gamma, y)$;

Then the translation of (S9)...(S12) into Integer Linear Programming constraints provides us with the following linear integer program:

APSCP Integer Linear Programming Formulation.

Unknown vectors.

$z = (z_e, e \in E)$, with values in $\{0,1\}$; $R = (R_x, x \in X)$ Integral and ≥ 0 ;

$t = (t_{x,y}, x \neq y, x, y \in X_R \cup X_O)$ with values in $\{0,1\}$.

Performance Criterion.

Minimize $\sum_{e \in E} \text{DIST}^*(e) \cdot z_e$ (translation of (S12))

Constraints.

- z is a flow vector, which satisfies the usual Kirshoff law in any node but in *Depot* and *Depot**;
- the inflow induced by z in *Depot* (*Depot**) is equal to 0 (1), while the related outflow is equal to 1 (0); (translation of (S9))
- in any node of $X_D \cup X_O$, the inflow induced by z is equal to 1; (translation of (S10))
- in any node of $X_R \cup X^*_R$, the inflow induced by z is at most equal to 1, and the inflow value in x is equal to the inflow value in x^* ; (translation of (S10) and (S9))
- for any k in K , we have $R_{o(k)} \leq R_{d(k)} - 1$; (translation of (S10))
- for any x in X_R , we have $R_x \leq R_{x^*} - 1$; (translation of (S10))
- for any arc $e = (x,y)$ in E , we have $z_e + (R_x + 1 - R_y) / \text{Card}(X^*) \leq 1$; (translation of the implication $z_e = 1 \rightarrow (R_x + 1 - R_y) \leq 0$)
- for any pair (x, y) , $x \neq y$, $x, y \in X_R \cup X_O$: (translation of the non overlapping condition)
 - $t_{x,y} + (R_y + 1 - R_{x^*}) / \text{Card}(X^*) \leq 1$;
 - $t_{x,y} + (R_y - 1 - R_{x^*}) / \text{Card}(X^*) \geq 0$;
 - $t_{x,y} + (R_{y^*} + 1 - R_{x^*}) / \text{Card}(X^*) \leq 1$.

Corollary 2: Solving a **APSCP** instance (X, DIST, K) means solving the above Integer Linear Programming model.

IV. Tree Based Heuristics for the APSCP Problem.

The algorithms which we are going to describe here, and which will be tested in the next Section, derive in a straightforward way from the tree representation of the **APSCP** Problem which we got in Section III.2. These algorithms are very simple greedy insertion algorithms and descent algorithms, based upon the use of 2 classes of operators:

Insertion Operators: these operators act on some bipartite ordered tree T consistent with the node set X and with a subset K' of the demand set K , and *insert* some demand $k \in K - K'$ in T . We use two operators:

INSERT-SIMPLE: its parameters are some active reload node x in $\{\text{Depot}\} \cup X_R$, and some cut (l_1, l_2) of the sequence $\text{DEMANDE}(T, x) = l_1 \oplus l_2$. It acts by *inserting* the segment $\{k\}$ into this cut: $\text{DEMANDE}(T, x) \leftarrow l_1 \oplus \{k\} \oplus l_2$.

INSERT-with-RELOAD: its parameters are some demand node k' in K' , a cut $c = (l_1, l_2)$ of the sequence $\text{RELOAD}(T, k')$, and a non active reload node x . It acts by:

- inserting the segment $\{x\}$ into the cut c : $\text{RELOAD}(T, x) \leftarrow l_1 \oplus \{x\} \oplus l_2$;
- by making x be active and setting: $\text{DEMAND}(T, x) \leftarrow \{k\}$; $\text{RELOAD}(T, k) \leftarrow \text{Nil}$.

Local Transformation Operators: these operators act through side effect on some bipartite ordered tree T consistent with X and K , and they modify T . We use 6 operators:

- **MOVE-RELOAD:** its parameters are some active reload node x and some non active reload node y . It replaces x by y in T .
- **MOVE-RELOADS:** its parameters are two different demand nodes k and k' , a segment l of $\text{RELOAD}(T, k)$ and a cut $c = (l_1, l_2)$ of $\text{RELOAD}(T, k')$. It removes l from $\text{RELOAD}(T, k)$ and it inserts it into the cut c . Its precondition is that k does not *dominate* k' in the tree T , i.e., that k cannot be obtained from k' through a succession of applications of the FATHER operator.
- **MOVE-RELOADS1:** its parameters are some demand node k , some segment l of $\text{RELOAD}(T, k)$ which induces a decomposition $\text{RELOAD}(T, k) = l_3 \oplus l \oplus l_4$, and a cut $c = (l_1, l_2)$ of $l_3 \oplus l_4$. It first remove l and next insert it into the cut c : $\text{RELOAD}(T, k') \leftarrow l_1 \oplus l \oplus l_2$.
- **MOVE-DEMANDS:** its parameters are two different active reload nodes x and y , a segment l of $\text{DEMAND}(T, x)$, and a cut $c = (l_1, l_2)$ of $\text{DEMAND}(T, x')$. It removes l from $\text{DEMAND}(T, x)$ and it inserts it into the cut c . In case $l_1 = l_2 = \text{Nil}$, it remove the reload node x from T , which becomes non active. Its precondition is that x does not *dominate* y in the tree T .
- **MOVE-DEMAND1:** its parameters are some reload node x , some segment l of $\text{DEMAND}(T, x)$ which induces a decomposition $\text{DEMAND}(T, x) = l_3 \oplus l \oplus l_4$, and a cut $c = (l_1, l_2)$ of $l_3 \oplus l_4$. It first remove l and next insert it and it into the cut c : $\text{DEMAND}(T, x) \leftarrow l_1 \oplus l \oplus l_2$.
- **MOVE-DEMANDS-RELOAD:** its parameters are an active reload node x , a non active reload node y , a demand node k , a segment l of $\text{DEMAND}(T, x)$ and a cut $c = (l_1, l_2)$ of $\text{RELOAD}(T, k)$. It first turns y into an active reload node, next removes l from $\text{DEMAND}(T, x)$ and inserts it into $\text{DEMAND}(T, y)$, and ends in inserting the segment $\{y\}$ into the cut c . In case $l = \text{DEMAND}(T, x)$, it turns x into a non active reload node. Its precondition is that k is *dominated* by not demand node k' in l .

Then we can propose a first insertion greedy algorithm for dealing with **APSCP**:

Algorithm APS-INSERTION:

Randomly define a linear ordering ρ on the elements of K ;

$T = \{\text{the tree reduced to the root node } Depot\}$;

For $k \in K$, K being scanned according to the linear order ρ **do**

Compute the insertion operator I (among INSERT-SIMPLE and INSERT-with-RELOAD) and the related parameter u ($u = (x, (l_1, l_2))$ in case $I = \text{INSERT-SIMPLE}$, $u = (k', (l_1, l_2), x)$ in case $I = \text{INSERT-with-RELOAD}$), such that the insertion of k through $I(u)$ induces the smallest possible increase of $\text{Tree-Cost}(T)$;

Apply $I(u)$ to T ;

Filtering the search for the good value of the parameter u .

In case $I = \text{INSERT-SIMPLE}$, the related optimal value of u can be obtained in a very fast way through exhaustive scanning of the sequences $\text{DEMAND}(T, x)$ for all the active reload nodes x . In case $I = \text{INSERT-with-RELOAD}$, one must deal with the search for the new reload node x , which may be time consuming in case X_R is large. In order to avoid spending too much time while trying all the possible reload nodes x , we try to identify in a fast way those nodes which are likely to provide us with an efficient insertion by proceeding as follows:

- for every node x in X_R , we keep in memory a set $N(x)$ of *neighbours* of x , that means of nodes y which are such that $\text{DIST}(x, y) \leq R$, where R is some threshold which is chosen in such a way that the induced neighbour graph be connected, and that the cardinality of any set $N(x)$ remains small enough.

- by the same way, we keep in memory, for every pair of reload nodes (x, y) , what we call the middle of x and y , that means some node $z = \text{MID}(x, y)$ which is such that the difference between $\text{DIST}(x, z) + \text{DIST}(z, y) - \text{DIST}(x, y)$ remains small, both quantities $\text{DIST}(x, z)$ and $\text{DIST}(y, z)$ being close to each other;
- if we denote by y the last reload node in l_1 and by z the first reload node in l_2 , then we see that we should try to select x in such a way that $\text{DIST}(y, x) + \text{DIST}(x, o(k)) + \text{DIST}(d(k), x) + \text{DIST}(x, z)$ be the smallest possible. Instead of trying all the possible nodes of X_R we do it by selecting $t = \text{MID}(\text{MID}(y, o(k)), \text{MID}(d(k), z))$ and by trying all the nodes x in $N(t)$.

Of course, the algorithm **APSCP-INSERTION** may be used inside a *Monte-Carlo* Scheme as follows:

Parameter Δ :

For $i = 1$ to Δ run the **APSCP-INSERTION** Procedure;

Keep the best result.

This greedy insertion algorithm may now used in order to initialize the following **APSCP-DESCENT** descent algorithm:

Algorithm **APSCP-DESCENT**:

Initialize the tree T through **APSCP-INSERTION**;

Initialize the *filtering threshold value* H ;

- (1): **Search** (in a filtered way) parameter values x, y for the MOVE-RELOAD operator in such a way that applying $\text{MOVE-RELOAD}(x, y)$ to T improves the *Tree-Cost* quantity; **If Success** then **Go To** (1);
- (2): **Search** (in a filtered way) parameter values k, k', l, c for the MOVE-RELOADS operator in such a way that applying $\text{MOVE-RELOADS}(k, k', l, c)$ to T improves the *Tree-Cost* quantity; **If Success** then **Go To** (1);
- (3): **Search** (in a filtered way) parameter values k, l, c for the MOVE-RELOADS1 operator in such a way that applying $\text{MOVE-RELOADS1}(k, l, c)$ to T improves the *Tree-Cost* quantity; **If Success** then **Go To** (1);
- (4): **Search** (in a filtered way) parameter values x, y, l, c for the MOVE-DEMANDS operator in such a way that applying $\text{MOVE-DEMANDS}(x, y, l, c)$ to T improves the *Tree-Cost* quantity; **If Success** then **Go To** (1);
- (5): **Search** (in a filtered way) parameter values x, l, c for the MOVE-DEMANDS1 operator in such a way that applying $\text{MOVE-DEMANDS1}(x, l, c)$ to T improves the *Tree-Cost* quantity; **If Success** then **Go To** (1);
- (6): **Search** (in a filtered way) parameter values x, y, k, l, c for the MOVE-DEMANDS-RELOAD operator in such a way that applying $\text{MOVE-DEMANDS-RELOAD}(x, y, k, l, c)$ to T improves the *Tree-Cost* quantity; **If Success** then **Go To** (1);
- (7): **If** H is small enough then **Stop** else set $H = H/2$ and **go to** (1).

Filtering the search for the good value of the parameter vectors.

In the case of the (1) above instruction, the active nodes x are scanned in an exhaustive way, but the search for the y value is restricted to the neighbourhood set $N(x)$.

In the case of the instruction (2) and (3), the threshold value H is involved as followed:

- the segment l is tried only if the decomposition $\text{RELOAD}(T, k) = l_3 \oplus l \oplus l_4$ is such that $\text{DIST}(\text{Last}(l_3), \text{First}(l))$ and $\text{DIST}(\text{Last}(l), \text{First}(l_4)) \geq H$;
- the cut $c = (l_1, l_2)$ is tried only if $\text{DIST}(\text{Last}(l_1), \text{First}(l_2)) \geq H$.

In the case of the instruction (4) and (5), the threshold value H is involved as followed:

- the segment l is tried only if the decomposition $\text{DEMAND}(T, x) = l_3 \oplus l \oplus l_4$ is such that $\text{DIST}(d(\text{Last}(l_3)), o(\text{First}(l)))$ and $\text{DIST}(d(\text{Last}(l)), o(\text{First}(l_4))) \geq H$;
- the cut $c = (l_1, l_2)$ is tried only if $\text{DIST}(d(\text{Last}(l_1)), o(\text{First}(l_2))) \geq H$.

In the case of the (6) instruction, the threshold value H is involved as in (4) and (5), and the search for y is performed, once $x, k, l, c = (l_1, l_2)$ have been determined inside the neighbour set $N(t)$ of $t = \text{MID}(\text{MID}(\text{Last}(l_1), o(\text{First}(l))), \text{MID}(d(\text{last}(l)), \text{First}(l_2)))$.

Remark: of course, it would be possible to improve the performance of the **APSCP-DESCENT** algorithm by casting it into a scheme like the *Simulated Annealing* scheme or the *Tabu List* scheme. But it is not really the purpose of the paper: as we shall see in Section V, our tree representation of the **APSCP** problem, together with the operators which we just described above, are sufficiently powerful to provide us, under small computing costs, with very good solutions for our **APSCP** problem.

V. Experiments.

We have been performing experiments, on PC IntelXeon with 1.86 GHz, 3.25 Go Ram, while using a Visual Studio C++ compiler, and while focusing on several points:

- the ability of **APSCP-INSERTION** and **APSCP-DESCENT** to get solutions close to the optimal theoretical solutions;
- the running time of those algorithms;
- the characteristics of the solutions: number of reload nodes which appear in the solution, improvement of the *Cost-Tree* value induced by pre-emption;
- the impact of the different local transformation operators on the behaviour of the algorithms.

In order to do this, we performed several tests, while using node sets X and distance matrices DIST proposed by the TSPLIB libraries, and by selecting origin/destination pairs $(o(k), d(k), k \in K)$ in a random way inside the set X . We dealt with instances which involves from 20 to 300 nodes, and from 10 to 100 origin destination pairs, and, in case of small instances, got exact results through the use of the LIP formulation of Section III.3, augmented with cutting planes techniques (see [25, 26]).

Our first experiment is related to the procedure **APSCP-INSERTION**: we run the **APSCP-INSERTION** Monte-Carlo scheme with $\Delta = 100$, and we keep memory, for every test with name INST , of the following quantities:

REF: Optimal theoretical *Tree-cost* value;

MIN (MAX): Minimal (Maximal) *Tree-cost* value obtained through Δ iterations of **APSCP-INSERTION**; MEAN: Maximal (worse) *Tree-cost* value obtained;

EGI: Gap (in %) between REF and the global solution produced by the **APSCP-INSERTION** Monte Carlo scheme (MIN value).

REL: Mean number of reload nodes involved in a solution produced by **APSCP-INSERTION**;

DE/REL: Mean number of demands related to every reload node x (length of the list $\text{DEMAND}(x)$), for x different from *Depot*;

CPU: CPU Mean Time (in **milliseconds**) for any iteration of **APSCP-GREEDY-INSERTION**.

The results which we get may be summarized as follows:

Table 1: Tests performed on 10 instances which we got from the *gr24* instance with 49 nodes of the TSPLIB library by randomly sorting 12 demands, and no reload nodes which is not the depot node, the copy of an origin node $o(k)$ or the copy of a destination node $d(k), k \in 1..12$.

INST	REF	MIN	MAX	MEAN	EGI	REL	DE/REL	CPU
------	-----	-----	-----	------	-----	-----	--------	-----

Gr24_v01	24654	25023	27883	26391	1.5	0.06	2.83	< 15
Gr24_v02	21395	21424	23654	22371	0.136	0.43	1.60	< 15
Gr24_v03	22834	23363	26825	24760	2.32	0.36	2.51	< 15
Gr24_v04	23255	23444	25513	24140	0.813	0.41	2.47	< 15
Gr24_v04	23993	23993	27373	25261	0	0.31	2.03	< 15
Gr24_v06	23233	23233	25584	24427	0	0.54	1.71	< 15
Gr24_v07	20224	20283	22594	20906	0.292	0.11	1.72	< 15
Gr24_v08	20865	21124	23334	21873	1.24	0.61	1.13	15
Gr24_v09	23054	23073	25684	24014	0.0824	0.43	3	< 15
Gr24_v10	26704	26963	29843	28303	0.97	0.16	4.4	15

Table 2: Tests performed on 10 instances which we got from the *hk48* instance with 97 nodes of the *TSPLIB* library by randomly sorting 24 demands, and no reload nodes which is not the depot node, the copy of an origin node $o(k)$ or the copy of a destination node $d(k)$, $k \in 1..24$.

INST	REF	MIN	MAX	MEAN	EGI	REL	DE/REL	CPU
Hk48_v01	358048	375447	405299	387605	4.86	0.97	1.67	< 15
Hk48_v02	280579	291800	325548	306673	4	1.44	1.39	< 15
Hk48_v03	318959	325027	351678	338017	1.9	0.95	3.25	< 15
Hk48_v04	315118	322908	347647	336123	2.47	0.53	2.46	15
Hk48_v04	320578	327709	360167	340639	2.22	0.27	2.80	15
Hk48_v06	306000	318838	351007	334372	4.2	0.59	4.42	< 15
Hk48_v07	314127	330528	370107	347588	5.22	0.52	3.04	16
Hk48_v08	342390	350960	381719	366652	2.5	0.53	4.57	16
Hk48_v09	337327	343127	370387	355734	1.72	0.54	3.24	15
Hk48_v10	330119	339509	373190	355208	2.84	0.73	1.61	16

Table 3: Tests performed on 10 instances which we got from the *gr120* instance with 241 nodes of the *TSPLIB* library by randomly sorting 60 demands, and no reload nodes which is not the depot node, the copy of an origin node $o(k)$ or the copy of a destination node $d(k)$, $k \in 1..60$.

INST	REF	MIN	MAX	MEAN	EGI	REL	DE/REL	CPU
Gr_120_v01	Unknown	327070	344139	335480	*	0.42	5.13	78
Gr_120_v02	Unknown	332679	353240	343622	*	0.64	4.60	78
Gr_120_v03	Unknown	326189	345859	335567	*	0.27	8.95	78
Gr_120_v04	Unknown	366750	380409	374350	*	0.36	5.74	78
Gr_120_v05	Unknown	310179	330002	320326	*	1.53	3.05	78
Gr_120_v06	Unknown	319619	337921	327146	*	0.64	3.24	78
Gr_120_v07	Unknown	285989	302602	293394	*	0.70	4.46	78
Gr_120_v08	Unknown	345100	365379	355230	*	0.56	7.33	78
Gr_120_v09	Unknown	333909	350171	342549	*	0.47	11.11	78
Gr_120_v10	318099	337259	354809	345393	6.02	0.36	9.19	78

Table 4: Tests performed on 10 instances *RELn*, , which we built in such a way that:

- the related instance involves n nodes, $p = (n/2 - 1)/3 - 1$ reload nodes, $(n - p - 1)/2$ demands;
- its optimal value is the sum $\sum_{k \in K} DIST(o(k), d(k))$, and that the related optimal solution involves all the reload nodes.

INST	REF	MIN	MAX	MEAN	EGI	REL	DE/REL	CPU
------	-----	-----	-----	------	-----	-----	--------	-----

REL31	11843	13045	17088	14665	10.1	0.11	0.68	< 15
REL55	17464	19554	23322	21841	12.0	0.35	2.40	16
REL79	21053	24235	28386	26194	15.1	0.54	2.92	31
REL91	22323	26321	29924	27658	17.9	0.54	2.85	47
REL115	24142	28117	31813	30000	16.5	0.91	4.50	78
REL163	26036	30734	35302	32966	18.0	1.76	5.61	141
REL187	26494	32077	36486	34092	21.1	2.87	4.83	187
REL211	26775	32830	36434	34655	22.6	3.39	4.83	250
REL259	27042	33773	38796	35654	24.9	5.92	4.70	375
REL283	27098	33664	37496	36035	24.2	6.86	5.17	453

Comments: We see that the results which we get through application of a combination of a greedy scheme and a Monte-Carlo diversification scheme are most often rather goods, in the sense that its allows us to get in a fast way solutions which are not too far from the best theoretical ones. Still, we also notice that our greedy scheme is in trouble when it comes to pre-emption handling, that means when it comes to creating reload nodes. Thus, the results which derive from the application of **APSCP-INSERTION** get worse as soon as there is an increase of the gap between the optimal pre-emptive optimal value and the non pre-emptive one.

Our second experiment is related to **APSCP-DESCENT**. We run **APSCP-DESCENT** from a solution provided by only 1 application of **APSCP-INSERTION**, and we keep memory, for every test with name INST, of the following quantities:

REF: Optimal theoretical value;

VAL: The cost value obtained after application of **APSCP-DESCENT**;

EGI: Gap (in %) between REF and the solution produced by **APSCP-INSERTION**;

ED: Gap between REF and the solution produced by **APSCP-DESCENT**;

ETDS: Part of the gap between EGI and ED which is induced by the operators MOVE-DEMANDS and MOVE-DEMANDS1 and MOVE-DEMAND-with-RELOAD;

REL: Number of reloads involved in the solution produced by **APSCP-DESCENT**;

TNB: Number of times a local transformation operator is effectively applied inside the **APSCP-DESCENT** process;

CPU: Cpu Running Time (in milliseconds).

The results which we get may be summarized as follows:

Table 5: Tests performed on 10 instances which we got from the gr24 instance with 49 nodes of the TSPLIB library by randomly sorting 12 demands, and no reload nodes which is not the depot node, the copy of an origin node $o(k)$ or the copy of a destination node $d(k)$, $k \in 1..12$.

INST	REF	VAL	EGI	ED	ETDS	REL	TNB	CPU
Gr24_v01	24654	24654	10.3	0	10.3	1	12	93
Gr24_v02	21395	21914	5.0	2.4	2.6	1	3	47
Gr24_v03	22834	22874	9.9	0.1	9.8	1	9	46
Gr24_v04	23255	23435	3.9	0.7	3.2	2	4	31
Gr24_v04	23993	23993	0	0	0	0	0	31
Gr24_v06	23233	23763	8.3	2.2	6.1	0	3	31
Gr24_v07	20224	20244	1.2	0.1	0.2	1	3	78
Gr24_v08	20865	21084	4.9	1.0	3.9	1	6	31
Gr24_v09	23054	23054	4.9	0	4.9	1	7	47
Gr24_v10	26704	26754	4.9	0.2	3.7	1	7	63

Table 6: Tests performed on 10 instances which we got from the hk48 instance with 97 nodes of the TSPLIB library by randomly sorting 24 demands, and no reload nodes which is not the depot node, the copy of an origin node $o(k)$ or the copy of a destination node $d(k)$, $k \in 1..24$.

INST	REF	VAL	EGI	ED	ETDS	REL	TNB	CPU (s)
------	-----	-----	-----	----	------	-----	-----	---------

Hk48_v01	358048	358349	5.2	0.1	5.1	2	18	0.8
Hk48_v02	280579	284411	7.9	1.3	6.3	4	20	1.1
Hk48_v03	318959	322879	5.7	1.2	4.3	2	12	2.0
Hk48_v04	315118	316362	5.1	0.4	4.6	5	24	0.7
Hk48_v04	320578	323508	7.1	0.9	6.1	1	23	3.0
Hk48_v06	306000	310963	12.6	1.6	10.4	5	38	1.4
Hk48_v07	314127	319009	12.9	1.5	11.1	2	28	1.2
Hk48_v08	342390	342551	6.7	0.05	6.6	4	26	1.8
Hk48_v09	337327	338500	6.4	0.3	6.0	3	35	0.9
Hk48_v10	330119	334881	6.4	1.4	4.8	4	19	0.7

Table 7: Tests performed on 10 instances which we got from the *gr120* instance with 241 nodes of the *TSPLIB* library by randomly sorting 60 demands, and no reload nodes which is not the depot node, the copy of an origin node $o(k)$ or the copy of a destination node $d(k)$, $k \in 1..60$.

INST	REF	VAL	EGI	ED	ETDS	REL	TNB	CPU (s)
Gr_120_v01	Unknown	313315	*	*	5.2	6	89	130
Gr_120_v02	Unknown	318870	*	*	8.9	1	116	189
Gr_120_v03	Unknown	314493	*	*	6.2	4	96	125
Gr_120_v04	Unknown	360902	*	*	3.5	3	107	145
Gr_120_v05	Unknown	293613	*	*	9.8	4	99	125
Gr_120_v06	Unknown	303441	*	*	7.7	2	90	80
Gr_120_v07	Unknown	265713	*	*	6.4	4	84	86
Gr_120_v08	Unknown	330823	*	*	6.9	4	77	94
Gr_120_v09	Unknown	314073	*	*	8.5	4	105	70
Gr_120_v10	318099	318913	9.5	0.25	9.1	4	96	103

Table 8: Tests performed on 10 instances *REL_n*, , which we built in such a way that:

- the related instance involves n nodes, $p = (n/2 - 1)/3 - 1$ reload nodes, $(n - p - 1)/2$ demands;
- its optimal value is the sum $\sum_{k \in K} DIST(o(k), d(k))$, and that the related optimal solution involves all the reload nodes.

INST	REF	VAL	EGI	ED	ETDS	REL	TNB	CPU
REL31	11843	11953	16.7	0.9	15.8	4	10	0.04
REL55	17464	17583	27	0.7	36.3	8	28	0.34
REL79	21053	21053	29.9	0	29.9	12	56	1.5
REL91	22323	22605	20.8	1.2	19.6	14	46	2.9
REL115	24142	24225	28.4	0.34	28.4	18	78	8.4
REL163	26036	26279	19.3	0.93	18.3	26	79	25
REL187	26494	26626	26.6	0.49	26.2	30	112	39
REL211	26775	26851	33.1	0.28	30.1	34	134	78
REL259	27042	27067	37	0.09	36.9	42	162	232
REL283	27098	27211	33.1	0.4	32.4	46	202	328

Comments: We first notice that the gap between pre-emption and non pre-emption may greatly differ according to the way **APSCP** instances are generated. Though **APSCP-DESCENT** does not involve any of the classical control mechanisms which allow dealing with local optima (Simulated Annealing, Tabou Search...), we see that the operators which derive from our tree representation enable us to get very satisfactory results in a very short time.

VI. Conclusion.

We have been dealing here with a pre-emptive demand routing problem with capacity constraints, and we showed how it was possible to turn it into a non constrained tree construction problem in such a

way that we could solve it in an efficient way through simple greedy and descent processes. It would be interesting to extend the approach which we presented here in a very specific context, and try to deduce efficient approaches for the handling of pre-emption in more general routing and scheduling problems.

VII. Bibliography.

- [1] S. Anily, M. Gendreau, and G. Laporte. The preemptive swapping problem on a tree. Technical report, Les Cahiers du GERAD, G-2005-69, 2006.
- [2] S. Anily and R. Hassin. The swapping problem. *Networks*, 22(4):419–433, 1992.
- [3] N. Ascheuer, L. Escudero, M. Grötschel, and M. Stoer. A cutting plane approach to the sequential ordering problem (with applications to job scheduling in manufacturing). *SIAM Journal on Optimization*, 3:25–42, 1993.
- [4] N. Ascheuer, M. Jünger, and G. Reinelt. A Branch & Cut algorithm for the Asymmetric Traveling Salesman Problem with Precedence Constraints. *Computational Optimization and Applications*, 17:61–84, 2000.
- [5] M.J. Atallah and S.R. Kosaraju. Efficient Solutions to Some Transportation Problems with Applications to Minimizing Robot Arm Travel. *SIAM Journal on Computing*, 17:849, 1988.
- [6] E. Balas, M. Fischetti, and W. Pulleyblank. The precedence constrained asymmetric traveling salesman problem. *Mathematical Programming*, 68:241–265, 1995.
- [7] G.Berbeglia, J.F.Cordeau, I.Gribkovskaia, and G.Laporte. Static pickup and delivery problems: a classification scheme and survey. *TOP: An Official Journal of the Spanish Society of Statistics and Operations Research*, 15(1):1–31, July 2007.
- [8] C. Bordenave, M. Gendreau, and G. Laporte. A branch-and-cut algorithm for the preemptive swapping problem. Technical Report CIRRELT-2008-23, 2008.
- [9] C. Bordenave, M. Gendreau, and G. Laporte. Heuristics for the mixed swapping problem. Technical Report CIRRELT-2008-24, 2008.
- [10] S.Chen and S.Smith. Commonality and genetic algorithms. Technical Report CMU-RI-TR-96-27, Robotics Institute, Carnegie Mellon University, Pittsburgh, PA, December 1996.
- [11] J.F. Cordeau, M. Iori, G. Laporte, and J.J. Salazar-González. A branch-and-cut algorithm for the pickup and delivery traveling salesman problem with LIFO loading. *Submitted to publication*, 2006.
- [12] J.F.Cordeau and G.Laporte. The dial-a-ride problem: models and algorithms. *Annals of Operations Research*, 153(1):29–46, 2007.
- [13] C.E. Cortés, M Matamala, and C.Contardo. The Pickup and Delivery Problem with Transfers: Formulation and Solution Approaches. In *VII French – Latin American Congress on Applied Mathematics*. Springer, 2005.
- [14] I.Dumitrescu. Polyhedral results for the pickup and delivery travelling salesman problem. *Tech. Rep.*, CRT-2005-27, 2005.
- [15] M.T.Fiala Timlin. Precedence constrained routing and helicopter scheduling. *M. Sc. Thesis, Department of Combinatorics and Optimization University of Waterloo*, 1989.
- [16] M.T.Fiala Timlin and W.R.Pulleyblank. Precedence constrained routing and helicopter scheduling: heuristic design. *Interfaces*, 22:100–111, 1992.
- [17] G.N. Frederickson and DJ Guan. Preemptive Ensemble Motion Planning on a Tree. *SIAM Journal on Computing*, 21:1130, 1992.
- [18] G.N. Frederickson and D.J.Guan. Nonpreemptive ensemble motion planning on a tree. *Journal of Algorithms*, 15(1):29–60, 1993.
- [19] G.N. Frederickson, M.S. Hecht, and C.E. Kim. Approximation Algorithms for Some Routing Problems. *SIAM Journal on Computing*, 7:178, 1978.
- [20] L.M. Gambardella and M. Dorigo. An ant colony system hybridized with a new local search for the sequential ordering problem. *INFORMS Journal on Computing*, 12(3):237–255, 2000.
- [21] L. Gouveia and P. Pesneau. On extended formulations for the precedence constrained asymmetric traveling salesman problem. *Networks*, 48(2):77–89, 2006.
- [22] P.Healy and R.Moll. A new extension of local search applied to the Dial-A-Ride Problem. *European Journal of Operational Research*, 83(1):83–104, 1995.

- [23] H.Hernández-Pérez and J.Salazar-González. The multicommodity one-to-one pickup-and-delivery traveling salesman problem. *Submitted to European Journal of Operational Research*, 2008.
- [24] B.Kalantari, A.V.Hill, and S.R.Arora. An algorithm for the traveling salesman problem with pickup and delivery customers. *European Journal of Operational Research*, 22:377–386, 1985.
- [25] H.L.M. Kerivin, M. Lacroix, and A. R. Mahjoub. Models for the single-vehicle preemptive pickup and delivery problem. *Submitted to Journal of Combinatorial Optimization*, 2007.
- [26] H.L.M. Kerivin, M. Lacroix, and A.R. Mahjoub. The Eulerian closed walk with precedence path constraints problem. Technical Report LIMOS/RR-08-03 (also submitted for publication in *SIAM Journal of Computing*), 2007.
- [27] S. Lin. Computer solutions to the traveling salesman problem. *Bell System Technical Journal*, 44:2245–2269, 1965.
- [28] S. Lin and B. W. Kernighan. An effective heuristic algorithm for the traveling salesman problem. *Operations Research*, 21(2):498–516, 1973.
- [29] J. Little, K. Murty, D. Sweeney, and C. Karel. An algorithm for the traveling salesman problem. *Operations Research*, 11(6):972–989, 1963.
- [30] S. Mitrovic-Minic. Pickup and delivery problem with time windows: A survey. Technical Report SFU CMPT TR 1998-12, May 1998.
- [31] S. Mitrovic-Minic and G. Laporte. The pickup and delivery problem with time windows and transshipment. *INFOR*, 44:217–227, 2006.
- [32] R. Montemanni, D.H. Smith, and L.M. Gambardella. A heuristic manipulation technique for the sequential ordering problem. *Computers & Operations Research*, 35(12):3931–3944, 2008.
- [33] P. Oertel. Routing with Reloads. *Doktorarbeit, Universität zu Köln*, 2000.
- [34] S.N. Parragh, K.F. Doerner, and R.F. Hartl. A survey on pickup and delivery problems: Part II: Transportation between pickups and delivery locations. *Journal für Betriebswirtschaft*, 58(1):21–51, 2008.
- [35] H. N. Psaraftis. A Dynamic Programming Solution to the Single-Vehicle Manyto-Many Immediate Request Dial-a-Ride Problem. *Transportation Science*, 14: 130–154, 1980.
- [36] H.N. Psaraftis. k-interchange procedures for local search in a precedence constrained routing problem. *European Journal of Operational Research*, 13(4): 391–402, August 1983.
- [37] J.Renaud, F. Boctor, and G.Laporte. Perturbation heuristics for the pickup and delivery traveling salesman problem. *Computers & Operations Research*, 29(9):1129–1141, 2002.
- [38] J.Renaud, F. Boctor, and J.Ouenniche. A heuristic for the pickup and delivery traveling salesman problem. *Comput. Oper. Res.*, 27(9):905–916, 2000.
- [39] K. M. Ruland and E. Y. Rodin. The pickup and delivery problem: Faces and branch-and-cut algorithm. *Computers and Mathematics with Applications*, 33:1–13, 1997.
- [40] M. W. P. Savelsberg and M. Sol. The general pickup and delivery problem. *Transportation Science*, 29(1):17–29, 1995.