



HAL
open science

Special Synchronous Linear Actuators. Structures and Performances

Hamid Ben Ahmed, Laurent Prevond, Bernard Multon, Benoit Salamand,
Jean Lucidarme

► **To cite this version:**

Hamid Ben Ahmed, Laurent Prevond, Bernard Multon, Benoit Salamand, Jean Lucidarme. Special Synchronous Linear Actuators. Structures and Performances. Electromotion, 1998, Vol.5, pp.93-101. hal-00674074

HAL Id: hal-00674074

<https://hal.science/hal-00674074>

Submitted on 27 Feb 2012

HAL is a multi-disciplinary open access archive for the deposit and dissemination of scientific research documents, whether they are published or not. The documents may come from teaching and research institutions in France or abroad, or from public or private research centers.

L'archive ouverte pluridisciplinaire **HAL**, est destinée au dépôt et à la diffusion de documents scientifiques de niveau recherche, publiés ou non, émanant des établissements d'enseignement et de recherche français ou étrangers, des laboratoires publics ou privés.

SPECIAL SYNCHRONOUS LINEAR ACTUATORS. STRUCTURES AND PERFORMANCES.

Ben Ahmed, H., Prévond, L.(*), Multon, B., Salamand, B. and Lucidarme, J.(*)
Laboratoire d'Electricité Signaux et Robotique (LESiR, URA CNRS 1375)
ENS Cachan - Antenne de Bretagne, Campus de Ker Lann, 35170 Bruz, France
(*) ENS Cachan, Campus de Cachan, 61, avenue du Président Wilson 94235 Cachan, France
E-mail: benahmed@bretagne.ens-cachan.fr

Keywords: Linear actuators – Permanent magnets – Variable reluctance – Flux switching - Multi-airgap.

Abstract: The linear displacement of a mechanical load can be carried out with several processes by either indirect or direct linear actuators. For long (and possibly unlimited) courses, the direct drives perform better, with the linear induction machines and the synchronous machines being better adapted. For small strokes, electromagnets and voice-coil actuators prove to be the most suitable.

This paper focuses primarily on synchronous linear drives. After recalling the main selection criteria for linear actuators, we briefly present the various possible topologies of synchronous actuators. Several examples of linear electrical structures to be developed, especially those at the LESiR facility, as well as their performances are then provided. In particular, we will describe two original structures and their respective performances: a low-cost actuator called "flux-switching", and multi-air gap structures which allow attaining a high specific thrust.

I - INTRODUCTION

Many applications require some linear actuators. Constraints in their design can be of the following types:

- low cost;
- ease of manufacturing;
- positioning performance (curling of effort, linearity); and
- a very high specific thrust.

For each of these constraints, at least one more specifically-adapted topology [1 to 7] does exist. Within the scope of this paper, we will only concentrate upon synchronous direct drives which therefore require a position sensor (either direct or indirect), along with an electronic supply and command. However, before presenting some special structural examples, it would appear necessary from our perspective to highlight the various possible choices with respect to developing linear drives.

II - SELECTION CRITERIA FOR LINEAR DRIVES

II-1. Indirect vs. direct linear drives?

At the present time, it is already possible to establish a summary ranking, according to the transmission pattern of the movement:

- the indirect linear drives have been designed from a rotating electric motor as well as from a mechanical transmission that transforms the rotation movement into a translation movement;
- in contrast, the direct linear drives naturally produce a linear movement.

The systems of movement conversion used in the indirect linear drives are of the "pinion and rack" type or of the "screw and nut" type. The major disadvantages of these devices are:

- their low efficiency (30% to 40%), except for systems using ball screws (a 90% to 95% efficiency);
- the mechanical air-gap along with the difficulties associated with positioning accuracy;

- the acoustical noise;
- difficulties in integrating the actuators into the complete system (rise of the total volume);
- typically lower accelerations;
- a lower maximum speed limit; and
- lack of reversibility in the screw-nut systems.

Their primary advantage generally lies in their reduced cost due to the use of conventional and low-volume rotating electric motors. In fact, the possibility of reaching relatively high operating speeds for the rotating motor enables minimizing the torque to be converted and thus leads to a decrease in both its mass and its cost.

An example of an indirect actuator is presented in the following figure.

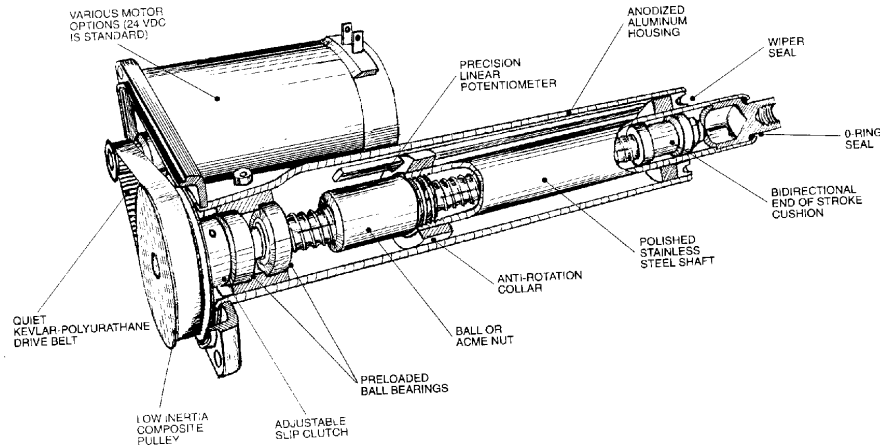

Figure 1: Example of indirect linear actuator [Type 6B.125 of Ultra Motion]

These main features and performances are displayed in table 1.

Supply voltage (V)	24 VDC
Associated mechanical system	Ball screw and nut
Speed reduction	Transmission strap 1/6
Stroke (mm)	200
Speed (m/s)	0.051
Average value of thrust (N)	220
Specific thrust (N/dm ³)	880

Table 1: Example of an indirect linear actuator's characteristics [Type 6B.125 of Ultra Motion]

The direct linear drives are of essentially two types, in accordance with the length of the displacement they are capable of producing.

For very small displacements (a few mm up to about several cm), single- or double-effect electromagnets and voice-coil actuators are normally used (see Figure 2). They present the advantage of being extremely simple and, in particular, of being supplied by either a single coil or two coils. In contrast, their volume tends to be highly proportional to the mechanical energy converted (product of thrust by course) on a full stroke, a feature which quickly leads to prohibitive volumes for major displacements or high thrust.

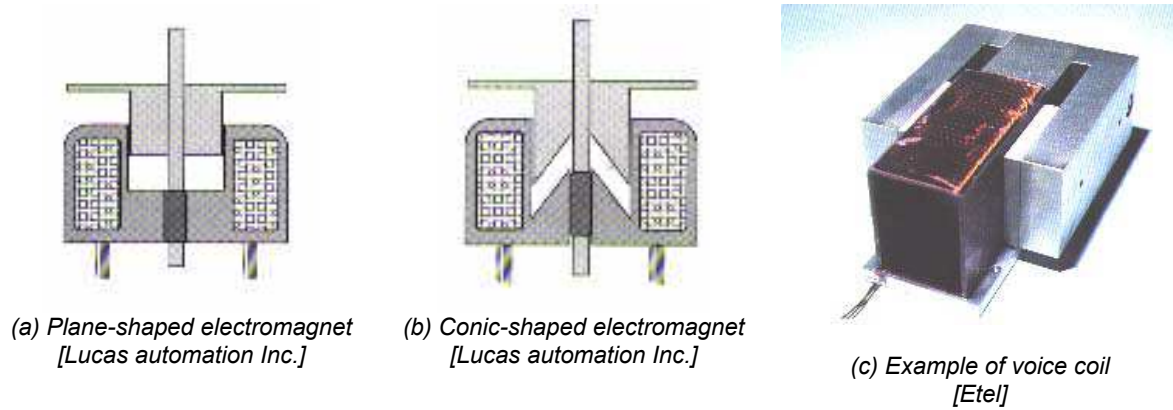

Figure 2: Examples of low-stroke actuators

For long or even unlimited strokes, the electromagnetic structures founded on the same principles as those for the rotating machines are used. The type of rotating structure involved herein is in fact unrolled.

Linear direct drives are faster than systems using ball screws yet remain more accurate and more reliable. Their accuracy depends only on position sensor performances. As a result, these actuators are basically found in applications as a positioning stage, as curve tracers, as drives for machine tools, etc.

Thus, Figure 3 presents an example of a positioning stage driven by a direct synchronous multiple-phased PM linear drive. Magnets have been arranged on the two internal sides facing the stator in a U-shape, with coils on the mobile part. The tray moves on an air bearing. With a laser interferometer as a position sensor, the accuracy of the positioning is lower than 10^{-6} mm.

Another example of direct linear actuators is the one found in the systems of the three-dimensional positioning presented in Figure 4. The main features and performances of this motor are given in Table 2.

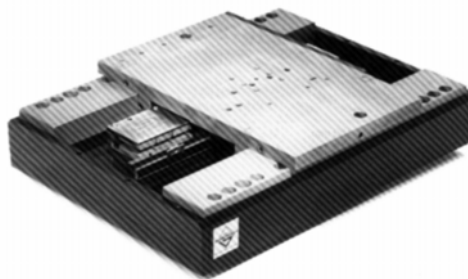

Figure 3 Example of positioning stage [Type ATS8000 of Aerotech]

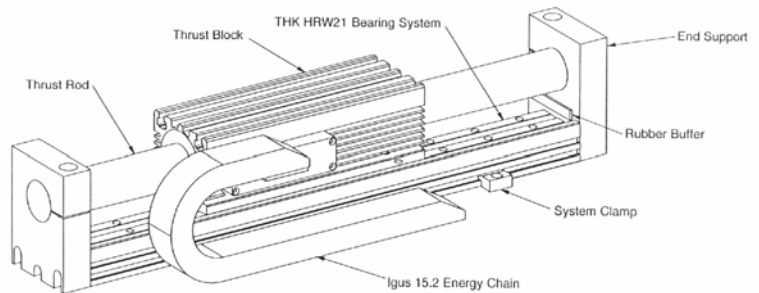

Figure 4 Example of direct linear actuator [Type LD3810 of Linear drivers]

Air-gap (mm)	2
Maximal stroke (mm)	2054
Maximal speed (m/s)	2.6
Average stresst (N)	326
Peak value of stress (N)	1300
Specific stress (N/cm ²)	0.72

Table 2: Example of a direct linear actuator's characteristics [Type LD3810 of Linear Drives]

II-2. Type of arrangement?

Besides the principles of electromechanical conversion, two types of architecture can be distinguished:

- a fixed armature and mobile inductor; and
- a mobile armature and fixed inductor.

However, each one of these architectures can display:

- an armature that's interdependent of the rail; and
- an inductor that's interdependent of the rail.

Yet, it still remains possible to obtain, as we will observe hereafter:

- a surrounding rail; and
- a surrounded rail.

Among the eventual combinations, the three most common are:

- a) The rail is a fixed inductor (Figure 5a); the mobile armature requires feeding from the part in displacement (the "mover"). This feeding may be accomplished either by a flexible cable (limited movement) or by a transmission of energy without contact; another possibility is for the energy to be loaded.
- b) The rail is an inductor and is mobile (Figure 5b): in this case, the inductor is often performed by permanent magnets. This avoids a supply of the mobile part, yet requires running the permanent magnet rail over the entire length. The cost herein becomes particularly excessive for large displacements.
- c) The rail is a fixed armature (Figure 5c): in this case, the "mover" supports only the inductor (the Japanese solution to the "maglev" train). The energy is thus brought to the fixed part, which avoids any difficulty of transmission to the mobile device; however, the supply system is complex and expensive in that the armature must be opened over the entire length of the displacement, which signifies that a large number of windings are necessary.

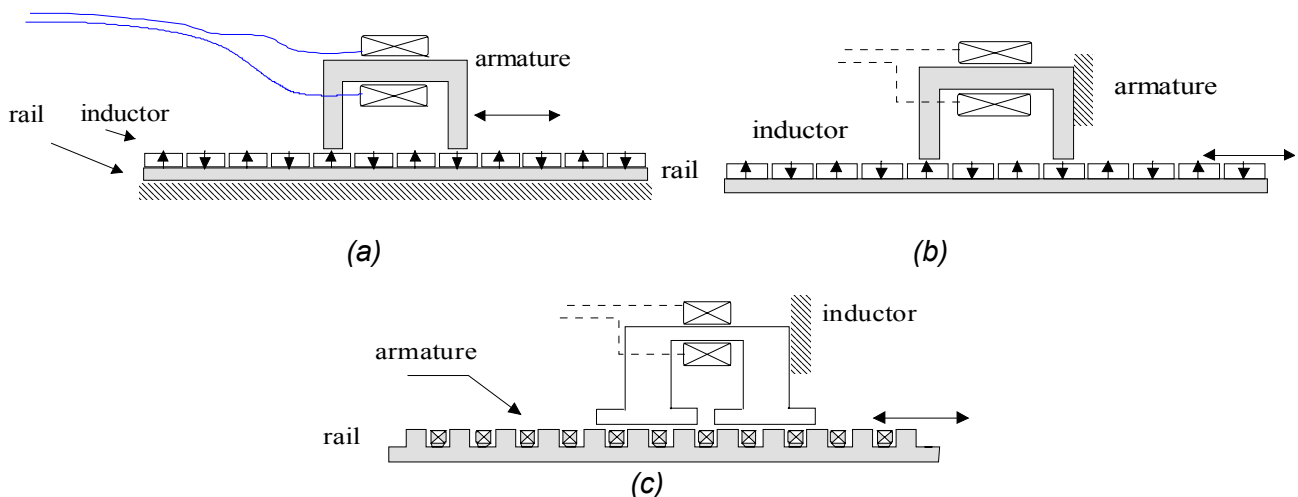

Figure 5: Several primary arrangements of synchronous linear actuators

II-3. Problems of linear guidance

In the rotating machines, the concentric lay-out of structures with respect to the radial field serves to make the mechanical guidance more comfortable; ball-bearings or the smooth landings can then be used. A good level of concentricity in the rotor in relation to the stator

enables balancing the normal magnetic stresses, thereby limiting the flattening of bearings. In the case of linear systems, guidance performed between the generally plane surfaces is more complex and raises many mechanical difficulties. The normal magnetic stresses are indeed typically much greater than the useful stresses tangent to the displacement (ratio of 10 to 50) and generate normal magnetic pressures on the order of 40 to 100 N/cm² over the air-gap surface.

With a flat stator, these efforts are far from being negligible and can reach in the range of several thousands of Newtons, thus creating some jerky movements. In contrast, with stators in a U-shape (Figure 6a) or even tubular (Figure 6b), these high efforts which generate some axial or radial instabilities, disappear provided that the mobile part is perfectly centered in order to create an air-gap that's strictly identical.

It is therefore necessary to obtain a very accurate mechanical guidance. Generally, this is transferred and then bound to the actuator's load. This guidance should display as low of a rubbing coefficient as possible, especially in those applications where the loaded mass is sizable.

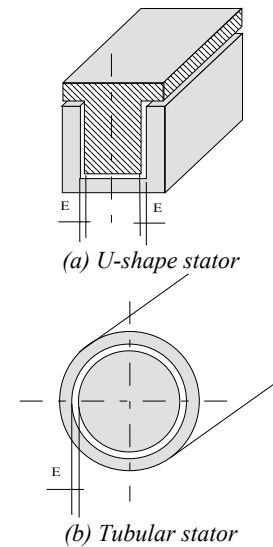

Figure 6: Centered linear geometry

II-4. Electromagnetic principles

Linear induction motors (Figure 7): Induction motors present the following details. When a movement regulation is not necessary, these motors can then be supplied directly by the alternative network, which offers maximal savings (no electronic supply and only simple electromagnetic structures).

However, should a movement control be sought, these motors present an overly-low power factor, especially in the low-power range (oversizing of the electronic converter), along with a mediocre efficiency. In the case of a mobile primary architecture, the rail can be both sufficiently simple and economical because it must be a conductor and ferromagnetic at the same time; the ideal would consist of an unrolled "squirrel cage".

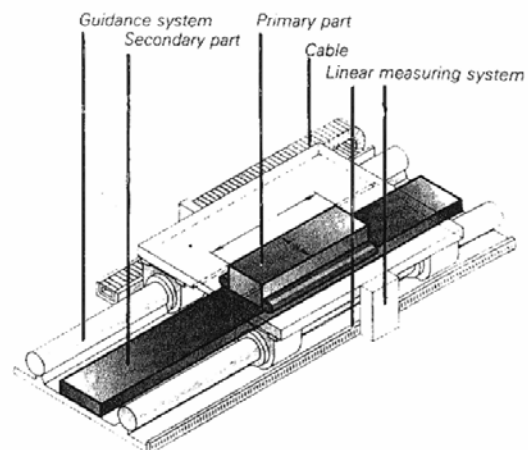

Figure 7: Example of an induction linear actuator [8]

Synchronous type motors: It is within this family of motors that the largest diversity as well as the greatest development possibilities are encountered; these motors will be the focus of the remaining sections of this paper.

III - PRINCIPALS OF ENERGY CONVERSION

It has been shown [9] that the average motor stress value is bound directly to the energy converted ΔW_m over an electric period. This size corresponds to the area delimited by the operating cycle described in the flux-mmf position diagram. The value of ΔW_m depends on the variation in the flux linkages. In synchronous actuators, the flux variation can be obtained very well on the basis of:

- a reluctance variation (Figure 8a): reluctance coupling;
- a variation in the excitation induction (Figure 8b): PM coupling; or
- the combination of the two processes (Figure 8c): hybrid coupling.

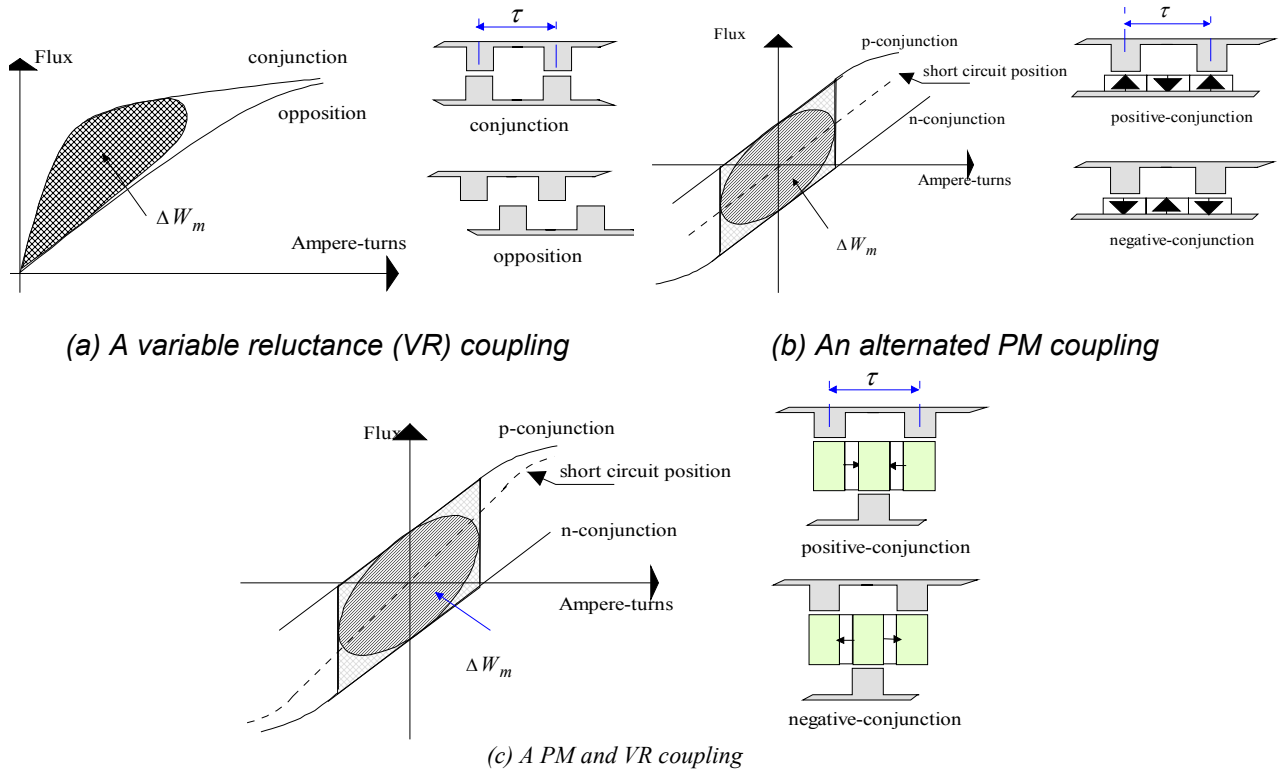

Figure 8: Different electromagnetic couplings

The average motor stress value for a structure that includes m phases and whose coupling pitch (length of displacement corresponding to a complete cycle) is noted by τ can therefore be expressed by the simple relation:

$$\langle F_t \rangle = m \frac{\Delta W_m}{\tau}$$

An intrinsic characteristic of the performance of an actuator is the magnetic shear stress $\langle \sigma_t \rangle$. This characteristic can be described by the following expression:

$$\langle \sigma_t \rangle = m \frac{\Delta W_m}{\tau} \frac{1}{S_e} \quad \text{where } S_e \text{ represents the air-gap surface.}$$

IV – VARIOUS SYNCHRONOUS TOPOLOGIES

Electric actuators can be distinguished by virtue of two fundamental features:

- the type of electromagnetic motor coupling; and
- the size of the armature in relation to the motor's coupling pitch.

Regarding the first feature, we specified in Section III the various coupling types in existence. As far as the second feature is concerned, the two following characteristic parameters are necessary:

- the shape factor of the armature that corresponds to the ratio of the diameter's average coil value (denoted l_w), and the characteristic dimension of the winding section (denoted d_w); and
- the motor's coupling pitch, as given by the ratio l_w , and the inductor's pitch τ .

From these two parameters, four types of topology can be defined:

- $l_w/d_w \gg 1$ and $l_w/\tau \approx 1$: distributed winding and polar coupling topology (classical machines in which the tooth coupling represents a parasitic phenomenon, see Figure 9a);
- $l_w/d_w \gg 1$ and $l_w/\tau \ll 1$: distributed winding and tooth coupling topology (Vernier synchronous machines [10], see Figure 9b);
- $l_w/d_w \approx 1$ and $l_w/\tau \approx 1$: tooth winding topology (SRM, fan PM motors, see Figure 9c); and
- $l_w/d_w \approx 1$ and $l/\tau \gg 1$: global winding topology ("claw-pole" machine [12], alternated PM motor [13], see Figure 9d).

The last two topologies are both necessarily tooth couplings. It then becomes essential to display stator and/or rotor salience. In contrast, concerning the global coil topology, it is possible to define a representative elementary pattern of the active zone. The width of such a pattern will then correspond to the tooth pitch.

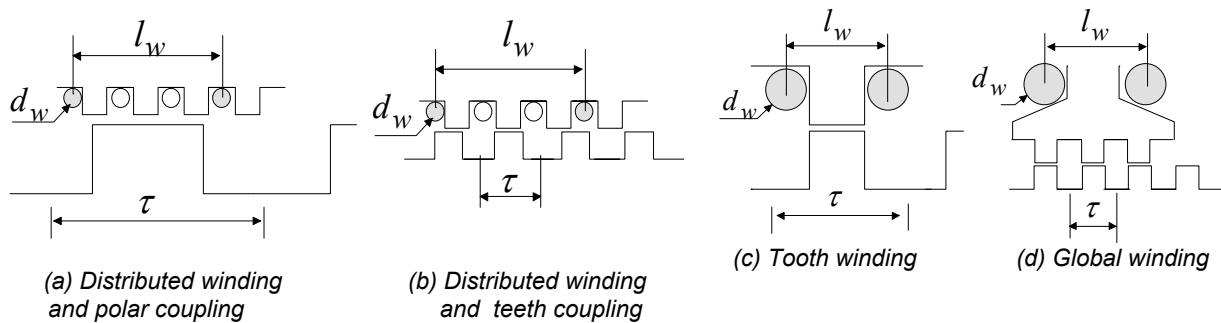

Figure 9: Various topologies

It should also be pointed out, however, that with respect to displacement, two magnetic field configurations of armatures are indeed possible:

- the so-called "perpendicular field configuration" whose magnetic flux is globally perpendicular to the displacement (see Figure 10a); and
- the so-called "longitudinal field configuration" [14] whose magnetic flux is globally parallel to the displacement (see Figure 10b).

The characteristic positions of the maximum flux and the minimum flux are thus inverted from one configuration to the other. The tooth widths in relation to the tooth step are also "inverted":

$$\frac{\tau_s}{\tau} < 0.5 \quad : \text{perpendicular field configuration}$$

$$\frac{\tau_s}{\tau} > 0.5 \quad : \text{longitudinal field configuration}$$

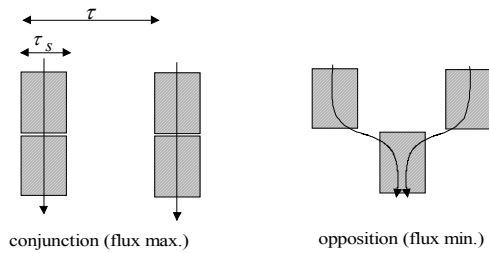

Figure 10a Perpendicular field configuration

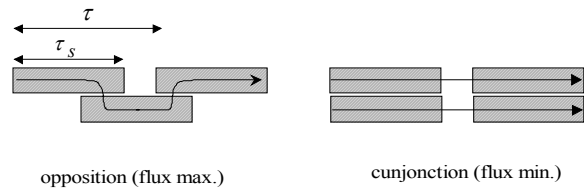

Figure 10b Longitudinal field configuration

In the case of global winding topology, airgaps are :

- in parallel in perpendicular field configuration,
- in series in longitudinal field configuration.

This last configuration is very interesting in multi-airgap structure (see § V-3).

V – EXAMPLES OF SPECIAL SYNCHRONOUS STRUCTURES

In what follows, some specific structures, which are essentially based on topologies (c) and (d) and which use the couplings designed at the LESiR noted previously, will be presented.

V-1. Variable reluctance or alternated PM structures

This section focuses on the design conditions governing electric actuators subjected to a heavy cost constraint. Such a constraint takes on even greater significance with respect to robotics applications and/or long-displacement applications. A classical synchronous structure would impose the development of a "complex" winding, along with a long active inductor (including excitation magnets or coils). In order to overcome these two disadvantages, it is possible to design global winding structures exhibiting a simple, solenoid shape (thereby enabling a good filling factor of winding area of the valuable copper), along with a passive rail (inductor) which includes neither a coil nor a permanent magnet. Several structural configurations could be foreseen.

Within this framework, three linear structures have been designed as follows:

- perpendicular field VR structure (Figure 11);
- longitudinal field VR structure (Figure 12); and
- fixed alternated PM structure (Figure 13).

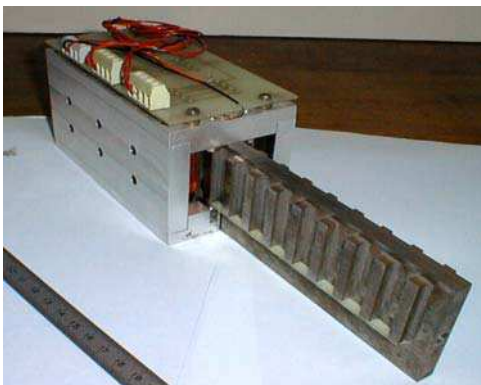

Figure 11 Polyphased perpendicular VR actuator

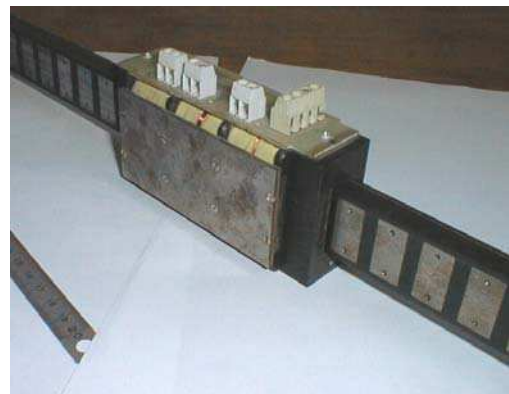

Figure 12 Polyphased longitudinal VR actuator

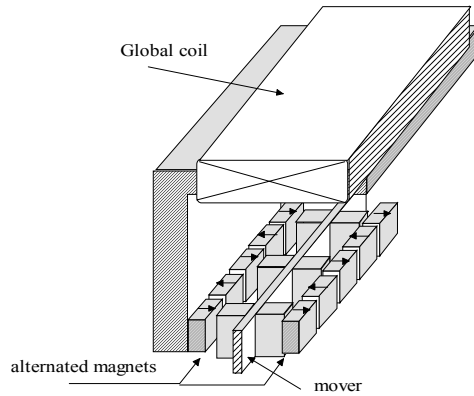

Figure 13: Longitudinal cross-section of a fixed alternated PM actuator

V-2. Flux-switching structures

With the same objective of cost minimization (passive rail), a so-called "flux-switching" structure, whose principle is described in the following figures, has been designed [15].

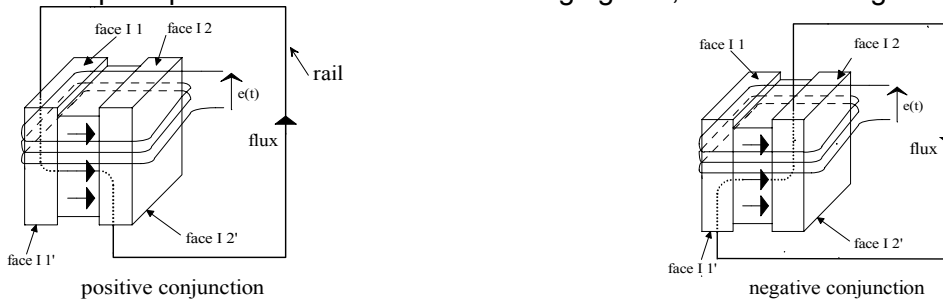
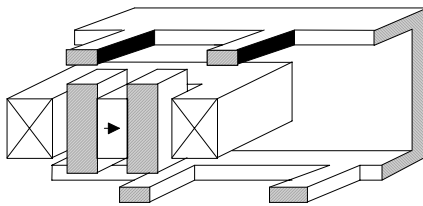

Figure 14 Principle of "flux-switching"

Two kinds of solutions can be discerned: surrounding rail (mobile inside part, Figures 15a and 15b), and surrounded rail (mobile outside part, Figure 15c).



(a) Surrounding-rail actuator



(b) Photograph of a surrounding-rail actuator

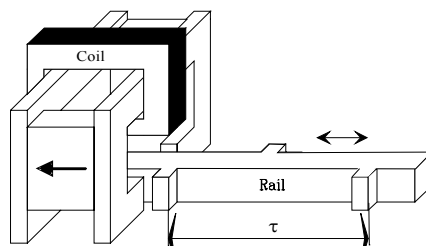

(c) Surrounded-rail actuator

Figure 15: Example of "flux-switching" actuators

The sizes and performances of actuators (a) and (c) are given in Table 3 [16].

Structures	Surrounding-Rail	Surrounded-Rail
Magnets thickness (mm)	6	5
Tooth pitch (mm)	20	18
Air-gap (mm)	0.5	0.4
Type of magnets	Ferrite (0.35T)	NdFeB (0.65 T)
Ampere-turns (AT)	800	1560
Specific stress (N/cm ²)	1.3	3.7
Average stress (N)	8	9.7

Table 3: Sizes and performances of the (a) and (c) actuators

Structures called "soft flux-switching" (see Figures 16a and 16b) can also be designed; their main specificity lies in the variation of the inductor flux necessary for the creation of a motor stress. This variation is in fact obtained from the progressive modulation of the air-gap, as shown in the figure below. The small variation in reluctance generates a low variation in the induction present in the rail (Figure 16c) and therefore serves to moderate the iron losses.

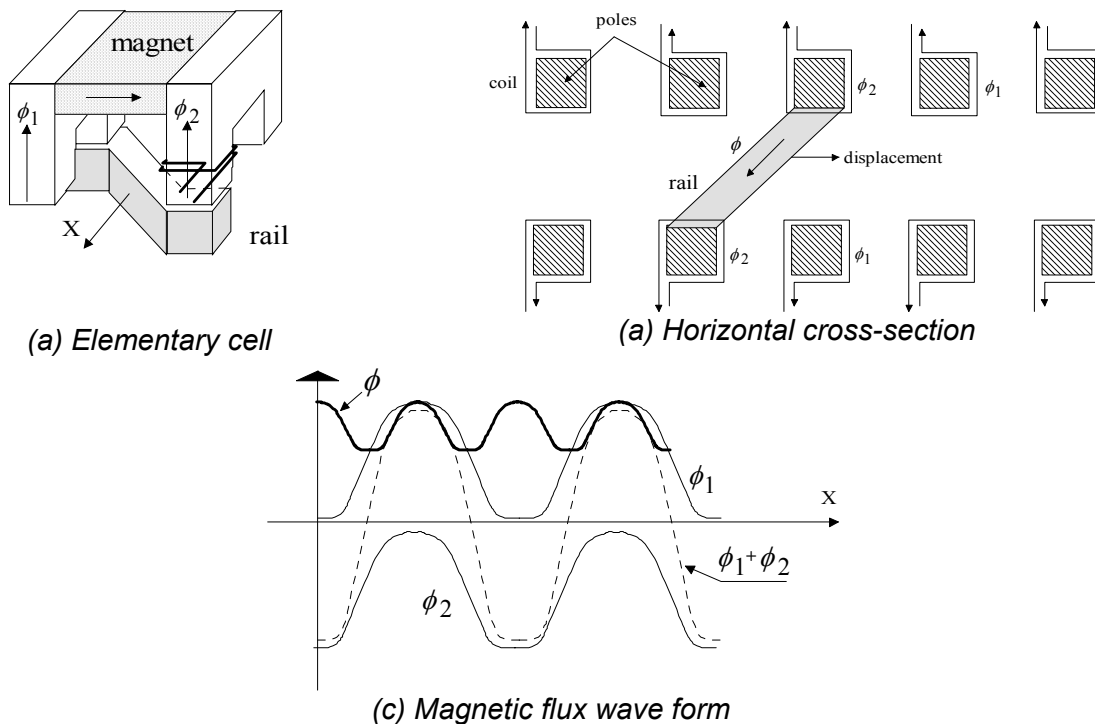

Figure 16: "Soft flux-switching" actuator

Remarks:

- ① Some applications do require a high displacement speed combined with a great ease of manufacturing.

The minimization of stator iron losses is thus achieved by creating a massive magnetic circuit of iron powder [17]. An example of such a magnetic characteristic is shown in Figure 17. This technology does make it possible to generate, by means of milling, complex-shaped magnetic circuits.

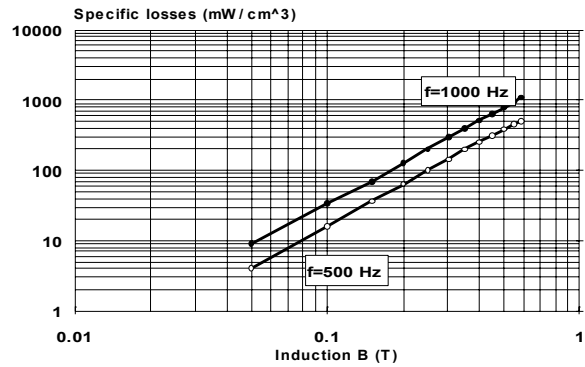

Figure 17: Example of specific iron losses from the iron powder [Type F75 of SAGEM]

② The global winding associated with the iron powder technology also allows developing very small structures with just a few parts.

An example of such a rotating structure is shown in Figure 18. This actuator possesses an outside diameter of 11 mm and a length of 11.5 mm. It develops a torque of 0.1 mNm for a speed of 10,000 rpm [18].

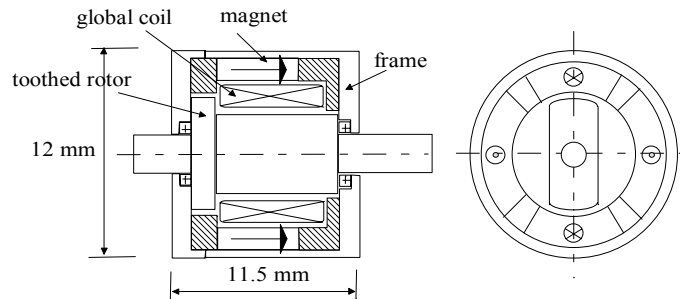

Figure 18: Small rotating actuator

V-3. High specific-thrust structures

In the case of global coil structures and based upon the fundamental principle of energy conversion, it can be demonstrated that the homothetic reduction by a k factor (< 1) in the size of the elementary pattern (whose length is equal to the pitch value) modifies the electromagnetic energy converted on a pitch from the elementary pattern by a factor of k^2 . Nevertheless, this reduction in size enables multiplying the total number of patterns in a single active volume by $\frac{1}{k^2}$. The total energy converted therefore gets preserved. The reduction in the pitch value (hence the increase in the conversion frequency) under the same conditions of feeding and cooling would then, in theory, allow increasing the thrust by a factor of $\frac{1}{k}$.

Two linear actuators based on this principle have already been developed:

-The first is a longitudinal field VR structure (Figure 19) whose elementary pattern is given in Figure 10b. The structure possesses 26 air-gap surfaces. The fixed and mobile active parts correspond to blades, which include the magnetic teeth, as represented in Figure 20. The blades are rubbing.

The total mass of the active part is 2 kg. The displacement is 40 mm with a tooth pitch value of 6 mm. The thrust obtained under warm-up conditions in the continuous regime is 1.200 N [19]. This exceptional specific thrust was made possible thanks both to a major division of the active zone and to the guidance principle: guidance by rubbing.

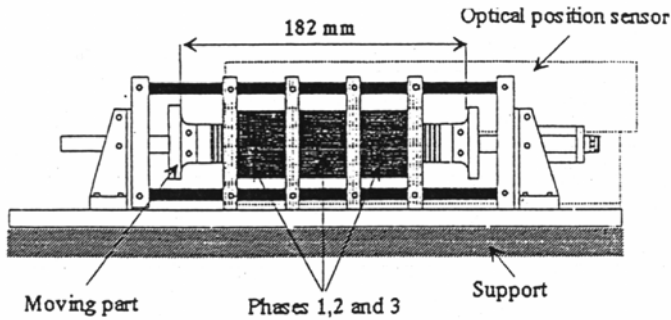

Figure 19 Multi-airgap longitudinal VR actuator

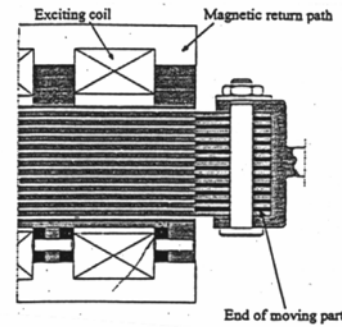

Figure 20 Extremity of actuator

-The second structure is composed of permanent magnets (NdFeB, 0.65T) and is based on longitudinal field principal [20]. The elementary pattern is represented in Figures 21a and 21b. The inductor (the part in displacement) is passive. It is constituted of ferromagnetic stars (Figure 21c). Both the permanent magnets and the winding are fixed.

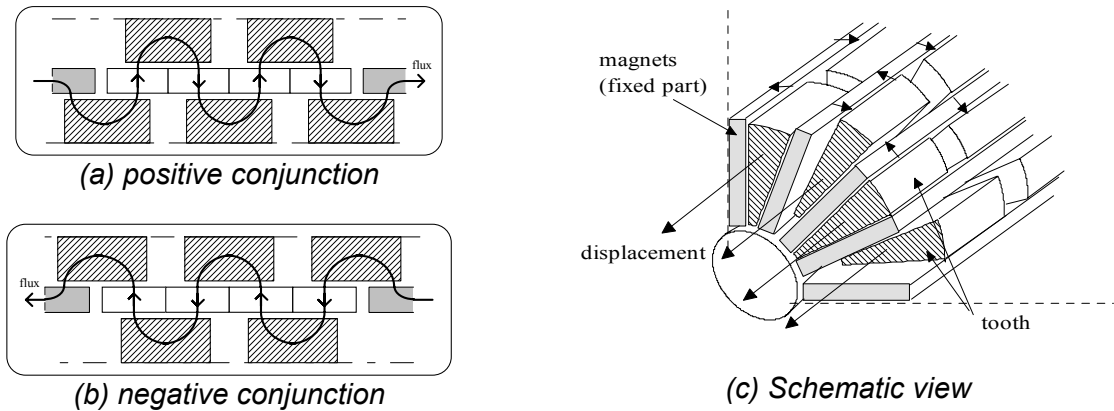

Figure 21: Multi-airgap longitudinal PM actuator

The structure possesses 36 air-gap surfaces (see Figure 22). The displacement is 55 mm with a tooth pitch value of 13 mm. The structure is developed under air cooling conditions and a thrust of 2,000 N. The outside diameter is 210 mm and the length of the active part is 280 mm.

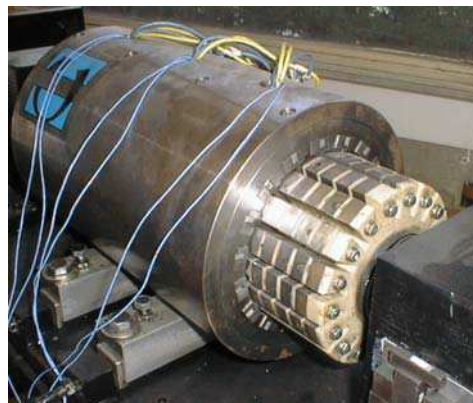

Figure 22: Photograph of the multi-airgap longitudinal PM actuator
[This prototype was built by Radio-Energie]

It should be emphasized herein that the major disadvantage of multi-air gap structures lies in the difficulties of mechanical development, due to the necessity of splitting the active zone

and of decreasing the mechanical air gap, and hence of being able to cope with these difficulties regardless of the inductor's position on the subsequent strokes.

VI - LINEAR ACTUATOR TESTING APPARATUS

In order to characterize a linear actuator (acceleration, stress, rubbing, etc.), a specific testing apparatus is necessary. Two major obstacles are encountered herein:

- the limitation of the stroke; and
- the measurement of thrust in the transient regime (acceleration and braking), within an established regime and a static regime.

To overcome these two obstacles, we have developed at the LESiR two linear actuator test set-ups: one for low thrust (see Figure 23a), while the other for high thrust (> 2.000 N). The force measurement, for both set-ups, is performed by a reaction on a frame suspended by metallic wires (see Figure 23b). A force sensor is then placed between the frame and the fixed part of the actuator (stator). This process allows avoiding any possible rubbing between the stator and the frame.

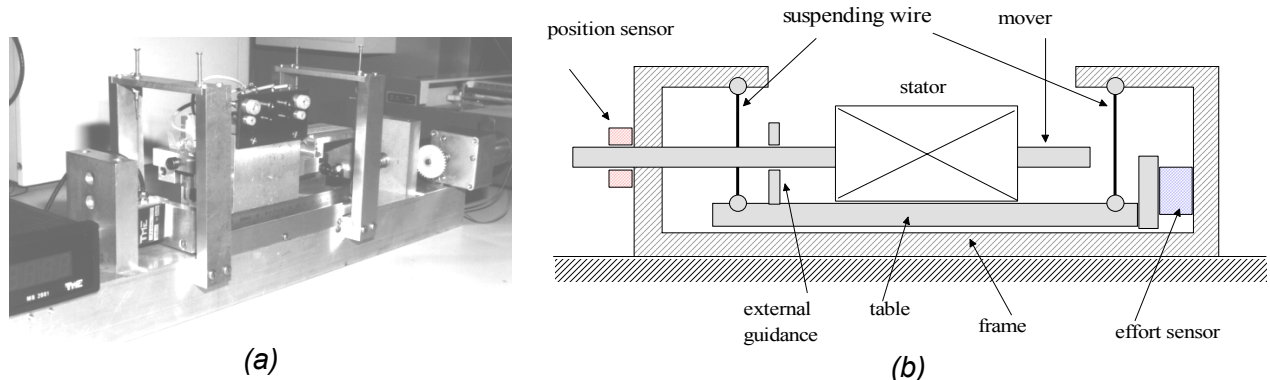

Figure 23: Linear actuator test set-up

VII- CONCLUSION

In this paper on linear actuators, examples have been presented in response to various unique design-related constraints: minimizing cost, ease of manufacturing, high thrust, etc. Although the investigation carried out herein has not necessarily been exhaustive, it has nonetheless demonstrated the wide diversity of potential topologies.

It is fundamental to note that the major problem in developing linear actuators remains the effectiveness of the linear guidance aspect. The characterization of such an actuator however requires designing and building a specific testing apparatus (for measuring the instantaneous stress without rubbing, over a limited displacement, etc.).

VIII- REFERENCES

- [1] Multon B., « De nouvelles possibilités avec les moteurs à alimentation électronique dans les applications de grande diffusion », RGE janvier 1994, pp : 11-19.
- [2] The magnetic actuator technical commit of IEEJ, ed. « Linear motor and their applications », IEE of Japan, 1987, pp. : 6-14.
- [3] Ebihara D., Watada M., Oishi Y., « Structural Analysis of Linear Oscillatory Actuator », SPEEDAM Taormina, Italy, june 1994.
- [4] Iwabuchi N., Kawahara A., Kume T., Kabashima T., Nagasaka N., « A Novel High-Torque Reluctance Motor With Rare-Earth Magnet », IEEE Trans. on industry applications, vol. 30, N° 3, may/June 1994, pp. : 609-613.
- [5] York M., Stephensen J.M., Hughes A., « A Novel Electronically-Operated Linear Variable-Reluctance Actuator », EPE'97, Trondheim, proceeding vol. III, pp. : 892-897.

- [6] Wakiwaka H., Senoh S., Yajima H., Yamada H. « Smoother Thrust on Multi-polar Type Linear DC Motor », IEEE trans. on magnetics, vol. 33, N°5, September 1997, pp. : 3877-3879.
- [7] Yajima H., Wakiwaka H., Senoh S. « Consideration on High-Response of Linear DC Motor », IEEE trans. on magnetics, vol. 33, N°5, September 1997, pp. : 3877-3879.
- [8] Hörmann O., « Linear Direct Drives : Dynamic, Economics, Innovative », Intelligent Motion, June 1993 proceedings. pp. : 82-87.
- [9] Staton D.A., Deodhar R.P., Soong W.L., Miller T.J.E. « Torque prediction using the flux-mmF diagram in AC, DC and reluctance motors ». Proceedings IEEE trans. on Ind. Appl., vol. 32, Jan./Feb. 1996, pp. : 180-188.
- [10] Llibre J.F., Matt D., « Vernier reluctance magnet machine for electric vehicle », ICEM'94, Paris (France), Vol. 1, september 1994, pp : 251-256.
- [11] Lawrenson P.J., Stephenson J.M., Blenkinsop P.T., Corda J., Fulton N.N. « Variable-Speed Switched Reluctance Motors ». Proceedings IEE, Vol. 127, Pt. B, No. 4, July 1980, pp. : 253-265.
- [12] Block R., Henneberger G. « Numerical calculation and simulation of a claw-pole alternator ». Proceedings of Int. Conf. On Elec. Machines, Vol. 1, Manchester UK, Sep. 1992, pp. : 127-131.
- [13] Ben Ahmed H., Desesquelles P.F., Lucidarme J., « numerical Method Designing of PM and Global Coil Machines », Journal de Physique III, october 1995, pp : 703-725 (in French).
- [14] Rioux C., Guillet R., Roche J., Lucidarme J., Pouillange J. « Moteur électrique polyphasé à réductance variable », European Patent CNRS N° EP 0 2 218 521 A1, April 1987.
- [15] Lucidarme J., Multon B., Prévond L., « Actionneurs hybrides monophasés à commutation de flux », French Patent CNRS, N° F94-12063, October 1994.
- [16] Prévond L., Lucidarme J., Multon B., « Low cost flux switching linear hybrid actuator », ICEM proc. Vol. II, pp. : 317-322, September 1994.
- [17] Ben Ahmed H., Aufavre E., Multon B., « Designing of Single-Phase PM High Speed Machine », Journal de Physique III, October 1997, pp : 2031-2058 (in French).
- [18] Soulard J., Multon B., Lucidarme J., Lecrivain M., Prévond L., « Modelling, Analysis of Parameters and Tests of a Small Electronically Commutated Single-Phase Permanent Magnet Reluctance Motor », ICEM '96, Vigo, Spain, proceeding vol. II, PP. :45-50.
- [19] Lucidarme J., Amouri A., Poloujadoff M., «Optimum design of longitudinal field variable reluctance motors», IEEE trans. on Energy Conversion, vol. 8, n°3, September 1993, pp. : 357-361.
- [20] Amiet M., Lucidarme J. « Accélérateur ou actionneur linéaire », French Patent French Government, N° 95 15703, December 1995.