

Non-standard couples of angles of rotations

Mostapha Benhenda*

February 10, 2012

Abstract

Let M be a smooth compact connected manifold, on which there exists an effective smooth circle action S_t preserving a positive smooth volume. We show that on M , the smooth closure of the smooth volume-preserving conjugation class of some Liouville rotations S_α of angle α contains a smooth volume-preserving diffeomorphism T that is metrically isomorphic to an irrational rotation R_β on the circle, with $\alpha \neq \pm\beta$, and with α and β chosen either rationally dependent or rationally independent. In particular, if M is the closed annulus $[0, 1] \times \mathbb{T}^1$, M admits a smooth ergodic pseudo-rotation T of angle α that is metrically isomorphic to the rotation R_β . Moreover, T is smoothly tangent to S_α on the boundary of M .

1 Introduction

Let $A = [0, 1] \times \mathbb{T}^1$ be the closed annulus and T be a homeomorphism isotopic to the identity. The *rotation set* of T measures the asymptotic speeds of rotation of the orbits of T around the annulus. It generalizes the notion of rotation number of a circle homeomorphism, introduced by Poincaré. T is an *irrational pseudo-rotation* if its rotation set is reduced to a single irrational number α , called the *angle* of T . A broad question is raised by Béguin et al. [3]: what are the similarities between the dynamics of the rigid rotation S_α of angle α and the dynamics of an irrational pseudo-rotation T of angle α ?

From a topological viewpoint, a similarity between S_α and T has been shown by Béguin et al. [3]: the rotation S_α is in the closure of the conjugacy class of T . Their result is analogous to a theorem by Kwapisz [11] on the torus \mathbb{T}^2 (in this case, the angle of a pseudo-rotation is an element of \mathbb{T}^2). Jäger [9] and Wang [12] also investigated this broad question. However, there are also possible differences between S_α and T . From a metric viewpoint, Anosov and Katok [1] constructed a smooth pseudo-rotation of A that is metrically isomorphic to an ergodic translation of \mathbb{T}^2 . Béguin et al. [2] constructed on \mathbb{T}^2 a pseudo-rotation that is minimal, uniquely ergodic, but with positive entropy. In this paper, we construct a smooth pseudo-rotation of angle α that is metrically isomorphic to an irrational rotation R_β with $\alpha \neq \pm\beta$. This is a construction of a non-standard smooth realization, based on the method of approximation by successive conjugations (see [5] for a presentation), a method that is often fruitful in smooth realization problems.

*Laboratoire d'Analyse, Géométrie et Applications, Paris 13 University, 99 Avenue J.B. Clément, 93430 Villetaneuse, France. Part of this work was accomplished during the TEMPUS Summer School on dynamical systems held at the PMF University of Tuzla, Bosnia and Herzegovina. I would like to thank Elvis Barakovic and Dino Bojadzija for hospitality in Tuzla, and Muharem Avdispahic, Huse Fatkic, Senada Kalabusic and Amil Pecenkovic for hospitality in Sarajevo. Contact: mostaphabenhenda@gmail.com

We recall that a *smooth realization* of an abstract system (X, f, ν) is a triplet (M, T, μ) , where M is a smooth compact manifold, μ a smooth measure on M and T a smooth μ -preserving diffeomorphism of M , such that (M, T, μ) is metrically isomorphic to (X, f, ν) (when (M, μ) and (X, ν) are implied, we just say that T is metrically isomorphic to f). Moreover, a smooth realization is *non-standard* if M and X are not diffeomorphic.

Suppose there exists an ergodic pseudo-rotation T of angle α that is a non-standard smooth realization of a rotation R_β on the circle. Then the couple (α, β) is called a *non-standard couple of angles*. In this paper, we show that there exists non-standard couple of angles (α, β) , such that $\alpha \neq \pm\beta$, with α and β chosen either rationally dependent or rationally independent.

Anosov and Katok [1] showed the existence of an angle α such that (α, α) is a non-standard couple of angles. Fayad et al. [7] showed that for any α Liouville, (α, α) is a non-standard couple of angles. The question arises about the existence of a non-standard couple of angles (α, β) with $\alpha \neq \beta$.

It is worthy to recall that two ergodic rotations R_α and R_β on the circle are metrically isomorphic if and only if $\beta = \pm\alpha$. If $\beta = \alpha$, the isomorphism is the identity, and if $\beta = -\alpha$, an isomorphism is given by a symmetry of axis going through the center of the circle. Therefore, by applying the result of Fayad et al. [7], it becomes trivial to find a non-standard couple of angles $(\alpha, -\alpha)$. Our result shows that if, instead of considering metric automorphisms of the circle, we consider metric isomorphisms between the circle and the annulus, the situation becomes richer: we can have $\alpha \neq \pm\beta$, with α and β either rationally dependent or rationally independent. However, α needs to be Liouville. Indeed, a result by Herman (with a proof published by Fayad and Krikorian [6]) implies that if a smooth quasi-rotation T of the closed annulus has Diophantine angle (i.e. non-Liouville), then T cannot be ergodic (and a fortiori, T cannot be metrically isomorphic to an ergodic rotation). However, the situation where α is Liouville and β is Diophantine, though not addressed in this paper, is not excluded yet. The existence of this situation would reply positively to the open question about the existence of a non-standard smooth realization of a Diophantine circle rotation [5].

More generally, let M be a smooth compact connected manifold of dimension d , on which there exists an effective smooth circle action S_t preserving a positive smooth measure μ . Let \mathcal{A}_α be the smooth conjugation class of the rotation S_α , and $\bar{\mathcal{A}}_\alpha$ its closure in the smooth topology. If $M = \mathbb{T}^1$ and if α is Diophantine, then $\bar{\mathcal{A}}_\alpha = \mathcal{A}_\alpha$ by Herman-Yoccoz theorem [14] (indeed, by continuity, the rotation number of a diffeomorphism $T \in \bar{\mathcal{A}}_\alpha$ is α). On the other hand, when α is Liouville, $\bar{\mathcal{A}}_\alpha \neq \mathcal{A}_\alpha$. In this paper, if M has a dimension $d \geq 2$, then for some Liouville α , we show that $\bar{\mathcal{A}}_\alpha$ contains non-standard smooth realizations of circle rotations R_β , with $\alpha \neq \pm\beta$, and with α and β chosen either rationally dependent or rationally independent. In this case, (α, β) is still called a *non-standard couple of angles*. More precisely, we show the following theorem:

Theorem 1.1. *Let M be a smooth compact connected manifold of dimension $d \geq 2$, on which there exists an effective smooth circle action $(S_t)_{t \in \mathbb{T}^1}$ preserving a positive smooth measure μ . For any $u, v \in \mathbb{T}^1$, for any $\epsilon > 0$, there exist $(\alpha, \beta) \in \mathbb{T}^1 \times \mathbb{T}^1$ in a ϵ -neighborhood of (u, v) , $T \in \text{Diff}^\infty(M, \mu)$, such that $T \in \bar{\mathcal{A}}_\alpha$ and such that the rotation R_β of angle β on \mathbb{T}^1 is metrically isomorphic to T . Moreover, β can be chosen either rationally dependent or rationally independent of α .*

Theorem 1.1 generalizes the particular case $M = [0, 1]^{d-1} \times \mathbb{T}^1$:

Theorem 1.2. *Let $d \geq 2$, $M = [0, 1]^{d-1} \times \mathbb{T}^1$, μ the Lebesgue measure. For $t \in \mathbb{T}^1$, let $S_t : M \rightarrow M$ defined by $S_t(x, s) = (x, s + t)$. For any $u, v \in \mathbb{T}^1$, for any $\epsilon > 0$, there exist $(\alpha, \beta) \in \mathbb{T}^1 \times \mathbb{T}^1$ in a ϵ -neighborhood of (u, v) , $T \in \text{Diff}^\infty(M, \mu)$, such that for any $j \in \mathbb{N}$, $(D^j T)|_{\partial M} = (D^j S_\alpha)|_{\partial M}$ and such that the rotation R_β of angle β on \mathbb{T}^1 is metrically isomorphic to T . Moreover, β can be chosen either rationally dependent or rationally independent of α .*

In the case of the closed annulus $M = [0, 1] \times \mathbb{T}^1$, we obtain:

Corollary 1.3. *Let $M = [0, 1] \times \mathbb{T}^1$, μ the Lebesgue measure. For $t \in \mathbb{T}^1$, let $S_t : M \rightarrow M$ defined by $S_t(x, s) = (x, s + t)$. For any $u, v \in \mathbb{T}^1$, for any $\epsilon > 0$, there exist $(\alpha, \beta) \in \mathbb{T}^1 \times \mathbb{T}^1$ in a ϵ -neighborhood of (u, v) , $T \in \text{Diff}^\infty(M, \mu)$ a pseudo-rotation of angle α , such that the rotation R_β of angle β on \mathbb{T}^1 is metrically isomorphic to T . Moreover, β can be chosen either rationally dependent or rationally independent of α .*

To show these results, we suitably modify one of Anosov and Katok's constructions. In [1], they constructed ergodic translations on the torus \mathbb{T}^h , $h \geq 2$, of coordinates $(\beta_1, \dots, \beta_h)$, translations that admit non-standard smooth realizations on $[0, 1]^{d-1} \times \mathbb{T}^1$, $d \geq 2$, such that $T|_{\partial M}$ is a rotation of angle α . Moreover, in his construction, $\alpha \neq \beta_i$, $i = 1, \dots, h$. In our paper [4], we show that one β_i can be an arbitrarily chosen Liouville number. However, this construction does not apply directly to the one-dimensional case. This is why, to obtain our result, though we essentially follow [4], we still need some substantial modifications.

1.1 Definitions

Let $\text{Diff}^\infty(M, \mu)$ be the class of smooth diffeomorphisms of M preserving the Lebesgue measure μ . For $B \in \text{Diff}^\infty(M, \mu)$ and $j \in \mathbb{N}^*$, let $D^j B$ be the j^{th} derivative of B if $j > 0$, and the $-j^{\text{th}}$ derivative of B^{-1} if $j < 0$. For $x \in M$, let $|D^j B(x)|$ be the norm of $D^j B(x)$ at x . We denote $\|B\|_k = \max_{0 < |j| \leq k} \max_{x \in M} |D^j B(x)|$.

A finite measurable partition $\tilde{\xi}$ of a measured manifold (N, ν) is the equivalence class of a finite set ξ of disjoint measurable subsets of N whose union is N , modulo sets of ν -measure zero. In most of this paper, we do not distinguish a partition ξ with its equivalent class $\tilde{\xi}$ modulo sets of ν -measure zero. In these cases, both are denoted ξ . Moreover, all partitions considered in this paper are representatives of a finite measurable partition. The distance between two finite measurable partitions ξ and ξ' is defined by:

$$d(\xi, \xi') = \inf \sum_{c \in \xi, c' \in \xi'} \nu(c \Delta c')$$

A partition ξ' is *subordinate* to a partition ξ if any element of ξ is a union of elements of ξ' , modulo sets of ν -measure zero. In this case, if $\mathcal{B}(\xi)$ denotes the completed algebra generated by ξ , then $\mathcal{B}(\xi) \subset \mathcal{B}(\xi')$. The inclusion map $i : \mathcal{B}(\xi) \rightarrow \mathcal{B}(\xi')$ will be denoted $\xi \hookrightarrow \xi'$. This notation also means that ξ' is *subordinate* to ξ . A sequence of partitions ξ_n is *monotonic* if for any n , $\xi_n \hookrightarrow \xi_{n+1}$. These definitions and properties are independent of the choice of the representatives ξ and ξ' of the equivalence classes $\tilde{\xi}$ and $\tilde{\xi}'$.

A measure-preserving bijective bimeasurable map $T : (M_1, \mu_1, \mathcal{B}_1) \rightarrow (M_2, \mu_2, \mathcal{B}_2)$ induces an *isomorphism* of measure algebras, still denoted $T : (\mu_1, \mathcal{B}_1) \rightarrow (\mu_2, \mathcal{B}_2)$. If ξ_1, ξ_2 are partitions, and if $\mathcal{B}_1 = \mathcal{B}(\xi_1)$ and $\mathcal{B}_2 = \mathcal{B}(\xi_2)$, we denote $T : \xi_1 \rightarrow \xi_2$ this induced isomorphism of measure algebras. If $M_1 = M_2$, $\mu_1 = \mu_2$ and $\mathcal{B}_1 = \mathcal{B}_2$, then T

is a *measure-preserving transformation*. Its induced isomorphism is an *automorphism* (see [8, p.43] and [13]).

A *metric isomorphism* L of measure-preserving transformations $T_1 : (M_1, \mu_1, \mathcal{B}_1) \rightarrow (M_1, \mu_1, \mathcal{B}_1)$, $T_2 : (M_2, \mu_2, \mathcal{B}_2) \rightarrow (M_2, \mu_2, \mathcal{B}_2)$ is a measure-preserving bijective bimeasurable map $L : (M_1, \mu_1, \mathcal{B}_1) \rightarrow (M_2, \mu_2, \mathcal{B}_2)$ such that $LT_1 = T_2L$ a.e. For convenience, when the measure is the Lebesgue measure and the algebra is the Borelian algebra, we omit to mention the measures and algebras, and we simply say that $L : (M_1, T_1) \rightarrow (M_2, T_2)$ is a metric isomorphism.

Let $\tilde{\xi}$ be a measurable partition and ξ a representative of this equivalent class modulo sets of μ -measure zero. For $x \in M$, we denote $\xi(x)$ the element of the partition ξ such that $x \in \xi(x)$. A sequence of partitions ξ_n of measurable sets *generates* if there is a set of full measure F such that for any $x \in F$,

$$\{x\} = F \bigcap_{n \geq 1} \xi_n(x)$$

This property of generation is independent of the choice of the representatives ξ_n of the equivalent class $\tilde{\xi}_n$ and therefore, we will say that the sequence of measurable partitions $\tilde{\xi}_n$ generates. Let M/ξ denote the equivalent class of the algebra generated by ξ , modulo sets of μ -measure zero. M/ξ is independent of the choice of the representative ξ of the equivalent class $\tilde{\xi}$. If $T : M_1 \rightarrow M_2$ is a measure-preserving map such that $T(\xi_1) = \xi_2$ μ -almost everywhere, we can define a quotient map: $T/\xi_1 : M/\xi_1 \rightarrow M/\xi_2$.

An *effective action* of a group G on M is an action such that there is a set of full measure $F \subset M$ such that for any $x \in F$, there is $g \in G$ such that $gx \neq x$. A smooth effective circle action $(S_t)_{t \in \mathbb{T}^1}$ on M can be seen as a 1-periodic smooth flow $(S_t)_{t \geq 0}$, we denote $\mathcal{A}_\alpha = \{B^{-1}S_\alpha B, B \in \text{Diff}^\infty(M, \mu)\}$. When $M = [0, 1]^{d-1} \times \mathbb{T}^1$, we consider the periodic flow S_t defined by:

$$\begin{aligned} S_t : [0, 1]^{d-1} \times \mathbb{T}^1 &\rightarrow [0, 1]^{d-1} \times \mathbb{T}^1 \\ (x, s) &\mapsto (x, t + s \pmod{1}) \end{aligned}$$

For $a, b \in \mathbb{T}^1$, let $[a, b]$ be the positively oriented circular sector between a and b , with a included and b excluded.

A sequence T_n of μ -preserving maps *weakly converges* to T if, for any measurable set E , $\mu(T_n E \Delta E) \rightarrow 0$, where $A \Delta B = (A - B) \cup (B - A)$.

For $\gamma \in \mathbb{R}$, we denote: $|\gamma|_{\text{mod } 1} = \min_{k \in \mathbb{Z}} |k + \gamma|$

For $t \in \mathbb{T}^1$ or \mathbb{R} , and $A \subset I \times \mathbb{T}^1$, we denote

$$t + A = \{(x, t + s \pmod{1}), (x, s) \in A\}$$

Suppose $M = [0, 1] \times \mathbb{T}^1$ is the closed annulus. Let $\tilde{M} = [0, 1] \times \mathbb{R}$ be the universal covering of M and $p_2 : [0, 1] \times \mathbb{R} \rightarrow \mathbb{R}$ the second coordinate projection. Let T be a homeomorphism of M isotopic to the identity and \tilde{T} its lift to \tilde{M} . The *rotation set* $\text{Rot}(\tilde{T})$ of \tilde{T} is defined by:

$$\text{Rot}(\tilde{T}) = \bigcap_{k \geq 0} \bigcup_{n \geq k} \left\{ \frac{p_2(\tilde{T}(\tilde{x})) - p_2(\tilde{x})}{n} / \tilde{x} \in \tilde{M} \right\}$$

We let the rotation set of T , $\text{Rot}(T)$, be the equivalent class modulo 1 of $\text{Rot}(\tilde{T})$. If $\text{Rot}(T) = \{\alpha\}$ is a singleton, and if T is isotopic to the identity, then T is a *pseudo-rotation*. Note that, if $T|_{\partial M} = S_{\alpha|_{\partial M}}$, then T is isotopic to the identity. Indeed,

$t \in [0, 1] \mapsto S_{t\alpha}$ is a continuous path between the identity map and S_α , and by Alexander's trick, any homeomorphism equal to the identity on the boundary is isotopic to the identity. In this paper, all the diffeomorphisms that we construct are equal to a rotation on the boundary and therefore, they are all isotopic to the identity.

1.2 Basic steps of the proof

The metric isomorphism of theorem 1.2 is obtained as the limit of isomorphisms of finite algebras: indeed, we use the lemma [1, p.18]:

Lemma 1.4. *Let M_1 and M_2 be Lebesgue spaces and let $\xi_n^{(i)}$ ($i = 1, 2$) be monotonic and generating sequences of finite measurable partitions of M_i . Let $T_n^{(i)}$ be automorphisms of M_i such that $T_n^{(i)} \xi_n^{(i)} = \xi_n^{(i)}$ and $T_n^{(i)} \rightarrow T^{(i)}$ in the weak topology. Suppose there are metric isomorphisms $L_n : M_1/\xi_n^{(1)} \rightarrow M_2/\xi_n^{(2)}$ such that*

$$L_n T_n^{(1)} / \xi_n^{(1)} = T_n^{(2)} / \xi_n^{(2)} L_n$$

and

$$L_{n+1} \xi_n^{(1)} = \xi_n^{(2)}$$

then (M_1, T_1) and (M_2, T_2) are metrically isomorphic.

Said otherwise, if we have generating sequences of partitions and sequences of automorphisms $T_n^{(i)}$ weakly converging towards $T^{(i)}$, and if, for any integer n , the following diagram commutes:

$$\begin{array}{ccc} T_n^{(1)} \left(\xi_n^{(1)} \right) & \xrightarrow{L_n} & \xi_n^{(2)} \left(T_n^{(2)} \right) \\ \downarrow & & \downarrow \\ T_{n+1}^{(1)} \left(\xi_{n+1}^{(1)} \right) & \xrightarrow{L_{n+1}} & \xi_{n+1}^{(2)} \left(T_{n+1}^{(2)} \right) \end{array}$$

then (M_1, T_1) and (M_2, T_2) are metrically isomorphic.

The proof of theorem 1.2 is in two steps. In the first step (lemma 1.5), we determine sufficient conditions on a sequence $(R_{\frac{p_n}{q_n}})_{n \geq 0}$ of periodic rotations of \mathbb{T}^1 such that there exists sequences of finite partitions and automorphisms satisfying the assumptions of lemma 1.4 with $M_1 = \mathbb{T}^1$, $M_2 = M$, $T_n^{(1)} = R_{\frac{p_n}{q_n}}$, $T_n^{(2)} = T_n$, where T_n is also smooth diffeomorphism, and such that the limit T in the smooth topology of the sequence T_n is smooth, and $T \in \bar{\mathcal{A}}_\alpha$ for $\alpha = \lim p_n/q_n$.

In the second step (lemma 1.6), we construct sequences of integers satisfying the conditions of the first step, such that $p_n/q_n \rightarrow \alpha$, $b_n p_n/q_n \rightarrow \beta$, with (α, β) that can be chosen arbitrarily close to any $(u, v) \in \mathbb{T}^1 \times \mathbb{T}^1$, and with (α, β) either rationally dependent or rationally independent.

Lemma 1.5. *There exists an explicit sequence of integers $R_1(n) \geq n$, such that, if there exist increasing sequences of integers $p_n, q_n, a_n, b_n \in \mathbb{N}^*$, and a sequence $s_n \in \mathbb{Z}^*$ such that, for any integer n ,*

1. (primality) $a_n b_n - s_n q_n = 1$.
2. (monotonicity) q_n divides q_{n+1} and $q_n < q_{n+1}$.

3. (isomorphism) q_n divides $a_{n+1} - a_n$.

4. (convergence of the diffeomorphism, generation)

$$0 < \left| \frac{p_{n+1}}{q_{n+1}} - \frac{p_n}{q_n} \right| \leq \frac{1}{(b_{n+1}q_n)^{R_1(n)}}$$

then all these assumptions imply that there are $\alpha, \beta \in \mathbb{T}^1$ such that

$$\frac{p_n}{q_n} \rightarrow^{mod 1} \alpha, \quad \frac{p_n}{q_n} b_n \rightarrow^{mod 1} \beta$$

and there is a smooth ergodic measure-preserving diffeomorphism T of M such that for any $j \in \mathbb{N}$, $(D^j T)_{\partial M} = (D^j S_\alpha)_{\partial M}$ and such that $(\mathbb{T}^1, R_\beta, Leb)$ is metrically isomorphic to (M, T, μ) .

Lemma 1.6. For any $u, v \in \mathbb{T}^1$, for any $\epsilon > 0$, there exist $(\alpha, \beta) \in \mathbb{T}^1 \times \mathbb{T}^1$ in a ϵ -neighborhood of (u, v) , such that there exist sequences of integers $p_n, q_n, a_n, b_n \in \mathbb{N}^*$, $s_n \in \mathbb{Z}^*$ satisfying the assumptions of lemma 1.5, such that

$$\frac{p_n}{q_n} \rightarrow^{mod 1} \alpha, \quad \frac{p_n}{q_n} b_n \rightarrow^{mod 1} \beta$$

Moreover, β can be chosen either rationally dependent of α or rationally independent of α .

We divide the proof of lemma 1.5 in two main parts. In the first part of the proof, we elaborate sufficient conditions on $B_n \in \text{Diff}^\infty(M, \mu)$, where $M = [0, 1]^{d-1} \times \mathbb{T}^1$, so that if $T_n = B_n^{-1} S_{\frac{p_n}{q_n}} B_n$ weakly converges towards an automorphism T , then there exists a metric isomorphism between $(\mathbb{T}^1, R_\beta, Leb)$ and (M, T, μ) . To that end, we apply lemma 1.4: we construct a monotonous and generating sequence of partitions ξ_n^∞ of M and a sequence of isomorphisms $\bar{K}_n^\infty : \mathbb{T}^1 / \zeta_n \rightarrow M / \xi_n^\infty$, where $\zeta_n = \{[i/q_n, (i+1)/q_n[, i = 0, \dots, q_n - 1\}$, such that $\bar{K}_n^\infty R_{\frac{p_n}{q_n}} = T_n \bar{K}_n^\infty$ and $\bar{K}_{n+1|_{\zeta_n}}^\infty = \bar{K}_n^\infty$. In the construction of this isomorphism, assumption 3 is important. Moreover, we will see that the elements of ξ_n^∞ are not the most elementary, because they must be chosen in a way that ensures the monotonicity of the sequence \bar{K}_n^∞ . This condition of monotonicity induces combinatorial constraints on the elements of the partition ξ_n^∞ . Though it follows a similar scheme, the construction of the sequence \bar{K}_n^∞ differs from [4], especially because the assumption 1 is new.

In the second part of the proof, we construct diffeomorphisms $T_n = B_n^{-1} S_{\frac{p_n}{q_n}} B_n$ on M stabilizing ξ_n^∞ , obtained by successive conjugations from the rotation $S_{\frac{p_n}{q_n}}$. The conjugacy B_n is constructed explicitly. In this second part, we essentially follow [4] (which elaborated on [7]), except for the obtention of the generation of the sequence of partitions $(\xi_n^\infty)_{n \geq 1}$, for which we need to slightly modify the construction.

Another change with respect to [4] is in the construction of the limit angles α and β , i.e. in the proof of lemma 1.6.

1.3 Construction of the limit angles α and β : proof of lemma 1.6.

1.3.1 The case $\beta = p\alpha$

Let $u, v \in \mathbb{T}^1$ and $\epsilon > 0$. Let p_0, q_0, b_0 be positive integers such that $\text{gcd}(b_0, q_0) = 1$, and such that:

$$\left| \frac{p_0}{q_0} - u \right|_{\text{mod } 1} \leq \frac{\epsilon}{2}, \quad \left| \frac{p_0 b_0}{q_0} - v \right|_{\text{mod } 1} \leq \frac{\epsilon}{2}$$

By the Bezout theorem, there are integers a_0, s_0 , with $a_0 > 0$, such that $a_0 b_0 - s_0 q_0 = 1$.

Suppose we have defined p_k, q_k, a_k, b_k, s_k , satisfying the assumptions of lemma 1.5, up to the rank $k = n$, and let us define $p_{n+1}, q_{n+1}, a_{n+1}, b_{n+1}, s_{n+1}$. (we will have $s_n = 1$ for $n \geq 1$). Let $b_{n+1} = b_n$.

Let c_n be an integer sufficiently large so that $c_n \geq (b_{n+1} q_n)^{R_1(n)}$ and $c_n \geq b_{n+1} 2^{n+1} / \epsilon$ ($b_n = b_0$ is constant here, but this more general definition is used for the case (α, β) rationally independent). Let

$$a_{n+1} = a_n + s_n c_n q_n$$

Therefore, assumption 3 holds. Let also

$$q_{n+1} = q_n s_n (1 + c_n b_n)$$

Therefore, assumption 2 holds. Moreover, we have:

$$a_{n+1} b_{n+1} - q_{n+1} = 1$$

Therefore, assumption 1 holds, with $s_{n+1} = 1$. Moreover, let $p_{n+1} = p_n \frac{q_{n+1}}{q_n} + 1$. Since $q_{n+1} \geq (b_{n+1} q_n)^{R_1(n)}$, we have:

$$0 < \left| \frac{p_{n+1}}{q_{n+1}} - \frac{p_n}{q_n} \right| = \frac{1}{q_{n+1}} \leq \frac{1}{(b_{n+1} q_n)^{R_1(n)}}$$

Therefore, assumption 4 holds. Moreover,

$$\frac{p_n}{q_n} b_n = \frac{p_0}{q_0} b_0 + \sum_{k=0}^{n-1} \left(\frac{p_{k+1}}{q_{k+1}} b_{k+1} - \frac{p_k}{q_k} b_k \right) =_{\text{mod } 1} \frac{p_0}{q_0} b_0 + \sum_{k=0}^{n-1} \left(\frac{p_{k+1}}{q_{k+1}} - \frac{p_k}{q_k} \right) b_{k+1} = \frac{p_0}{q_0} b_0 + \sum_{k=0}^{n-1} \frac{b_{k+1}}{q_{k+1}}$$

Since $1/q_{n+1} \leq \epsilon / (2^{n+1} b_{n+1})$, we get:

$$\left| \frac{p_n}{q_n} b_n - \frac{p_0}{q_0} b_0 \right| \leq \frac{\epsilon}{2}$$

Therefore,

$$\frac{p_n}{q_n} b_n \rightarrow \beta$$

with $|\beta - u| \leq \epsilon$

Likewise,

$$\frac{p_n}{q_n} \rightarrow \alpha$$

with $|\alpha - v| \leq \epsilon$. Moreover, we have $\beta = b_0 \alpha$.

1.3.2 The case (α, β) rationally independent

The beginning of the construction is the same as in the case $\beta = p\alpha$, except that we take:

$$b_{n+1} = b_n + q_n$$

$$q_{n+1} = s_n q_n (1 + c_n b_n + c_n q_n + a_n)$$

This ensures that $b_n \rightarrow +\infty$ as $n \rightarrow +\infty$, and that

$$a_{n+1} b_{n+1} - q_{n+1} = 1$$

It only remains to show that the limit angles (α, β) are rationally independent. To that aim, it suffices to show that the translation of vector (α, β) on the torus \mathbb{T}^2 is ergodic. We follow the proof of the ergodicity of the limit translation in [4], with a slight modification. We recall a theorem by Katok and Stepin [10]:

Theorem 1.7 (Katok-Stepin [10]). *Let U be an automorphism of a Lebesgue space (N, ν) , let $(U_n)_{n \geq 1}$ be a sequence of measure-preserving transformations, and let $(\chi_n)_{n \geq 1}$ be a sequence of finite partitions of N with measurable elements. Suppose that:*

- U_n permutes the elements of χ_n cyclically.
- $(\chi_n)_{n \geq 1}$ generates.
- $\sum_{c \in \chi_n} \nu(U(c)\Delta U_n(c)) = o(1/|\chi_n|)$ (where $|\chi_n|$ is the cardinal of χ_n).

then U is ergodic.

Let $\gamma^{(n)} = (1, b_n)$, $g_n = \gcd(p_n, q_n)$. Let $\Gamma^{(n)} \subset \mathbb{T}^2$ a fundamental domain of the flow $(T^{t\gamma^{(n)}})_{t \geq 0}$ on \mathbb{T}^2 , where $T^{t\gamma^{(n)}}$ is the translation of vector $t\gamma^{(n)}$. Note that the diameter of $\Gamma^{(n)}$ is less than $1/b_n$. Let

$$\Gamma_{0,n} = \bigcup_{0 \leq t < \frac{g_n}{q_n}} T^{t\gamma^{(n)}} \Gamma^{(n)}$$

We have the lemma:

Lemma 1.8. *Let $\hat{\zeta}_n$ be the partition defined by:*

$$\hat{\zeta}_n = \left\{ \Gamma_{i,n} = T^{i \frac{g_n \gamma^{(n)}}{q_n}} \Gamma_{0,n}, i = 0, \dots, \frac{q_n}{g_n} - 1 \right\}$$

$T^{\frac{p_n}{q_n} \gamma^{(n)}}$ is a cyclic permutation on $\hat{\zeta}_n$, and $\hat{\zeta}_n$ generates.

Proof. $T^{\frac{p_n}{q_n} \gamma^{(n)}}$ is a cyclic permutation on $\hat{\zeta}_n$ because $g_n = \gcd(p_n, q_n)$.

To the vector space \mathbb{R}^2 , we give the norm $\|(x_1, x_2)\| = \max_{1 \leq i \leq 2} |x_i|$ and we consider its induced norm on \mathbb{T}^2 .

Since

$$p_{n+1} - \frac{q_{n+1}}{q_n} p_n = 1$$

then p_{n+1} and $\frac{q_{n+1}}{q_n}$ are relatively prime. Since g_{n+1} divides p_{n+1} and q_{n+1} , then g_{n+1} divides q_n . In particular, $g_{n+1} \leq q_n$ (this is the slight difference with the proof in [4]:

in [4], we do not have: $\gcd(p_{n+1}, \frac{q_{n+1}}{q_n}) = 1$. But on the other hand, in [4], we have: $\gcd(p_{n+1}, \frac{q_{n+1}}{q_n}) = \gcd(p_{n+1}, q_{n+1})$. The important point is that in both cases, g_n is small enough).

Moreover, by assumption 3 of lemma 1.5,

$$\frac{b_{n+1}q_n}{q_{n+1}} \leq \frac{1}{(b_{n+1}q_n)^{R_1(n)-1}} \rightarrow_{n \rightarrow +\infty} 0$$

Therefore,

$$\text{diam}(\Gamma_{0,n}) \leq \max\left(\frac{1}{b_n}, \frac{g_n \|\gamma^{(n)}\|}{q_n}\right) \leq \max\left(\frac{1}{b_n}, \frac{q_{n-1}b_n}{q_n}\right) \rightarrow_{n \rightarrow +\infty} 0$$

It shows that $\hat{\zeta}_n$ generates. \square

It remains to estimate $\sum_{c \in \hat{\zeta}_n} \mu_2(T^\alpha c \Delta T^{\frac{p_n}{q_n} \gamma^{(n)}} c)$, where μ_2 is the Lebesgue measure on \mathbb{T}^2 . We have the lemma:

Lemma 1.9. *We have:*

$$\sum_{c \in \hat{\zeta}_n} \mu_2(T^{(\alpha, \beta)} c \Delta T^{\frac{p_n}{q_n} \gamma^{(n)}} c) = o(g_n/q_n) = o(1/|\hat{\zeta}_n|)$$

Proof. We have:

$$\sum_{c \in \hat{\zeta}_n} \mu_2(T^{(\alpha, \beta)} c \Delta T^{\frac{p_n}{q_n} \gamma^{(n)}} c) = \sum_{k \geq n} \sum_{c \in \hat{\zeta}_k} \mu_2\left(T^{\frac{p_{k+1}}{q_{k+1}} \gamma^{(k+1)}} c \Delta T^{\frac{p_k}{q_k} \gamma^{(k)}} c\right) = \sum_{k \geq n} \sum_{c \in \hat{\zeta}_k} \mu_2\left(T^{\frac{p_{k+1}}{q_{k+1}} \gamma^{(k+1)} - \frac{p_k}{q_k} \gamma^{(k)}} c \Delta c\right)$$

Let τ_n be the $(h-1)$ -volume of the border of an element of $\hat{\zeta}_n$. We have:

$$\mu_2\left(T^{\frac{p_{k+1}}{q_{k+1}} \gamma^{(k+1)} - \frac{p_k}{q_k} \gamma^{(k)}} c \Delta c\right) \leq \tau_k \left\| \frac{p_{k+1}}{q_{k+1}} \gamma^{(k+1)} - \frac{p_k}{q_k} \gamma^{(k)} \right\| = \tau_k \left\| \left(\frac{p_{k+1}}{q_{k+1}} - \frac{p_k}{q_k} \right) \gamma^{(k+1)} \right\| = \tau_k \frac{b_{k+1}}{q_{k+1}}$$

Moreover,

$$\tau_n \leq 2 \left(\frac{1}{b_n} + \frac{g_n b_n}{q_n} \right) \leq 2 \left(\frac{1}{b_n} + \frac{q_{n-1} b_n}{q_n} \right)$$

Therefore,

$$\sum_{c \in \hat{\zeta}_n} \mu_2(T^{(\alpha, \beta)} c \Delta T^{\frac{p_n}{q_n} \gamma^{(n)}} c) = o(g_n/q_n)$$

\square

By combining lemmas 1.8 and 1.9, and by applying theorem 1.7, we obtain that the translation of vector (α, β) is ergodic with respect to the Lebesgue measure.

This completes the proof of lemma 1.6.

Let us make one remark. We were not able to show our theorem for any α Liouville, because conditions 1-3 of lemma 1.5 introduce arithmetical constraints on the denominators of the convergents of α . These conditions are analogous to those, in [4], which limit the set of possible translations of the h -dimensional torus, $h \geq 2$, that admit a non-standard smooth realization.

A sufficient condition for α Liouville to belong to a non-standard couple of angles (α, β) with $\alpha \neq \pm\beta$, is the following: if, for the sequence p'_n, q'_n of convergents of α , there exist positive integers c_n, d_n , with $d_n \leq q_n^{R(n)}$ for a fixed sequence $R(n)$, such that we can write:

$$q'_{n+1} = 1 + c_n b_n + d_n a_n + c_n d_n q_n$$

then there is $\beta \neq \pm\alpha$ such that (α, β) is a non-standard couple of angles. (in this construction, we take $b_{n+1} = b_n + d_n q_n$, with $d_n \in \mathbb{N}$)

The rest of the paper is dedicated to the proof of lemma 1.5. Part of lemma 1.5 is straightforward, namely, the convergence modulo 1 of $\frac{p_n}{q_n}$ and $\frac{p_n}{q_n} b_n$ towards α and β respectively:

Partial proof of lemma 1.5. By assumption 2, for $n \geq 2$, $q_n \geq 2$. By assumption 3, and since $R_1(n) \geq n$, p_n/q_n is Cauchy, and converges.

To show the convergence modulo 1 of $\frac{p_n}{q_n} b_n$, we note that assumptions 1 at ranks n and $n+1$, and assumption 3 at rank n imply that q_n divides $b_{n+1} - b_n$. Indeed, let us write $b_{n+1} = b_n + k$, with k integer, and let us show that q_n divides k . By the assumption 3 at rank n , $a_{n+1} = a_n + c_n q_n$, with c_n integer. Therefore,

$$1 + s_{n+1} q_{n+1} = a_{n+1} b_{n+1} = (a_n + c_n q_n)(b_n + k) = a_n b_n + a_n k + q_n(c_n b_n + c_n k)$$

Therefore,

$$q_n \left(s_{n+1} \frac{q_{n+1}}{q_n} - s_n - c_n b_n - c_n k \right) = a_n k$$

Thus, q_n divides $a_n k$. Since q_n is relatively prime with a_n , then q_n divides k . Therefore, $b_n/q_n = b_{n+1}/q_n \pmod{1}$. Therefore,

$$\left| \frac{p_{n+1} b_{n+1}}{q_{n+1}} - \frac{p_n b_n}{q_n} \right| \equiv_{\text{mod } 1} \left| \frac{p_{n+1}}{q_{n+1}} - \frac{p_n}{q_n} \right| |b_{n+1}| \leq \frac{1}{(b_{n+1} q_n)^{R_1(n)-1}}$$

Since for $n \geq 1$, $q_n \geq 2$ and $R_1(n) - 1 \geq n - 1$, then the sequence $\left(\frac{p_n b_n}{q_n} \pmod{1} \right)_{n \geq 1}$ is Cauchy, and converges. \square

To show lemma 1.5, it remains to show that there is a smooth ergodic measure-preserving diffeomorphism T of M such that $T \in \bar{\mathcal{A}}_\alpha$ and such that $(\mathbb{T}^1, R_\beta, Leb)$ is metrically isomorphic to (M, T, μ) .

2 The metric isomorphism

In this section, our aim is to elaborate sufficient conditions on $B_n \in \text{Diff}^\infty(M, \mu)$, where $M = [0, 1]^{d-1} \times \mathbb{T}^1$, so that if $T_n = B_n^{-1} S_{\frac{p_n}{q_n}} B_n$ weakly converges towards an automorphism T , then there exists a metric isomorphism between $(\mathbb{T}^1, R_\beta, Leb)$ and (M, T, μ) .

To that end, we use lemma 1.4: we construct a monotonous and generating sequence of partitions ξ_n^∞ of M and a sequence of isomorphisms $\bar{K}_n^\infty : \mathbb{T}^1/\zeta_n \rightarrow M/\xi_n^\infty$, where $\zeta_n = \{[i/q_n, (i+1)/q_n[, i = 0, \dots, q_n - 1\}$, such that $\bar{K}_n^\infty R_{\frac{p_n}{q_n}} = T_n \bar{K}_n^\infty$ and $\bar{K}_{n+1}^\infty|_{\zeta_n} = \bar{K}_n^\infty$.

ζ_n is a partition of \mathbb{T}^1 that is monotonic (because q_n divides q_{n+1}) and that generates (because $q_n \rightarrow +\infty$). Let $\eta_n = \{I \times [j/q_n, (j+1)/q_n[, j = 0, \dots, q_n - 1\}$. η_n is a monotonic partition of M .

The following lemma is straightforward, but important:

Lemma 2.1. *Let a_n and q_n two relatively prime integers, and let*

$$K_n : \begin{array}{ccc} \zeta_n & \rightarrow & \eta_n \\ \left[\frac{i}{q_n}, \frac{i+1}{q_n} \right[& \mapsto & I \times \left[\frac{ia_n}{q_n}, \frac{ia_n+1}{q_n} \right[\end{array}$$

K_n is a metric isomorphism such that $K_n R_{\frac{1}{q_n}} = S_{\frac{a_n}{q_n}} K_n$. In other words, the following diagram commutes:

$$R_{\frac{1}{q_n}} \begin{array}{c} \curvearrowright \\ \zeta_n \end{array} \xrightarrow{K_n} \begin{array}{c} \curvearrowright \\ \eta_n \end{array} S_{\frac{a_n}{q_n}}$$

This lemma is related with two basic observations: the first is that both $R_{\frac{1}{q_n}}$ and $S_{\frac{a_n}{q_n}}$ are isomorphic to cyclic permutations of $\{0, \dots, q_n - 1\}$ (this set is given the counting measure, i.e. $\mu(A) = \#A$); the second observation is that two cyclic permutations of the same order are always conjugated.

The following lemma combines lemma 2.1 with the facts that $\zeta_n \hookrightarrow \zeta_{n+1}$ and $\eta_n \hookrightarrow \eta_{n+1}$:

Lemma 2.2. *Let $a_n, a_{n+1}, q_n, q_{n+1} \in \mathbb{N}$ such that $\gcd(a_n, q_n) = \gcd(a_{n+1}, q_{n+1}) = 1$, such that q_n divides q_{n+1} and such that q_n divides $a_{n+1} - a_n$. There exists a partition $\eta_n^{n+1} \hookrightarrow \eta_{n+1}$ of M stable by $S_{\frac{a_n}{q_n}}$, and there exists a metric isomorphism $K_n^{n+1} : \zeta_n \rightarrow \eta_n^{n+1}$ such that $K_n^{n+1} = K_{n+1}|_{\zeta_n}$ and such that $K_n^{n+1} R_{\frac{1}{q_n}} = S_{\frac{a_n}{q_n}} K_n^{n+1}$. There exists also a metric isomorphism $C_n^{n+1} : \eta_n \rightarrow \eta_n^{n+1}$ such that $C_n^{n+1} S_{\frac{a_n}{q_n}} = S_{\frac{a_n}{q_n}} C_n^{n+1}$ and $K_n^{n+1} = C_n^{n+1} K_n$. Said otherwise, we have the following commutative diagram:*

$$\begin{array}{ccc} R_{\frac{1}{q_n}} \begin{array}{c} \curvearrowright \\ \zeta_n \end{array} \xrightarrow{K_n} \begin{array}{c} \curvearrowright \\ \eta_n \end{array} S_{\frac{a_n}{q_n}} & & \\ \downarrow Id & & \downarrow C_n^{n+1} \\ R_{\frac{1}{q_n}} \begin{array}{c} \curvearrowright \\ \zeta_n \end{array} \xrightarrow{K_n^{n+1}} \begin{array}{c} \curvearrowright \\ \eta_n^{n+1} \end{array} S_{\frac{a_n}{q_n}} & & \\ \downarrow & & \downarrow \\ R_{\frac{1}{q_{n+1}}} \begin{array}{c} \curvearrowright \\ \zeta_{n+1} \end{array} \xrightarrow{K_{n+1}} \begin{array}{c} \curvearrowright \\ \eta_{n+1} \end{array} S_{\frac{a_{n+1}}{q_{n+1}}} & & \end{array}$$

Proof. Since $\gcd(a_{n+1}, q_{n+1}) = 1$, then by lemma 2.1, K_{n+1} is an isomorphism. Moreover, since q_n divides q_{n+1} , then $\zeta_n \hookrightarrow \zeta_{n+1}$. Therefore, we can define the isomorphism $K_n^{n+1} = K_{n+1}|_{\zeta_n}$. Let $\eta_n^{n+1} = K_n^{n+1}(\zeta_n)$. We have $\eta_n^{n+1} \hookrightarrow \eta_{n+1}$.

It remains to show that $K_n^{n+1} R_{\frac{1}{q_n}} = S_{\frac{a_n}{q_n}} K_n^{n+1}$ (it automatically implies that η_n^{n+1} is stable by $S_{\frac{a_n}{q_n}}$, and that there is $C_n^{n+1} : \eta_n \rightarrow \eta_n^{n+1}$ such that $C_n^{n+1} S_{\frac{a_n}{q_n}} = S_{\frac{a_n}{q_n}} C_n^{n+1}$). Let $0 \leq i \leq q_n - 1$. We have:

$$K_n^{n+1} R_{\frac{1}{q_n}} \left(\left[\frac{i}{q_n}, \frac{i+1}{q_n} \right] \right) = K_{n+1} R_{\frac{1}{q_n}} \left(\bigcup_{k=0}^{\frac{q_{n+1}}{q_n} - 1} \left[\frac{i}{q_n} + \frac{k}{q_{n+1}}, \frac{i}{q_n} + \frac{k+1}{q_{n+1}} \right] \right)$$

$$\begin{aligned}
&= K_{n+1} \left(\bigcup_{k=0}^{\frac{q_{n+1}-1}{q_n}} \left[\frac{i+1}{q_n} + \frac{k}{q_{n+1}}, \frac{i+1}{q_n} + \frac{k+1}{q_{n+1}} \right] \right) = \bigcup_{k=0}^{\frac{q_{n+1}-1}{q_n}} K_{n+1} \left(\left[\frac{1+i}{q_n} + \frac{k}{q_{n+1}}, \frac{1+i}{q_n} + \frac{k+1}{q_{n+1}} \right] \right) \\
&= I \times \bigcup_{k=0}^{\frac{q_{n+1}-1}{q_n}} \left[\frac{a_{n+1}}{q_n} + \frac{a_{n+1}i}{q_n} + \frac{a_{n+1}k}{q_{n+1}}, \frac{a_{n+1}}{q_n} + \frac{a_{n+1}i}{q_n} + \frac{a_{n+1}k}{q_{n+1}} + \frac{1}{q_{n+1}} \right]
\end{aligned}$$

Since $a_{n+1}/q_n = a_n/q_n \pmod{1}$, we get:

$$K_n^{n+1} R_{\frac{1}{q_n}} \left(\left[\frac{i}{q_n}, \frac{i+1}{q_n} \right] \right) = I \times \bigcup_{k=0}^{\frac{q_{n+1}-1}{q_n}} \left[\frac{a_n}{q_n} + \frac{a_{n+1}i}{q_n} + \frac{a_{n+1}k}{q_{n+1}}, \frac{a_n}{q_n} + \frac{a_{n+1}i}{q_n} + \frac{a_{n+1}k}{q_{n+1}} + \frac{1}{q_{n+1}} \right]$$

Therefore,

$$\begin{aligned}
K_n^{n+1} R_{\frac{1}{q_n}} \left(\left[\frac{i}{q_n}, \frac{i+1}{q_n} \right] \right) &= \bigcup_{k=0}^{\frac{q_{n+1}-1}{q_n}} S_{\frac{a_n}{q_n}} \left(I \times \left[\frac{a_{n+1}i}{q_n} + \frac{a_{n+1}k}{q_{n+1}}, \frac{a_{n+1}i}{q_n} + \frac{a_{n+1}k}{q_{n+1}} + \frac{1}{q_{n+1}} \right] \right) \\
&= S_{\frac{a_n}{q_n}} \left(I \times \bigcup_{k=0}^{\frac{q_{n+1}-1}{q_n}} \left[\frac{a_{n+1}i}{q_n} + \frac{a_{n+1}k}{q_{n+1}}, \frac{a_{n+1}i}{q_n} + \frac{a_{n+1}k}{q_{n+1}} + \frac{1}{q_{n+1}} \right] \right) = S_{\frac{a_n}{q_n}} K_n^{n+1} \left(\left[\frac{i}{q_n}, \frac{i+1}{q_n} \right] \right)
\end{aligned}$$

□

Let us denote $R^{(n)} = K_n^{n+1} \left(\left[0, \frac{1}{q_n} \right] \right)$.

We also denote $R_{i,n}^{n+1} = S_{\frac{ia_n}{q_n}} R^{(n)}$, $i = 0, \dots, q_n - 1$. $R^{(n)}$ is a fundamental domain of $S_{\frac{a_n}{q_n}}$. Moreover, we have:

$$\begin{aligned}
C_n^{n+1} : \eta_n &\rightarrow \eta_n^{n+1} \\
\left[\frac{ia_n}{q_n}, \frac{ia_n+1}{q_n} \right] &\mapsto R_{i,n}^{n+1}, i = 0, \dots, q_n - 1
\end{aligned}$$

Note also that $C_n^{n+1} R_{\frac{a_n}{q_n}} = R_{\frac{a_n}{q_n}} C_n^{n+1}$. Moreover, by assumption 1 of lemma 1.5, $a_n b_n / q_n = 1/q_n \pmod{1}$. Therefore, we get:

$$C_n^{n+1} R_{\frac{1}{q_n}} = C_n^{n+1} R_{\frac{a_n b_n}{q_n}} = R_{\frac{a_n b_n}{q_n}} C_n^{n+1} = R_{\frac{1}{q_n}} C_n^{n+1}$$

By iterating lemma 2.2, we get a corollary that is important for the construction of the isomorphism:

Corollary 2.3. *For any $m > n$, there are partitions $\eta_n^m \hookrightarrow \eta_{n+1}^m$ of M such that η_n^m is stable by $S_{\frac{1}{q_n}}$ and there exists an isomorphism $K_n^m : \zeta_n \rightarrow \eta_n^m$ such that $K_n^m R_{\frac{1}{q_n}} = S_{\frac{a_n}{q_n}} K_n^m$ and $K_n^m = K_{n+1}^m|_{\eta_n^m}$.*

Said otherwise, the following diagram commutes:

$$\begin{array}{ccc}
R_{\frac{1}{q_n}} \curvearrowright \xi_n^m & \xrightarrow{K_n^m} & \eta_n^m \curvearrowright S_{\frac{a_n}{q_n}} \\
\downarrow & & \downarrow \\
R_{\frac{1}{q_{n+1}}} \curvearrowright \xi_{n+1}^m & \xrightarrow{K_{n+1}^m} & \eta_{n+1}^m \curvearrowright S_{\frac{a_{n+1}}{q_{n+1}}}
\end{array}$$

Proof. The proof is similar to the corollary 3.2 in [4]. □

For any n fixed, the sequence of partitions $(\eta_n^m)_{m \geq n}$ must converge when $m \rightarrow +\infty$, in order to obtain a full sequence of monotonic partitions. Moreover, the possible limit sequence (i.e. a possible η_n^∞) must generate. Indeed, these assumptions are required to apply lemma 1.4. However, we can check that none of these assumptions are satisfied, in general. Therefore, to obtain these assumptions, we pull back the partition η_n^m by a suitable smooth measure-preserving diffeomorphism B_m . The following lemma, already proved in [4], gives the conditions that B_m must satisfy:

Lemma 2.4 ([1],[4]). *Let $B_m \in \text{Diff}^\infty(M, \mu)$. Let $A_{m+1} = B_{m+1}B_m^{-1}$.*

1. *If $A_{m+1}S_{\frac{1}{q_m}} = S_{\frac{1}{q_m}}A_{m+1}$ and if*

$$\sum_{m \geq 0} q_m \mu(\Delta_{0, q_m} \Delta_{A_{m+1}}^{-1} R^{(m)}) < +\infty$$

then for any fixed n , when $m \rightarrow +\infty$, the sequence of partitions $\xi_n^m = B_m^{-1}\eta_n^m$ converges. We denote ξ_n^∞ the limit. The sequence ξ_n^∞ is monotonous and $T_n = B_n^{-1}S_{\frac{p_n}{q_n}}B_n$ stabilizes each ξ_n^∞ .

2. *If, moreover, the sequence $\xi_n = B_n^{-1}\eta_n$ generates, then so does ξ_n^∞ .*

C_m^{m+1} is not continuous in general, and A_{m+1} is its differentiable approximation. Lemma 2.4 is the reason why we need for M a manifold of dimension $d \geq 2$. Indeed, if we took $M = \mathbb{T}^1$, we could not find a diffeomorphism B_m satisfying the assumptions of this lemma, except for $a_n = 1$ or $a_n = q_n - 1$. The choice $a_n = 1$ gives that the rotation R_α on the circle is isomorphic to itself. The choice $a_n = q_n - 1$ gives that R_α is isomorphic to $R_{-\alpha}$. The existence of these two isomorphisms are consistent with the fact, mentioned in the introduction, that R_α and R_β are isomorphic, with α irrational, if and only if $\alpha = \pm\beta$.

By adding to lemma 2.4 the convergence of the sequence T_n , we obtain the required isomorphism:

Corollary 2.5. *If both conditions 1. and 2. of lemma 2.4 hold, and if $T_n = B_n^{-1}S_{\frac{p_n}{q_n}}B_n$ weakly converges towards an automorphism T , then $(\mathbb{T}^1, R_\beta, \text{Leb})$ and (M, T, μ) are metrically isomorphic.*

Proof. By corollary 2.3, $K_n^m R_{\frac{1}{q_n}} = S_{\frac{a_n}{q_n}} K_n^m$. By iteration,

$$K_n^m R_{\frac{b_n p_n}{q_n}} = S_{\frac{a_n b_n p_n}{q_n}} K_n^m$$

Since $a_n b_n / q_n = 1 / q_n \pmod{1}$, then

$$K_n^m R_{\frac{b_n p_n}{q_n}} = S_{\frac{p_n}{q_n}} K_n^m$$

Therefore, the following diagram commutes:

$$\begin{array}{ccccc}
& & S \frac{p_n}{q_n} & & \\
& & \curvearrowright & & \\
R \frac{b_n p_n}{q_n} & \curvearrowright & \zeta_n & \xrightarrow{K_n^m} & \eta_n^m & \xrightarrow{B_m^{-1}} & \xi_n^m & \curvearrowright & T_n \\
& \downarrow & \downarrow & & \downarrow & & \downarrow & & \\
R \frac{b_{n+1} p_{n+1}}{q_{n+1}} & \curvearrowright & \zeta_{n+1} & \xrightarrow{K_{n+1}^m} & \eta_{n+1}^m & \xrightarrow{B_{n+1}^{-1}} & \xi_{n+1}^m & \curvearrowright & T_{n+1} \\
& & & & S \frac{p_{n+1}}{q_{n+1}} & & & & \\
& & & & \curvearrowright & & & &
\end{array}$$

Let $\bar{K}_n^\infty : \zeta_n^\infty \rightarrow \xi_n^\infty$ defined by $\bar{K}_n^\infty = P_n^\infty B_n^{-1} K_n(Q_n^\infty)^{-1}$.

As in the proof of corollary 3.4 in [4], we can show that $\bar{K}_n^\infty R_{b_n \frac{p_n}{q_n}} = T_n \bar{K}_n^\infty$ and that $\bar{K}_{n+1}^\infty|_{\zeta_n} = \bar{K}_n^\infty$. This allows to apply lemma 1.4, which gives the required metric isomorphism. \square

Let us make one remark. We consider the isomorphism between $R_{\frac{b_n p_n}{q_n}}$ and

$T_n = B_n^{-1} S \frac{p_n}{q_n} B_n$, instead of the isomorphism between $R_{\frac{p_n}{q_n}}$ and $\check{T}_n = B_n^{-1} S \frac{a_n p_n}{q_n} B_n$ (which seems to be a more "natural" choice), because in the latter case, we are not able to show the convergence of \check{T}_n towards a smooth diffeomorphism \check{T} . Indeed, we have:

$$d_k(\check{T}_{n+1}, \check{T}_n) \leq \|B_{n+1}\|_k \left| \frac{p_{n+1} a_{n+1}}{q_{n+1}} - \frac{p_n a_n}{q_n} \right|_{\text{mod } 1} = \|B_{n+1}\|_k a_{n+1} \left| \frac{p_{n+1}}{q_{n+1}} - \frac{p_n}{q_n} \right| \quad (1)$$

In the next section, we show that $\|B_{n+1}\|_k \leq (b_{n+1} q_n)^{R_1(n)}$ for some fixed sequence $R_1(n)$ (and we are not able to improve this estimate). Estimate (1) becomes:

$$d_k(\check{T}_{n+1}, \check{T}_n) \leq a_{n+1} (b_{n+1} q_n)^{R_1(n)} \left| \frac{p_{n+1}}{q_{n+1}} - \frac{p_n}{q_n} \right|$$

Moreover, by assumption 1 of lemma 1.5, $a_{n+1} b_{n+1} \geq q_{n+1}$. Since $\left| \frac{p_{n+1}}{q_{n+1}} - \frac{p_n}{q_n} \right| \geq \frac{1}{q_{n+1}}$, estimate (1) does not allow to show that \check{T}_n is Cauchy. On the other hand, applying this reasoning to show the convergence of T_n will be successful.

In order to construct the diffeomorphism A_{n+1} with suitable estimates of its norm, we need to control the width of the connected components of $R^{(n)}$. A priori, $R^{(n)}$ consists of q_{n+1}/q_n "slices" of width $1/q_{n+1}$. However, this fact does not ensure the convergence of T_n , because it only implies that $\|B_{n+1}\|_j \leq (q_{n+1})^{R(n)}$ for some fixed sequence of integers $R(n)$. In order to apply the reasoning above successfully, we need a better estimate. The following lemma shows that "slices" of $R^{(n)}$ of width $1/q_{n+1}$ stack on each other, which gives b_{n+1} connected components to $R^{(n)}$, each having a width of order $1/(q_n b_{n+1})$. This will allow an estimate of the form $\|B_{n+1}\|_j \leq (q_n b_{n+1})^{R(n)}$, which will ensure the convergence of T_n .

Lemma 2.6. *Let*

$$m_n = \frac{q_{n+1}}{q_n} - 1 - b_{n+1} \left\lfloor \frac{\frac{q_{n+1}}{q_n} - 1}{b_{n+1}} \right\rfloor$$

and for $0 \leq l \leq b_{n+1} - 1$, let

$$k_n(l) = \left\lfloor la_{n+1} \frac{q_n}{q_{n+1}} \right\rfloor$$

$$r_n(l) = la_{n+1} - \frac{q_{n+1}}{q_n} k_n(l)$$

We have:

$$R^{(n)} = \bigcup_{l=0}^{b_{n+1}-1} R^{(n),l}$$

with, if $0 \leq l \leq m_n$:

$$R^{(n),l} = I \times \left(\frac{k_n(l)}{q_n} + \frac{r_n(l)}{q_{n+1}} + \left[0, \frac{\left\lfloor \frac{\frac{q_{n+1}-1}{q_n}}{b_{n+1}} \right\rfloor + 1}{q_{n+1}} \right] \right)$$

and if $m_n + 1 \leq l \leq b_{n+1} - 1$:

$$R^{(n),l} = I \times \left(\frac{k_n(l)}{q_n} + \frac{r_n(l)}{q_{n+1}} + \left[0, \frac{\left\lfloor \frac{\frac{q_{n+1}-1}{q_n}}{b_{n+1}} \right\rfloor} \right] \right)$$

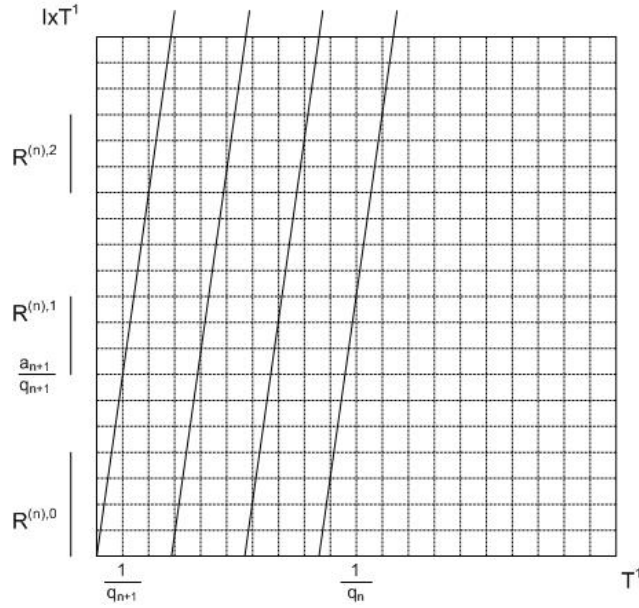

Figure 1: The set $R^{(n)} = K_n^{n+1}(I \times [0, 1/q_n])$ for $q_n = 2$, $q_{n+1} = 20$, $a_{n+1} = 7$, $b_{n+1} = 3$. $R^{(n)} = R^{(n),0} \cup R^{(n),1} \cup R^{(n),2}$ has $b_{n+1} = 3$ connected components. The oblique lines represent the graph of the map $x \mapsto a_{n+1}x$ from \mathbb{T}^1 to itself. In this illustration, $k_n(0) = k_n(1) = 0$, $k_n(2) = 1$, $r_n(0) = 0$, $r_n(1) = 7$, $r_n(2) = 4$.

Proof. We have:

$$R^{(n)} = I \times \bigcup_{i=0}^{q_{n+1}/q_n - 1} \left[\frac{a_{n+1}i}{q_{n+1}}, \frac{a_{n+1}i}{q_{n+1}} + \frac{1}{q_{n+1}} \right]$$

For $i = 0, \dots, q_{n+1}/q_n - 1$, we make the Euclidean division of i by b_{n+1} . We get:

$$i = k_i b_{n+1} + r_i$$

with $0 \leq r_i \leq b_{n+1} - 1$ and $0 \leq k_i \leq \left\lfloor \frac{q_{n+1} - 1}{b_{n+1}} \right\rfloor$. Since $a_{n+1}b_{n+1}/q_{n+1} = 1/q_{n+1} \pmod{1}$, we get:

$$R^{(n)} = I \times \bigcup_{i=0}^{q_{n+1}/q_n - 1} \left[\frac{a_{n+1}r_i + k_i}{q_{n+1}}, \frac{a_{n+1}r_i + k_i}{q_{n+1}} + \frac{1}{q_{n+1}} \right]$$

Moreover, we have:

$$\begin{aligned} \{0, \dots, q_{n+1}/q_n - 1\} &= \{0, \dots, b_{n+1} - 1\} \cup (b_{n+1} + \{0, \dots, b_{n+1} - 1\}) \cup \dots \\ \dots \cup &\left(b_{n+1} \left(\left\lfloor \frac{q_{n+1} - 1}{q_n} \right\rfloor / b_{n+1} - 1 \right) + \{0, \dots, b_{n+1} - 1\} \right) \cup \left(b_{n+1} \left(\left\lfloor \frac{q_{n+1} - 1}{q_n} \right\rfloor / b_{n+1} \right) + \{0, \dots, m_n\} \right) \end{aligned}$$

Therefore,

$$\begin{aligned} R^{(n)} &= I \times \bigcup_{k_i=0}^{\lfloor (q_{n+1}-1)/b_{n+1} \rfloor - 1} \bigcup_{r_i=0}^{b_{n+1}-1} \left[\frac{a_{n+1}r_i + k_i}{q_{n+1}}, \frac{a_{n+1}r_i + k_i}{q_{n+1}} + \frac{1}{q_{n+1}} \right] \cup \\ &\bigcup_{r_i=0}^{m_n} \left[\frac{a_{n+1}r_i + \lfloor (q_{n+1}-1)/b_{n+1} \rfloor}{q_{n+1}}, \frac{a_{n+1}r_i + \lfloor (q_{n+1}-1)/b_{n+1} \rfloor}{q_{n+1}} + \frac{1}{q_{n+1}} \right] \\ R^{(n)} &= I \times \bigcup_{l=0}^{m_n} \left(\frac{a_{n+1}l}{q_{n+1}} + \bigcup_{k_i=0}^{\lfloor (q_{n+1}-1)/b_{n+1} \rfloor} \left[\frac{k_i}{q_{n+1}}, \frac{k_i}{q_{n+1}} + \frac{1}{q_{n+1}} \right] \right) \cup \\ &\bigcup_{l=m_n+1}^{b_{n+1}-1} \left(\frac{a_{n+1}l}{q_{n+1}} + \bigcup_{k_i=0}^{\lfloor (q_{n+1}-1)/b_{n+1} \rfloor - 1} \left[\frac{k_i}{q_{n+1}}, \frac{k_i}{q_{n+1}} + \frac{1}{q_{n+1}} \right] \right) \\ R^{(n)} &= I \times \bigcup_{l=0}^{m_n} \left(\frac{a_{n+1}l}{q_{n+1}} + \left[0, \frac{\lfloor (q_{n+1}-1)/b_{n+1} \rfloor + 1}{q_{n+1}} \right] \right) \bigcup_{l=m_n+1}^{b_{n+1}-1} \left(\frac{a_{n+1}l}{q_{n+1}} + \left[0, \frac{\lfloor (q_{n+1}-1)/b_{n+1} \rfloor}{q_{n+1}} \right] \right) \end{aligned}$$

Finally, the Euclidean division of la_{n+1} by q_{n+1}/q_n gives:

$$la_{n+1} = k_n(l)q_{n+1}/q_n + r_n(l)$$

with

$$k_n(l) = \left\lfloor la_{n+1} \frac{q_n}{q_{n+1}} \right\rfloor$$

$$r_n(l) = la_{n+1} - \frac{q_{n+1}}{q_n} \left\lfloor la_{n+1} \frac{q_n}{q_{n+1}} \right\rfloor$$

We get:

$$R^{(n)} = I \times \bigcup_{l=0}^{m_n} \frac{k_n(l)}{q_n} + \frac{r_n(l)}{q_{n+1}} + \left[0, \frac{\left\lfloor \frac{q_{n+1}-1}{b_{n+1}} \right\rfloor + 1}{q_{n+1}} \right] \left[\bigcup_{l=m_{n+1}}^{b_{n+1}-1} \frac{k_n(l)}{q_n} + \frac{r_n(l)}{q_{n+1}} + \left[0, \frac{\left\lfloor \frac{q_{n+1}-1}{b_{n+1}} \right\rfloor}{q_{n+1}} \right] \right]$$

□

The next section is dedicated to the construction of the sequence of diffeomorphisms B_n satisfying the conditions of lemma 2.4.

3 The sequence of conjugacies

In this section, we construct a sequence of diffeomorphisms B_n on M satisfying the conditions of lemma 2.4, such that $\|B_n\|_n \leq (q_{n-1}b_n)^{R_2(n-1)}$ for some $R_2(n)$, and such that $B_n = Id$ on a neighborhood of ∂M , in order to ensure that $(D^j T)_{|\partial M} = (D^j S_\alpha)_{|\partial M}$ for any $j \in \mathbb{N}$.

Proposition 3.1. *There exists a sequence of diffeomorphisms $B_n \in \text{Diff}^\infty(M, \mu)$ such that B_n and $A_{n+1} = B_{n+1}B_n^{-1}$ satisfy the following conditions:*

1. (convergence of the partition ξ_n^m to ξ_n^∞)

$$\sum_{m \geq 0} q_m \mu \left(\Delta_{0, q_m} \Delta A_{m+1}^{-1} R^{(m)} \right) < +\infty$$

2. (generation) There is a set $E_{n+1} \subset M$ such that $\sum_{n \geq 0} \mu(E_{n+1}^c) < +\infty$ and such that

$$\text{diam} \left(A_{n+1}^{-1} \left(\Delta_{0, q_{n+1}} \cap E_{n+1} \right) \right) \leq \frac{1}{2^n \|B_n\|_1}$$

3. (equivariance)

$$A_{n+1} S_{\frac{1}{q_n}} \perp = S_{\frac{1}{q_n}} \perp A_{n+1}$$

4. (polynomial estimation) There is a fixed sequence $R_2(n) \in \mathbb{N}$ such that

$$\|A_{n+1}\|_{n+1} \leq (q_n b_{n+1})^{R_2(n)}$$

5. (identity on a neighborhood of the boundary) $B_n = Id$ on a neighborhood of ∂M .

Remark 3.2. Specification 2 above implies that ξ_n generates (and so ξ_n^∞ , by lemma 2.4), see [7, 4].

We construct B_n recursively. We suppose that B_n exists and satisfies these specifications, and we construct A_{n+1} .

The diffeomorphism A_{n+1} is constructed in three steps, each step giving a smooth, measure-preserving, equivariant and polynomially controlled map. In the first step, lemma 3.3, we construct a smooth map A_{n+1}^1 that "quasi-cuts" $I \times [0, 1/q_n[$ into b_{n+1} vertical slices, and then rotates each slice Γ_l by an angle $k_n(l)/q_n$ along the periodic flow S_t .

In the second step, we construct a second map A_{n+1}^2 that "quasi-sends" each vertical slice $A_{n+1}^1(\Gamma_l)$ into a suitable connected component of $R^{(n)}$ (see lemma 2.6 for the decomposition of $R^{(n)}$ into connected components). These two steps ensure that A_{n+1} "quasi-sends" $I \times [0, 1/q_n[$ to $R^{(n)}$. It ensures that ξ_n converges.

In the third step, we obtain the generation of ξ_n . We use A_{n+1}^3 to quasi-rotate slices inside each connected component of $R^{(n)}$. These slices are chosen sufficiently thin to ensure that the diameter of $A_{n+1}^{-1}(I \times [l/q_{n+1}, (l+1)/q_{n+1}[$) is small, but these slices are not too thin to ensure that $\|A_{n+1}\|_{n+1} \leq (b_{n+1}q_n)^{R_2^{(n)}}$, which enables the convergence of T_n . This last step completes the construction.

Let $l_0, \dots, l_{b_{n+1}-1}$ integers such that $0 = r_n(l_0) < \dots < r_n(l_{b_{n+1}-1}) \leq q_{n+1}/q_n - 1$. Let $l_{b_{n+1}} = b_{n+1}$ and $r_n(l_{b_{n+1}}) = q_{n+1}/q_n$.

3.1 Construction in dimension 2

We suppose $M = [0, 1] \times \mathbb{T}^1$. The first step is based on the following lemma, which is analogous to [4, lemma 4.2]:

Lemma 3.3. *Let $\frac{1}{b_{n+1}} > \epsilon_1 > 0$, and $\Gamma_i = \left[r_n(l_i) \frac{q_n}{q_{n+1}}, r_n(l_{i+1}) \frac{q_n}{q_{n+1}} - \epsilon_1 \right] \times \left[0, \frac{1}{q_n} \right[$ for $0 \leq i \leq b_{n+1} - 1$. There is a smooth measure-preserving diffeomorphism A_{n+1}^1 of $[0, 1] \times \mathbb{T}^1$ such that:*

1.

$$A_{n+1}^1 S_{\frac{1}{q_n}} = S_{\frac{1}{q_n}} A_{n+1}^1$$

2.

$$A_{n+1}^1(\Gamma_i) = S_{\frac{k_n(l_i)}{q_n}} \Gamma_i$$

3.

$$\|A_{n+1}^1\|_j \leq \frac{1}{\epsilon_1^j} \|\phi\|_j$$

where ϕ is a fixed smooth diffeomorphism, independent of n and ϵ_1 .

We take $\epsilon_1 = \frac{1}{2^n b_{n+1}}$ and we let:

$$E_{n+1}^1 = \bigcup_{i=0}^{b_{n+1}-1} \left[r(l_i) \frac{q_n}{q_{n+1}}, r(l_{i+1}) \frac{q_n}{q_{n+1}} - \epsilon_1 \right] \times \mathbb{T}^1$$

We have:

$$\mu(E_{n+1}^{1c}) = b_{n+1} \epsilon_1 = \frac{1}{2^n}$$

In the second step, we shrink $A_{n+1}^1(\Gamma_i)$ horizontally by a factor q_n , we expand it vertically by the same factor, and we rotate it by a $\pi/2$ angle (except in a neighborhood of the border of $I \times [0, 1/q_n]$). Thus, $A_{n+1}^1(\Gamma_i)$ is quasi-sent to a connected component of $R^{(n)}$.

We have the lemma (see [4]):

Lemma 3.4. *For $0 \leq i \leq b_{n+1} - 1$, let $\Gamma'_i = \left[r_n(l_i) \frac{q_n}{q_{n+1}}, r_n(l_{i+1}) \frac{q_n}{q_{n+1}} \right] \times [0, \frac{1}{q_n}]$. There exists a smooth measure-preserving diffeomorphism A_{n+1}^2 of $[0, 1] \times \mathbb{T}^1$, equivariant by $S_{\frac{1}{q_n}}$ and a measurable set E_{n+1}^2 that is globally invariant by $S_{\frac{1}{q_n}}$ and A_{n+1}^2 such that:*

$$A_{n+1}^2(\Gamma'_i \cap E_{n+1}^2) = I \times \left[\frac{r_n(l_i)}{q_{n+1}}, \frac{r_n(l_{i+1})}{q_{n+1}} \right] \cap E_{n+1}^2$$

Moreover, there is an explicit function $R_2(j)$, depending only on j , such that:

$$\|A_{n+1}^2\|_j \leq (q_n)^{R_2(j)}$$

and such that if $\Gamma \subset M$ with $\text{diam}(\Gamma) \leq x$, then:

$$\text{diam}\left((A_{n+1}^2)^{-1}\left(\Gamma \cap E_{n+1}^2\right)\right) \leq q_n x$$

Combined with lemma 3.3, lemma 3.4 gives the following corollary, which implies the convergence of the partition ξ_n to ξ_n^∞ (see [4]):

Corollary 3.5. *We have the estimation:*

$$\mu\left(A_{n+1}^2 A_{n+1}^1(I \times [0, 1/q_n]) \Delta R^{(n)}\right) \leq \frac{8}{2^n q_n}$$

In the third step, it remains to obtain the generation of the sequence of partitions ξ_n^∞ , without affecting the properties obtained in the first two steps. In particular, we cannot exactly proceed as in [4], because b_{n+1} can be a bounded sequence (while in [4], the sequence k_n , analogous to b_{n+1} , is larger than q_n). We need to refine the approach of [4]. This third step is based on the following lemma and its corollary:

Lemma 3.6. *For any integer $w \geq 1$, there is a smooth, measure-preserving, and $S_{\frac{1}{q_n}}$ -equivariant diffeomorphism A_{n+1}^3 , and an explicit sequence of integers $R_3(n)$, such that:*

$$\|A_{n+1}^3\|_{n+1} \leq \left(\frac{q_{n+1}}{w}\right)^{R_3(n)}$$

and there exists a $S_{\frac{1}{q_n}}$ -invariant and A_{n+1}^3 -invariant set E_{n+1}^3 such that $\mu(E_{n+1}^{3c}) \leq 4/2^n$, and such that for any $i = 0, \dots, q_{n+1} - 1$, we have:

$$\text{diam}\left((A_{n+1}^3)^{-1}\left([0, 1] \times [i/q_{n+1}, (i+1)/q_{n+1}[) \cap E_{n+1}^3\right)\right) \leq \max\left(\frac{1}{w}, \frac{2w}{q_{n+1}}\right)$$

We obtain the corollary:

Corollary 3.7. *There exists an explicit sequence of integers $R_4(n)$ depending only on n , there is a smooth, measure-preserving, and $S_{\frac{1}{q_n}}$ -equivariant diffeomorphism A_{n+1} , such that:*

$$\|A_{n+1}\|_{n+1} \leq (b_{n+1}q_n)^{R_4(n)}$$

and there exists a $S_{\frac{1}{q_n}}$ -invariant and A_{n+1} -invariant set E_{n+1} such that $\mu(E_{n+1}^c) \leq 4/2^n$, and such that for any $i = 0, \dots, q_{n+1} - 1$, we have:

$$\text{diam}\left((A_{n+1})^{-1}([0, 1] \times [i/q_{n+1}, (i+1)/q_{n+1}]) \cap E_{n+1}\right) \leq \frac{1}{2^n \|B_n\|_1}$$

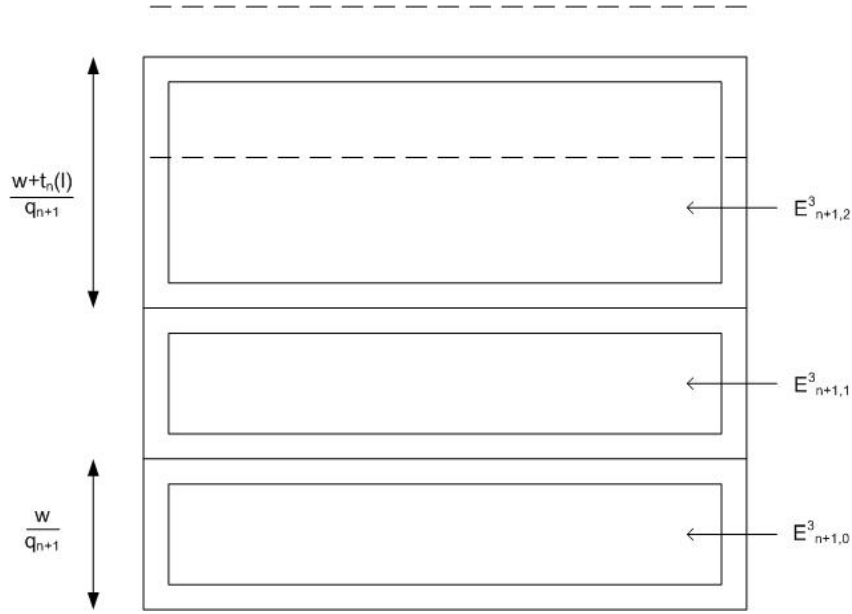

Figure 2: Illustration of the third step (generation): a connected component of $R^{(n)}$ with $h_n(l) = 3$.

Proof of lemma 3.6. We define A_{n+1}^3 on $R^{(n)}$, and since $R^{(n)}$ is a fundamental domain of $S_{\frac{1}{q_n}}$, we can extend it to all M by $S_{\frac{1}{q_n}}$ -periodicity. To that aim, we define A_{n+1}^3 on each connected component of $R^{(n)}$ (see figure 3.1).

Let $f_n(l) = \left\lfloor \frac{q_{n+1}-1}{b_{n+1}} \right\rfloor + 1$ if $0 \leq l \leq m_n$ and $f_n(l) = \left\lfloor \frac{q_{n+1}-1}{b_{n+1}} \right\rfloor$ if $m_n + 1 \leq l \leq b_{n+1} - 1$ ($f_n(l)/q_{n+1}$ is the width of a connected component of $R^{(n)}$, see lemma 2.6). We perform the Euclidean division of $f_n(l)$ by w :

$$f_n(l) = h_n(l)w + t_n(l)$$

with $0 \leq t_n(l) \leq w - 1$.

We also need to recall the definition of a "quasi-rotation" by $\pi/2$ [7]:

Proposition 3.8. For any $n \geq 1$, there is a smooth measure-preserving map

$\phi_n : [0, 1]^2 \rightarrow [0, 1]^2$ (called "quasi-rotation") such that $\phi_n = R_{\pi/2}$ on $[\frac{1}{2^n}, 1 - \frac{1}{2^n}]^2$ and $\phi_n = Id$ on a neighborhood of the boundary of $[0, 1]^2$.

Let $p \geq 2$ a real number and

$$\begin{aligned} C_p : [0, 1] \times \left[0, \frac{1}{p}\right] &\rightarrow [0, 1] \times [0, 1] \\ (x, y) &\mapsto (x, py) \end{aligned}$$

Let $\phi_{n,p} = C_p^{-1} \phi_n C_p$. The map $\phi_{n,p}$ is smooth and measure-preserving. By the Faa-di-Bruno formula, there exists a fixed function $R_5(j)$ such that

$$\|\phi_{n,p}\|_j \leq p^{R_5(j)} \|\phi_n\|_j$$

Since ϕ_n is fixed, by choosing a larger $R_5(n)$, we have:

$$\|\phi_{n,p}\|_{n+1} \leq p^{R_5(n)}$$

For $0 \leq l \leq b_{n+1}$, on $[0, 1] \times \left(\frac{k_n(l)}{q_n} + \frac{r_n(l)}{q_{n+1}} + \left[0, \frac{w}{q_{n+1}}\right]\right)$, we let $A_{n+1}^3 = \phi_{n, q_{n+1}/w}$ and

$$E_{n+1,0}^3 = \left[\frac{1}{2^{n+1}}, 1 - \frac{1}{2^{n+1}} \right] \times \left(\frac{k_n(l)}{q_n} + \frac{r_n(l)}{q_{n+1}} + \left[\frac{w}{2^{n+1}q_{n+1}}, \frac{w}{q_{n+1}} - \frac{w}{2^{n+1}q_{n+1}} \right] \right)$$

We extend A_{n+1}^3 to $[0, 1] \times \left(\frac{k_n(l)}{q_n} + \frac{r_n(l)}{q_{n+1}} + \left[0, \frac{(h_n(l)-1)w}{q_{n+1}}\right]\right)$ by $S_{\frac{w}{q_{n+1}}}$ -equivariance.

Likewise, for $x = 1, \dots, h_n(l) - 2$, we define: $E_{n+1,x}^3 = \frac{xw}{q_{n+1}} + E_{n+1,0}^3$.

On $[0, 1] \times \left(\frac{k_n(l)}{q_n} + \frac{r_n(l)}{q_{n+1}} + \left[\frac{(h_n(l)-1)w}{q_{n+1}}, \frac{h_n(l)w+t_n(l)}{q_{n+1}}\right]\right)$, we let $A_{n+1}^3 = \phi_{n, \frac{q_{n+1}}{w+t_n(l)}}$. This completes the construction of A_{n+1}^3 on $R^{(n)}$. By $S_{\frac{1}{q_n}}$ -equivariance, we get the definition of A_{n+1}^3 on the whole manifold M . Moreover, since $0 \leq t_n(l) \leq w - 1$, there exists $R_3(n)$ such that:

$$\|A_{n+1}^3\|_{n+1} \leq \max \left(\|\phi_{n, \frac{q_{n+1}}{w}}\|_{n+1}, \max_{0 \leq l \leq b_{n+1}-1} \|\phi_{n, \frac{q_{n+1}}{w+t_n(l)}}\|_{n+1} \right) \leq \left(\frac{q_{n+1}}{w} \right)^{R_3(n)}$$

Let:

$$E_{n+1, h_n(l)-1}^3 = \left[\frac{1}{2^{n+1}}, 1 - \frac{1}{2^{n+1}} \right] \times \left(\frac{k_n(l)}{q_n} + \frac{r_n(l)}{q_{n+1}} + \frac{(h_n(l)-1)w}{q_{n+1}} + \left[\frac{w+t_n(l)}{q_{n+1}2^{n+1}}, \frac{w+t_n(l)}{q_{n+1}} - \frac{w+t_n(l)}{q_{n+1}2^{n+1}} \right] \right)$$

We let $E_{n+1}^{3,0} = \bigcup_{x=0}^{h_n(l)-1} E_{n+1,x}^3$, and $E_{n+1}^3 = \bigcup_{y=0}^{q_n-1} \frac{y}{q_n} + E_{n+1}^{3,0}$. This completes the construction of E_{n+1}^3 . Moreover, we have: $\mu(E_{n+1}^{3c}) \leq 4/2^n$.

Moreover, since $t_n(l) \leq w$, then for any $i = 0, \dots, q_{n+1} - 1$, we have:

$$\text{diam} \left((A_{n+1}^3)^{-1} \left([i/q_{n+1}, (i+1)/q_{n+1}] \times [0, 1] \right) \cap E_{n+1}^3 \right) \leq \max \left(\frac{1}{w}, \max_{0 \leq l \leq b_{n+1}-1} \frac{w+t_n(l)}{q_{n+1}} \right) \leq \max \left(\frac{1}{w}, \frac{2w}{q_{n+1}} \right)$$

□

Proof of corollary 3.7. By the recurrence assumption on B_n , there exists $R_6(n)$ such that $\|B_n\|_1 \leq (b_n q_{n-1})^{R_6(n-1)}$. Let

$$w = \left\lfloor \frac{q_{n+1}}{2^{n+1} q_n^2 (b_n q_{n-1})^{R_6(n-1)}} \right\rfloor$$

This choice of w determines A_{n+1}^3 in lemma 3.6. Let $A_{n+1} = A_{n+1}^3 A_{n+1}^2 A_{n+1}^1$ and $E_{n+1} = E_{n+1}^3 \cap A_{n+1}^3(E_{n+1}^2) \cap A_{n+1}^3 A_{n+1}^2(E_{n+1}^1)$. By lemma 3.6, we have:

$$\|A_{n+1}^3\|_{n+1} \leq (q_{n+1})^{R_3(n)} \left(\frac{2^{n+2} q_n^2 (b_n q_{n-1})^{R_6(n-1)}}{q_{n+1}} \right)^{R_3(n)} \leq (b_{n+1} q_n)^{R_7(n)}$$

for a fixed sequence $R_7(n)$. This ensures the existence of $R_4(n)$ such that:

$$\|A_{n+1}\|_{n+1} \leq (b_{n+1} q_n)^{R_4(n)}$$

Moreover, we have:

$$w \leq \frac{q_{n+1}}{2^{n+1} q_n^2 \|B_n\|_1}$$

Since q_n divides q_{n+1} , and by the left-hand side of assumption 3 of lemma 1.5, we have:

$$\left| \frac{p_{n+1}}{q_{n+1}} - \frac{p_n}{q_n} \right| \geq \frac{1}{q_{n+1}}$$

Therefore, by the right-hand side of assumption 3, $q_{n+1} \geq (b_{n+1} q_n)^{R_1(n)}$.

We will choose an explicit sequence $R_1(n)$ such that:

$$(b_{n+1} q_n)^{R_1(n)} \geq \left(2^{n+1} q_n^{3/2} (b_n q_{n-1})^{R_6(n-1)} \right)^2$$

This choice implies:

$$q_{n+1} \geq \left(2^{n+1} q_n^{3/2} (b_n q_{n-1})^{R_6(n-1)} \right)^2$$

Therefore,

$$w \geq \frac{q_{n+1}}{2^{n+1} q_n^2 (b_n q_{n-1})^{R_6(n-1)}} - 1 \geq \frac{1}{2} \frac{\left(2^{n+1} q_n^{3/2} (b_n q_{n-1})^{R_6(n-1)} \right)^2}{2^{n+1} q_n^2 (b_n q_{n-1})^{R_6(n-1)}} \geq 2^n q_n \|B_n\|_1$$

Therefore, by lemma 3.6, for any $i = 0, \dots, q_{n+1} - 1$, we have:

$$\text{diam} \left((A_{n+1}^3)^{-1} \left([0, 1] \times [i/q_{n+1}, (i+1)/q_{n+1}] \right) \cap E_{n+1}^3 \right) \leq \frac{1}{2^n q_n \|B_n\|_1}$$

Therefore, by lemma 3.4,

$$\text{diam} \left((A_{n+1}^2)^{-1} \left((A_{n+1}^3)^{-1} \left([0, 1] \times [i/q_{n+1}, (i+1)/q_{n+1}] \right) \cap E_{n+1}^3 \right) \right) \cap E_{n+1}^2 \leq \frac{1}{2^n \|B_n\|_1}$$

and therefore, we also have:

$$\text{diam} \left((A_{n+1}^1)^{-1} \left((A_{n+1}^2)^{-1} \left((A_{n+1}^3)^{-1} \left([0, 1] \times [i/q_{n+1}, (i+1)/q_{n+1}] \right) \cap E_{n+1}^3 \right) \right) \cap E_{n+1}^2 \right) \cap E_{n+1}^1 \leq \frac{1}{2^n \|B_n\|_1}$$

□

3.2 Construction in higher dimensions

The construction in higher dimensions is slightly different of [4]. The first two steps are the same as in dimension 2 (we make the construction in the plan (x_1, x_d) , see [4]), and for the third step (generation), we combine all $d - 1$ dimensions. The following lemma generalizes lemma 3.6:

Lemma 3.9. *For any integers $w_1, \dots, w_{d-1} \geq 1$ such that $2 \prod_{i=1}^{d-1} w_i \leq q_{n+1}$, there is a smooth, measure-preserving, and $S_{\frac{1}{q_n}}$ -equivariant diffeomorphism A_{n+1}^3 , and an explicit sequence of integers $R_8(n)$, such that:*

$$\|A_{n+1}^3\|_{n+1} \leq \left(\frac{q_{n+1}}{w_1}\right)^{R_8(n)}$$

and there exists a $S_{\frac{1}{q_n}}$ -invariant and A_{n+1}^3 -invariant set E_{n+1}^3 such that $\mu(E_{n+1}^{3c}) \leq 4/2^n$, and such that for any $i = 0, \dots, q_{n+1} - 1$, we have:

$$\text{diam}\left((A_{n+1}^3)^{-1}\left([0, 1]^{d-1} \times [i/q_{n+1}, (i+1)/q_{n+1}[\right) \cap E_{n+1}^3\right) \leq \max\left(\frac{1}{w_1}, \dots, \frac{1}{w_{d-1}}, \frac{2^{d-1}w_1 \dots w_{d-1}}{q_{n+1}}\right)$$

As in dimension 2, we let $A_{n+1} = A_{n+1}^3 A_{n+1}^2 A_{n+1}^1$ and

$$E_{n+1} = E_{n+1}^3 \cap A_{n+1}^3(E_{n+1}^2) \cap A_{n+1}^3 A_{n+1}^2(E_{n+1}^1)$$

We obtain the corollary:

Corollary 3.10. *There exists an explicit sequence of integers $R_9(n)$ depending only on n , there is a smooth, measure-preserving, and $S_{\frac{1}{q_n}}$ -equivariant diffeomorphism A_{n+1} , such that:*

$$\|A_{n+1}\|_{n+1} \leq (b_{n+1} q_n)^{R_9(n)}$$

and there exists a $S_{\frac{1}{q_n}}$ -invariant and A_{n+1} -invariant set E_{n+1} such that $\mu(E_{n+1}^c) \leq 4/2^n$, and such that for any $i = 0, \dots, q_{n+1} - 1$, we have:

$$\text{diam}\left((A_{n+1})^{-1}\left([0, 1]^{d-1} \times [i/q_{n+1}, (i+1)/q_{n+1}[\right) \cap E_{n+1}\right) \leq \frac{1}{2^n \|B_n\|_1}$$

Proof of lemma 3.9. We denote:

$$\begin{aligned} \tilde{A}_{n+1,w}^3 : [0, 1] \times \mathbb{T}^1 &\rightarrow [0, 1] \times \mathbb{T}^1 \\ (x, y) &\mapsto (\tilde{A}_{n+1,1,w}^3(x, y), \tilde{A}_{n+1,2,w}^3(x, y)) \end{aligned}$$

the map A_{n+1}^3 of the 2-dimensional case, given by lemma 3.6, associated with the integer w . For $i = 1, \dots, d - 1$, we denote:

$$A_{n+1,w}^{3,i}(x_1, \dots, x_d) = (x_1, \dots, x_{i-1}, \tilde{A}_{n+1,1,w}^3(x_i, x_d), x_{i+2}, \dots, \tilde{A}_{n+1,2,w}^3(x_i, x_d))$$

We let: $A_{n+1}^3 = A_{n+1,w_1}^{3,1} A_{n+1,w_1 w_2}^{3,2} \dots A_{n+1,w_1 \dots w_{d-1}}^{3,d-1}$ (see figures 3, 4, 5). We define E_{n+1}^3 by analogy with lemma 3.6. □

Proof of corollary 3.10. The proof is analogous to the proof of corollary 3.7. We let:

$$w_1 = \left| \frac{q_{n+1}}{(2^{n+1} q_n (b_n q_{n-1})^{R_6(n-1)})^d} \right|$$

and for $i = 2, \dots, d - 1$, $w_i = 2^n q_n (b_n q_{n-1})^{R_6(n-1)}$.

As in lemma 3.6, there exists $R_9(n)$ such that:

$$\|A_{n+1}\|_{n+1} \leq (b_{n+1} q_n)^{R_9(n)}$$

For $i = 2, \dots, d - 1$, we have:

$$\frac{1}{w_i} \leq \frac{1}{2^n q_n (b_n q_{n-1})^{R_6(n-1)}} \leq \frac{1}{2^n q_n \|B_n\|_1}$$

Moreover, we have:

$$\frac{2^{d-1} w_1 w_2 \dots w_{d-1}}{q_{n+1}} \leq \frac{1}{2^{n+1} q_n \|B_n\|_1}$$

We will choose an explicit sequence $R_1(n)$ such that:

$$(b_{n+1} q_n)^{R_1(n)} \geq (2^n q_n (b_n q_{n-1})^{R_6(n-1)})^{d+1}$$

This choice implies:

$$q_{n+1} \geq (2^n q_n (b_n q_{n-1})^{R_6(n-1)})^{d+1}$$

Therefore,

$$\frac{1}{w_1} \leq \frac{(2^n q_n (b_n q_{n-1})^{R_6(n-1)})^{d-1}}{q_{n+1}} \leq \frac{1}{2^n q_n \|B_n\|_1}$$

By combining lemma 3.9 and lemma 3.4, we obtain the corollary. □

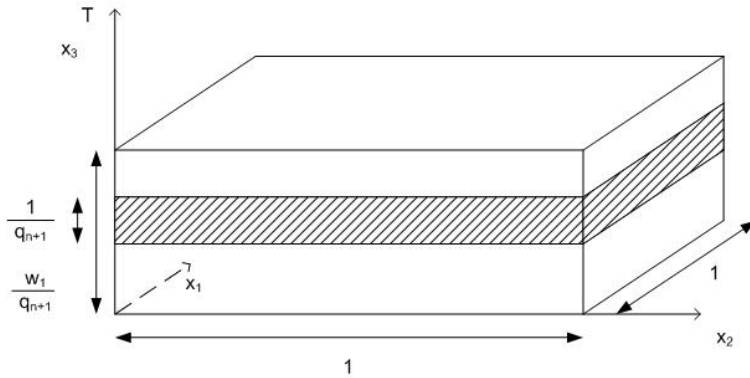

Figure 3: An element $[0, 1]^2 \times [i/q_{n+1}, (i+1)/q_{n+1}[$ (we take $d = 3$), before the application of $(A_{n+1}^3)^{-1} = (A_{n+1, w_1 w_2}^{3,2})^{-1} (A_{n+1, w_1}^{3,1})^{-1}$. Its size is $1 \times 1 \times 1/q_{n+1}$.

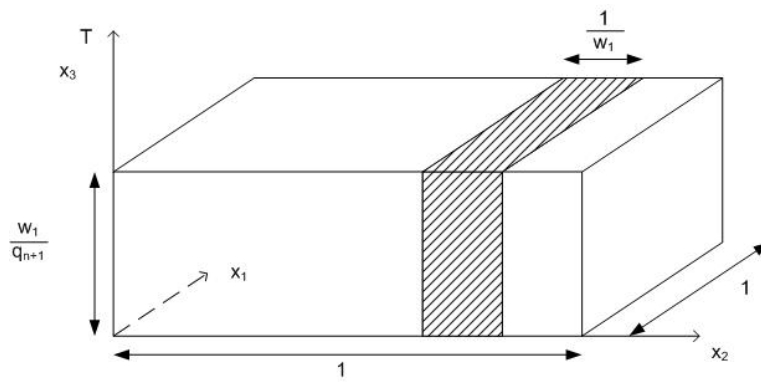

Figure 4: The element $(A_{n+1, w_1}^{3,1})^{-1}([0, 1]^2 \times [i/q_{n+1}, (i+1)/q_{n+1}[) \cap E_{n+1}^3$. Its size is less than $1 \times 1/w_1 \times w_1/q_{n+1}$.

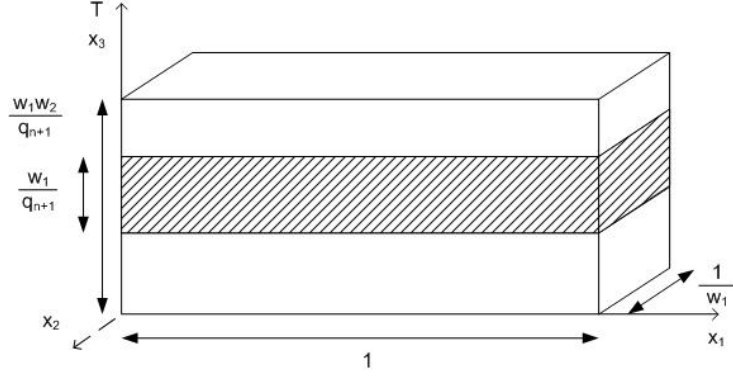

Figure 5: $(A_{n+1, w_1}^{3,1})^{-1}([0, 1]^2 \times [i/q_{n+1}, (i+1)/q_{n+1}[) \cap E_{n+1}^3$, in the plan (x_1, x_3) .

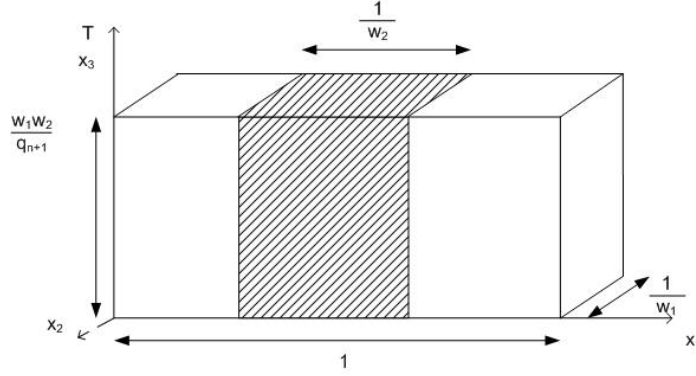

Figure 6: $(A_{n+1, w_1 w_2}^{3,2})^{-1} (A_{n+1, w_1}^{3,1})^{-1} ([0, 1]^2 \times [i/q_{n+1}, (i+1)/q_{n+1}[) \cap E_{n+1}^3$, in the plan (x_1, x_3) . Its size is less than $1/w_2 \times 1/w_1 \times w_1 w_2 / q_{n+1}$.

3.3 Convergence of the sequence of diffeomorphisms and ergodicity of the limit T . Proof that T is a pseudo-rotation in dimension 2

By combining lemma 2.4, corollary 2.5, and proposition 3.1, and since ξ_n generates, then in order to complete the proof of lemma 1.5, it remains to show that $T_n = B_n^{-1} S_{\frac{p_n}{q_n}} B_n$ converges in the smooth topology, and that the limit T of T_n is ergodic.

To show the convergence of $T_n = B_n^{-1} S_{\frac{p_n}{q_n}} B_n$, by the Cauchy criterion, it suffices to show that $\sum_{n \geq 0} d_n(T_{n+1}, T_n)$ converges. We combine the estimation of B_{n+1} and the assumption 3 of lemma 1.5 of closeness between p_{n+1}/q_{n+1} and p_n/q_n . We recall the lemma [7, p.1812]:

Lemma 3.11. *Let $k \in \mathbb{N}$. There is a constant $C(k, d)$ such that, for any $h \in \text{Diff}(M)$, $\alpha_1, \alpha_2 \in \mathbb{R}$, we have:*

$$d_k(hS_{\alpha_1} h^{-1}, hS_{\alpha_2} h^{-1}) \leq C(k, d) \|h\|_{k+1}^{k+1} |\alpha_1 - \alpha_2|$$

Since $T_n = B_n^{-1} S_{\frac{p_n}{q_n}} B_n = B_{n+1}^{-1} S_{\frac{p_n}{q_n}} B_{n+1}$, we obtain, for a fixed sequence $R_{10}(n)$ (that depends on n and on the dimension d):

$$\begin{aligned} d_n(T_{n+1}, T_n) &= d_n(B_{n+1}^{-1} S_{\frac{p_{n+1}}{q_{n+1}}} B_{n+1}, B_{n+1}^{-1} S_{\frac{p_n}{q_n}} B_{n+1}) \leq C(k, d) \|B_{n+1}\|_{n+1}^{n+1} \left| \frac{p_{n+1}}{q_{n+1}} - \frac{p_n}{q_n} \right| \\ &\leq (b_{n+1} q_n)^{R_{10}(n)} \left| \frac{p_{n+1}}{q_{n+1}} - \frac{p_n}{q_n} \right| \end{aligned}$$

For some choice of the sequence $R_1(n)$ in lemma 1.5, this last estimate guarantees the convergence of T_n in the smooth topology. Moreover, the limit T is ergodic, because it is metrically isomorphic to an irrational rotation of the circle, which is ergodic.

To show corollary 1.3, let us show that T is a pseudo-rotation when $d = 2$.

Proposition 3.12. *When $d = 2$, the limit T of T_n is a pseudo-rotation of angle α .*

Proof. Since $T|_{\partial M} = S_{\alpha|\partial M}$, then T is isotopic to the identity.

Let $\epsilon > 0$ and $n_0 > 0$ fixed such that for any $n \geq n_0$, $|\alpha - p_n/q_n| < \epsilon$ and $\|\tilde{T} - \tilde{T}_n\|_0 < \epsilon$. For any $m \geq 0$, $\tilde{x} \in \tilde{M}$,

$$\frac{p_2(\tilde{T}^m(\tilde{x}) - \tilde{x})}{m} = \frac{p_2(\tilde{T}^m(\tilde{x}) - \tilde{T}_n^m(\tilde{x}))}{m} + \frac{p_2(\tilde{T}_n^m(\tilde{x}) - \tilde{x})}{m}$$

Moreover,

$$|p_2(\tilde{T}^m(\tilde{x}) - \tilde{T}_n^m(\tilde{x}))| \leq \|\tilde{T}^m - \tilde{T}_n^m\|_0$$

and

$$\tilde{T}^m - \tilde{T}_n^m = \tilde{T}^m - \tilde{T}^{m-1} T_n + \dots + \tilde{T} \tilde{T}_n^{m-1} - \tilde{T}_n^m$$

Therefore,

$$|p_2(\tilde{T}^m(\tilde{x}) - \tilde{T}_n^m(\tilde{x}))| \leq \|\tilde{T} - \tilde{T}_n\|_0 (1 + \|DT\|_0 + \dots + \|D(T^{m-1})\|_0)$$

Let $n_m \geq n_0$ such that

$$\|\tilde{T} - \tilde{T}_{n_m}\|_0 \leq \frac{1}{(1 + \|DT\|_0 + \dots + \|D(T^{m-1})\|_0)}$$

We have, for any $\tilde{x} \in \tilde{M}$:

$$\frac{p_2(\tilde{T}^m(\tilde{x}) - \tilde{T}_{n_m}^m(\tilde{x}))}{m} \xrightarrow{m \rightarrow +\infty} 0$$

Moreover, we have: $n_m \rightarrow_{m \rightarrow +\infty} +\infty$. Let us estimate $(p_2(\tilde{T}_n^m(\tilde{x}) - \tilde{x}))/m$. We can write $\tilde{B}_n^{-1} = Id + \psi_n$, with $\psi_n : [0, 1] \times \mathbb{R} \rightarrow [0, 1] \times [0, 1]$ 1-periodic on the second coordinate. In particular, for any n , $\|\psi_n\|_0 \leq 1$. We have:

$$\frac{p_2(\tilde{T}_n^m(\tilde{x}) - \tilde{x})}{m} = \frac{1}{m} p_2(S_{m\tilde{\alpha}_n} \tilde{B}_n(\tilde{x}) - \tilde{B}_n(\tilde{x})) + \frac{1}{m} p_2(\psi_n(S_{m\tilde{\alpha}_n} \tilde{B}_n(\tilde{x})) - \psi_n(\tilde{B}_n(\tilde{x})))$$

$$\frac{p_2(\tilde{T}_n^m(\tilde{x}) - \tilde{x})}{m} = \tilde{\alpha}_n + \frac{1}{m} p_2(\psi_n(S_{m\tilde{\alpha}_n} \tilde{B}_n(\tilde{x})) - \psi_n(\tilde{B}_n(\tilde{x})))$$

Since ψ_n is uniformly C^0 -bounded, then by denoting $\tilde{\alpha}$ the lift in \mathbb{R} of $\alpha \in \mathbb{T}^1$,

$$\frac{p_2(\tilde{T}_{n_m}^m(\tilde{x}) - \tilde{x})}{m} \rightarrow_{m \rightarrow +\infty} \tilde{\alpha}$$

We conclude that $Rot(\tilde{T}) = \{\tilde{\alpha}\}$ and therefore, $Rot(T) = \{\alpha\}$.

□

3.4 Extension to more general manifolds

To extend the construction from $[0, 1]^{d-1} \times \mathbb{T}$ to a general d -dimensional smooth compact connected manifold M , admitting an effective volume-preserving circle action \hat{S}_t , we proceed as in [7, p. 1805] and [4]. We keep denoting S_t the circle action on $[0, 1]^{d-1} \times \mathbb{T}$. For $q \geq 1$, let F_q be the set of fixed points of $\hat{S}_{1/q}$. Let $B = \partial M \cup_{q \geq 1} F_q$ be the set of exceptional points. We recall the proposition:

Proposition 3.13 ([7]). *Let M be a d -dimensional smooth compact connected manifold, with an effective circle action \hat{S}_t , preserving a smooth volume μ . Let S_t denote the circle action on $[0, 1]^{d-1} \times \mathbb{T}$. There exists a continuous surjective map $\Gamma : [0, 1]^{d-1} \times \mathbb{T} \rightarrow M$ such that:*

1. *the restriction of Γ to $]0, 1[^{d-1} \times \mathbb{T}$ is a smooth diffeomorphic embedding.*
2. $\mu(\Gamma(\partial([0, 1]^{d-1} \times \mathbb{T}))) = 0$
3. $B \subset \Gamma(\partial([0, 1]^{d-1} \times \mathbb{T}))$
4. $\Gamma_*(Leb) = \mu$
5. $\hat{S}_t \Gamma = \Gamma S_t$

We use this proposition at each step to apply lemma 1.4. We let $\hat{T}_n : M \rightarrow M$ defined by $\hat{T}_n(x) = \Gamma B_n^{-1} S_{\frac{p_n}{q_n}} B_n \Gamma^{-1}(x)$ if $x \in \Gamma(]0, 1[^{d-1} \times \mathbb{T})$ and $\hat{T}_n(x) = \hat{S}_{\frac{p_n}{q_n}}(x)$ otherwise. To show that \hat{T}_n is a smooth diffeomorphism (which implies that its limit is also smooth), we use the facts that $\Gamma|_{]0, 1[^{d-1} \times \mathbb{T}}$ is a smooth diffeomorphism, that $B_n = Id$ on a neighborhood of $\partial([0, 1]^{d-1} \times \mathbb{T})$ and that $\hat{S}_t \Gamma = \Gamma S_t$. To construct the metric isomorphism $\hat{K}_n^\infty = \Gamma \bar{K}_n^\infty$, we use the fact that the restriction of Γ to a set of full measure is a metric isomorphism. Details are in [4].

Finally, to show that $\hat{T} \in \mathcal{A}_\alpha$, where \hat{T} is the limit of \hat{T}_n in the smooth topology, we let $\hat{H}_n : M \rightarrow M$ defined by $\hat{H}_n(x) = \Gamma B_n \Gamma^{-1}(x)$ if $x \in \Gamma(]0, 1[^{d-1} \times \mathbb{T})$ and $\hat{H}_n(x) = x$ otherwise. We write

$$\hat{T} - \hat{H}_n^{-1} \hat{S}_\alpha \hat{H}_n = \hat{T} - \hat{T}_n + \hat{T}_n - \hat{H}_n^{-1} \hat{S}_\alpha \hat{H}_n$$

We know that $\hat{T} - \hat{T}_n \rightarrow 0$ in the smooth topology. We show that $\hat{T}_n - \hat{H}_n^{-1} \hat{S}_\alpha \hat{H}_n \rightarrow 0$ in the smooth topology by proceeding as in the proof of the convergence of T_n on $[0, 1]^{d-1} \times \mathbb{T}$ in subsection 3.3.

References

- [1] D.V. Anosov and A.B. Katok. New examples in smooth ergodic theory. Ergodic diffeomorphisms. *Trans. Moscow Math. Soc.*, 23(1):35, 1970.

- [2] F. Béguin, S. Crovisier, and F. Le Roux. Construction of curious minimal uniquely ergodic homeomorphisms on manifolds: the Denjoy-Rees technique. In *Annales scientifiques de l'École normale supérieure*, volume 40, pages 251–308. Elsevier, 2007.
- [3] F. Béguin, S. Crovisier, F. Le Roux, and A. Patou. Pseudo-rotations of the closed annulus: variation on a theorem of J Kwapisz. *Nonlinearity*, 17:1427, 2004.
- [4] M Benhenda. Non-standard smooth realization of translations on the torus. *preprint*.
- [5] B. Fayad and A. Katok. Constructions in elliptic dynamics. *Ergodic Theory and Dynamical Systems*, 24(5):1477–1520, 2004.
- [6] B. Fayad and R. Krikorian. Herman's last geometric theorem. *Ann. Sci. Ec. Norm. Sup*, 4:193–219, 2009.
- [7] B. Fayad, M. Saprykina, and A. Windsor. Non-standard smooth realizations of Liouville rotations. *Ergodic Theory and Dynamical Systems*, 27(06):1803–1818, 2007.
- [8] P.R. Halmos. Lectures on ergodic theory. Chelsea Publishing. 1956.
- [9] T. Jäger. Linearization of conservative toral homeomorphisms. *Inventiones Mathematicae*, 176(3):601–616, 2009.
- [10] A.B. Katok and A.M. Stepin. Approximations in ergodic theory. *Russian Mathematical Surveys*, 22(5):77–102, 1967.
- [11] J. Kwapisz. Combinatorics of torus diffeomorphisms. *Ergodic Theory and Dynamical Systems*, 23(2):559–586, 2003.
- [12] J. Wang. A generalization of the line translation theorem. *Arxiv preprint arXiv:1104.5185*, 2011.
- [13] B. Weiss. The isomorphism problem in ergodic theory. *American Mathematical Society*, 78(5), 1972.
- [14] J.C. Yoccoz. Conjugaison différentiable des difféomorphismes du cercle dont le nombre de rotation vérifie une condition diophantienne. *Annales scientifiques de l'École Normale Supérieure Sér. 4*, 17(3):333–359, 1984.