



**HAL**  
open science

# Non-standard smooth realization of translations on the torus

Mostapha Benhenda

► **To cite this version:**

Mostapha Benhenda. Non-standard smooth realization of translations on the torus. 2012. hal-00669027

**HAL Id: hal-00669027**

**<https://hal.science/hal-00669027v1>**

Preprint submitted on 12 Feb 2012

**HAL** is a multi-disciplinary open access archive for the deposit and dissemination of scientific research documents, whether they are published or not. The documents may come from teaching and research institutions in France or abroad, or from public or private research centers.

L'archive ouverte pluridisciplinaire **HAL**, est destinée au dépôt et à la diffusion de documents scientifiques de niveau recherche, publiés ou non, émanant des établissements d'enseignement et de recherche français ou étrangers, des laboratoires publics ou privés.

# Non-standard smooth realization of translations on the torus

Mostapha Benhenda\*

December 27, 2011

## Abstract

Let  $M$  be a smooth compact connected manifold, on which there exists an effective smooth circle action preserving a positive smooth volume. On  $M$ , we construct volume-preserving diffeomorphisms that are metrically isomorphic to ergodic translations on the torus, translations in which one given coordinate of the translation is an arbitrary Liouville number. To obtain this result, we explicitly construct the sequence of successive conjugacies in Anosov-Katok's periodic approximation method, with suitable estimates of their norm. To visualize the construction, we include numerous graphics.

## 1 Introduction

In this paper, we construct non-standard smooth realizations of some ergodic translations on the torus, translations with one arbitrary Liouville coordinate. A *smooth realization* of an abstract system  $(X, T, \nu)$  is a triplet  $(M, f, \mu)$ , where  $M$  is a smooth compact manifold,  $\mu$  a smooth measure on  $M$  and  $f$  a smooth  $\mu$ -preserving diffeomorphism of  $M$ , such that  $(M, f, \mu)$  is metrically isomorphic to  $(X, T, \nu)$ . Moreover, a smooth realization is *non-standard* if  $M$  and  $X$  are not diffeomorphic.

In their 1969 seminal paper, Anosov and Katok [1] constructed ergodic rotations on the circle that admit non-standard smooth realizations. Fayad et al. [3] showed that all Liouvillean rotations of the circle admit non-standard smooth realizations. [2] also enriched the original work of [1]. In their paper [1], Anosov and Katok also constructed ergodic translations on the torus  $\mathbb{T}^h$ ,  $h \geq 2$ , that admit non-standard smooth realizations. In this paper, we show the following result: for any Liouville number  $\beta$ , the ergodic translation on the torus  $\mathbb{T}^h$  of vector  $(\beta_1, \dots, \beta_{h-1}, \beta)$  admits a non-standard smooth realization, where the  $\beta_i$ ,  $i = 1, \dots, h-1$  are chosen in a dense set of  $\mathbb{T}^{h-1}$ . More precisely, we show the following theorem:

**Theorem 1.1.** *Let  $\beta \in \mathbb{T}$  be a Liouville number,  $h \geq 2$  a positive integer. Let  $M$  be a smooth compact connected manifold of dimension  $d \geq 2$ , on which there exists an effective smooth circle action  $S_t$  preserving a positive smooth measure  $\mu$ . There exists a dense set  $E(\beta, d) \subset \mathbb{T}^{h-1}$  such that for any  $(\beta_1, \dots, \beta_{h-1}) \in E(\beta, d)$ , there is  $T \in \text{Diff}^\infty(M, \mu)$  metrically isomorphic to the ergodic translation of vector  $(\beta_1, \dots, \beta_{h-1}, \beta)$ .*

---

\*Laboratoire d'Analyse, Geometrie et Applications, Paris 13 University, 99 Avenue J.B. Clement, 93430 Villetaneuse, France. I would like to thank my advisor B. Fayad for this subject and the Centro Ennio di Giorgi, Scuola Normale Superiore de Pisa, Italy, in which part of this work was realized. Contact: mostaphabenhenda@gmail.com

To obtain this result, we explicitly construct the sequence of successive conjugacies in Anosov-Katok's periodic approximation method, with suitable estimates of their norm. Moreover, to obtain this result, we need to suitably relax one of Anosov-Katok's original assumptions.

## 1.1 Definitions

An irrational number  $\beta$  is *Liouville* if, for any  $k > 0$ , there is a sequence of integers  $q_n \rightarrow +\infty$  such that  $q_n^k \inf_{p \in \mathbb{Z}} |q_n \beta - p| \rightarrow 0$ . Liouville numbers are the complementary of Diophantine numbers in the set of irrational numbers. Let  $\mathbb{T}^h = \mathbb{R}^h / \mathbb{Z}^h$  denote the  $h$ -dimensional torus and  $\mu_h$  the Haar measure on  $\mathbb{T}^h$ . Let  $\text{Diff}^\infty(M, \mu)$  be the class of smooth diffeomorphisms of  $M$  preserving a smooth measure  $\mu$ . For  $B \in \text{Diff}^\infty(M, \mu)$  and  $j \in \mathbb{N}^*$ , let  $D^j B$  be the  $j^{\text{th}}$  derivative of  $B$  if  $j > 0$ , and the  $-j^{\text{th}}$  derivative of  $B^{-1}$  if  $j < 0$ . For  $x \in M$ , let  $|D^j B(x)|$  be the norm of  $D^j B(x)$  at  $x$ . We denote  $\|B\|_k = \max_{0 < |j| \leq k} \max_{x \in M} |D^j B(x)|$ .

A *measurable partition*  $\bar{\xi}$  of a measured manifold  $(N, \nu)$  is the equivalence class of a finite set  $\xi$  of disjoint measurable elements of  $N$  whose union is  $N$ , modulo sets of  $\nu$ -measure zero. In most of this paper, we do not distinguish a partition  $\xi$  with its equivalent class  $\bar{\xi}$  modulo sets of  $\nu$ -measure zero. In these cases, both are denoted  $\xi$ . Moreover, all the partitions considered in this paper are formed of  $\nu$ -measurable sets. The distance between two measurable partitions  $\xi$  and  $\xi'$  is defined by:

$$d(\xi, \xi') = \inf \sum_{c \in \xi, c' \in \xi'} \nu(c \Delta c')$$

A partition  $\xi'$  is *subordinate* to a partition  $\xi$  if any element of  $\xi$  is a union of elements of  $\xi'$ . In this case, if  $\mathcal{B}(\xi)$  denotes the algebra generated by  $\xi$ , then  $\mathcal{B}(\xi) \subset \mathcal{B}(\xi')$ . The inclusion map  $i : \mathcal{B}(\xi) \rightarrow \mathcal{B}(\xi')$  will be denoted  $\xi \hookrightarrow \xi'$ . This notation also means that  $\xi'$  is *subordinate* to  $\xi$ . A sequence of partitions  $\xi_n$  is *monotonic* if for any  $n$ ,  $\xi_n \hookrightarrow \xi_{n+1}$ .

A measure-preserving bijective bimeasurable map  $T : (M_1, \mu_1, \mathcal{B}_1) \rightarrow (M_2, \mu_2, \mathcal{B}_2)$  induces an *isomorphism* of measure algebras, still denoted  $T : (\mu_1, \mathcal{B}_1) \rightarrow (\mu_2, \mathcal{B}_2)$ . If  $\xi_1, \xi_2$  are partitions, and if  $\mathcal{B}_1 = \mathcal{B}(\xi_1)$  and  $\mathcal{B}_2 = \mathcal{B}(\xi_2)$ , we denote  $T : \xi_1 \rightarrow \xi_2$  this induced isomorphism of measure algebras. If  $M_1 = M_2$ ,  $\mu_1 = \mu_2$  and  $\mathcal{B}_1 = \mathcal{B}_2$ , then  $T$  is a *measure-preserving transformation*. Its induced isomorphism is an *automorphism* (see [4, p.43] and [6]).

A *metric isomorphism* of measure preserving transformations  $T_1 : (M_1, \mu_1, \mathcal{B}_1) \rightarrow (M_1, \mu_1, \mathcal{B}_1)$ ,  $T_2 : (M_2, \mu_2, \mathcal{B}_2) \rightarrow (M_2, \mu_2, \mathcal{B}_2)$  is a measure-preserving bijective bimeasurable map  $L : (M_1, \mu_1, \mathcal{B}_1) \rightarrow (M_2, \mu_2, \mathcal{B}_2)$  such that  $LT_1 = T_2L$  a.e. For convenience, when the measure is the Lebesgue measure and the algebra is the Borelian algebra, we omit to mention the measures and algebras, and we simply say that  $L : (M_1, T_1) \rightarrow (M_2, T_2)$  is a metric isomorphism.

Let  $\bar{\xi}$  be a measurable partition and  $\xi$  a representative of this equivalent class modulo sets of  $\mu$ -measure zero. For  $x \in M$ , we denote  $\xi(x)$  the element of the partition  $\xi$  such that  $x \in \xi(x)$ . A sequences of partitions  $\xi_n$  of measurable sets *generates* if there is a set of full measure  $F$  such that for any  $x \in F$ ,

$$\{x\} = F \bigcap_{n \geq 1} \xi_n(x)$$

This property of generation is independent of the choice of the representatives  $\xi_n$  of the equivalent class  $\bar{\xi}_n$  and therefore, we will say that the sequence of measurable partitions  $\bar{\xi}_n$  generates. Let  $M/\xi$  denote the equivalent class of the algebra generated by  $\xi$ , modulo sets of  $\mu$ -measure zero.  $M/\xi$  is independent of the choice of the representative  $\xi$  of the equivalent class  $\bar{\xi}$ . If  $T : M_1 \rightarrow M_2$  is a measure preserving map such that  $T(\xi_1) = \xi_2$   $\mu$ -almost everywhere, we can define a quotient map:  $T/\xi_1 : M/\xi_1 \rightarrow M/\xi_2$ .

An *effective action* of a group  $G$  on  $M$  is an action such that there is a set of full measure  $F \subset M$  such that for any  $x \in F$ , there is  $g \in G$  such that  $gx \neq x$ . When  $M = [0, 1]^{d-1} \times \mathbb{T}^1$ , we consider the periodic flow  $S_t$  defined by:

$$\begin{aligned} S_t : [0, 1]^{d-1} \times \mathbb{T}^1 &\rightarrow [0, 1]^{d-1} \times \mathbb{T}^1 \\ (x, s) &\mapsto (x, t + s \pmod{1}) \end{aligned}$$

For  $a, b \in \mathbb{T}^1$ , let  $[a, b]$  be the positively oriented circular sector between  $a$  and  $b$ , with  $a$  included and  $b$  excluded.

The *diameter*  $diam(\Gamma)$  of a domain  $\Gamma \subset M$  is defined by:  $diam(\Gamma) = \max_{x, y \in \Gamma} d(x, y)$ , where  $d(x, y)$  is the distance between  $x$  and  $y$ .

Let  $h \geq 2$  and  $\gamma = (\gamma_1, \dots, \gamma_h) \in \mathbb{Z}^h$ , with  $\gamma_i, i = 1, \dots, h$  relatively prime. Let  $\{T^{t\gamma}\}_{t \geq 0}$  a periodic flow on  $\mathbb{T}^h$ . This flow has a fundamental domain  $\Gamma \subset \mathbb{T}^{h-1} \times \{0\}$ . The boundary of  $\Gamma$  is of dimension  $h - 2$ .

For example, when  $h = 2$ , there is a fundamental domain of the flow  $\{T^{t\gamma}\}_{t \geq 0}$  that is a segment line of length  $1/\gamma_2$  (this can be seen using the Bezout identity for  $(\gamma_1, \gamma_2)$ ). Remark that the 0-volume of its boundary is equal to 2 (the 0-volume of a set of points is its cardinal).

Finally, a sequence  $T_n$  of  $\mu$ -preserving maps *weakly converges* to  $T$  if, for any measurable set  $E$ ,  $\mu(T_n E \Delta E) \rightarrow 0$ , where  $A \Delta B = (A - B) \cup (B - A)$ .

## 1.2 Basic steps of the proof

The metric isomorphism of theorem 1.1 is obtained as the limit of isomorphisms of finite algebras: indeed, we use the lemma [1, p.18]:

**Lemma 1.2.** *Let  $M_1$  and  $M_2$  be Lebesgue spaces and let  $\xi_n^{(i)}$  ( $i = 1, 2$ ) be monotonic and generating sequences of finite measurable partitions of  $M_i$ . Let  $T_n^{(i)}$  be automorphisms of  $M_i$  such that  $T_n^{(i)} \xi_n^{(i)} = \xi_n^{(i)}$  and  $T_n^{(i)} \rightarrow T^{(i)}$  in the weak topology. Suppose there are metric isomorphisms  $L_n : M_1/\xi_n^{(1)} \rightarrow M_2/\xi_n^{(2)}$  such that*

$$L_n T_n^{(1)} / \xi_n^{(1)} = T_n^{(2)} / \xi_n^{(2)} L_n$$

and

$$L_{n+1} \xi_n^{(1)} = \xi_n^{(2)}$$

then  $(M_1, T_1)$  and  $(M_2, T_2)$  are metrically isomorphic.

Said otherwise, if we have generating sequences of partitions and sequences of automorphisms  $T_n^{(i)}$  weakly converging towards  $T^{(i)}$ , and if, for any integer  $n$ , the following diagram commutes:

$$\begin{array}{ccc}
T_n^{(1)} \left( \begin{array}{c} \curvearrowright \\ \xi_n^{(1)} \\ \curvearrowleft \end{array} \right) & \xrightarrow{L_n} & \xi_n^{(2)} \left( \begin{array}{c} \curvearrowright \\ \\ \curvearrowleft \end{array} \right) T_n^{(2)} \\
\downarrow & & \downarrow \\
T_{n+1}^{(1)} \left( \begin{array}{c} \curvearrowright \\ \xi_{n+1}^{(1)} \\ \curvearrowleft \end{array} \right) & \xrightarrow{L_{n+1}} & \xi_{n+1}^{(2)} \left( \begin{array}{c} \curvearrowright \\ \\ \curvearrowleft \end{array} \right) T_{n+1}^{(2)}
\end{array}$$

then  $(M_1, T_1)$  and  $(M_2, T_2)$  are metrically isomorphic.

The proof of theorem 1.1 is in two steps. In the first step (lemma 1.3), we determine sufficient conditions on a sequence  $(T_{q_n}^{\frac{p_n}{q_n} \gamma^{(n)}})_{n \geq 0}$  of periodic translations of  $\mathbb{T}^h$  such that there exists sequences of finite partitions and automorphisms satisfying the assumptions of lemma 1.2 with  $M_1 = \mathbb{T}^h$ ,  $M_2 = M$  and  $T_n^{(1)} = T_{q_n}^{\frac{p_n}{q_n} \gamma^{(n)}}$ ,  $T_n^{(2)} = T_n$ , where  $T_n$  is also a smooth diffeomorphism, and such that the limit  $T$  in the smooth topology of the sequence  $T_n$  is smooth.

In the second step (lemma 1.5), we construct a sequence of translations  $(T_{q_n}^{\frac{p_n}{q_n} \gamma^{(n)}})_{n \geq 0}$  satisfying those conditions, such that it converges towards the translation of vector  $(\beta_1, \dots, \beta_{h-1}, \beta)$ .

**Lemma 1.3.** *There exist explicit sequences of integers  $R_1(n)$ ,  $R_2(n)$ , such that, if there exist sequences of integers  $p_n, q_n$  and  $\gamma^{(n)} = (\gamma_1^{(n)}, \dots, \gamma_h^{(n)}) \in \mathbb{Z}^h$  such that, for any integer  $n$ ,*

1. (primality)  $\gcd(\gamma_1^{(n)}, \dots, \gamma_h^{(n)}) = 1$
2. (vertical monotonicity, generation on  $M$ )  $(\gamma_h^{(n+1)} q_n)^{R_2(n)}$  divides  $q_{n+1}$
3. (horizontal monotonicity)  $\gamma_h^{(n)}$  divides  $\gamma_h^{(n+1)}$
4. (isomorphism, horizontal monotonicity for  $h \geq 3$ )  $q_n$  divides  $\gamma_1^{(n+1)} - \gamma_1^{(n)}, \dots, \gamma_h^{(n+1)} - \gamma_h^{(n)}$ .
5. (convergence of the diffeomorphism)

$$\left| \frac{p_{n+1}}{q_{n+1}} - \frac{p_n}{q_n} \right| \leq \frac{1}{(\gamma_h^{(n+1)} q_n)^{R_1(n)}}$$

6. (horizontal convergence of the partition, generation on  $\mathbb{T}^h$ ) Let  $\Gamma^{(n)} \subset \mathbb{T}^{h-1} \times \{0\}$  be a fundamental domain of the flow  $\{T^{t\gamma^{(n)}}\}$ ,  $d_n$  be the diameter of  $\Gamma^{(n)}$ , and  $\sigma_n$  the  $(h-2)$ -dimensional volume of the boundary of  $\Gamma^{(n)}$ . Then

$$d_{n+1} \leq \frac{1}{2^n \gamma_h^{(n)} \sigma_n}$$

7. (vertical convergence of the partition)

$$\sum_{n \geq 0} \frac{(\gamma_h^{(n)})^2 \sigma_n}{q_n} \left| \frac{\gamma_h^{(n+1)}}{\gamma_h^{(n+1)}} - \frac{\gamma_h^{(n)}}{\gamma_h^{(n)}} \right| < +\infty$$

then all these assumptions imply that there is  $\alpha \in \mathbb{T}^h$  such that

$$\frac{p_n}{q_n} \gamma^{(n)} \rightarrow \alpha$$

and there is a smooth ergodic measure preserving diffeomorphism  $T$  of  $M$  such that  $(\mathbb{T}^h, T^\alpha, \mu_n)$  is metrically isomorphic to  $(M, T, \mu)$ .

**Remark 1.4.** Assumption 3 is automatically derived from assumptions 2 and 4. However, the construction is easier to follow if assumption 3 is sorted out.

**Lemma 1.5.** Let  $\beta$  Liouville. There exists a dense set  $E(\beta, d) \subset \mathbb{T}^{h-1}$ , such that for any  $(\beta_1, \dots, \beta_{h-1}) \in E(\beta, d)$ , there exist sequences of integers  $p_n, q_n$  and  $\gamma^{(n)} = (\gamma_1^{(n)}, \dots, \gamma_h^{(n)}) \in \mathbb{Z}^h$  satisfying the assumptions of lemma 1.3, such that

$$\frac{p_n}{q_n} \gamma^{(n)} \rightarrow^{mod 1} (\beta_1, \dots, \beta_{h-1}, \beta)$$

We divide the proof of lemma 1.3 in three parts. In the first part of the proof, we construct a monotonic and generating partition on the  $h$ -dimensional torus  $\mathbb{T}$ , called  $\zeta_n^\infty$ , which stabilizes the translation  $T^{\frac{p_n}{q_n} \gamma^{(n)}}$ . To that end, we use assumptions 2, 3, 4, 6 and 7 (for  $h = 2$ , assumption 3 is not used and assumption 6 can be relaxed).

In the second part of the proof, we construct an isomorphism  $\tilde{K}_n^\infty$  between  $\zeta_n^\infty$  on  $\mathbb{T}^h$  and a partition  $\xi_n^\infty$  on the manifold  $M$ . In the construction of this isomorphism, assumption 4 is important. Moreover, we will see that the elements of  $\xi_n^\infty$  are not the most elementary, because they must be chosen in a way that ensures the monotonicity of the sequence  $\tilde{K}_n^\infty$ . This condition of monotonicity induces combinatorial constraints on the elements of the partition  $\xi_n^\infty$ .

In the third part of the proof, we construct diffeomorphisms  $T_n = B_n^{-1} S^{\frac{p_n}{q_n}} B_n$  on  $M$  stabilizing  $\xi_n^\infty$ , obtained by successive conjugations from the rotation  $S^{\frac{p_n}{q_n}}$ . The conjugacy  $B_n$  is constructed explicitly. This is a major difference with Anosov-Katok's original construction [1]. Ours rather elaborates upon the work of [3]. Our construction provides suitable estimates of the norm of the conjugacy  $\|B_n\|_n$  (an estimate that is a polynomial function of  $q_{n-1} \gamma_h^{(n)}$ ). Combined with condition 5, these estimates ensure the convergence of the sequence of diffeomorphisms  $T_n$ .

A second substantive difference with Anosov-Katok's original work is condition 5: contrary to [1], we do not require the numbers  $p_n$  and  $q_n$  to be relatively prime. Thus, we obtain a larger limit set of numbers. This assumption of relative primality was not really needed in Anosov-Katok's original construction.<sup>1</sup> In order to obtain the convergence of the sequence of diffeomorphisms  $T_n$ , and the ergodicity of its limit  $T$ , it suffices to require that  $p_{n+1}/q_{n+1}$  and  $p_n/q_n$  are close enough. To obtain ergodicity, we slightly modify Anosov-Katok's argument (they kept  $p_n$  and  $q_n$  relatively prime to get ergodicity).

Thus, contrary to Anosov-Katok's construction, elements of the partitions  $\zeta_n^\infty$  and  $\xi_n^\infty$  are not fundamental domains of  $T^{\frac{p_n}{q_n} \gamma^{(n)}}$  and  $T_n$ , respectively. Instead, fundamental domains of these transformations are obtained as unions of elements of those partitions. In other words, we "de-maximize" partitions to the extent permitted by condition 5.

<sup>1</sup>On the other hand, though the assumption  $\gcd(\gamma_1^{(n)}, \dots, \gamma_h^{(n)}) = 1$  is not necessary, relaxing this assumption does not lead to something interesting. Indeed, condition 6 requires a control of the speed of growth of  $\gcd(\gamma_1^{(n)}, \dots, \gamma_h^{(n)})$ . Moreover, the explicit construction of the limit translation keeps constant this gcd. Therefore, "de-maximizing" in the  $\gamma_i^{(n)}$  does not seem to improve the result.

This generalization is the same as in [3], except that these authors do not present it in this way.

First, we prove lemma 1.5.

### 1.3 Proof of lemma 1.5

First, we show the existence of one translation with  $\beta$  at the  $h^{\text{th}}$  coordinate. Second, we show the density for the  $h-1^{\text{th}}$  first coordinates. This will prove lemma 1.5. Moreover, to show the existence of one translation, we first tackle the case of  $h = 2$ , simpler to write and read. Then, we consider the general case  $h \geq 2$ .

#### 1.3.1 Proof of the existence of one translation for $h = 2$

We divide the proof of the case  $h = 2$  in three steps. Let  $\beta$  be a Liouville number. First, let  $P(n) = 5R_1(n) + 4R_1(n)R_2(n)$ . Since  $\beta$  is Liouville, we can find a sequence  $p'_n, q'_n$  such that  $p'_0 = 0, q'_0 = 1$ , such that for  $n \geq 1, q'_n \geq q'_{n-1}{}^{4+2R_2(n-1)}$  and such that:

$$\left| \beta - \frac{p'_n}{q'_n} \right| \leq \frac{1}{2q'_n{}^{P(n)}} \quad (1)$$

The second step is based on the following claim:

**Claim 1.6.** *There exists sequences  $\gamma_1^{(n)}, \gamma_2^{(n)}, q_n$  such that for any  $n$ :*

(i)  $q'_n \geq \gamma_2^{(n)}$  and  $q'_n \geq q_{n-1}$

(ii)  $q_n = q'_n(q_{n-1}\gamma_2^{(n)})^{R_2(n)}$

(iii)  $\gamma_1^{(n)}$  and  $\gamma_2^{(n)}$  are relatively prime

*Proof.* We proceed by induction. Let  $q_0 = \gamma_1^{(0)} = \gamma_2^{(0)} = 1$  and suppose that  $\gamma_2^{(n)}, q_n$  are constructed. Let us define  $\gamma_2^{(n+1)}, q_{n+1}$ : by the Bezout theorem, since  $\gamma_1^{(n)}$  and  $\gamma_2^{(n)}$  are relatively prime, there are  $m_{1,n}, m_{2,n}$  such that  $m_{1,n}\gamma_2^{(n)} - m_{2,n}\gamma_1^{(n)} = 1$ . Moreover, we can take  $0 < m_{2,n} \leq (\gamma_2^{(n)})^2$  (for this upper bound, any  $(\gamma_2^{(n)})^p$ , with  $p \geq 1$  a fixed function of  $n$  would work).

Let  $\gamma_1^{(n+1)} = \gamma_1^{(n)} + m_{1,n}q_n$  and  $\gamma_2^{(n+1)} = \gamma_2^{(n)} + m_{2,n}q_n$ . Then  $\gamma_1^{(n+1)}$  and  $\gamma_2^{(n+1)}$  satisfy a Bezout equation and therefore, they are relatively prime. Moreover, since  $R_2(n-1) \leq R_2(n)$ ,

$$q'_{n+1} \geq q_n^{1+2R_2(n)} \geq q_n$$

and

$$\gamma_2^{(n+1)} \leq \gamma_2^{(n)} + (\gamma_2^{(n)})^2 q_n \leq q'_n + q_n^{3+2R_2(n)} \leq q_n^{4+2R_2(n)} \leq q'_{n+1}$$

We have thus completed the construction at rank  $n + 1$ . □

By claim 1.6, conditions 1, 2, 3 hold. Moreover, by construction,  $\gamma_1^{(n+1)}$  and  $\gamma_2^{(n+1)}$  satisfy condition 4 of lemma 1.3. Moreover, conditions 6 and 7 of lemma 1.3 automatically hold: indeed, by property (ii), and since  $m_{2,n} > 0$ , then  $\gamma_2^{(n+1)} \geq 2^n \gamma_2^{(n)}$  and therefore,

$$\frac{1}{\gamma_2^{(n+1)}} \leq \frac{1}{2^n \gamma_2^{(n)}}$$

hence condition 6 (indeed, when  $\gcd(\gamma_1, \gamma_2) = 1$ , the diameter of the fundamental domain of the translation of vector  $(\gamma_1, \gamma_2)$  is  $1/\gamma_2$ ).

To obtain 7, note that since

$$\frac{\gamma_1^{(n+1)}}{\gamma_2^{(n+1)}} - \frac{\gamma_1^{(n)}}{\gamma_2^{(n)}} = \frac{q_n}{(\gamma_2^{(n)})^2(1 + m_{2,n}q_n/\gamma_2^{(n)})}$$

and since, by (ii),  $q_n/\gamma_2^{(n)} \geq 2^n$ , then

$$\left| \frac{\gamma_1^{(n+1)}}{\gamma_2^{(n+1)}} - \frac{\gamma_1^{(n)}}{\gamma_2^{(n)}} \right| \leq \frac{q_n}{(\gamma_2^{(n)})^2 2^n} \quad (2)$$

hence condition 7.

It remains to obtain condition 5. We define  $p_n$  recursively by:  $p_0 = 0$  and:

$$p_{n+1} = \frac{q_{n+1}}{\gamma_2^{(n+1)}} \left( \frac{p'_{n+1}}{q'_{n+1}} - \frac{p'_n}{q'_n} \right) + \frac{q_{n+1}}{q_n} p_n \quad (3)$$

Given the definitions of  $q_{n+1}$  and  $\gamma_2^{(n+1)}$ ,  $p_{n+1}$  is an integer. Let us check condition 5. By estimate (1), we have:

$$\left| \frac{p_{n+1}}{q_{n+1}} - \frac{p_n}{q_n} \right| \leq \frac{2}{q_n'^{P(n)} \gamma_2^{(n+1)}}$$

Moreover, by (ii) of claim 1.6,

$$(\gamma_2^{(n+1)} q_n)^{R_1(n)} \leq (q_n'^{5+4R_2(n)})^{R_1(n)} \leq q_n'^{P(n)}$$

Therefore,

$$q_n'^{P(n)} \gamma_2^{(n+1)} \geq (\gamma_2^{(n+1)} q_n)^{R_1(n)}$$

Hence condition 5.

Moreover, by condition 4 (a condition that holds, as shown above), we have, modulo 1:

$$\frac{p_{n+1}}{q_{n+1}} \gamma_2^{(n+1)} - \frac{p_n}{q_n} \gamma_2^{(n)} \equiv_{\text{mod} 1} \left( \frac{p_{n+1}}{q_{n+1}} - \frac{p_n}{q_n} \right) \gamma_2^{(n+1)} = \frac{p'_{n+1}}{q'_{n+1}} - \frac{p'_n}{q'_n}$$

By summing this equality, since  $p_0 = p'_0 = 0$ , we obtain that

$$\frac{p_n}{q_n} \gamma_2^{(n)} \rightarrow_{\text{mod} 1} \beta$$

Likewise,

$$\frac{p_{n+1}}{q_{n+1}} \gamma_1^{(n+1)} - \frac{p_n}{q_n} \gamma_1^{(n)} \equiv_{\text{mod} 1} \left( \frac{p_{n+1}}{q_{n+1}} - \frac{p_n}{q_n} \right) \gamma_1^{(n+1)} = \frac{\gamma_1^{(n+1)}}{\gamma_2^{(n+1)}} \left( \frac{p'_{n+1}}{q'_{n+1}} - \frac{p'_n}{q'_n} \right)$$

Moreover, by estimation (2),



$$\left| \frac{\gamma_1^{(n+1)}}{\gamma_2^{(n+1)}} \right| \leq \frac{q_n}{2^n} \leq \frac{q_n'^{1+2R_2(n)}}{2^n} \leq \frac{1}{2^n \left| \frac{p'_{n+1}}{q'_{n+1}} - \frac{p'_n}{q'_n} \right|}$$

Therefore,  $\sum_{n \geq 0} \frac{\gamma_1^{(n+1)}}{\gamma_2^{(n+1)}} \left( \frac{p'_{n+1}}{q'_{n+1}} - \frac{p'_n}{q'_n} \right)$  converges, and

$$\frac{p_n}{q_n} \gamma_1^{(n)} \rightarrow_{\text{mod } 1} \sum_{n \geq 0} \frac{\gamma_1^{(n+1)}}{\gamma_2^{(n+1)}} \left( \frac{p'_{n+1}}{q'_{n+1}} - \frac{p'_n}{q'_n} \right)$$

Hence the existence of one translation for  $h = 2$ .

**Remark 1.7.** *The proof above also gives that:*

$$\frac{p_n}{q_n} \rightarrow_{\text{mod } 1} \sum_{n \geq 0} \frac{1}{\gamma_2^{(n+1)}} \left( \frac{p'_{n+1}}{q'_{n+1}} - \frac{p'_n}{q'_n} \right)$$

### 1.3.2 Proof of the existence of one translation for $h \geq 2$

For  $h \geq 2$ , the proof of the theorem is a little more intricate, though the main scheme is the same: we still need estimation (1) (with another function  $T(n)$ ) and equation (3).

To the vector space  $\mathbb{R}^h$ , we give the norm  $\|(x_1, \dots, x_h)\| = \max_{1 \leq i \leq h} |x_i|$  and we consider its induced norm on  $\mathbb{T}^h$ .

We seek  $\gamma^{(n+1)}$  in the form:

$$\gamma^{(n+1)} = q_n v_1 + (c q_n + 1) \gamma^{(n)}$$

with  $v_1 \in \mathbb{Z}^h$  and  $c \in \mathbb{N}$ .

Thus,  $q_n$  always divides  $\gamma_i^{(n+1)} - \gamma_i^{(n)}$  for any  $i = 0, \dots, h-1$ , and condition 4 of lemma 1.3 always obtains. Likewise, since  $\gamma_h^{(n)}$  divides  $q_n$ , then  $\gamma_h^{(n)}$  divides  $\gamma_h^{(n+1)}$  and condition 3 also obtains.

To get condition 1 of relative primality, we add assumptions on  $v_1$ : we consider it of the form  $v_1 = A v_2$ , with  $v_{2,h} = 0$ , and with the  $v_{2,i}$ ,  $i = 0, \dots, h-1$  relatively prime ( $v_{2,i}$  is the  $i^{\text{th}}$  coordinate of  $v_2$ ). Moreover,  $A \in \text{SL}(h, \mathbb{Z})$  is such that its last column is  $\gamma^{(n)}$ .

Indeed, such matrix  $A$  exists by corollary 1.9 below, and these assumptions on  $v_2$  imply condition 1, because  $\text{SL}(h, \mathbb{Z})$  stabilizes the set of integer vectors with relatively prime coordinates. Let  $\gamma$  be a vector. A quantity  $Q(\gamma)$  is *polynomially controlled* in  $\gamma$  if there is a polynomial function  $P$  such that  $|Q(\gamma)| \leq P(|\gamma|)$ . Corollary 1.9 is well-known, but we recall it to highlight the polynomial control in  $\gamma$ . To prove corollary 1.9, we need the following lemma:

**Lemma 1.8.** *Let  $\gamma_1, \dots, \gamma_h \in \mathbb{Z}$  such that  $\gcd(\gamma_1, \dots, \gamma_h) = d > 0$ . Then there exists a matrix  $T \in \text{SL}(h, \mathbb{Z})$  polynomially controlled in the norm of  $\gamma = (\gamma_1, \dots, \gamma_h)$  such that  $T(\gamma_1, \dots, \gamma_h) = (d, 0, \dots, 0)$ . More precisely we have:*

$$\|T\| \leq h^{h-1} \|\gamma\|^{h-1}$$

*Proof.* We proceed by induction on  $h$ . For  $h = 1$ , the lemma is obvious. Suppose it true for  $h-1$ . Let  $d' = \gcd(\gamma_1, \dots, \gamma_{h-1})$ . By the induction assumption, there is  $T' \in \text{SL}(h-1, \mathbb{Z})$  polynomially controlled in  $\gamma$  such that  $T'(\gamma_1, \dots, \gamma_{h-1}) = (d', 0, \dots, 0)$ . Let

$$\tilde{T} = \begin{pmatrix} T' & 0 \\ 0 & 1 \end{pmatrix}$$

Then  $\tilde{T}(\gamma_1, \dots, \gamma_{h-1}) = (d', 0, \dots, 0, \gamma_h)$

Let  $-\gamma_h^2 - d'^2 \leq m_1, m_2 \leq \gamma_h^2 + d'^2$  such that  $m_1 d' + m_2 \gamma_h = d$ . Let

$$T_h = \begin{pmatrix} m_1 & 0 & \cdots & 0 & m_2 \\ 0 & 1 & 0 & \cdots & 0 \\ \vdots & \ddots & \ddots & \ddots & \vdots \\ 0 & \cdots & 0 & 1 & 0 \\ \gamma_h/d & 0 & \cdots & 0 & -d'/d \end{pmatrix}$$

We have that  $T_h \in \text{SL}(h, \mathbb{Z})$  and  $T_h(d', 0, \dots, 0, \gamma_h) = (d, 0, \dots, 0)$ . If we let  $T = T_h \tilde{T}$  then we obtain the property at rank  $h$ . □

**Corollary 1.9.** *If  $\text{gcd}(\gamma_1, \dots, \gamma_h) = 1$ , then there exists  $A \in \text{SL}(h, \mathbb{Z})$  polynomially controlled in  $\gamma$  such that  $Ae_h = (\gamma_1, \dots, \gamma_h)$ .*

*Proof.* Modulo a permutation of coordinates (which is an application of a permutation matrix, i.e. an isometry), it suffices to show that there is a matrix  $A \in \text{SL}(h, \mathbb{Z})$  polynomially controlled in  $\gamma$  such that  $Ae_1 = (\gamma_1, \dots, \gamma_h)$ . By lemma 1.8, there is a matrix  $B \in \text{SL}(h, \mathbb{Z})$  polynomially controlled in  $\gamma$  such that  $e_1 = B(\gamma_1, \dots, \gamma_h)$ . Let  $A = B^{-1}$ . Then  $A = \frac{\pm}{\pm} {}^t \text{com}(B)$ , where  ${}^t \text{com}(B)$  is the transposition of the comatrix of  $B$ . By the Cramer formula,  $\|A\|$  is polynomially controlled by  $\|B\|$ . Hence corollary 1.9. □

We obtain conditions 6 and 7 of lemma 1.3 with a suitable choice of  $v_2$  and  $c$ , and to obtain 5, it suffices to show that  $v_2$  and  $c$  are bounded by a fixed polynomial of  $q_n, \gamma_h^{(n)}$ . We first choose  $v_2$ , then we choose  $c$ .

Condition 7 is the most easy to obtain. Indeed, we have:

$$\frac{\gamma^{(n+1)}}{\gamma_h^{(n+1)}} - \frac{\gamma^{(n)}}{\gamma_h^{(n)}} = \frac{q_n v_1 + (c q_n + 1) \gamma^{(n)}}{q_n v_{1,h} + (c q_n + 1) \gamma_h^{(n)}} - \frac{\gamma^{(n)}}{\gamma_h^{(n)}} = \frac{q_n v_1 \gamma_h^{(n)} - q_n v_{1,h} \gamma^{(n)}}{\gamma_h^{(n)} (q_n v_{1,h} + (c q_n + 1) \gamma_h^{(n)})} \quad (4)$$

The parameter  $\sigma_n$  is a fixed polynomial in  $\gamma^{(n)}$ . Therefore, there exists an integer-valued function  $R_3(n)$  such that if  $c \geq (\gamma_h^{(n)} q_n)^{R_3(n)}$ , then condition 7 obtains.

It remains to obtain 5 and 6. Let  $E \subset F \subset \mathbb{T}^h$ . The set  $E$  is a  $\delta$ -net of  $F$  if there is  $\Gamma \subset \mathbb{T}^h$  such that  $\text{diam } \Gamma \leq \delta$  and

$$F \subset \bigcup_{e \in E} e + \Gamma$$

To obtain 5 and 6, it suffices to show that, for any integer  $p > 1$ , we can find a vector  $v_2 \in \mathbb{Z}^{h-1} \times 0$  and a parameter  $c \in \mathbb{N}$  such that  $\|v_2\|$  and  $c$  are polynomially controlled by  $p$  and, such that the orbit of 0 by the periodic flow  $T^{t\gamma^{(n+1)}}$  is a  $1/p$ -net of  $\mathbb{T}^h$ .

To show this fact, we first show the proposition:

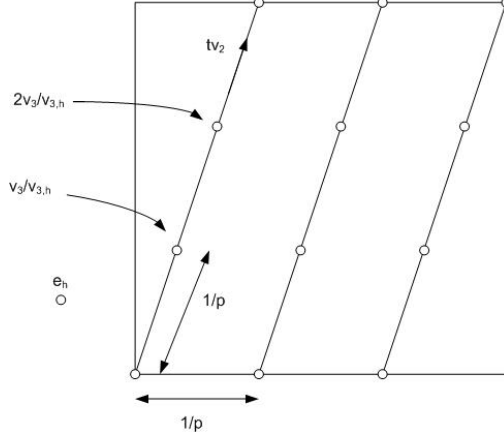

Figure 1: The small circles represent the intersections of  $tv_3$  with  $\mathbb{T}^{h-1} \times \{0\}$

**Proposition 1.10.** *We can choose  $v_2 \in \mathbb{Z}^{h-1}$  polynomially controlled by  $p$  such that  $T^{tv_2}$  intersects any square of sidelength  $1/p$ .*

*Proof.* Let  $(x_1, \dots, x_{h-1}) \in \mathbb{T}^{h-1}$ . There are integers  $l_1, \dots, l_{h-1}$  such that

$$C = \prod_{i=1}^{h-1} \left[ \frac{l_i}{2p}, \frac{l_i}{2p} + \frac{1}{2p} \right] \subset \prod_{i=1}^{h-1} \left[ x_i, x_i + \frac{1}{p} \right]$$

It suffices to show that we can find  $t \in \mathbb{R}$  and  $v_2$  polynomially controlled by  $p$  such that  $tv_2 \in C$ . Let  $s = 4(h-2)p$  and  $v_2 = (s^{h-2}, s^{h-3}, \dots, 1)$ .  $v_2$  is polynomially controlled by  $p$ . Let  $k_i = (h-2)(2l_i + 1)$ , and

$$t = \frac{1}{s^{h-2}} \left( \frac{k_1}{s} + k_2 + \dots + k_{h-1} s^{h-3} \right)$$

Let  $u = (k_1/s, \dots, k_{h-1}/s)$ . Then  $\|tv_2 - u\| \leq 1/(4p)$  and

$$u \in \prod_{i=1}^{h-1} \left[ \frac{2l_i + 1}{4p} - \frac{1}{4p}, \frac{2l_i + 1}{4p} + \frac{1}{4p} \right] = C$$

Therefore,  $tv_2 \in C$ . □

Let  $v_3 = q_n v_2 + (cq_n + 1)e_h$ . For a given choice of  $c$  sufficiently large, but still polynomially controlled by  $p$ ,  $(tv_3)_{t \geq 0}$  intersects  $\mathbb{T}^{h-1} \times \{0\}$  in a  $1/p$ -net (see figure 1).

Let  $b_1, \dots, b_{h-1}$  such that the hyperplane  $A^{-1}(\mathbb{R}^{h-1} \times \{0\})$  has an equation of the form  $x_h = \sum_{i=1}^{h-1} b_i x_i$ . Let  $b = \max(1, b_1, \dots, b_{h-1})$ .  $b$  is polynomially controlled by  $\|A^{-1}\|$  (which is itself polynomially controlled by  $\|\gamma^{(n)}\|$ , see corollary 1.9). Then the orbit of 0 by  $T^{v_3}$  intersects  $A^{-1}(\mathbb{T}^{h-1} \times \{0\})$  in a  $\delta_A$ -net with  $\delta_A \leq 2b/p$  (see figure 2).

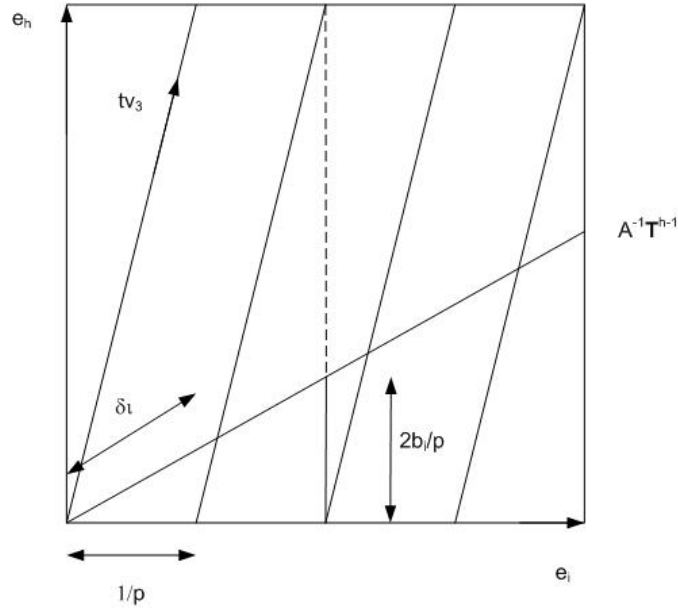

Figure 2: The flow  $tv_3$  in the plan  $(e_i, e_n)$ ,  $1 \leq i \leq h-1$

Finally, by applying the matrix  $A$ , we get that the orbit of 0 by  $T^{tAv_3} = T^{t\gamma^{(n+1)}}$  intersects  $\mathbb{T}^{h-1} \times \{0\}$  in a  $2b\|A\|/p$ -net. This completes the proof of the existence of one translation with  $\beta$  being the  $h^{\text{th}}$  coordinate of this translation.

The limit translations are of the form  $(\beta_1, \dots, \beta_{h-1}, \beta)$  with for any  $i = 0, \dots, h-1$ :

$$\beta_i = \sum_{n \geq 0} \frac{\gamma_i^{(n+1)}}{\gamma_h^{(n+1)}} \left( \frac{p'_{n+1}}{q'_{n+1}} - \frac{p'_n}{q'_n} \right)$$

Moreover, the rotation number  $\beta_0 \in E_0(\beta)$  of the diffeomorphism  $T$  on  $M$  is of the form:

$$\beta_0 = \sum_{n \geq 0} \frac{1}{\gamma_h^{(n+1)}} \left( \frac{p'_{n+1}}{q'_{n+1}} - \frac{p'_n}{q'_n} \right)$$

### 1.3.3 Proof of the density of the limit translations for $h \geq 2$

We directly tackle the case  $h \geq 2$ . We follow and slightly modify the previous proof. Let  $\epsilon > 0$  and  $\alpha_1, \dots, \alpha_{h-1} \in \mathbb{T}$ .

In relation (1), we can take a fixed function  $T(n)$  such that we will have, for  $n \geq 1$ ,

$$\left| \beta - \frac{p'_n}{q'_n} \right| \leq \frac{\epsilon}{q_n 2^n}$$

This fixes  $p'_1$  and  $q'_1$  (but it does not fix the other  $p'_n, q'_n$ ,  $n \geq 1$ , because  $q_n$  depends on  $\gamma_h^{(n)}$ ). Moreover, we can take  $p'_1 > 0$ .

For  $i = 1, \dots, h-1$ , let  $\gamma_i^{(0)}$  and  $\gamma_h^{(0)}$  such that

$$\left| \frac{\gamma_i^{(0)}}{\gamma_h^{(0)}} - \frac{q'_1 \alpha_i}{p'_1} \right| \leq \epsilon \frac{q'_1}{p'_1}$$

In relation (4), for  $n = 0$ , let  $c$  be sufficiently large such that

$$\left| \frac{\gamma_i^{(1)}}{\gamma_h^{(1)}} - \frac{\gamma_i^{(0)}}{\gamma_h^{(0)}} \right| \leq \epsilon \frac{q'_1}{p'_1}$$

Therefore,

$$\left| \frac{p'_1 \gamma_i^{(1)}}{q'_1 \gamma_h^{(1)}} - \alpha_i \right| \leq 2\epsilon \quad (5)$$

For each  $n \geq 1$ , we also take  $c$  sufficiently large so that

$$\left| \frac{\gamma_i^{(n+1)}}{\gamma_h^{(n+1)}} \right| \leq q_n + \frac{\gamma_i^{(0)}}{\gamma_h^{(0)}} \leq q_n + \epsilon \frac{q'_1}{p'_1} + \alpha_i \frac{q'_1}{p'_1} \leq 4q_n$$

Therefore,

$$\sum_{n \geq 1} \frac{\gamma_i^{(n+1)}}{\gamma_h^{(n+1)}} \left( \frac{p'_{n+1}}{q'_{n+1}} - \frac{p'_n}{q'_n} \right) \leq \sum_{n \geq 1} \frac{\epsilon}{2^{n-2}} = 8\epsilon$$

By combining this estimation with (5), we finally obtain:

$$\left| \sum_{n \geq 0} \frac{\gamma_i^{(n+1)}}{\gamma_h^{(n+1)}} \left( \frac{p'_{n+1}}{q'_{n+1}} - \frac{p'_n}{q'_n} \right) - \alpha_i \right| \leq 10\epsilon$$

Hence the density of the limit translations.

Let us make two remarks. First, with our method, we cannot obtain substantially more translations, because the isomorphism condition 4 is constraining. Indeed, this condition introduces arithmetical constraints on the sequences  $\gamma_i^{(n)}$ , which limit the set of possible translations. We can interpret this limitation heuristically. On the manifold  $M$ , we only have one degree of freedom for the associated diffeomorphism  $T$ : the angle of the conjugating rotation. The isomorphism condition transfers this one-dimensional constraint to the multi-dimensional setting of the torus: although translations have  $h \geq 2$  dimensions, they only have one single "effective" degree of freedom.

Second, the set  $E_0(\beta)$  of possible rotation numbers  $\beta_0$  for the diffeomorphism  $T$  on  $M$  is infinite, and accumulates 0. We can note the following phenomenon: with our method, the closer we want to approximate a given irrational number  $\alpha_i$  on the  $i^{\text{th}}$  coordinate,  $i = 0, \dots, h-1$ , the smaller  $\beta_0$  becomes, because  $\gamma_h^{(1)}$  has to be taken large.

The rest of the paper is dedicated to the proof of lemma 1.3.

## 2 Partitions of the torus

The aim of this section is to show the following proposition:

**Proposition 2.1.** *If assumptions 2, 3, 4, 6 and 7 of lemma 1.3 hold, there exists measurable partitions  $(\zeta_n^m)_{n \geq 0, n < m}$  of  $\mathbb{T}^h$ , such that  $\zeta_n^m$  is stable by the translation  $T^{\frac{m}{q_n} \gamma^{(n)}}$ , and such that at  $m$  fixed, for  $n < m$ ,  $\zeta_{n+1}^m \hookrightarrow \zeta_n^m$ .*

*Moreover, at  $n$  fixed,  $\zeta_n^m$  converges as  $m \rightarrow +\infty$  towards a partition  $\zeta_n^\infty$ , stable by the translation  $T^{\frac{\gamma^{(n)}}{q_n}}$ . Moreover, the sequence  $(\zeta_n^\infty)_{n \geq 0}$  is monotonous and generates.*

Proposition 2.1 is given by the combination of lemma 2.2 and 2.4. In all the paper, we denote  $r_n = q_n / \gamma_h^{(n)}$ ,  $k_n = \gamma_h^{(n+1)} / \gamma_h^{(n)}$ . They are integers by assumption.

A natural partition stabilizing the translation  $T^{\frac{\gamma^{(n)}}{q_n}}$  is given by (see figure 3):

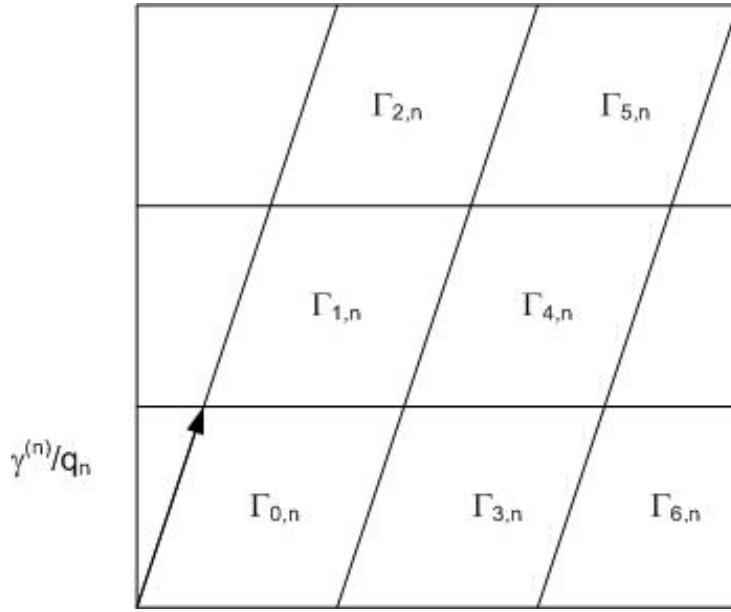

Figure 3: The natural partition  $\zeta_n$

$$\zeta_n = \{\Gamma_{k,n} = T^{\frac{k}{q_n} \gamma^{(n)}} \Gamma_{0,n}, 0 \leq k \leq q_n - 1\}$$

where

$$\Gamma_{0,n} = \bigcup_{0 \leq t \leq \frac{1}{q_n}} \Gamma^{(n)}$$

and  $\Gamma^{(n)} \subset \mathbb{T}^{h-1}$  is a fundamental domain of the flow  $T^{t\gamma^{(n)}}$ .

Remember that in order to apply lemma 1.2, we need a monotonous sequence of partitions. Moreover, in our theorem, we need the limit translation to be ergodic. However, note that if we take  $\gamma^{(n+1)}$  and  $\gamma^{(n)}$  not parallel, then the sequence of  $\zeta_n$  cannot be monotonous. On the contrary, if we take  $\gamma^{(n+1)}$  parallel to  $\gamma^{(n)}$ , then the limit translation cannot be ergodic: any band of the form

$$\bigcup_{t \geq 0} T^{t\gamma^{(n)}} B$$

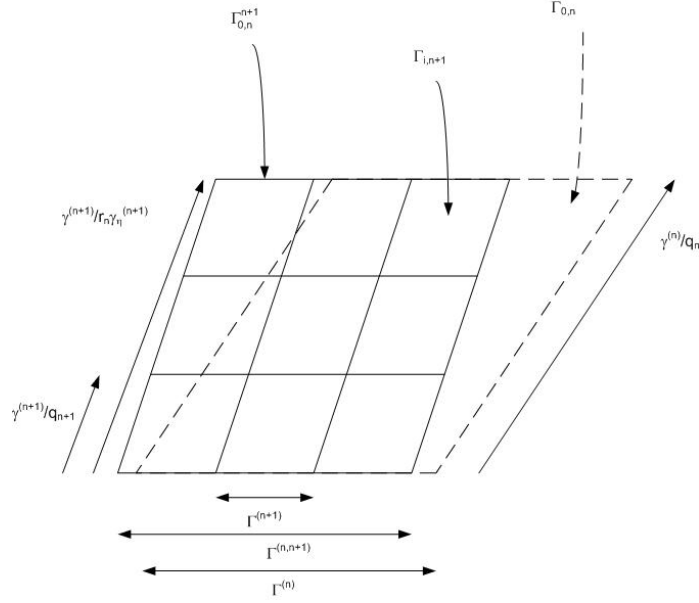

Figure 4: The modified partition  $\zeta_n^{n+1}$

where  $B \subset \mathbb{T}^{h-1}$ , and  $0 < \text{diam} B < \text{diam} \Gamma^{(n)}$ , is invariant by the flow  $T^{r\gamma^{(n)}}$ , and thus invariant by any translation included in this flow.

Therefore, we must take another partition. We obtain it by "monotonizing"  $\zeta_n$ . We begin with an informal description of the construction. This "monotonization" is performed in three steps: in the first step, we construct a partition  $\zeta_n^{n+1}$  stable by the translation  $T^{\frac{p_n}{q_n} \gamma^{(n)}}$  and such that  $\zeta_n^{n+1} \hookrightarrow \zeta_{n+1}$  (figure 4).

In the second step, we iterate this procedure, so as to obtain a partition  $\zeta_n^m$ , such that  $\zeta_n^m \hookrightarrow \zeta_m$ . Thus, the element  $\Gamma_{k,n}^m$  of  $\zeta_n^m$  is a "pixelisation" of  $\Gamma_{k,n}$  with a resolution  $m$ . At  $m$  fixed, for  $n < m$ ,  $\zeta_{n+1}^m \hookrightarrow \zeta_n^m$ . These two steps are performed by lemma 2.2

In the third step, we take the limit  $m \rightarrow +\infty$ , which exists because of conditions 6 and 7. This gives a partition  $\zeta_n^\infty$  endowed with the required properties: monotonicity, generation and stability by the translation  $T^{\frac{p_n}{q_n} \gamma^{(n)}}$ .

**Lemma 2.2.** *If assumptions 2, 3 and 4 of lemma 1.3 hold, there exists measurable partitions  $(\zeta_n^m)_{n \geq 0, n < m}$  of  $\mathbb{T}^h$ , such that  $\zeta_n^m$  is stable by the translation  $T^{\frac{p_n}{q_n} \gamma^{(n)}}$ , and such that at  $m$  fixed, for  $n < m$ ,  $\zeta_{n+1}^m \hookrightarrow \zeta_n^m$ .*

*Proof.* We denote:

$$\zeta_n' = \left\{ \Gamma_{k,n}' = T^{k \frac{\gamma^{(n)}}{\gamma_h^{(n)}}} \Gamma^{(n)}, k = 0, \dots, \gamma_h^{(n)} - 1 \right\}$$

Notice that  $T^{\frac{\gamma^{(n)}}{\gamma_h^{(n)}}$  can be seen as a translation of  $\mathbb{T}^{h-1}$ , and  $\zeta_n'$  as a partition of  $\mathbb{T}^{h-1}$ . Let

$$K = \left\{ 0 \leq k < \gamma_h^{(n+1)} \text{ such that } k \frac{\gamma^{(n+1)}}{\gamma_h^{(n+1)}} \in \Gamma^{(n)} \right\}$$

Note that  $|K| = k_n$ . We define (see figure 5):

$$\Gamma^{(n,n+1)} = \bigcup_{k \in K} \Gamma'_{k,n+1}$$

We have the lemma:

**Lemma 2.3.** *Under the assumptions 2, 3 and 4 of lemma 1.3,  $\Gamma^{(n,n+1)}$  is a fundamental domain of  $T^{\frac{\gamma^{(n)}}{\gamma_h^{(n)}}}$ , seen as a translation of  $\mathbb{T}^{h-1}$ .*

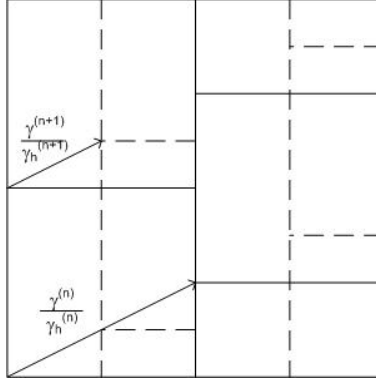

Figure 5: Partitions  $z'_n$  (solid lines) and  $z'_{n+1}$  (dashed lines) on  $\mathbb{T}^{h-1}$  for  $h = 3$ ,  $\gamma^{(n)} = (2, 1, 4)$  and  $\gamma^{(n+1)} = (2, 1, 8)$ . This example does not satisfy condition 6 of lemma 1.3, but it was chosen for illustrative purposes. To satisfy condition 6, we can take instead  $\gamma^{(n+1)} = (2, 9, 72)$  and  $n = 0$ . Indeed, in this case,  $d_1 = 1/8$  and  $\sigma_0 = 2$ .

*Proof.* Let  $V^{(n)} = T^{\frac{\gamma^{(n)}}{\gamma_h^{(n)}}}$ . By assumptions 2 and 4 of lemma 1.3,  $V^{(n)} = T^{\frac{\gamma^{(n+1)}}{\gamma_h^{(n+1)}}}$ . By assumptions 3 and 4,  $(V^{(n+1)})^{k_n} = V^{(n)}$ . For  $u = 0, \dots, \gamma_h^{(n)} - 1$ , let

$$K_u = \{l, 0 \leq l \leq \gamma_h^{(n+1)} - 1, (V^{(n+1)})^l(0) \in \Gamma'_{u,n}\}$$

Note that  $K_0 = K$  and that  $\{K_u, u = 0, \dots, \gamma_h^{(n)} - 1\}$  is a partition of  $\{0, \dots, \gamma_h^{(n+1)} - 1\}$ . Note also that  $l \in K_u$  if and only if  $l - k_n u \in K$ . We denote  $A \sqcup B$  the disjoint union of  $A$  and  $B$ . We have:

$$\begin{aligned} \mathbb{T}^{h-1} &= \bigsqcup_{l=0}^{\gamma_h^{(n+1)}-1} (V^{(n+1)})^l \Gamma^{(n+1)} = \bigsqcup_{u=0}^{\gamma_h^{(n)}-1} \bigsqcup_{l \in K_u} (V^{(n+1)})^l \Gamma^{(n+1)} = \bigsqcup_{u=0}^{\gamma_h^{(n)}-1} \bigsqcup_{t \in K} (V^{(n+1)})^{t+k_n u} \Gamma^{(n+1)} \\ &= \bigsqcup_{u=0}^{\gamma_h^{(n)}-1} (V^{(n+1)})^{k_n u} \Gamma^{(n,n+1)} = \bigsqcup_{u=0}^{\gamma_h^{(n)}-1} (V^{(n)})^u \Gamma^{(n,n+1)} \end{aligned}$$

Therefore,  $\Gamma^{(n,n+1)}$  is a fundamental domain of  $T^{\frac{\gamma^{(n)}}{\gamma_h^{(n)}}}$ . □



We define (see figure 4):

$$\Gamma_{q_n}^{(n,n+1)} = \bigcup_{0 \leq t < \frac{1}{n\gamma_h^{(n+1)}}} T^{t\gamma^{(n+1)}} \Gamma^{(n,n+1)}$$

Since  $r_n \gamma_h^{(n+1)} = k_n q_n$  divides  $q_{n+1}$ , then  $\Gamma_{q_n}^{(n,n+1)}$  is composed of elements of  $\zeta_{n+1}$ . Moreover,  $\Gamma_{q_n}^{(n,n+1)}$  has the same height as  $\Gamma_{k,n}$  by condition 2. Therefore, by lemma 2.3,  $\Gamma_{q_n}^{(n,n+1)}$  is also a fundamental domain of  $T^{\frac{\gamma^{(n)}}{q_n}}$ . Let

$$\zeta_n^{n+1} = \{\Gamma_{k,n}^{n+1} = T^{k\frac{\gamma^{(n)}}{q_n}} \Gamma_{q_n}^{(n,n+1)}, k = 0, \dots, q_n - 1\}$$

We have  $\zeta_n^{n+1} \hookrightarrow \zeta_{n+1}$ . Let

$$Q_n^{n+1} \Gamma_{k,n} = \Gamma_{k,n}^{n+1}$$

and for  $m > n$ ,

$$Q_n^m = Q_{m-1}^m \cdots Q_n^{n+1}$$

The map  $Q_n^m$  is measure-preserving and injective as a composition of measure-preserving and injective maps. Let  $\zeta_n^m$  be the partition defined by:

$$\zeta_n^m = \{\Gamma_{k,n}^m = Q_n^m \Gamma_{k,n}, k = 0, \dots, q_n - 1\}$$

Notice that for  $n \leq m - 1$ ,  $\zeta_n^m \hookrightarrow \zeta_{n+1}^m$ . Moreover,  $\zeta_n^m$  is stable by the translation  $T^{\frac{\gamma^{(n)}}{q_n}}$ . □

In order to obtain a full sequence of monotonic partitions stable by this translation, we need to take  $m \rightarrow +\infty$ .

Indeed, by adding conditions 6 (horizontal convergence) and 7 (vertical convergence), we obtain the lemma:

**Lemma 2.4.** *If assumptions 2, 3, 4, 6 and 7 of lemma 1.3 hold, then for any fixed  $n$ , the partition  $\zeta_n^m$  converges to a partition  $\zeta_n^\infty$  when  $m \rightarrow +\infty$ . Moreover, the sequence  $(\zeta_n^\infty)_{n \geq 0}$  is monotonous, generating and stable by  $T^{\frac{\gamma^{(n)}}{q_n}}$ .*

*Proof.* We show that  $\zeta_n^m$  is a Cauchy sequence for the metric on measurable partitions, a metric defined by:

$$d(\xi, \xi') = \inf \sum_{c \in \xi, c' \in \xi'} \mu(c \Delta c')$$

To show this fact, we need the lemma:

**Lemma 2.5.** *The numerical series  $\sum_{n \geq 0} \mu_h(\Gamma_{0,n} \Delta Q_n^{n+1} \Gamma_{0,n})$  is convergent.*

*Proof.* We first examine the horizontal difference between  $\Gamma_{0,n}$  and  $Q_n^{n+1} \Gamma_{0,n}$ . The element  $\Gamma^{(n,n+1)}$  is composed of all the  $\Gamma'_{i,n+1}$  that intersect  $\Gamma^{(n)}$ , except some, that still intersect the boundary of  $\Gamma^{(n)}$ . Therefore, the set  $\Gamma^{(n)} \setminus \Gamma^{(n,n+1)}$  is included in a neighborhood of width  $d_{n+1}$  of the boundary of  $\Gamma^{(n)}$  (figure 5).

Therefore,

$$\mu_{h-1}(\Gamma^{(n)} \setminus \Gamma^{(n,n+1)}) \leq \sigma_n d_{n+1}$$

Likewise, the elements  $\Gamma'_{i,n+1}$  of  $\Gamma^{(n,n+1)}$  that are not included in  $\Gamma^{(n)}$  always intersect the boundary of  $\Gamma^{(n)}$ . Therefore,

$$\mu_{h-1}(\Gamma^{(n,n+1)} \setminus \Gamma^{(n)}) \leq \sigma_n d_{n+1}$$

and therefore, by the condition 6 of horizontal convergence,

$$\sum_{n \geq 0} \gamma_h^{(n)} \mu_{h-1}(\Gamma^{(n,n+1)} \Delta \Gamma^{(n)}) < +\infty$$

Now, let

$$\hat{\Gamma}_{q_n}^{(n,n+1)} = \bigcup_{0 \leq t < \frac{1}{q_n}} T^t \gamma^{(n)} \Gamma^{(n,n+1)}$$

We have:

$$\mu_h(\Gamma_{0,n} \Delta \hat{\Gamma}_{q_n}^{(n,n+1)}) = \frac{1}{r_n} \mu_{h-1}(\Gamma^{(n)} \Delta \Gamma^{(n,n+1)})$$

Therefore,

$$\sum_{n \geq 0} q_n \mu_h(\Gamma_{0,n} \Delta \hat{\Gamma}_{q_n}^{(n,n+1)}) < +\infty$$

In order to obtain the lemma, it suffices to show that

$$\sum_{n \geq 0} q_n \mu_h(\Gamma_{q_n}^{(n,n+1)} \Delta \hat{\Gamma}_{q_n}^{(n,n+1)}) < +\infty$$

i.e. that we have vertical convergence.

Let  $0 \leq t \leq 1$ . We have:

$$\mu_{h-1} \left( T^t \frac{\gamma^{(n+1)}}{r_n \gamma_h^{(n+1)}} \Gamma^{(n,n+1)} \Delta T^t \frac{\gamma^{(n)}}{q_n} \Gamma^{(n,n+1)} \right) \leq 2\sigma_n \left| \frac{\gamma^{(n+1)}}{r_n \gamma_h^{(n+1)}} - \frac{\gamma^{(n)}}{q_n} \right|$$

Therefore,

$$\mu_h(\Gamma_{q_n}^{(n,n+1)} \Delta \hat{\Gamma}_{q_n}^{(n,n+1)}) \leq 2 \frac{\sigma_n}{r_n} \left| \frac{\gamma^{(n+1)}}{r_n \gamma_h^{(n+1)}} - \frac{\gamma^{(n)}}{q_n} \right|$$

Moreover,

$$\frac{\sigma_n}{r_n} \left| \frac{\gamma^{(n+1)}}{r_n \gamma_h^{(n+1)}} - \frac{\gamma^{(n)}}{q_n} \right| = \frac{\sigma_n (\gamma_h^{(n)})^2}{q_n^2} \left| \frac{\gamma^{(n+1)}}{\gamma_h^{(n+1)}} - \frac{\gamma^{(n)}}{\gamma_h^{(n)}} \right|$$

Since  $\sum_{n \geq 0} \frac{\sigma_n (\gamma_h^{(n)})^2}{q_n} \left| \frac{\gamma^{(n+1)}}{\gamma_h^{(n+1)}} - \frac{\gamma^{(n)}}{\gamma_h^{(n)}} \right| < +\infty$  by condition 7,<sup>2</sup> then also

$$\sum_{n \geq 0} q_n \mu_h(\Gamma_{q_n}^{(n,n+1)} \Delta \hat{\Gamma}_{q_n}^{(n,n+1)}) < +\infty$$

Hence lemma 2.5. □

<sup>2</sup>We do not find the same condition as in Anosov-Katok [1, p.29]: there is a mistake in their paper.

Now, we can prove the convergence of  $(\zeta_n^m)_{m>n}$ : for any fixed  $n$ ,  $n < m$ , we have:

$$\sum_{\Gamma_{k,n}^m \in \zeta_n^m} \mu_h(\Gamma_{k,n}^m \Delta Q_m^{m+1} \Gamma_{k,n}^m) = \sum_{k=0}^{q_n-1} \mu_h(Q_n^m \Gamma_{k,n} \Delta Q_m^{m+1} Q_n^m \Gamma_{k,n})$$

By volume conservation of the map  $Q_n^m$ ,  $Q_n^m \Gamma_{k,n}$  consists of  $\frac{q_m}{q_n}$  sets  $\Gamma_{l,m}$ , while  $Q_m^{m+1} Q_n^m \Gamma_{k,n}$  consists of the sets  $Q_m^{m+1} \Gamma_{l,m}^m$  with the same indices  $l$ .

Therefore, by lemma 2.5,

$$\sum_{m \geq 0} \sum_{\Gamma_{k,n}^m \in \zeta_n^m} \mu_h(\Gamma_{k,n}^m \Delta Q_m^{m+1} \Gamma_{k,n}^m) = \sum_{m \geq 0} \frac{q_m}{q_n} \mu_h(\Gamma_{0,m} \Delta Q_m^{m+1} \Gamma_{0,m}) < +\infty$$

This completes the proof of the convergence of  $\zeta_n^m$  towards a partition  $\zeta_n^\infty$ . Now, we show that  $\zeta_n^\infty$  is monotonous. Let  $n \geq 0$  and  $\epsilon > 0$ . Let  $m > n$  such that  $d(\zeta_n^m, \zeta_n^\infty) < \epsilon/2$  and  $d(\zeta_{n+1}^m, \zeta_{n+1}^\infty) < \epsilon/2$ . Let  $\Gamma_{k,n}^\infty \in \zeta_n^\infty$ , and  $\Gamma_{k,n}^m \in \zeta_n^m$  such that  $\mu_h(\Gamma_{k,n}^\infty \Delta \Gamma_{k,n}^m) \leq \epsilon/2$ .

Since  $\zeta_n^m \leftrightarrow \zeta_{n+1}^m$ , we can write:

$$\Gamma_{k,n}^m = \bigcup_{l \in L} \Gamma_{l,n+1}^m$$

Since  $d(\zeta_{n+1}^m, \zeta_{n+1}^\infty) < \epsilon/2$ , we have:

$$\mu_h\left(\bigcup_{l \in L} \Gamma_{l,n+1}^m \Delta \bigcup_{l \in L} \Gamma_{l,n+1}^\infty\right) \leq \sum_{l \in L} \mu_h(\Gamma_{l,n+1}^m \Delta \Gamma_{l,n+1}^\infty) \leq \epsilon/2$$

Therefore,

$$\mu_h\left(\Gamma_{k,n}^\infty \Delta \bigcup_{l \in L} \Gamma_{l,n+1}^\infty\right) \leq \mu_h(\Gamma_{k,n}^\infty \Delta \Gamma_{k,n}^m) + \mu_h\left(\Gamma_{k,n}^m \Delta \bigcup_{l \in L} \Gamma_{l,n+1}^m\right) + \mu_h\left(\bigcup_{l \in L} \Gamma_{l,n+1}^m \Delta \bigcup_{l \in L} \Gamma_{l,n+1}^\infty\right)$$

$$\mu_h\left(\Gamma_{k,n}^\infty \Delta \bigcup_{l \in L} \Gamma_{l,n+1}^\infty\right) \leq \epsilon/2 + 0 + \epsilon/2 = \epsilon$$

Since this estimate holds for any  $\epsilon > 0$ , we conclude that:

$$\mu_h\left(\Gamma_{k,n}^\infty \Delta \bigcup_{l \in L} \Gamma_{l,n+1}^\infty\right) = 0$$

Therefore,  $\zeta_n^\infty \leftrightarrow \zeta_{n+1}^\infty$ . The proof that  $T_{q_n}^{\frac{q_m}{q_n} \gamma^{(n)}}$  stabilizes  $\zeta_n^\infty$  is analogous.

Finally, let us show that  $(\zeta_n^\infty)_{n \geq 0}$  generates. Let  $G$  be a Lebesgue measurable set and let  $\epsilon > 0$ . Since  $\zeta_n$  generates, there exists  $n_0 \geq 0$  such that for any  $n \geq n_0$ , there is a  $\zeta_n$ -measurable set  $G_n$  such that  $\mu_h(G \Delta G_n) \leq \epsilon$ . Let  $I_n$  the (finite) set of indices such that

$$G_n = \bigcup_{i_n \in I_n} \Gamma_{i_n,n}$$

Let  $Q_n^\infty : \zeta_n \rightarrow \zeta_n^\infty$  be the limit isomorphism of the sequence  $Q_n^m$  (it exists by the first point of this lemma). Let

$$Q_n^\infty G_n = \bigcup_{i_n \in I_n} Q_n^\infty \Gamma_{i_n,n}$$

Since  $\zeta_n^m$  is a Cauchy sequence for the metric on partitions, we can fix an integer  $m_1 > n_0$  such that for any  $m \geq m_1$  and  $n \leq m$ :

$$\sum_{m' \geq m} \sum_{c \in \zeta_n^{m'}} \mu_h(Q_n^{m'+1} c \Delta Q_n^{m'} c) \leq \epsilon$$

Let  $n \geq m_1$ . Since for any  $c \in \zeta_n$ ,  $Q_n^n c = c$ , then

$$\begin{aligned} \mu_h(Q_n^\infty G_n \Delta G_n) &= \mu_h(Q_n^\infty G_n \Delta Q_n^n G_n) \leq \sum_{m \geq n} \mu_h(Q_n^{m+1} G_n \Delta Q_n^m G_n) \\ &= \sum_{m \geq n} \sum_{i_n \in I_n} \mu_h(Q_n^{m+1} \Gamma_{i_n, n} \Delta Q_n^m \Gamma_{i_n, n}) \leq \sum_{m \geq n} \sum_{c \in \zeta_n} \mu_h(Q_n^{m+1} c \Delta Q_n^m c) \leq \epsilon \end{aligned}$$

Hence the generation of  $\zeta_n^\infty$ .

□

Let us make one remark about the assumptions of lemma 1.3. If  $h = 2$ , there is a natural choice of sequence of fundamental domains  $\Gamma^{(n)}$  of the flow  $(T^{t\gamma^{(n)}})_{t \geq 0}$  such that  $\Gamma^{(n, n+1)} = \Gamma^{(n)}$ : we can choose  $\Gamma^{(n)} = [0, 1/(\gamma_2^{(n)})[$ . This choice allows to relax assumption 6, an assumption that is no longer useful for the convergence of  $\zeta_n^m$ . This relaxed assumption 6 remains useful to obtain the generation of the sequence of partitions  $(\zeta_n)_{n \geq 0}$ : this relaxed assumption is:  $d_n = 1/(\gamma_2^{(n)}) \rightarrow_{n \rightarrow +\infty} 0$ . However, this relaxation does not change the final statement of the theorem.

Moreover, if  $h = 2$ , assumption 4 is no longer used for the construction of  $\zeta_n^{n+1}$ . However, assumption 4 remains important for the construction of the metric isomorphism, see next section.

On the other hand, for  $h \geq 3$ , there is no natural choice of the sequence  $(\Gamma^{(n)})_{n \geq 0}$  that ensures that  $\Gamma^{(n, n+1)} = \Gamma^{(n)}$ . It is simpler to consider an arbitrary fundamental domain  $\Gamma^{(n)}$  of the flow  $(T^{t\gamma^{(n)}})_{t \geq 0}$ .

### 3 The metric isomorphism between the torus and the manifold $M = [0, 1]^{d-1} \times \mathbb{T}^1$ .

In this section, our aim is to elaborate sufficient conditions on  $B_n \in \text{Diff}^\infty(M, \mu)$  so that if  $T_n = B_n^{-1} S_{\frac{p_n}{q_n}} B_n$  weakly converges towards an automorphism  $T$ , then there exists a metric isomorphism between  $(\mathbb{T}^h, T^\alpha, \mu_h)$  and  $(M, T, \mu)$ , where  $M = [0, 1]^{d-1} \times \mathbb{T}^1$ .

To that end, we use lemma 1.2: with suitable assumptions, we construct a suitable sequence of partitions  $\xi_n^\infty$  of  $M$  and a sequence of isomorphisms  $\bar{K}_n^\infty : \mathbb{T}^h / \zeta_n^\infty \rightarrow M / \xi_n^\infty$  so that  $\bar{K}_n^\infty T_{\frac{p_n}{q_n}}^{\gamma^{(n)}} = T_n \bar{K}_n^\infty$ . In this construction, condition 4 is critical. Let

$$\eta_n = \{\Delta_{i, q_n} = [0, 1]^{d-1} \times \left[ \frac{i}{q_n}, \frac{i+1}{q_n} \right], i = 0, \dots, q_n - 1\}$$

Let

$$\begin{aligned} K_n : \zeta_n &\rightarrow \eta_n \\ \Gamma_{i, n} &\mapsto \Delta_{i, q_n} \end{aligned}$$

We recall from section 2 that there exists an isomorphism  $Q_n^{n+1} : \zeta_n \rightarrow \zeta_n^{n+1}$ , with  $\zeta_n^{n+1} \hookrightarrow \zeta_{n+1}$  and with  $Q_n^{n+1} T_{\frac{p_n}{q_n}}^{\gamma^{(n)}} = T_{\frac{p_n}{q_n}}^{\gamma^{(n)}} Q_n^{n+1}$ . We have the lemma:

**Lemma 3.1.** *There exists a partition  $\eta_n^{n+1} \hookrightarrow \eta_{n+1}$  of  $M$  stable by  $S_{\frac{1}{q_n}}$ , and there exists a metric isomorphism  $K_n^{n+1} : \zeta_n \rightarrow \eta_n^{n+1}$  such that  $K_n^{n+1} = K_{n+1}|_{\zeta_n}$  and such that  $K_n^{n+1} T^{\frac{\gamma(n)}{q_n}} = S_{\frac{1}{q_n}} K_n^{n+1}$ . There exists also a metric isomorphism  $C_n^{n+1} : \eta_n \rightarrow \eta_n^{n+1}$  such that  $C_n^{n+1} S_{\frac{a_n}{q_n}} = S_{\frac{a_n}{q_n}} C_n^{n+1}$  and  $K_n^{n+1} = C_n^{n+1} K_n$ . Said otherwise, we have the following commutative diagram:*

$$\begin{array}{ccc}
& \zeta_n & \xrightarrow{K_n} & \eta_n \\
& \downarrow Q_n^{n+1} & & \downarrow C_n^{n+1} \\
T^{\frac{\gamma(n)}{q_n}} \left( \zeta_n^{n+1} \right. & \xrightarrow{K_n^{n+1}} & \left. \eta_n^{n+1} \right) & S_{\frac{1}{q_n}} \\
& \downarrow & & \downarrow \\
& \zeta_{n+1} & \xrightarrow{K_{n+1}} & \eta_{n+1}
\end{array}$$

*Proof.* Let

$$\tilde{\Gamma}_{q_n}^{(n)} = \bigcup_{0 \leq i < \frac{1}{k_n q_n}} T^{i \gamma^{(n+1)}} \Gamma^{(n+1)}$$

and

$$\tilde{\zeta}_n = \{ \tilde{\Gamma}_{i,n} = T^{\frac{i}{k_n q_n} \gamma^{(n+1)}} \tilde{\Gamma}_{q_n}^{(n)}, 0 \leq i \leq q_n - 1 \}$$

Note that  $\zeta_n^{n+1} \hookrightarrow \tilde{\zeta}_n$ .

Let  $\tilde{\eta}_n = \{ \Delta_{i,k_n q_n}, i = 0, \dots, k_n q_n - 1 \}$  and  $\tilde{K}_n$  defined by:

$$\begin{aligned}
\tilde{K}_n : \tilde{\zeta}_n &\rightarrow \tilde{\eta}_n \\
\tilde{\Gamma}_{i,n} &\mapsto \Delta_{i,k_n q_n}
\end{aligned}$$

We have (figure 6):

$$\tilde{K}_n T^{\frac{\gamma(n)}{q_n}} = S_{\frac{1}{q_n}} \tilde{K}_n$$

Indeed, on the one hand,

$$S_{\frac{1}{q_n}} \tilde{K}_n \tilde{\Gamma}_{i,n} = S_{\frac{1}{q_n}} \Delta_{i,k_n q_n} = \Delta_{i+k_n, k_n q_n}$$

On the other hand, by condition 4 of lemma 1.3,  $T^{\frac{\gamma(n)}{q_n}} = T^{\frac{\gamma(n+1)}{q_n}}$ . Therefore,

$$\tilde{K}_n T^{\frac{\gamma(n)}{q_n}} \tilde{\Gamma}_{i,n} = \tilde{K}_n T^{\frac{\gamma(n+1)}{q_n}} \tilde{\Gamma}_{i,n} = \tilde{K}_n T^{\frac{k_n \gamma^{(n+1)}}{k_n q_n}} \tilde{\Gamma}_{i,n} = \tilde{K}_n T^{\frac{k_n + i \gamma^{(n+1)}}{k_n q_n}} \tilde{\Gamma}_{q_n}^{(n)} = \tilde{K}_n \tilde{\Gamma}_{i+k_n, n} = \Delta_{i+k_n, k_n q_n}$$

Now, let  $K_n^{n+1} = \tilde{K}_n|_{\zeta_n^{n+1}}$ . It implies:  $K_n^{n+1} = K_{n+1}|_{\zeta_n^{n+1}}$ .

Since  $T^{\frac{\gamma(n)}{q_n}}$  stabilizes  $\zeta_n^{n+1}$ , then we have:

$$K_n^{n+1} T^{\frac{\gamma(n)}{q_n}} = S_{\frac{1}{q_n}} K_n^{n+1}$$

Let us denote  $R^{(n)} = K_n^{n+1} \Gamma_{0,n}^{n+1}$ . There are integers  $a_n(i)$  such that:

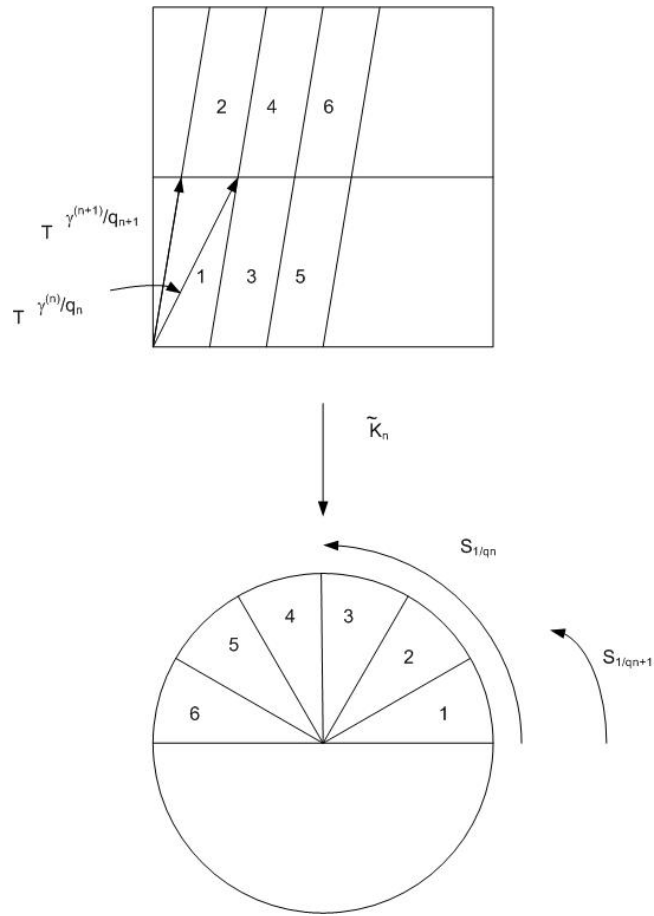

Figure 6: The isomorphism  $\tilde{K}_n$ . We took  $k_n = 3$ . The number  $i = 1, \dots, 6$  denotes  $\tilde{\Gamma}_{i,n}$  in the torus and  $\Delta_{i,k_n q_n}$  in the disk  $M$ . Moreover,  $R^{(n)} = \Delta_{1,k_n q_n} \cup \Delta_{3,k_n q_n} \cup \Delta_{5,k_n q_n}$

$$R^{(n)} = \bigcup_{i=0}^{k_n-1} \Delta_{a_n(i)k_n+i, k_n q_n}$$

Denote also  $R_{k,n}^{n+1} = S_{\frac{k}{q_n}} R^{(n)}$ ,  $k = 0, \dots, q_n - 1$ .  $R^{(n)}$  is a fundamental domain of  $S_{\frac{1}{q_n}}$  and we have:

$$K_n^{n+1} \Gamma_{k,n}^{n+1} = S_{\frac{k}{q_n}} R^{(n)} = R_{k,n}^{n+1}$$

Let

$$\eta_n^{n+1} = C_n^{n+1} \eta_n = \{R_{i,n}^{n+1}, i = 0, \dots, q_n - 1\}$$

Let us also denote  $C_n^{n+1}$  the map defined by:

$$\begin{aligned} C_n^{n+1} : \eta_n &\rightarrow \eta_n^{n+1} \\ \Delta_{i,q_n} &\mapsto R_{i,n}^{n+1} \end{aligned}$$

$C_n^{n+1}$  is bijective.  $\eta_n^{n+1} = C_n^{n+1} \eta_n$  is a partition of  $M$  stable by  $S_{\frac{1}{q_n}}$ , and since  $k_n q_n$  divides  $q_{n+1}$ , then  $\eta_n^{n+1} \hookrightarrow \eta_{n+1}$ .  $\square$

By iterating lemma 3.1, we get a corollary that is important for the construction of the isomorphism:

**Corollary 3.2.** *For any  $m > n$ , there are partitions  $\eta_n^m \hookrightarrow \eta_{n+1}^m$  of  $M$  such that  $\eta_n^m$  is stable by  $S_{\frac{1}{q_n}}$  and there exists an isomorphism  $K_n^m : \zeta_n^m \rightarrow \eta_n^m$  such that  $K_n^m T_{\frac{1}{q_n}}^{\gamma(n)} = S_{\frac{1}{q_n}} K_n^m$  and  $K_n^m = K_{n+1}^m|_{\eta_n^m}$ .*

*Said otherwise, we have the following commutative diagram:*

$$\begin{array}{ccc} T_{\frac{1}{q_n}}^{\gamma(n)} \curvearrowright \zeta_n^m & \xrightarrow{K_n^m} & \eta_n^m \curvearrowright S_{\frac{1}{q_n}} \\ \downarrow & & \downarrow \\ T_{\frac{1}{q_{n+1}}}^{\gamma(n+1)} \curvearrowright \zeta_{n+1}^m & \xrightarrow{K_{n+1}^m} & \eta_{n+1}^m \curvearrowright S_{\frac{1}{q_{n+1}}} \end{array}$$

*Proof.* The left hand side of the diagram comes from section 2. Since  $\eta_n^{n+1} \hookrightarrow \eta_{n+1}$ , we can define  $C_n^m = C_{m-1}^{n+1} \dots C_{n+1}^{n+1} C_n^{n+1}$ . Let  $\eta_n^m = C_n^m \eta_n$ . We have  $\eta_n^m \hookrightarrow \eta_{n+1}^m$ . Since  $C_n^m S_{\frac{1}{q_n}} = S_{\frac{1}{q_n}} C_n^m$ , then  $\eta_n^m$  is stable by  $S_{\frac{1}{q_n}}$ .

Moreover,  $Q_n^m : \zeta_n \rightarrow \zeta_n^m$  is bijective. Therefore, we can define

$$K_n^m = C_n^m K_n(Q_n^m)^{-1}. \text{ Since } Q_n^m T_{\frac{1}{q_n}}^{\gamma(n)} = T_{\frac{1}{q_n}}^{\gamma(n)} Q_n^m, \text{ and } C_n^m S_{\frac{1}{q_n}} = S_{\frac{1}{q_n}} C_n^m, \text{ we have:}$$

$$K_n^m T_{\frac{1}{q_n}}^{\gamma(n)} = S_{\frac{1}{q_n}} K_n^m.$$

Let us check that  $K_n^m = K_{n+1}^m|_{\eta_n^m}$ . Let  $c \in \zeta_n$ . Since  $C_n^{n+1}$  is bijective,  $(C_n^{n+1})^{-1}$  is well-defined, and we have:

$$K_{n+1}^m(Q_n^m c) = C_{n+1}^m K_{n+1}^m(Q_{n+1}^m)^{-1} Q_{n+1}^m c = C_n^m (C_n^{n+1})^{-1} K_{n+1}^m Q_n^{n+1} c$$

Since  $Q_n^{n+1} c \in \zeta_n^{n+1}$ , then  $K_{n+1}^m(Q_n^{n+1} c) = K_n^{n+1}(Q_n^{n+1} c)$ .

Since  $(C_n^{n+1})^{-1} K_{n+1}^m Q_n^{n+1} = K_n$ , we get:

$$K_{n+1}^m(Q_n^m c) = C_{n+1}^m K_{n+1}(Q_{n+1}^m)^{-1} Q_n^m c = C_n^m K_n c$$

On the other hand,

$$K_n^m(Q_n^m c) = C_n^m K_n(Q_n^m)^{-1} Q_n^m c = C_n^m K_n c$$

Therefore,  $K_n^m = K_{n+1}^m|_{\eta_n^m}$ .

□

The sequence  $\eta_n^m$  must converge when  $m \rightarrow +\infty$ , in order to obtain a full sequence of monotonic partitions. Moreover, the possible limit sequence (i.e. a possible  $\eta_n^\infty$ ) must generate. Indeed, these assumptions are required to apply lemma 1.2. However, we can check that none of these assumptions are satisfied. Therefore, to obtain these assumptions, we pull back the partition  $\eta_n^m$  by a suitable smooth measure-preserving diffeomorphism  $B_m$ . The following lemma gives the conditions that  $B_m$  must satisfy:

**Lemma 3.3.** *Let  $B_m \in \text{Diff}^\infty(M, \mu)$ . Let  $A_{m+1} = B_{m+1} B_m^{-1}$ .*

1. *If  $A_{m+1} S_{\frac{1}{q_m}}^\perp = S_{\frac{1}{q_m}}^\perp A_{m+1}$  and if*

$$\sum_{m \geq 0} q_m \mu(\Delta_{0, q_m} \Delta A_{m+1}^{-1} R^{(m)}) < +\infty$$

*then for any fixed  $n$ , when  $m \rightarrow +\infty$ , the sequence of partitions  $\xi_n^m = B_m^{-1} \eta_n^m$  converges. We denote  $\xi_n^\infty$  the limit. The sequence  $\xi_n^\infty$  is monotonous and  $T_n = B_n^{-1} S_{\frac{1}{q_n}}^\perp B_n$  stabilizes each  $\xi_n^\infty$ .*

2. *If, moreover, the sequence  $\xi_n = B_n^{-1} \eta_n$  generates, then so does  $\xi_n^\infty$ .*

*Proof.* The proof of the first point share similarities with the proof of lemma 2.5. Let  $P_n^m = B_m^{-1} C_n^m B_n$ . By the Cauchy criterion for sequences of partitions, in order to show the convergence of  $B_m^{-1} \eta_n^m$ , it suffices to show that for any fixed  $n$ ,

$$\sum_{m \geq 0} \sum_{c \in \xi_n^m} \mu(P_n^m c \Delta P_n^{m+1} c) < +\infty$$

We have:

$$\sum_{c \in \xi_n^m} \mu(P_n^m c \Delta P_n^{m+1} c) = \sum_{c \in B_m^{-1} \eta_n^m} \mu(B_m^{-1} C_n^m B_n c \Delta B_{m+1}^{-1} C_{m+1}^{m+1} C_n^m B_n c) = \sum_{c' \in \eta_n^m} \mu(B_m^{-1} c' \Delta B_{m+1}^{-1} C_{m+1}^{m+1} c')$$

Since  $B_m$  is measure-preserving,

$$\sum_{c' \in \eta_n^m} \mu(B_m^{-1} c' \Delta B_{m+1}^{-1} C_{m+1}^{m+1} c') = \sum_{c' \in \eta_n^m} \mu(c' \Delta B_m B_{m+1}^{-1} C_{m+1}^{m+1} c')$$

The partition  $\eta_n^m$  consists of  $q_m/q_n$  sets  $c'$  of the form  $\Delta_{u, q_m}$ , and  $C_{m+1}^{m+1} c'$  is a set  $R_{u, m}^{m+1}$  with the same indices  $u$ . Since  $A_{m+1} S_{\frac{1}{q_m}}^\perp = S_{\frac{1}{q_m}}^\perp A_{m+1}$ , we get:

$$\sum_{m \geq 0} \sum_{c' \in \eta_n^m} \mu(c' \Delta B_m B_{m+1}^{-1} C_{m+1}^{m+1} c') \leq \sum_{m \geq 0} \frac{q_m}{q_n} \mu(\Delta_{0, q_m} \Delta A_{m+1}^{-1} R_{0, m}^{m+1}) < +\infty$$



by assumption. Hence the convergence of  $\xi_n^m$ . We let  $P_n^\infty : \xi_n \rightarrow \xi_n^\infty$  be the limit isomorphism of the sequence  $P_n^m$ . The proof that the sequence  $\xi_n^\infty$  is monotonous is the same as the proof that  $\zeta_n^\infty$  is monotonous. See section 2.

To show that  $T_n$  stabilizes  $\xi_n^\infty$ , let  $T_n^m = B_m^{-1} S_{\frac{p_n}{q_n}} B_m$ . Since  $S_{\frac{p_n}{q_n}}$  stabilizes  $\eta_n^m$ , then  $T_n^m$  stabilizes  $\xi_n^m$ . Since  $A_{n+1} S_{\frac{1}{q_n}} = S_{\frac{1}{q_n}} A_{n+1}$ , then  $T_n^m = T_n$ . As in the proof that  $T_{\frac{p_n}{q_n}}^{\gamma^{(n)}}$  stabilizes  $\zeta_n^\infty$ , we obtain that  $T_n$  stabilizes  $\xi_n^\infty$ .

Likewise, the proof of the second point, i.e. that the sequence  $\xi_n^\infty$  generates, is the same as the proof that  $\zeta_n^\infty$  generates. See section 2.  $\square$

By adding to lemma 3.3 the convergence of the sequence  $T_n$ , we obtain the required isomorphism:

**Corollary 3.4.** *If both conditions 1. and 2. of lemma 3.3 hold, and if  $T_n = B_n^{-1} S_{\frac{p_n}{q_n}} B_n$  weakly converges towards an automorphism  $T$ , then  $(\mathbb{T}^h, T^\alpha)$  and  $(M, T)$  are metrically isomorphic.*

*Proof.* By corollary 3.2,  $K_n^m T_{\frac{p_n}{q_n}}^{\gamma^{(n)}} = S_{\frac{1}{q_n}} K_n^m$ . By iteration,  $K_n^m T_{\frac{p_n}{q_n}}^{\gamma^{(n)} p_n} = S_{\frac{p_n}{q_n}} K_n^m$ . Therefore, the following diagram commutes:

$$\begin{array}{ccccc}
& & S_{\frac{p_n}{q_n}} & & \\
& & \downarrow & & \\
T_{\frac{p_n}{q_n}}^{\gamma^{(n)}} \curvearrowright & \xi_n^m & \xrightarrow{K_n^m} & \eta_n^m & \xrightarrow{B_m^{-1}} & \xi_n^m \curvearrowright T_n \\
& \downarrow & & \downarrow & & \downarrow \\
T_{\frac{p_{n+1}}{q_{n+1}}}^{\gamma^{(n+1)}} \curvearrowright & \xi_{n+1}^m & \xrightarrow{K_{n+1}^m} & \eta_{n+1}^m & \xrightarrow{B_{n+1}^{-1}} & \xi_{n+1}^m \curvearrowright T_{n+1} \\
& & & \downarrow & & \\
& & & S_{\frac{p_{n+1}}{q_{n+1}}} & & 
\end{array}$$

We apply lemma 3.3, which gives a sequence of monotonous and generating partitions  $\xi_n^\infty$ , stable by  $T_n$ . Let  $\bar{K}_n^\infty : \zeta_n^\infty \rightarrow \xi_n^\infty$  defined by  $\bar{K}_n^\infty = P_n^\infty B_n^{-1} K_n (Q_n^\infty)^{-1}$ . We can show that  $\bar{K}_n^\infty T_{\frac{p_n}{q_n}}^{\gamma^{(n)}} = T_n \bar{K}_n^\infty$  and that  $\bar{K}_{n+1}^\infty|_{\zeta_n^\infty} = \bar{K}_n^\infty$  by using that  $\bar{K}_n^m T_{\frac{p_n}{q_n}}^{\gamma^{(n)}} = T_n \bar{K}_n^m$  and that  $\bar{K}_{n+1}^m|_{\zeta_n^m} = \bar{K}_n^m$ , where  $\bar{K}_n^m = P_n^m B_n^{-1} K_n (Q_n^m)^{-1}$ , i.e. we proceed as in the proof of the monotonicity of  $\zeta_n^\infty$ , in lemma 2.4 of section 2. This allows to apply lemma 1.2, which gives the required metric isomorphism.  $\square$

The next section is dedicated to the construction of the sequence of diffeomorphisms  $B_n$  satisfying the conditions of lemma 3.3.

## 4 The sequence of conjugacies

In this section, we construct a sequence of diffeomorphisms  $B_n$  on  $M$  satisfying the conditions of lemma 3.3 and such that  $\|B_n\|_n \leq (q_{n-1} k_{n-1})^{R_4(n-1)}$  for some  $R_4(n)$ .

**Proposition 4.1.** *There exists a sequence of diffeomorphisms  $B_n \in \text{Diff}^\infty(M, \mu)$  such that  $B_n$  and  $A_{n+1} = B_{n+1} B_n^{-1}$  satisfy the following conditions:*

1. (convergence of the partition  $\xi_n^m$  to  $\xi_n^\infty$ )

$$\sum_{m \geq 0} q_m \mu \left( \Delta_{0, q_m} \Delta A_{m+1}^{-1} R^{(m)} \right) < +\infty$$

2. (generation) There is a set  $E_{n+1} \subset M$  such that  $\sum_{n \geq 0} \mu(E_{n+1}^c) < +\infty$  and such that

$$\text{diam} \left( A_{n+1}^{-1} \left( \Delta_{0, q_{n+1}} \cap E_{n+1} \right) \right) \leq \frac{1}{2^n \|B_n\|_1}$$

3. (equivariance)

$$A_{n+1} S_{\frac{1}{q_n}} = S_{\frac{1}{q_n}} A_{n+1}$$

4. (polynomial estimation) There is a fixed sequence  $R_4(n) \in \mathbb{N}$  such that

$$\|A_{n+1}\|_{n+1} \leq (q_n k_n)^{R_4(n)}$$

**Remark 4.2.** Specification 2 above implies that  $\xi_n$  generates (and so  $\xi_n^\infty$ , by lemma 3.3), see proposition 4.9.

We construct  $B_n$  recursively. We suppose that  $B_n$  exists and satisfies these specifications, and we construct  $A_{n+1}$ .

The diffeomorphism  $A_{n+1}$  is constructed in two steps when  $d = 2$  (three steps when  $d \geq 3$ ), each step gives a smooth, measure-preserving, equivariant and polynomially controlled map. In the first step, lemma 4.3, we construct a smooth map  $A_{n+1}^1$  that "quasi-cuts"  $\Delta_{0, q_n}$  in  $k_n$  equal vertical slices, and then rotates each slice  $\Gamma_i$  by an angle  $a_n(i)/q_n$  along the periodic flow  $S_t$  (remember that the parameters  $0 \leq a_n(i) \leq q_n - 1$  are defined by  $R^{(n)} = \bigcup_{i=0}^{k_n-1} \Delta_{a_n(i)k_n+i, k_n q_n}$ ) (see figure 7).

In the second step, we construct a second map  $A_{n+1}^2$  that "quasi-sends" each vertical slice  $A_{n+1}^1(\Gamma_i)$  into the horizontal slice  $\Delta_{a_n(i)k_n+i, k_n q_n}$  (see figures 8 and 9). These two steps ensure that  $A_{n+1} = A_{n+1}^2 A_{n+1}^1$  "quasi-sends"  $\Delta_{0, q_n}$  to  $R^{(n)}$ . It ensures that  $\xi_n$  converges. Moreover, when  $d = 2$ , this also gives the generation of  $\xi_n$  (and so of  $\xi_n^\infty$ ).

For  $d \geq 3$  we need a third step. Inside each  $\Delta_{i, k_n q_n}$ , we quasi-rotate the slices  $\Delta_{j, (k_n q_n)^d}$  with  $A_{n+1}^3$ , so that the diameter of  $A_{n+1}^{-1}(\Delta_{i, q_{n+1}})$  is small, where  $A_{n+1} = A_{n+1}^3 A_{n+1}^2 A_{n+1}^1$  (see figures 10, 11, 12, 13). This guarantees that  $\xi_n$  generates (and so  $\xi_n^\infty$ ), which completes the construction.

First, we write the construction in the case  $M = [0, 1] \times \mathbb{T}$ , and then we extend it to  $M = [0, 1]^{d-1} \times \mathbb{T}$ .

## 4.1 Construction in dimension 2

The first step is based on the lemma (see figure 7):

**Lemma 4.3.** Let  $\frac{1}{k_n} > \epsilon_1 > 0$  and for  $0 \leq i \leq k_n - 1$ , let  $\Gamma_i = [\frac{i}{k_n}, \frac{i+1}{k_n} - \epsilon_1] \times [0, \frac{1}{q_n}]$ . There is a smooth measure-preserving diffeomorphism  $A_{n+1}^1 : [0, 1] \times \mathbb{T} \rightarrow [0, 1] \times \mathbb{T}$  such that:

1.

$$A_{n+1}^1 S_{\frac{1}{q_n}} = S_{\frac{1}{q_n}} A_{n+1}^1$$

2.

$$A_{n+1}^1(\Gamma_i) = S_{\frac{a_n(i)}{q_n}} \Gamma_i$$

3.

$$\|A_{n+1}^1\|_l \leq \frac{1}{\epsilon_1} \|\phi\|_l$$

where  $\phi$  is a fixed smooth diffeomorphism independent of  $n$  and  $\epsilon_1$ .

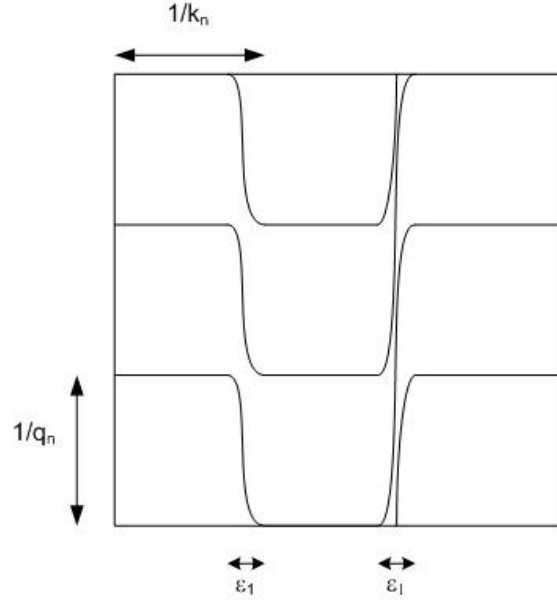

Figure 7: The image of the partition  $\eta_n$  after step 1.

*Proof.* Let  $\phi : \mathbb{R} \rightarrow \mathbb{R}$  be a smooth increasing function that equals 0 for  $x \leq -1$  and 1 for  $x \geq 0$ . Let  $\phi^{n,\epsilon_1} : [0, 1] \rightarrow [0, 1]$  defined by:

$$\phi^{n,\epsilon_1}(x) = \frac{a_n(0)}{q_n} + \frac{a_n(1) - a_n(0)}{q_n} \phi\left(\frac{x}{\epsilon_1} - \frac{1}{k_n \epsilon_1}\right) + \dots + \frac{a_n(k_n - 1) - a_n(k_n - 2)}{q_n} \phi\left(\frac{x}{\epsilon_1} - \frac{k_n - 1}{k_n \epsilon_1}\right)$$

For  $0 \leq i \leq k_n - 1$ , we have:  $\phi_{\left[\frac{i}{k_n}, \frac{i+1}{k_n} - \epsilon_1\right]}^{n,\epsilon_1} = \frac{a_n(i)}{q_n}$ , with the estimation:

$$\|\phi^{n,\epsilon_1}\|_l \leq \frac{1}{\epsilon_1} \|\phi\|_l$$

Finally, for  $x \in M$ , let  $A_{n+1}^1(x) = S_{\phi^{n,\epsilon_1}(x)}(x)$ . It satisfies all the specifications of the lemma. □

We take  $\epsilon_1 = \frac{1}{k_n 2^n}$  and we let

$$E_{n+1}^1 = \bigcup_{i=0}^{k_n-1} \left[ \frac{i}{k_n}, \frac{i+1}{k_n} - \epsilon_1 \right] \times \mathbb{T}$$

We have:

$$\mu(E_{n+1}^{1c}) = k_n \epsilon_1 = \frac{1}{2^n}$$

In the second step, we shrink  $\Gamma_i$  horizontally by a factor  $q_n$ , we expand it vertically by the same factor, and we rotate it by a  $\pi/2$  angle (except in a neighborhood of the border of  $\Delta_{0,q_n}$ ). Thus,  $\Gamma_i$  is quasi-sent to  $\Delta_{i,k_n q_n}$ . Note that with this operation, we automatically obtain the right combinatorics of  $R^{(n)}$ .

This step is slightly different than in Anosov-Katok's original paper, but this difference is critical: following Anosov-Katok's original method, we would need to quasi-permute  $k_n q_n$  slices, in order to match the location of  $R^{(n)}$ . This would require at least  $q_n$  iterations, thus jeopardizing the polynomial estimation in  $q_n$ , and ultimately the obtention of all Liouville numbers on the  $h^{\text{th}}$  coordinate.

We have the lemma (see figures 8 and 9):

**Lemma 4.4.** *Let  $\Gamma'_i = [\frac{i}{k_n}, \frac{i+1}{k_n}] \times [0, \frac{1}{q_n}]$ . There exists a map  $A_{n+1}^2$  equivariant by  $S_{\frac{1}{q_n}}$  and there exists a measurable set  $E_{n+1}^2$  such that  $\mu(E_{n+1}^2) \geq 1 - 4/2^n$ , such that  $E_{n+1}^2$  is globally invariant by  $S_{\frac{1}{q_n}}$  and  $A_{n+1}^2$ , and such that*

$$A_{n+1}^2 \left( \Gamma'_i \cap E_{n+1}^2 \right) = \Delta_{i,k_n q_n} \cap E_{n+1}^2$$

In particular,

$$\text{diam} \left( (A_{n+1}^2)^{-1} \Delta_{i,k_n q_n} \cap E_{n+1}^2 \right) \leq \max \left( \frac{1}{q_n}, \frac{1}{k_n} \right)$$

Moreover, there is an explicit function  $R_2(j)$ , depending only on  $j$ , such that

$$\|A_{n+1}^2\|_j \leq (q_n)^{R_2(j)} \|\phi_n\|_j$$

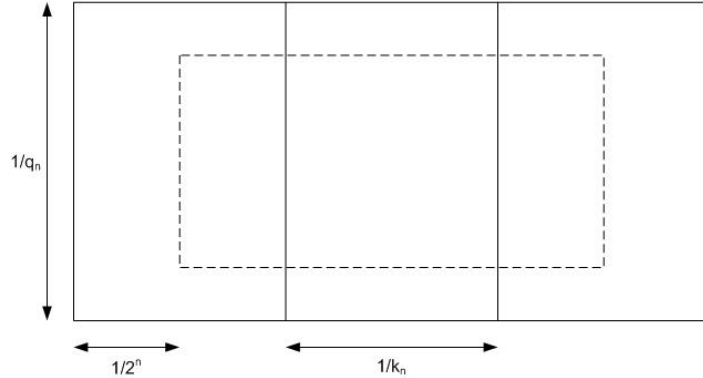

Figure 8: The partition  $A_{n+1}^1 \eta_n \cap [0, 1] \times [\frac{i}{q_n}, \frac{i+1}{q_n}]$  before step 2 ( $\epsilon_1$  has been taken infinitesimally small in the illustration).

Combined with lemma 4.3, this lemma gives the convergence of the partition  $\xi_n$  to  $\xi_n^{\infty}$ :

**Corollary 4.5.** *We have the estimation:*

$$\mu \left( A_{n+1}^2 A_{n+1}^1 \left( \Delta_{0,q_n} \right) \Delta R^{(n)} \right) \leq \frac{8}{2^n q_n}$$

*Proof of lemma 4.4.* We need to recall the definition of a "quasi-rotation" by  $\pi/2$  [3]:

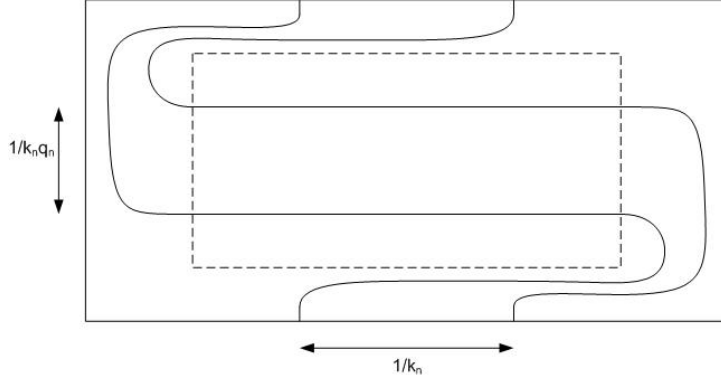

Figure 9: The partition  $A_{n+1}^1 \eta_n \cap [0, 1] \times \left[ \frac{i}{q_n}, \frac{i+1}{q_n} \right]$  after step 2 ( $\epsilon_1$  has been taken infinitesimally small in the illustration).

**Proposition 4.6.** *For any  $n \geq 1$ , there is a smooth measure preserving map  $\phi_n : [0, 1]^2 \Rightarrow [0, 1]^2$  (called "quasi-rotation") such that  $\phi_n = R_{\pi/2}$  on  $[\frac{1}{2^n}, 1 - \frac{1}{2^n}]^2$  and  $\phi_n = Id$  on a neighborhood of the boundary of  $[0, 1]^2$ .*

Let  $p \geq 2$  and

$$\begin{aligned} C_p : [0, 1] \times [0, \frac{1}{p}] &\rightarrow [0, 1] \times [0, 1] \\ (x, y) &\mapsto (x, py) \end{aligned}$$

Let  $\phi_{n,p} = C_p^{-1} \phi_n C_p$ . The map  $\phi_{n,p}$  is measure preserving. By the Faa-di-Bruno formula, there exists a fixed function  $R_5(j)$  such that

$$\|\phi_{n,p}\|_j \leq p^{R_5(j)} \|\phi_n\|_j$$

Let  $A_{n+1}^2 = \phi_{n,q_n}$  on  $[0, 1] \times [0, \frac{1}{q_n}]$ , extended to  $[0, 1] \times \mathbb{T}$  by  $1/q_n$  periodicity. We have:

$$\|A_{n+1}^2\|_j \leq q_n^{R_5(j)} \|\phi_n\|_j$$

For  $r = 0, \dots, q_n - 1$ , let

$$E_{n+1,r}^2 = \left[ \frac{1}{2^n}, 1 - \frac{1}{2^n} \right] \times \left[ \frac{r}{q_n} + \frac{1}{q_n 2^n}, \frac{r+1}{q_n} - \frac{1}{q_n 2^n} \right]$$

and

$$E_{n+1}^2 = \bigcup_{r=0}^{q_n-1} E_{n+1,r}^2$$

The set  $E_{n+1}^2$  is invariant by  $S_{\frac{1}{q_n}}$  and  $A_{n+1}^2$ . Moreover,

$$A_{n+1}^2 \left( \Gamma'_i \bigcap E_{n+1}^2 \right) = A_{n+1}^2 \left( \Gamma'_i \bigcap E_{n+1,0}^2 \right) = \Delta_{i,k_n q_n} \bigcap E_{n+1}^2$$

□

*Proof of corollary 4.5.* By lemma 4.4 (using in particular that  $E_{n+1}^2$  is  $S_{\frac{1}{q_n}}$ -invariant, and that  $A_{n+1}^2$  is  $S_{\frac{1}{q_n}}$ -equivariant),

$$\begin{aligned} A_{n+1}^2 \left( \bigcup_{i=0}^{k_n-1} S_{\frac{a_n(i)}{q_n}} \Gamma'_i \cap E_{n+1}^2 \right) &= \bigcup_{i=0}^{k_n-1} A_{n+1}^2 \left( S_{\frac{a_n(i)}{q_n}} \Gamma'_i \cap E_{n+1}^2 \right) \\ &= \bigcup_{i=0}^{k_n-1} S_{\frac{a_n(i)}{q_n}} \Delta_{i,k_n q_n} \cap E_{n+1}^2 = R^{(n)} \cap E_{n+1}^2 \end{aligned}$$

On the other hand, by lemma 4.3,

$$A_{n+1}^1 \left( \Delta_{0,q_n} \cap E_{n+1}^1 \right) = \bigcup_{i=0}^{k_n-1} S_{\frac{a_n(i)}{q_n}} \Gamma'_i \cap E_{n+1}^1$$

Therefore, if we let  $A'_{n+1} = A_{n+1}^2 A_{n+1}^1$ , we obtain:

$$A'_{n+1} \left( \Delta_{0,q_n} \cap E_{n+1}^1 \cap (A_{n+1}^1)^{-1} (E_{n+1}^2) \right) = R^{(n)} \cap A_{n+1}^2 (E_{n+1}^1) \cap E_{n+1}^2$$

Thus,

$$\begin{aligned} \mu \left( A'_{n+1} \Delta_{0,q_n} \Delta R^{(n)} \right) &\leq \mu \left( A'_{n+1} \Delta_{0,q_n} \Delta A'_{n+1} \left( \Delta_{0,q_n} \cap E_{n+1}^1 \cap (A_{n+1}^1)^{-1} (E_{n+1}^2) \right) \right) + \\ &\quad \mu \left( A'_{n+1} \left( \Delta_{0,q_n} \cap E_{n+1}^1 \cap (A_{n+1}^1)^{-1} (E_{n+1}^2 \Delta R^{(n)}) \right) \right) \end{aligned}$$

But on the one hand, since  $A'_{n+1}$  is measure preserving,

$$\begin{aligned} \mu \left( A'_{n+1} \Delta_{0,q_n} \Delta A'_{n+1} \left( \Delta_{0,q_n} \cap E_{n+1}^1 \cap (A_{n+1}^1)^{-1} (E_{n+1}^2) \right) \right) &= \\ \mu \left( \Delta_{0,q_n} \Delta \left( \Delta_{0,q_n} \cap E_{n+1}^1 \cap (A_{n+1}^1)^{-1} (E_{n+1}^2) \right) \right) &= \mu \left( \Delta_{0,q_n} \cap \left( E_{n+1}^{1c} \cup (A_{n+1}^1)^{-1} (E_{n+1}^{2c}) \right) \right) \\ &\leq \mu \left( E_{n+1,0}^{1c} \right) + \mu \left( E_{n+1,0}^{2c} \right) \leq \frac{2}{2^n q_n} + \frac{2}{2^n q_n} = \frac{4}{2^n q_n} \end{aligned}$$

And likewise, by using  $S_{\frac{1}{q_n}}$ -invariance, since  $R^{(n)} = \bigcup_{i=0}^{k_n-1} S_{\frac{a_n(i)}{q_n}} \Delta_{i,k_n q_n}$ ,

$$\mu \left( R^{(n)} \cap A_{n+1}^2 (E_{n+1}^1) \cap E_{n+1}^2 \right) = \mu \left( \Delta_{0,q_n} \cap A_{n+1}^2 (E_{n+1}^1) \cap E_{n+1}^2 \right) \leq \frac{4}{2^n q_n}$$

□

Moreover, we automatically obtain generation of  $\xi_n$  (and so  $\xi_n^{\infty}$ ). Indeed, by applying the induction assumption,  $\|B_n\|_1 \leq (k_{n-1} q_{n-1})^{R_6(n-1)}$  for some  $R_6(n)$ . If, in assumption 2 of lemma 1.3, we choose  $R_2(n)$  such that  $q_n \geq 2^n (\gamma_h^{(n)} q_{n-1})^{R_2(n-1)}$  (remember that we took  $k_n = \gamma_h^{(n)}$ ), and since  $\gamma_h^{(n+1)} \geq q_n$ , then lemma 4.4 gives:

$$\text{diam} \left( (A_{n+1}^2)^{-1} \Delta_{l,k_n q_n} \cap E_{n+1}^2 \right) \leq \frac{1}{2^n \|B_n\|_1}$$

We obtain the conditions of proposition 4.9, which imply generation:

**Proposition 4.7.** *Let  $A_{n+1} = A_{n+1}^2 A_{n+1}^1$  and  $E_{n+1} = E_{n+1}^2 \cap A_{n+1}^2(E_{n+1}^1)$ . We have  $\mu(E_{n+1}) \geq 1 - 8/2^n$ , and there exists an explicit sequence of integers  $R_2(n)$  depending only on  $n$ , such that, for any  $q_{n+1} = q'_{n+1}(\gamma_h^{(n+1)} q_n)^{R_2(n)}$ ,  $0 \leq l \leq q_{n+1} - 1$ , we have:*

$$\text{diam}\left((A_{n+1})^{-1}\left(\Delta_{l,q_{n+1}} \cap E_{n+1}\right)\right) \leq \frac{1}{2^n \|B_n\|_1}$$

## 4.2 Construction in higher dimensions

First, we consider the case  $M = [0, 1]^{d-1} \times \mathbb{T}$ . The first step is the same as in dimension 2: We let  $\Gamma_i = [\frac{i}{k_n}, \frac{i+1}{k_n} - \epsilon_1] \times [0, 1]^{d-2} \times [0, \frac{1}{q_n}]$  and for  $x = (x_1, \dots, x_d) \in M$ , we consider the map  $A_{n+1}^1(x) = S_{\phi_{n,\epsilon_1}(x_1)}(x) = (x_1, \dots, x_{d-1}, x_d + \phi_{n,\epsilon_1}(x_1))$ .

The second step is also the same as in dimension 2: we quasi-rotate in the  $(x_1, x_d)$  plan (the plan in which we sliced the  $\Gamma_i$ ). We write  $\phi_{n,q_n}(x, y) = (\phi_{n,q_n,1}(x, y), \phi_{n,q_n,2}(x, y))$ . We let  $A_{n+1}^2(x_1, \dots, x_d) = (\phi_{n,q_n,1}(x_1, x_d), x_2, \dots, x_{d-1}, \phi_{n,q_n,2}(x_1, x_d))$  on  $[0, 1] \times [0, \frac{1}{q_n}]$ , and we extend it to  $[0, 1] \times \mathbb{T}$  by  $1/q_n$  periodicity along the  $x_d$  coordinate.

The third step is different: to obtain generation, we have to combine all dimensions. We proceed as in [3, pp.1808-1809]. We have the proposition:

**Proposition 4.8.** *There exists a smooth measure-preserving and  $S_{\frac{1}{k_n q_n}}$ -equivariant diffeomorphism  $A_{n+1}^3$ , and there is an explicit function  $R_7(j)$ , depending only on  $j$  and  $d$ , such that*

$$\|A_{n+1}^3\|_j \leq (k_n q_n)^{R_7(j)} \|\phi_n\|_j$$

and there is a set  $E_{n+1}$  satisfying the assumptions of proposition 4.9 such that if  $A_{n+1} = A_{n+1}^3 A_{n+1}^2 A_{n+1}^1$ , then for any choice of  $q_{n+1} = q'_{n+1} (k_n q_n)^{R_2(n)}$ , with  $R_2(n)$  multiple of  $d$ , we have:

$$\text{diam}\left((A_{n+1})^{-1}\left(\Delta_{l,q_{n+1}} \cap E_{n+1}\right)\right) \leq \frac{1}{2^n \|B_n\|_1}$$

*Proof.* For  $i = 0, \dots, d-1$ , let  $\phi_{n,k_n q_n}^i(x_1, \dots, x_d) = (x_1, \dots, x_{i-1}, \phi_{n,k_n q_n}(x_i, x_{i+1}), x_{i+2}, \dots, x_d)$ , extended by  $1/k_n q_n$ -periodicity along the  $x_d$  coordinate. We let (see figures 10, 11, 12, 13):

$$A_{n+1}^3(x_1, \dots, x_d) = \phi_{n,k_n q_n}^{d-1} \dots \phi_{n,k_n q_n}^1(x_1, \dots, x_d)$$

Let also  $A_{n+1} = A_{n+1}^3 A_{n+1}^2 A_{n+1}^1$ . For  $j = 1, \dots, d-1$ ,  $r = 0, \dots, k_n q_n - 1$ , let also

$$E_{j,r} = [0, 1]^{j-1} \times \left[ \frac{1}{2^n}, 1 - \frac{1}{2^n} \right] \times \left[ \frac{r}{k_n q_n} + \frac{1}{k_n q_n 2^n}, \frac{r+1}{k_n q_n} - \frac{1}{k_n q_n 2^n} \right] \times [0, 1]^{d-(j+1)}$$

(in the notations, we omit dependencies in  $n$ ) and

$$E_j = \bigcup_{r=0}^{k_n q_n - 1} E_{j,r}$$

Note that  $E_j$  is  $\phi_{n,k_n q_n}^j$ -invariant. We let

$$E_{n+1}^3 = E - \phi_{n,k_n q_n}^1(E_2) \cap \dots \cap \phi_{n,k_n q_n}^1 \dots \phi_{n,k_n q_n}^{d-2}(E_{d-1})$$

and

$$E_{n+1} = E_{n+1}^3 \cap A_{n+1}^3(E_{n+1}^2) \cap A_{n+1}^3 A_{n+1}^2(E_{n+1}^1)$$

We obtain, for  $l = 0, \dots, (k_n q_n)^d - 1$ :

$$\text{diam}\left((A_{n+1}^3)^{-1} \Delta_{l, (k_n q_n)^d} \cap E_{n+1}^3\right) \leq \frac{1}{k_n q_n}$$

Therefore, by lemma 4.4,

$$\text{diam}\left((A_{n+1}^2)^{-1} \left((A_{n+1}^3)^{-1} \left(\Delta_{l, (k_n q_n)^d} \cap E_{n+1}^3\right)\right) \cap E_{n+1}^2\right) \leq \frac{1}{k_n}$$

and therefore, we also have:

$$\text{diam}\left((A_{n+1}^1)^{-1} \left((A_{n+1}^2)^{-1} \left((A_{n+1}^3)^{-1} \left(\Delta_{l, (k_n q_n)^d} \cap E_{n+1}^3\right)\right) \cap E_{n+1}^2\right) \cap E_{n+1}^1\right) \leq \frac{1}{k_n} \leq \frac{1}{2^n \|B_n\|_1}$$

Finally, for any choice of  $q_{n+1} = q'_{n+1} (k_n q_n)^{R_2(n)}$ , with  $R_2(n)$  multiple of  $d$ , we obtain the wanted estimation:

$$\text{diam}\left((A_{n+1})^{-1} \left(\Delta_{l, q_{n+1}} \cap E_{n+1}\right)\right) \leq \frac{1}{2^n \|B_n\|_1}$$

Thus, we get generation. □

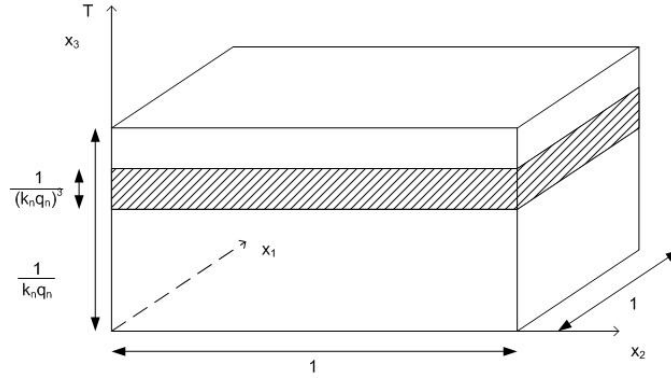

Figure 10: An element  $\Delta_{l, (k_n q_n)^d}$  for  $d = 3$ , before the application of  $(A_{n+1}^3)^{-1} = (\phi_{n, k_n q_n}^1)^{-1} (\phi_{n, k_n q_n}^2)^{-1}$ . Its size is  $1 \times 1 \times 1 / (k_n q_n)^3$ .



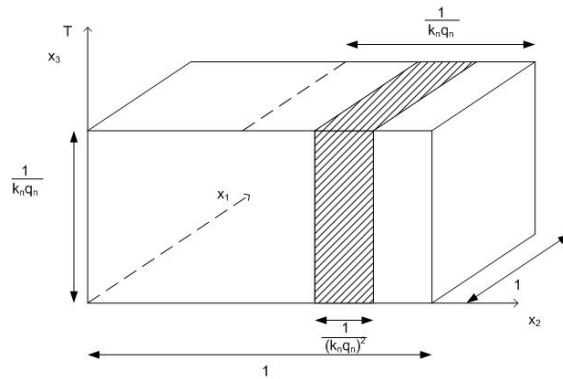

Figure 11: The element  $(\phi_{n,k_n q_n}^2)^{-1} (\Delta_{l,(k_n q_n)^d}) \cap E_{n+1}^3$ . Its size is less than  $1 \times 1 / (k_n q_n)^2 \times 1 / (k_n q_n)$ .

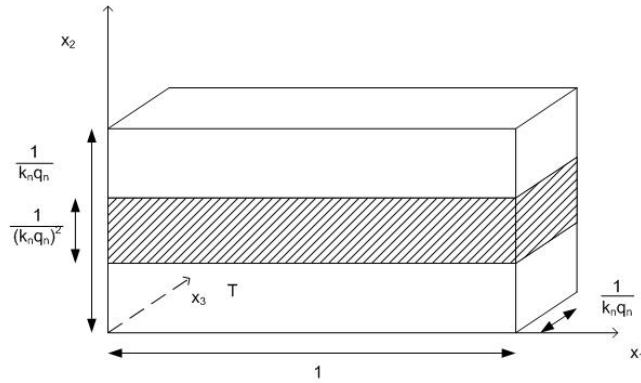

Figure 12: The element  $(\phi_{n,k_n q_n}^2)^{-1} (\Delta_{l,(k_n q_n)^d}) \cap E_{n+1}^3$ , in the plan  $(x_1, x_2)$ .

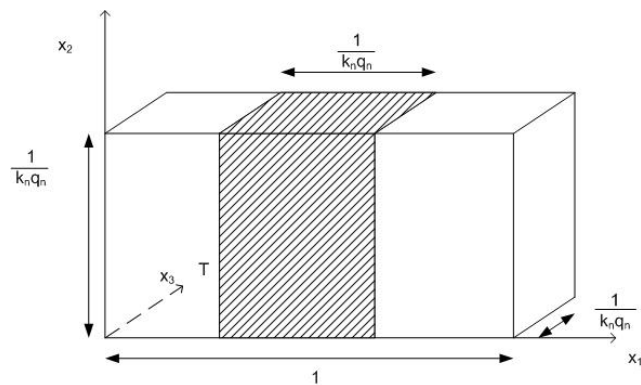

Figure 13: The element  $(\phi_{n,k_n q_n}^1)^{-1} (\phi_{n,k_n q_n}^2)^{-1} (\Delta_{l,(k_n q_n)^d}) \cap E_{n+1}^3$ , in the plan  $(x_1, x_2)$ . Its size is less than  $1 / (k_n q_n) \times 1 / (k_n q_n) \times 1 / (k_n q_n)$ .

### 4.3 Generation of $\xi_n$ , convergence of the sequence of diffeomorphisms and ergodicity of the limit

By combining lemma 3.3, corollary 3.4, and proposition 4.1, in order to complete the proof of lemma 1.3, it remains to show that  $\xi_n$  generates, that  $T_n = B_n^{-1} S_{\frac{p_n}{q_n}} B_n$  converges in the smooth topology, and that the limit  $T$  of  $T_n$  is ergodic.

#### 4.3.1 Generation of $\xi_n$

**Proposition 4.9.** *If there is a set  $E_{n+1} \subset M$  such that  $\sum_{n \geq 0} \mu(E_{n+1}^c) < +\infty$  and such that for any  $0 \leq l \leq q_{n+1} - 1$ ,*

$$\text{diam}\left(A_{n+1}^{-1}\left(\Delta_{l,q_{n+1}} \cap E_{n+1}\right)\right) \leq \frac{1}{2^n \|B_n\|_1}$$

then  $\xi_n$  generates.

*Proof.* By the Borel-Cantelli lemma,

$$\mu(\liminf E_n) = 1$$

Let  $E = \liminf E_n$  and let  $x \in E$ . By extracting, we can suppose that  $x \in E_n$  for any  $n$ . Let  $c_n(x) \in \xi_n$  such that  $x \in c_n(x)$ . We have:  $\{x\} \subset \bigcap_{n \geq 0} E_n \cap c_n(x)$ . Moreover, since

$$\text{diam}\left(A_{n+1}^{-1}\left(\Delta_{l,q_{n+1}} \cap E_{n+1}\right)\right) \leq \frac{1}{2^n \|B_n\|_1}$$

then

$$\text{diam}\left(B_{n+1}^{-1}\left(\Delta_{l,q_{n+1}} \cap E_{n+1}\right)\right) \leq \frac{1}{2^n}$$

(note that this intersection may be empty for some  $l$ ), and therefore,

$\text{diam}(E_n \cap c_n(x)) \rightarrow_{n \rightarrow +\infty} 0$ . So  $\bigcap_{n \geq 0} E_n \cap c_n(x)$  is at most a singleton, and  $\xi_n$  generates. □

#### 4.3.2 Convergence

To complete the proof of lemma 1.3 for  $M = [0, 1]^{d-1} \times \mathbb{T}$ , we need to show the convergence of  $T_n = B_n^{-1} S_{\frac{p_n}{q_n}} B_n$ . By the Cauchy criterion, it suffices to show that  $\sum_{n \geq 0} d_n(T_{n+1}, T_n)$  converges. We combine the estimation of  $B_{n+1}$  and the assumption of closeness between  $p_{n+1}/q_{n+1}$  and  $p_n/q_n$  of lemma 1.3. We recall the lemma [3, p.1812]:

**Lemma 4.10.** *Let  $k \in \mathbb{N}$ . There is a constant  $C(k, d)$  such that, for any  $h \in \text{Diff}(M)$ ,  $\alpha_1, \alpha_2 \in \mathbb{R}$ , we have:*

$$d_k(hS_{\alpha_1} h^{-1}, hS_{\alpha_2} h^{-1}) \leq C(k, d) \|h\|_{k+1}^{k+1} |\alpha_1 - \alpha_2|$$

Since  $T_n = B_n^{-1} S_{\frac{p_n}{q_n}} B_n = B_{n+1}^{-1} S_{\frac{p_n}{q_n}} B_{n+1}$ , and since, for  $n \geq 2$ ,  $\|\phi_n\|_{n+1} \leq q_n^{R_8(n)}$  for a sequence  $R_8(n)$  independent of  $q_n$  (because  $q_n \geq 2$  for  $n \geq 2$ ), we obtain, for a fixed sequence  $R_9(n)$  (that depends on  $n$  and on the dimension  $d$ ):

$$\begin{aligned}
d_n(T_{n+1}, T_n) &= d_n(B_{n+1}^{-1} S_{\frac{p_{n+1}}{q_{n+1}}} B_{n+1}, B_{n+1}^{-1} S_{\frac{p_n}{q_n}} B_{n+1}) \leq C(k, d) \|B_{n+1}\|_{n+1}^{n+1} \left| \frac{p_{n+1}}{q_{n+1}} - \frac{p_n}{q_n} \right| \\
&\leq (\gamma_h^{(n+1)} q_n)^{R_9(n)} \left| \frac{p_{n+1}}{q_{n+1}} - \frac{p_n}{q_n} \right|
\end{aligned}$$

For some choice of the sequence  $R_1(n)$  in lemma 1.3, this last estimate guarantees the convergence of  $T_n$  in the smooth topology.

### 4.3.3 Ergodicity

Ergodicity is a property preserved by metric isomorphism. Therefore, to show that  $T$  is ergodic, it is sufficient to show that the limit translation  $T^\alpha$  on the torus  $\mathbb{T}^h$  is ergodic. We apply a theorem by Katok and Stepin [5]:

**Theorem 4.11** (Katok-Stepin [5]). *Let  $U$  be an automorphism of a Lebesgue space  $(N, \nu)$ , let  $(U_n)_{n \geq 1}$  be a sequence of measure-preserving transformations, and let  $(\chi_n)_{n \geq 1}$  be a sequence of finite measurable partitions of  $N$ . Suppose that:*

- $U_n$  permutes the elements of  $\chi_n$  cyclically.
- $(\chi_n)_{n \geq 1}$  generates.
- $\sum_{c \in \chi_n} \nu(U(c) \Delta U_n(c)) = o(1/|\chi_n|)$  (where  $|\chi_n|$  is the cardinal of  $\chi_n$ ).

then  $U$  is ergodic.

Note that the sequence of partitions  $(\chi_n)_{n \geq 1}$  does not need to be monotonic. For our purpose, we cannot apply theorem 4.11 with  $\chi_n = \zeta_n$  or  $\zeta_n^\infty$ . Indeed, since  $p_n$  and  $q_n$  are not relatively prime in general (contrary to Anosov-Katok's original construction), then  $T_{\frac{p_n}{q_n}}^{\gamma^{(n)}}$  is not a cyclic permutation on  $\zeta_n$  nor  $\zeta_n^\infty$ , in general. Let  $g_n = \gcd(p_n, q_n)$  and

$$\hat{\Gamma}_{0,n} = \bigcup_{j=0}^{g_n-1} T^{j \frac{\gamma^{(n)}}{q_n}} \Gamma_{0,n}$$

We have the lemma:

**Lemma 4.12.** *Let  $\hat{\zeta}_n$  be the partition defined by:*

$$\hat{\zeta}_n = \left\{ \hat{\Gamma}_{i,n} = T^{i \frac{g_n \gamma^{(n)}}{q_n}} \hat{\Gamma}_{0,n}, i = 0, \dots, \frac{q_n}{g_n} - 1 \right\}$$

$T_{\frac{p_n}{q_n}}^{\gamma^{(n)}}$  is a cyclic permutation on  $\hat{\zeta}_n$ , and  $\hat{\zeta}_n$  generates.

*Proof.*  $T_{\frac{p_n}{q_n}}^{\gamma^{(n)}}$  is a cyclic permutation on  $\hat{\zeta}_n$  because  $g_n = \gcd(p_n, q_n)$ . Since  $q_n$  divides  $q_{n+1}$ , there is an integer  $e_{n+1}$  such that:

$$\frac{p_{n+1}}{q_{n+1}} - \frac{p_n}{q_n} = \frac{e_{n+1}}{q_{n+1}}$$

Since

$$\left| \frac{p_{n+1}}{q_{n+1}} - \frac{p_n}{q_n} \right| \leq \frac{1}{(\gamma_h^{(n+1)} q_n)^{R_1(n)}}$$

Then:

$$|e_{n+1}| \leq \frac{q_{n+1}}{(\gamma_h^{(n+1)} q_n)^{R_1(n)}}$$

Moreover, since  $(\gamma_h^{(n+1)} q_n)^{R_2(n)}$  divides  $q_{n+1}$ , and  $R_2(n) \geq 2$ , then  $\gcd(p_{n+1}, q_{n+1}/q_n) = \gcd(p_{n+1}, q_{n+1}) = g_{n+1}$ . Since

$$p_{n+1} - \frac{q_{n+1}}{q_n} p_n = e_{n+1}$$

then  $g_{n+1}$  divides  $e_{n+1}$ . In particular,  $g_{n+1} \leq |e_{n+1}|$ . By condition 7 of lemma 1.3, we get:

$$g_{n+1} \leq \frac{q_{n+1}}{(\gamma_h^{(n+1)} q_n)^{R_1(n)}} \leq \frac{q_{n+1}}{2^{n+1} \|\gamma^{(n+1)}\|}$$

Moreover, since:

$$\text{diam}(\Gamma_{0,n}) \leq \max\left(d_n, \frac{\|\gamma^{(n)}\|}{q_n}\right) \rightarrow_{n \rightarrow +\infty} 0$$

( $d_n = \text{diam}(\Gamma^{(n)})$ , where  $\Gamma^{(n)} \subset \mathbb{T}^{h-1} \times \{0\}$  is a fundamental domain of the flow  $\{T^t \gamma^{(n)}\}$ ) then:

$$\text{diam}(\hat{\Gamma}_{0,n}) \leq \max\left(d_n, \frac{g_n \|\gamma^{(n)}\|}{q_n}\right) \leq \max\left(d_n, \frac{1}{2^n}\right) \rightarrow_{n \rightarrow +\infty} 0$$

It shows that  $\hat{\zeta}_n$  generates.  $\square$

It remains to estimate  $\sum_{c \in \hat{\zeta}_n} \mu_h(T^\alpha c \Delta T^{\frac{p_n}{q_n} \gamma^{(n)}} c)$ . We have the lemma:

**Lemma 4.13.** *There is a choice of  $R_1(n)$  in condition 4 of lemma 1.3 such that:*

$$\sum_{c \in \hat{\zeta}_n} \mu_h(T^\alpha c \Delta T^{\frac{p_n}{q_n} \gamma^{(n)}} c) = o(g_n/q_n)$$

*Proof.* We have:

$$\sum_{c \in \hat{\zeta}_n} \mu_h(T^\alpha c \Delta T^{\frac{p_n}{q_n} \gamma^{(n)}} c) = \sum_{k \geq n} \sum_{c \in \hat{\zeta}_k} \mu_h\left(T^{\frac{p_{k+1}}{q_{k+1}} \gamma^{(k+1)}} c \Delta T^{\frac{p_k}{q_k} \gamma^{(k)}} c\right) = \sum_{k \geq n} \sum_{c \in \hat{\zeta}_k} \mu_h\left(T^{\frac{p_{k+1}}{q_{k+1}} \gamma^{(k+1)} - \frac{p_k}{q_k} \gamma^{(k)}} c \Delta c\right)$$

Let  $\tau_n$  be the  $(h-1)$ -volume of the border of an element of  $\hat{\zeta}_n$ . We have:

$$\mu_h\left(T^{\frac{p_{k+1}}{q_{k+1}} \gamma^{(k+1)} - \frac{p_k}{q_k} \gamma^{(k)}} c \Delta c\right) \leq \tau_k \left\| \frac{p_{k+1}}{q_{k+1}} \gamma^{(k+1)} - \frac{p_k}{q_k} \gamma^{(k)} \right\| = \tau_k \left\| \left( \frac{p_{k+1}}{q_{k+1}} - \frac{p_k}{q_k} \right) \gamma^{(k+1)} \right\|$$

Moreover,  $\tau_n$  is polynomially controlled by  $\gamma^{(n)}$  ( $h$  is fixed). Therefore, there is a choice of  $R_1(n)$  such that:

$$\sum_{c \in \hat{\zeta}_n} \mu_h(T^\alpha c \Delta T^{\frac{p_n}{q_n} \gamma^{(n)}} c) = o(g_n/q_n)$$

$\square$

By combining lemmas 4.12 and 4.13, and by applying theorem 4.11, we obtain that there is a choice of  $R_1(n)$  such that  $T^\alpha$  is ergodic.

#### 4.4 Extension to more general manifolds

To extend the construction from  $M = [0, 1]^{d-1} \times \mathbb{T}$  to a general  $d$ -dimensional smooth compact connected manifold, admitting an effective volume-preserving circle action, we proceed as in [3, p. 1805], but we give more details. Let  $\hat{S}$  be this effective circle action on  $M$ ,  $S$  be the circle action on  $[0, 1]^{d-1} \times \mathbb{T}$ . For  $q \geq 1$ , let  $F_q$  be the set of fixed points of  $\hat{S}_{1/q}$ . Let  $B = \partial M \cup_{q \geq 1} F_q$  be the set of exceptional points. We recall the proposition:

**Proposition 4.14** ([3]). *Let  $M$  be a  $d$ -dimensional smooth compact connected manifold, with an effective circle action  $S$ , preserving a smooth volume  $\mu$ . Let  $S_t$  denote the circle action on  $[0, 1]^{d-1} \times \mathbb{T}$ . There exists a continuous surjective map  $\Gamma : [0, 1]^{d-1} \times \mathbb{T} \rightarrow M$  such that:*

1. *the restriction of  $\Gamma$  to  $]0, 1[^{d-1} \times \mathbb{T}$  is a smooth diffeomorphic embedding.*
2.  $\mu(\Gamma(\partial([0, 1]^{d-1} \times \mathbb{T}))) = 0$
3.  $B \subset \Gamma(\partial([0, 1]^{d-1} \times \mathbb{T}))$
4.  $\Gamma_*(Leb) = \mu$
5.  $\hat{S}\Gamma = \Gamma S$

*Proof of lemma 1.3 for a general  $M$ .* We apply this proposition at each step in lemma 1.2: we have that  $\Gamma : ]0, 1[^{d-1} \times \mathbb{T} \rightarrow E = \Gamma(]0, 1[^{d-1} \times \mathbb{T})$  is a diffeomorphism. Let  $\Gamma^{-1}$  its inverse. We need the claim:

**Claim 4.15.** *Let  $\hat{T}_n : M \rightarrow M$  defined by  $\hat{T}_n(x) = \Gamma B_n^{-1} S_{\frac{p_n}{q_n}} B_n \Gamma^{-1}(x)$  if  $x \in E$  and  $\hat{T}_n(x) = \hat{S}_{\frac{p_n}{q_n}}(x)$  otherwise.  $(\hat{T}_n)_{n \geq 0}$  is a sequence of smooth diffeomorphisms converging towards a smooth diffeomorphism  $\hat{T}$  in the smooth topology.*

*Proof.*  $\hat{T}_n$  is bijective,  $\hat{T}_n|_E$  and  $\hat{T}_n|_{E^c}$  are smooth diffeomorphisms. Moreover, on a neighborhood  $G_n$  of  $\partial([0, 1]^{d-1} \times \mathbb{T})$  inside  $[0, 1]^{d-1} \times \mathbb{T}$ , and stable by the flow  $S_t$ ,  $B_n = B_n^{-1} = Id$ . Therefore, for  $x \in \Gamma(G_n) \subset E$ ,

$$\hat{T}_n(x) = \Gamma B_n^{-1} S_{\frac{p_n}{q_n}} B_n \Gamma^{-1}(x) = \Gamma S_{\frac{p_n}{q_n}} \Gamma^{-1}(x) = \hat{S}_{\frac{p_n}{q_n}} \Gamma \Gamma^{-1}(x) = \hat{S}_{\frac{p_n}{q_n}}(x)$$

Therefore,  $\hat{T}_n$  is a smooth diffeomorphism. Finally, the sequence  $\hat{T}_n$  smoothly converges towards a smooth diffeomorphism  $\hat{T}$ , by the same argument as for the proof of the convergence of  $T_n$  (for  $M = [0, 1]^{d-1} \times \mathbb{T}$ ). □

Let  $\hat{\xi}_n^\infty = \Gamma \xi_n^\infty$ . Since  $\Gamma$  is a diffeomorphism except on a set of zero Lebesgue measure, then the equivalent class of  $\hat{\xi}_n^\infty$  is a measurable partition. Moreover, since  $\Gamma$  is independent of  $n$ , then the sequence  $\hat{\xi}_n^\infty$  generates. Moreover,  $\hat{T}_n$  is  $\mu$ -measure preserving, stabilizes  $\hat{\xi}_n^\infty$  (because  $\hat{T}_n = \Gamma B_n^{-1} S_{\frac{p_n}{q_n}} B_n \Gamma^{-1}$   $\mu$ -almost everywhere) and by claim 4.15,  $\hat{T}_n$  weakly converges towards an automorphism of  $M$   $\hat{T}$ . Let  $\hat{K}_n^\infty = \Gamma \bar{K}_n^\infty$ . We have  $\bar{K}_n^\infty T_{\frac{p_n}{q_n}}^{\gamma^{(n)}} = \hat{T}_n \hat{K}_n^\infty$  and  $\hat{K}_{n+1}^\infty|_{\mathcal{G}_n^\infty} = \hat{K}_n^\infty$ . This allows to apply lemma 1.2, and combined with claim 4.15, we obtain lemma 1.3 for a general  $M$ . □

## References

- [1] D.V. Anosov and A.B. Katok. New examples in smooth ergodic theory. Ergodic diffeomorphisms. *Trans. Moscow Math. Soc.*, 23(1):35, 1970.
- [2] B. Fayad and M. Saprykina. Weak mixing disc and annulus diffeomorphisms with arbitrary liouville rotation number on the boundary. *Annales scientifiques de l'Ecole normale supérieure*, 38(3):339–364, 2005.
- [3] BR Fayad, M. Saprykina, and A. Windsor. Non-standard smooth realizations of Liouville rotations. *Ergodic Theory and Dynamical Systems*, 27(06):1803–1818, 2007.
- [4] PR Halmos. Lectures on ergodic theory. Chelsea Publishing. 1956.
- [5] A.B. Katok and A.M. Stepin. Approximations in ergodic theory. *Russian Mathematical Surveys*, 22(5):77–102, 1967.
- [6] B. Weiss. The isomorphism problem in ergodic theory. *American Mathematical Society*, 78(5), 1972.