



HAL
open science

Fully Polarimetric Ground Penetrating Radar WISDOM

Dirk Plettmeier, Valérie Ciarletti, Ph. Cais, Wolf-Stefan Benedix, Christophe Statz, Stephen Clifford, Svein-Erik Hamran

► **To cite this version:**

Dirk Plettmeier, Valérie Ciarletti, Ph. Cais, Wolf-Stefan Benedix, Christophe Statz, et al.. Fully Polarimetric Ground Penetrating Radar WISDOM. EPSC-DPS Joint Meeting 2011, Oct 2011, Nantes, France. 6, pp.EPSC-DPS2011-1762, 2011. hal-00664257

HAL Id: hal-00664257

<https://hal.science/hal-00664257>

Submitted on 30 Jan 2012

HAL is a multi-disciplinary open access archive for the deposit and dissemination of scientific research documents, whether they are published or not. The documents may come from teaching and research institutions in France or abroad, or from public or private research centers.

L'archive ouverte pluridisciplinaire **HAL**, est destinée au dépôt et à la diffusion de documents scientifiques de niveau recherche, publiés ou non, émanant des établissements d'enseignement et de recherche français ou étrangers, des laboratoires publics ou privés.

Fully Polarimetric Ground Penetrating Radar WISDOM

Dirk Plettmeier (1), Valerie Ciarletti (2), Philippe Cais (3), Wolf-Stefan Benedix (1), Christoph Statz (1), Stephen Clifford (4), Svein-Erik Hamran (5) and the WISDOM team
(1) Technische Universität Dresden, Germany, (2) Université Versailles St-Quentin; CNRS/INSU/LATMOS-IPSL, France, (3) Observatoire de Bordeaux, France, (4) Lunar and Planetary Institute, Houston, USA, (5) Forsvaretsforskningsinstitutt, Kjeller, Norway (dirk.plettmeier@tu-dresden.de)

Abstract

The Ground Penetrating Radar (GPR) WISDOM is designed to be part of 2018 ExoMars Rover payload. The main scientific objective of WISDOM is to characterize the material distribution within the first few meters of the Martian subsurface and to search for evidence of past and present life on Mars. The WISDOM radar will provide a penetration depth of about 3 meters with a resolution of a few centimetres within the Martian soil. A preliminary “real time” subsurface analysis supports the drill operations in finding places of high scientific interest and low risk. The joint data interpretation together with the drill team will significantly support the radar calibration. This presentation will focus on instrument performance depending on the accommodation of the WISDOM antennas aboard a Mars rover. Preliminary tests in the lab and in the field have shown that apart from the electronic unit the fully polarimetric antenna arrangement is one key element for the localization and characterization of buried scatterers and for the construction of a three dimensional subsurface map of the shallow Martian ground.

1. Introduction

The WISDOM (Water Ice Subsurface Deposit Observation on Mars) GPR is one of the instruments selected to be part of the Pasteur payload of ESA’s 2018 ExoMars Rover mission [1]. The main scientific objectives of the Pasteur payload are to search for evidence of past and present life on Mars and to characterise the nature of the shallow subsurface. WISDOM is capable of obtaining subsurface information along the rover path before drilling and to explore the first ~ 3 meters of the soil with a vertical resolution of a few centimetres, in accordance with the objectives and expected capabilities of the drill. WISDOM will help identify the location of sedimentary layers, where organic molecules are the most likely to be found and well-preserved. By investigating geometry and properties of buried reflectors,

WISDOM will contribute to the understanding of the 3D geological structure, electromagnetic nature, and, possibly, the state of water and ice in the shallow subsurface. WISDOM measurements will be performed 1) by conducting periodic soundings along the Rover traverse, which will provide a coarse, non-uniform, but positionally well-determined investigation of the landing site and 2) by selected high-resolution surveys of areas of strong scientific interest, which are identified for potential investigation and sampling by the Rover’s drill. Such surveys will generally be conducted by acquiring a number of closely spaced parallel profiles. Supported by specific hardware features, like the arrangement of the fully polarimetric antenna system, an interpolated 3-D subsurface map of the local stratigraphy can be constructed from these radar measurements.

A description of the WISDOM experiment with a particular emphasis on the specific antenna design chosen to meet the challenging technical objectives will be shown in this presentation. The influence of the antenna accommodation and corresponding interferences caused by the rover and the target itself will be discussed. Some preliminary validation measurements obtained with a prototype and with a fully representative of the flight model (form/fit/function) will be shown to illustrate the instrument’s potential performance.

2. Instrument Architecture

The WISDOM instrument hardware consists of the electronic unit inside the rover body, and the antenna unit [2] mounted in the rear of the rover, facing down towards the Martian surface.

As shown in the functional block diagram (Fig. 1), the electronic unit acts as a frequency modulated continuous wave (FMCW) radar. The radar controller generates a set of 501 frequencies ranging from 500 MHz up to 3 GHz, which corresponds to a step width of 5 MHz. The output power delivered by the transmitter is between +10dBm and +20dBm. Polarization switches can select 4 different polariza-

tion scenarios, 2 perpendicular co-polarization and 2 cross polarization measurements.

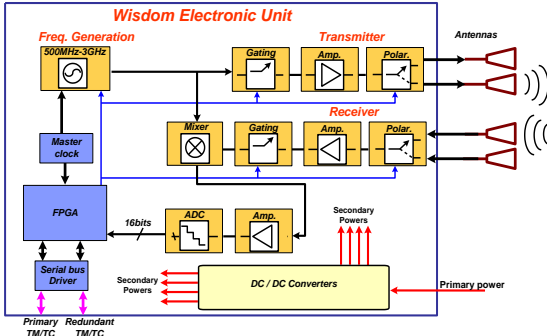

Fig. 1: Functional block diagram of the instrument.

The received signal is amplified, down converted, filtered and analog to digital converted by the homodyne receiver concept shown in Fig. 1. Hardware gating and coherent addition of the received signal are performed on board. Further basic signal processing, like Hilbert transformation and windowing, will be part of the post-processing on ground. Figure 2 shows photos of the electronic box and the antenna unit mounted on a rover mock-up.

2. Antenna Accommodation

Antenna design and accommodation have significant influence on the instrument performance. Usually, GPR antennas are placed directly on the ground or mounted just a short distance above it, with respect to the wavelength. Due to the design of the Mars rover, the GPR antenna system will have to deal with a ground clearance of 30 to 60 cm, which is equal to 3 to 6 wavelengths at WISDOM's highest operating frequency. This distance to ground will lead to an increased field of view, lower gain inside the dielectric medium, free space loss and significant radiation coupling effects between parts of the rover and the



Fig. 2: Electronic Unit (left) and antenna system mounted on a rover mockup (right).

antennas. Computer simulations and preliminary measurements have been performed on a rover mock-

up to characterize the antenna system in possible positions and orientations on the rover.

3. Field Tests

In addition to the lab measurements in the anechoic chamber and some tests with an earlier prototype of the WISDOM radar in Svalbard, preliminary field tests in particularly simple environments have been initiated with the electronic unit and antenna units built for the PDR. The resulting instrument is fully representative of the flight model (form/fit/function) and was firstly tested with well-known targets (like metallic spheres and plates) and is now being tested in a series of field campaigns in Mars-analog environments.

4. Conclusions

The WISDOM GPR has been successfully designed. The stringent requirements of the ExoMars mission, explicitly the high spatial resolution of a few centimeters in the near Martian sub-surface together with the reduced allocation for mass, volume, energy/power budgets as well as the additional constraints due to planetary protection issues made the development of the instrument challenging. Even if the optimization of the instrument is still on going, preliminary tests have shown that WISDOM meets the requirements and shows an instrument performance that is in several points better than expected. On-going work on the instrument performance is currently addressed to a possibility to take advantage of the antenna dual structure to perform antenna beam steering. Further work is on-going on the numerical simulations of backscattered signals for different soil compositions, on the signal analysis and on the system calibration.

Acknowledgements

WISDOM development and research were supported by funding from the French space agency CNES and from the German space agency DLR.

References

- [1] Ciarletti et al., "WISDOM GPR Designed for Shallow and High-Resolution Sounding of the Martian Subsurface", Proceedings IEEE, Volume 99, Issue 5 May 2011.
- [2] D. Plettemeier et al., "Full polarimetric GPR antenna system aboard the ExoMars rover", Proceedings IEEE, Radar Conference, Pasadena 4-8 May 2009.