



**HAL**  
open science

## Edge Preservation in Ikonos Multispectral and Panchromatic Imagery Pan-sharpening

Miloud Chikr El-Mezouar, Nasreddine Taleb, Kidiyo Kpalma, Joseph Ronsin

► **To cite this version:**

Miloud Chikr El-Mezouar, Nasreddine Taleb, Kidiyo Kpalma, Joseph Ronsin. Edge Preservation in Ikonos Multispectral and Panchromatic Imagery Pan-sharpening. 1st Taibah University International Conference on Computing and Information Technology, Mar 2012, Al-Madinah Al-Munawwarah, Saudi Arabia. 6 p. hal-00662437

**HAL Id: hal-00662437**

**<https://hal.science/hal-00662437>**

Submitted on 24 Jan 2012

**HAL** is a multi-disciplinary open access archive for the deposit and dissemination of scientific research documents, whether they are published or not. The documents may come from teaching and research institutions in France or abroad, or from public or private research centers.

L'archive ouverte pluridisciplinaire **HAL**, est destinée au dépôt et à la diffusion de documents scientifiques de niveau recherche, publiés ou non, émanant des établissements d'enseignement et de recherche français ou étrangers, des laboratoires publics ou privés.

# Edge Preservation in Ikonos Multispectral and Panchromatic Imagery Pan-sharpening

Miloud Chikr El-Mezouar, Nasreddine Taleb  
Djillali Liabes University of Sidi Bel Abbas  
Dept. of Electronics, RCAM Laboratory,  
Sidi Bel Abbas, Algeria  
{chikrelmezouar , ne\_taleb}@univ-sba.dz

Kidiyo Kpalma, Joseph Ronsin  
UEB INSA IETR Groupe Image et Télédétection  
CS 70839 35708  
Rennes Cedex 7, France  
{Kidiyo.Kpalma , Joseph.Ronsin}@insa-rennes.fr

**Abstract**—In Ikonos imagery, both multispectral (MS) and panchromatic (PAN) images are provided with different spatial and spectral resolutions. Multispectral classification detects object classes only according to the spectral property of the pixel. Panchromatic image segmentation enables the extraction of detailed objects, like road networks, that are useful in map updating in Geographical Information Systems (GIS), environmental inspection, transportation and urban planning, etc. Therefore, the fusion of a PAN image with MS images is a key issue in applications that require both high spatial and high spectral resolutions. The fused image provides higher classification accuracy. To extract, for example, urban road networks in pan-sharpened images, edge information from the PAN image is used to eliminate the misclassified objects. If the PAN image is not available, then an edge map is extracted from the pan-sharpened images, and therefore the quality of this map depends on the fusion process of PAN and MS images. In a pan-sharpening process, before fusing, the MS images are resampled to the same pixel sizes as the PAN images and this upsampling impacts subsequent processing. In this work, we demonstrate that the interpolation method, used to resample the MS images, is very important in preserving the edges in the pan-sharpened images.

**Keywords**- *pan-sharpening; edge detection; interpolation; Ikonos imagery*

## I. INTRODUCTION

Earth observation satellites provide multispectral and panchromatic data having different spatial, spectral, temporal, and radiometric resolutions. The fusion of a panchromatic (PAN) image having high spatial and low spectral resolutions with multispectral (MS) images having low spatial and high spectral resolutions is a key issue in many remote sensing applications that require both high spatial and high spectral resolutions. The fused image may provide feature enhancement, classification accuracy increase, and may be of great help in change detection. Hence, there is an increasing use of image processing techniques to combine the available multispectral images and PAN images. These techniques are known as pan-sharpening or resolution fusion techniques. In

practical applications, the Intensity-Hue-Saturation (IHS) approach is the most widely used [1].

The extraction of road networks is useful for cartography, traffic management, map updating in Geographical Information Systems (GIS), environmental inspection, transportation and urban planning, etc. The result of road extraction from high-resolution satellite imagery is suitable for large-scale urban applications, such as updating road networks of large-scale topographical maps and GIS. Additionally, the high temporal resolution makes the satellite images ideal sources for change detection and damage assessment. In [2], to extract urban road networks, a conventional multi-spectral classification of a Pan-sharpened image is firstly conducted. Then the classified road network is refined, by eliminating all the misclassified objects, using the edge information from the PAN image. In [3] an automatic road extraction algorithm for urban area from multi-spectral Ikonos imagery was developed. The “road edge” is used to validate the extraction at the decision level.

Most of the proposed methods make use of edge information which is provided by the pan-sharpened images or directly by PAN images if available. This will improve the classification process. In this work, we analyze the impact of interpolation on the quality of the fused images. Generally, simple interpolation techniques are not satisfactory due to the creation of visual artifacts like pixelization, jagged contours and over-smoothing. In order to better preserve the edge we use the Fast Artifacts-Free Image Interpolation technique proposed in [4]. For comparison purposes, we use the conventional IHS fusion method with two interpolation techniques. We then compare the results using some pan-sharpening evaluation indexes and the Canny edges obtained from the PAN and the two fused images.

## II. STANDARD IHS FUSION SCHEMEN

The Intensity-Hue-Saturation (IHS) color space decouples the intensity (I) component from the color-carrying components (H and S) in a color image. The hue is an attribute that describes a pure color (e.g., pure yellow, orange, or red), whereas saturation gives a measure of the degree to which a pure color is diluted by white light. The intensity represents the

total amount of the light in a color and usually appears like a PAN image. Hence, the IHS transform is widely used as an image fusion technique. The main steps, illustrated in Fig. 1, of the standard IHS fusion scheme are:

- 1) Convert MS from RGB into IHS,
- 2) Replace the ‘I’ component with PAN, and
- 3) Convert it back to RGB.

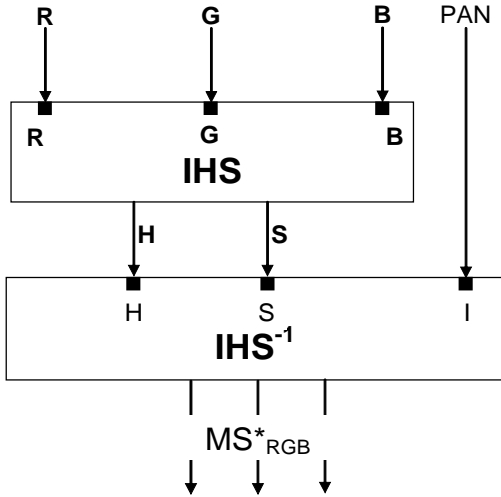

Figure 1. Standard IHS fusion scheme

Before the fusion process, the color image should be registered to the high-resolution PAN image [5] and resampled to the same pixel size as the PAN image.

### III. INTERPOLATION METHOD

In pan-sharpening, the commonly used linear interpolation methods, such as bilinear and bicubic, have advantages in simplicity and fast implementation. However, they suffer from some inherent defects, including block effects, blurred details and ringing artifacts around edges. The human visual systems are highly sensitive to edge structures, so preserving edge structures is a challenge in image interpolation [6].

The interpolation method proposed in [4] is called ICBI (Iterative Curvature Based Interpolation). It is based on the combination of two different procedures. First, an adaptive algorithm is applied interpolating locally pixel values along the direction where the second order image derivative is lower. Then the interpolated values are modified using an iterative refinement minimizing differences in the second order image derivatives, maximizing second order derivative values and smoothing isolevel curves. The first algorithm itself provides edge-preserved images that are measurably better than those obtained with similarly fast methods presented in the literature. The full method provides interpolated images with a “natural”

appearance that do not present the artifacts affecting linear and nonlinear methods.

The results of this interpolation method obtained on a wide series of natural images are attractive. Hence, we have decided to use this method in the fusion process to preserve edges in the pan-sharpened images.

## IV. EXPERIMENTAL SETTINGS, RESULTS AND EVALUATION

### A. Quality Assessment Indexes

The quality assessment of Pan-sharpened MS images is a difficult task. Even when reference MS images are available for comparison with fusion results, the assessment of fidelity to the reference usually requires computation of a number of different indexes.

The authors in [7] recently proposed a categorization of indexes found in the literature based on their properties, complementarities, and redundancies. Following their recommendations, we have selected the following list of indexes. For each spectral band, we compute: the *bias* in relative value, the *difference in variance* in relative value, the *standard-deviation* of the differences on a pixel basis in relative value, the *correlation coefficient* and the *correlation between high frequencies*. For the whole data set, we compute the average spectral angle mapper (*SAM*) and the relative dimensionless global error in synthesis (*ERGAS*).

1). *Bias, variance (VAR) and the standard deviation (SD)*: The bias is the difference between the mean of the original image and that of the fused one. In the relative value, the bias is divided by the mean of the original image. The relative variance is the difference in variance between the original and the fused images, divided by the variance of the original image. The ideal value for each of these measures is zero. The standard deviation of the difference image in relation to the mean of the original image indicates the level of the error at any pixel. The lower the value of SD, the better the spectral quality of the fused image.

2). *Correlation*: The correlation coefficient (CC) is the most popular. It shows the similarity in small size structures between the fused and original pixels. It is defined as:

$$CC(x/y) = \frac{\sum_{i=1}^M \sum_{j=1}^N (x_{i,j} - \bar{x})(y_{i,j} - \bar{y})}{\sqrt{\sum_{i=1}^M \sum_{j=1}^N (x_{i,j} - \bar{x})^2 \sum_{i=1}^M \sum_{j=1}^N (y_{i,j} - \bar{y})^2}} \quad (1)$$

Where (MxN) is the size of the images and  $\bar{x}$  and  $\bar{y}$  stand for the mean values of the two images x and y between which the correlation is computed and CC is calculated globally for the entire image. A CC value of +1 indicates that the two images are highly correlated.

To evaluate similarities between spatial details, a high-pass filter is applied to the images and then the CC between the resulting images is computed. This quantity is also called spatial correlation coefficient sCC. The high correlation coefficients between the fused filtered image and the reference filtered one (sCC) indicate that most of the spatial information of the reference image was incorporated during the merging process. The sCC has the same definition as the CC. The ideal value is 1.

3). *The spectral angle mapper (SAM)*: It has been widely used in multispectral and hyperspectral image analysis to measure spectral similarity between substance signatures for material identification. To compute the SAM between two images, each having  $L$  bands  $B$ , two spectral vectors  $v$  and  $w$  are constructed, both having  $L$  components, where  $v = \{v_1, v_2, \dots, v_L\}$  with  $v_k = B^{(k)}(i, j)$  corresponding to pixel  $(i, j)$  in the  $k^{\text{th}}$  original band, while  $w = \{w_1, w_2, \dots, w_L\}$  with  $w_k = \text{Fused\_B}^{(k)}(i, j)$  corresponding to pixel  $(i, j)$  in the  $k^{\text{th}}$  fused band. The SAM takes the arccosine of the dot product between the two spectral vectors as:

$$SAM(v, w) = \cos^{-1} \left( \frac{\sum_{i=1}^L v_i w_i}{\sqrt{\sum_{i=1}^L v_i^2} \sqrt{\sum_{i=1}^L w_i^2}} \right) \quad (3)$$

SAM is usually averaged over the whole image to yield a global measurement of spectral distortion. Small angles indicate high similarity and high angles indicate low similarity.

4). *The ERGAS*: This index provides a single quantity synthesizing the quality of the fused data set. In image fusion, the index of the “erreur relative globale adimensionnelle de synthèse (ERGAS)” (meaning relative global adimensional synthesis error) is as follows:

$$ERGAS = 100 \frac{h}{l} \sqrt{\frac{1}{L} \sum_{i=1}^L \frac{RMSE^2(B_i)}{\mu_i^2}} \quad (4)$$

Where  $h$  is the resolution of the high spatial resolution image,  $l$  is the resolution of the low spatial resolution image,  $\mu_i$  is the mean radiance of each spectral band  $B_i$  and  $L$  is the number of the bands involved in the fusion. RMSE is the root mean square error between a reference image and a fused image. The lower the value of the ERGAS, the higher the spectral quality of the fused image.

5). *The edge error*: Moreover, we propose to compare the edge information obtained from applying Canny’s edge detector [8] to the PAN image and the fused results corresponding to the bicubic and ICBI interpolations. For the edge-detected map from each fused image, we compute the number of pixels not belonging to the edge map of the PAN

image. Then we divide this number by the total number of the edge pixels in the PAN image to obtain what we call the edge error. It is clear that the edge error measures the missed and the added edges (fantom edges) compared to the reference PAN edge image. If the fused edge image preserves exactly the same PAN edge then the edge error equals zero.

### B. Experimental settings

The fusion and quality assessment algorithms were implemented in Matlab. However, the program code of the ICBI method, used in this experiment, was downloaded from the author’s web page [9].

### C. Experimental results and evaluation

An image scene on Mt. Wellington, Tasmania, Australia, taken by the Ikonos satellite sensor on January 2005 is used for this experiment. The size of the original PAN image is approximately 12000×13000 pixels from which we extract portions for our experiments. Before the image fusion, the multispectral images were co-registered to the corresponding PAN image and resampled to the same pixel size as the PAN image using the two interpolation methods.

In table I, we present the comparison results for two images with size 1024x1024 for the fused results, corresponding to Fig. 2 and Fig. 3. As can be seen on these figures (Fig. 2(f) and Fig. 3(f)), the ICBI-based results preserve clearly the original PAN edge by producing a zero edge error. In addition this method provides better values in terms of most of the pan-sharpening evaluation indexes.

TABLE I. A COMPARISON OF IMAGE FUSION USING THE BICUBIC AND ICBI INTERPOLATIONS FOR TWO IKONOS TEST REGIONS

		Set 1		Set 2	
		Bicubic	ICBI	Bicubic	ICBI
BIAS	R	0.0330	<b>0.0133</b>	<b>0.2034</b>	0.2287
	G	<b>0.0007</b>	0.0550	<b>0.2458</b>	0.2787
	B	<b>0.0102</b>	0.0409	<b>0.2768</b>	0.3081
VAR	R	0.3882	<b>0.3272</b>	0.1155	<b>0.0471</b>
	G	0.3591	<b>0.2946</b>	0.1975	<b>0.1258</b>
	B	0.4376	<b>0.3561</b>	0.0273	<b>0.0216</b>
SD	R	<b>0.2609</b>	0.2651	<b>0.2810</b>	0.2848
	G	<b>0.2762</b>	0.2804	<b>0.2996</b>	0.3044
	B	0.3167	<b>0.3148</b>	<b>0.3465</b>	0.3535
CC	R	0.7274	<b>0.7375</b>	0.7793	<b>0.7841</b>
	G	0.6994	<b>0.7106</b>	0.7631	<b>0.7711</b>
	B	0.6639	<b>0.6834</b>	0.6885	<b>0.6923</b>
sCC	R	0.9938	<b>0.9962</b>	0.9953	<b>0.9963</b>
	G	0.9938	<b>0.9950</b>	0.9966	<b>0.9975</b>
	B	0.9939	<b>0.9957</b>	0.9960	<b>0.9963</b>
SAM		7.6420	<b>6.2503</b>	6.0748	<b>5.5250</b>
ERGAS		10.8373	<b>10.6809</b>	<b>12.5027</b>	12.8319
Edge error		0.0615	<b>0.0000</b>	0.0746	<b>0.0000</b>

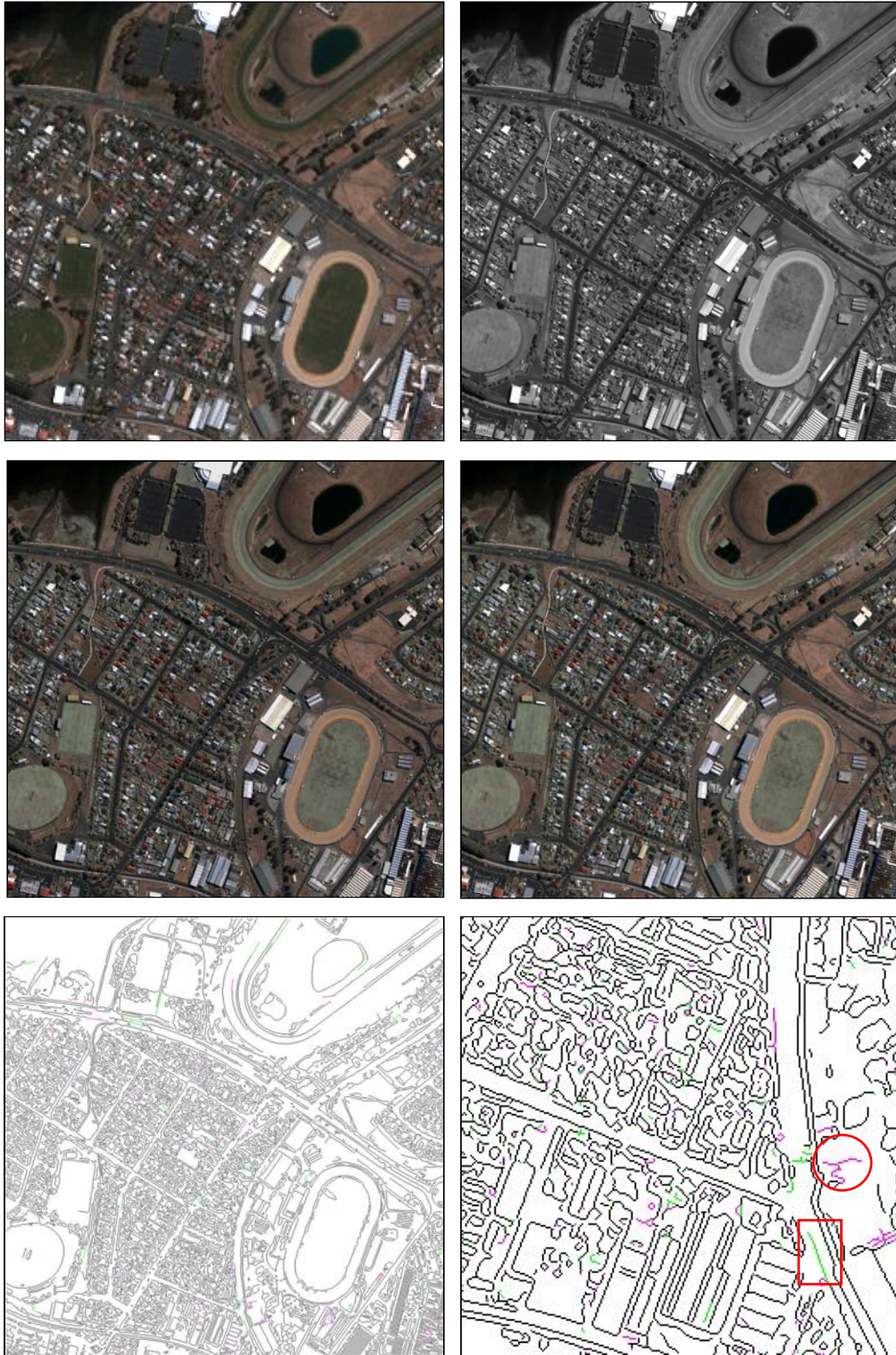

Figure 2. Set 1, from top to bottom and from left to right: (a) low-resolution RGB image. (b) Corresponding PAN image. (c) Fused result using Bicubic interpolation. (d) Fused result using ICBI interpolation. (e) Edge information visualized as RGB image, where channels R, G and B correspond to images shown in (b), (c) and (d) respectively. (f) An area of (e).

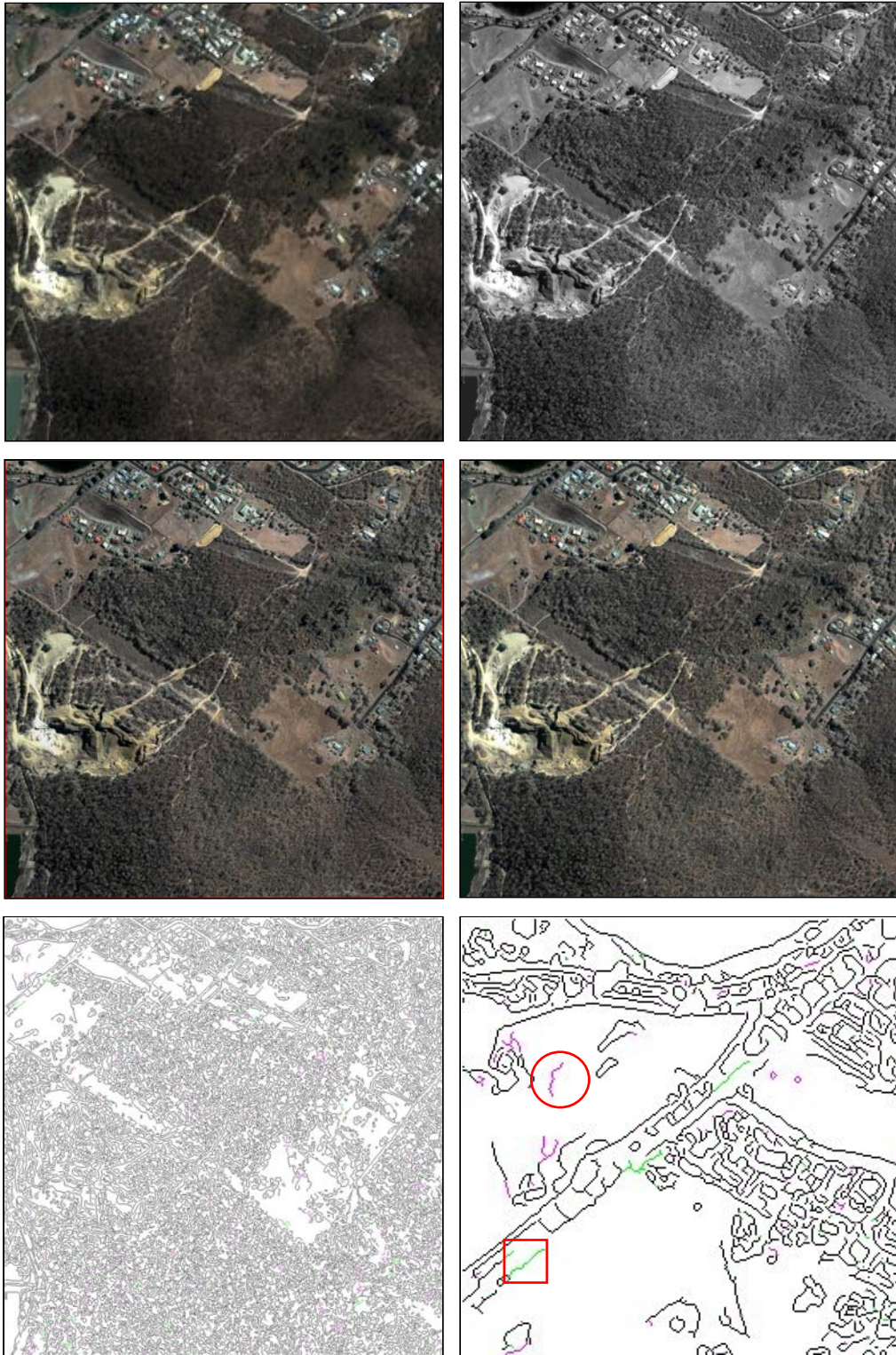

Figure 3. Set 2, from top to bottom and from left to right: (a) low-resolution RGB image. (b) Corresponding PAN image. (c) Fused result using Bicubic interpolation. (d) Fused result using ICBI interpolation. (e) Edge information visualized as RGB image, where channels R, G and B correspond to images shown in (b), (c) and (d) respectively. (f) An area of (e).

The results presented in Fig. 2 and Fig. 3 show vegetation color degradations in the fused images, this is due to the use of the IHS fusion scheme on Ikonos images [1]. These degradations are important in applications of vegetation extraction [10], visualization or enhancement [1]. In this work, we are more interested to preserve the edge information in the pan-sharpened images provided from the PAN images.

Hence we compare the same method with two different interpolation techniques. The fused results using the bicubic and the ICBI interpolation methods are shown in (c) and (d), respectively, for the two images of Fig. 2 and Fig.3. Fig. 2e and Fig. 3e illustrate the edges of the PAN image, of the fused image using the bicubic interpolation and of the fused image using the ICBI interpolation.

When a pixel belongs to the PAN edges and to the edges from both fused images, it is displayed in black color. The purple color (circles) shows the edge pixels detected in the PAN and ICBI-based fused images.

The green color (rectangles) illustrates the edge pixels detected in the bicubic-based fused image only. In other words, the purple color corresponds to the missed edges and the green color to the added edges provided by the bicubic-based fused image.

Fig.2(f) and Fig.3(f) are 256x256 pixels parts from the whole 1024x1024 pixel images in Fig.2(e) and Fig.3(e), respectively. We can see that the bicubic-based fused results miss some edges which may be important in many applications like road extraction. Moreover added edges (or phantom edges) are observed. These false edges can easily distort the results, especially when the edges are the only tool to make a decision.

#### A. CONCLUSION

In this work, we have used the IHS fusion method to produce the pan-sharpened Ikonos images. We have considered two interpolation methods, the bicubic method as a standard technique and a more sophisticated one that is the ICBI approach. The obtained results clearly show that the ICBI-based fused images give very good results, both visually and quantitatively. Moreover, the edges are totally preserved in the ICBI-based fused images and this is an interesting aspect since it may be important, especially when the user does not have the PAN image.

In future works, one can integrate more interpolation methods in more advanced fusion techniques in order to choose the best interpolation method which deals with pan-sharpening.

#### ACKNOWLEDGMENT

Imagery courtesy of Space Imaging LLC.

#### REFERENCES

- [1] M. Chikr El-Mezouar, N. Taleb, K. Kpalma, and J. Ronsin, "An IHS-Based Fusion for Color Distortion Reduction and Vegetation Enhancement in IKONOS Imagery," *IEEE Trans. Geosci. Remote Sens.*, vol. 49, pp. 1590 – 1602, May 2011.
- [2] R. Wang and Y. Zhang, "Extraction of urban road network using Quickbird Pansharped Multispectral and Panchromatic Imagery by Performing Edge-Aided Post-Classification" . *ISPRS Joint Workshop on Spatial Temporal and Multi-Dimensional Data Modeling and Analysis*, October, 2-3, 2003, Quebec, Canada.
- [3] Y. Luo, Y. Xue and S. Zhong, "Road extraction from IKONOS image using grid computing platform," in *Proc. IEEE IGARSS '05*, vol. 6, pp. 3895 – 3898, 2005.
- [4] A. Giachetti and N. Asuni, "Fast artifacts-free image interpolation," in *Proc. of the British Machine Vision Conf*, Sept. 2008, pages 123--132.
- [5] Y. Bentoutou, N. Taleb, K. Kpalma, and J. Ronsin, "An Automatic Image Registration for Applications in Remote Sensing," *IEEE Transactions on Geoscience and Remote Sensing*, vol. 43, pp. 2127 – 2137, Sep. 2005.
- [6] X. Li, and M. T. Orchard, "New edge-directed interpolation," *IEEE Trans. Image Process.* Vol. 10, pp. 1521-1527, 2001.
- [7] C. Thomas and L. Wald, "Comparing distances for quality assessment of fused products," in *Proc. 26th EARSeL Annu. Symp. New Develop. Challenges Remote Sens.*, Warsaw, Poland, May 29–31, 2006. Z. Bochenek, Ed., Rotterdam, The Netherlands: Balkema, 2007, pp. 101 – 111.
- [8] J.F. Canny, "A computational approach to edge detection," *IEEE Trans Pattern Analysis and Machine Intelligence*, 8(6): pp. 679-698, Nov 1986.
- [9] A. Giachetti. (2008) program download web page. [Online]. Available: <http://www.andreagiachetti.it/icbi/> (Last accessed in Jan 2012).
- [10] M. Chikr El-Mezouar, N. Taleb, K. Kpalma and J. Ronsin, "Vegetation extraction from IKONOS imagery using high spatial resolution index", *J. Appl. Remote Sens.* 5, 053543 (Aug 11, 2011)