



HAL
open science

Children recognize emotions of EmI companion robot

Sébastien Saint-Aimé, Brigitte Le Pevedic, Dominique Duhaut

► **To cite this version:**

Sébastien Saint-Aimé, Brigitte Le Pevedic, Dominique Duhaut. Children recognize emotions of EmI companion robot. IEEE Robio-2011, IEEE International Conference on Robotics and Biomimetics, Dec 2011, Thailand. hal-00661775

HAL Id: hal-00661775

<https://hal.science/hal-00661775>

Submitted on 20 Jan 2012

HAL is a multi-disciplinary open access archive for the deposit and dissemination of scientific research documents, whether they are published or not. The documents may come from teaching and research institutions in France or abroad, or from public or private research centers.

L'archive ouverte pluridisciplinaire **HAL**, est destinée au dépôt et à la diffusion de documents scientifiques de niveau recherche, publiés ou non, émanant des établissements d'enseignement et de recherche français ou étrangers, des laboratoires publics ou privés.

Children recognize emotions of EmI companion robot

Sébastien Saint-Aimé and Brigitte Le Pévédic and Dominique Duhaut

Abstract— This article presents the evaluation of the emotional expressiveness of EmI companion robot in the EmotiRob project. We describe iGrace emotional computational model of emotion to generate an emotional response based on the speech of the interlocutor, the mechanical design and implementation of EmI, and experimentation to evaluate the expressiveness of EmI with 52 school children aged 7 to 9 years.

I. INTRODUCTION

A new challenge in Robotics is to create systems capable of behaviour enhancement due to their interaction with humans. Research work in psychology has shown that facial expressions play an essential role in the coordination of human conversation [1] and constitute an essential modality in human communication. Among the different experiments in this field, the first work of Shibata [2] et Breazal [3] clearly showed that companion robots could give a certain amount of moral and psychological comfort to those that are most vulnerable. Robots can play a role of both companionship and stimulation.

In this context, the MAPH project objective is to design an autonomous stuffed robot with expressiveness, which may bring some comfort to vulnerable children (eg, children in long hospital stay). The EmotiRob project, which is a subproject of MAPH, aims to equip the robot with the perception and understanding capabilities of natural language so that it can react to the emotional state of the speaker. EmotiRob also includes the conception of a model for the emotional states of the robot and its evolution.

The first section presents iGrace computational emotional model and the different hypotheses we have used. The second section describe briefly robotics and computational conception of EmI robotic platform. The third section present the experimentation we began with children and EmI to evaluate its facial expressions.

II. MODÈLE CALCULATOIRE DES ÉMOTIONS

I-GRACE

iGrace computational model [4], [5], instance of the generic model GRACE [6], [7], to have a nonverbal emotional reaction to the speech of the speaker. It receives input

This work was not supported by ANR and regional council of Martini-que

Sébastien Saint-Aimé is with VALORIA Computer Science laboratory, University of Bretagne Sud, 56000 Vannes, France sebastien.saint-aime@univ-ubs.fr

Brigitte Le Pévédic is with VALORIA Computer Science laboratory, University of Bretagne Sud, 56000 Vannes, France brigitte.le-pevedic@univ-ubs.fr

Dominique Duhaut is with VALORIA Computer Science laboratory, University of Bretagne Sud, 56000 Vannes, France dominique.duhaut@univ-ubs.fr

informations, processes them and determines behavior than can have EmI for the discourse. iGrace is composed with 3 principal parts allowing information processing :

- "Input" Module : result from understanding module, it informs "emotional interaction" about the speech of the user.
- "Emotional interaction" Module : with informations given by "Input" and cognitive state of EmI, it generates an emotional state representing by a list of emotional experiences.
- "Expression of emotions" Module : express emotional state of EmI calculated by "Emotional Interaction".

A. Input

This module represents the interface for communication and data exchange between the understanding module and emotional interaction module. The parameters taken into account are the following :

- Video signal
- Audio signal
- 7-uplets of understanding module :
 - Actions "for the child"
 - Concepts "for the child"
 - Act of language
 - Coherence
 - Tense
 - Phase
 - Emotional state

B. Emotional Interaction

This process objective is to generate the emotional state of EmI with informations of the discours given by "Input" and its internal cognitive state. It builds a list of emotional experiences for EmI based on a taxonomy of emotions : emotional experiences [8]. "Emotional Interaction" is composed of four main modules that produce lists L_i of pairs ($eemo, C(eemo)$) involving an emotional experience $eemo$ with an influence coefficient $C(eemo)$ in four steps (see Fig. 2) :

- Moderator : represents cognitive internal emotional state of EmI. It builds a list L_{mod} of emotional experiences functions of EmI personality and mood.
- Emotional experiences selector : represents emotional state of EmI for the discourse. It builds a list L_{sel} of emotional experiences functions of the words of the discourse.
- Emotional experiences generator : represents emotional state of EmI functions of cognitive internal emotional

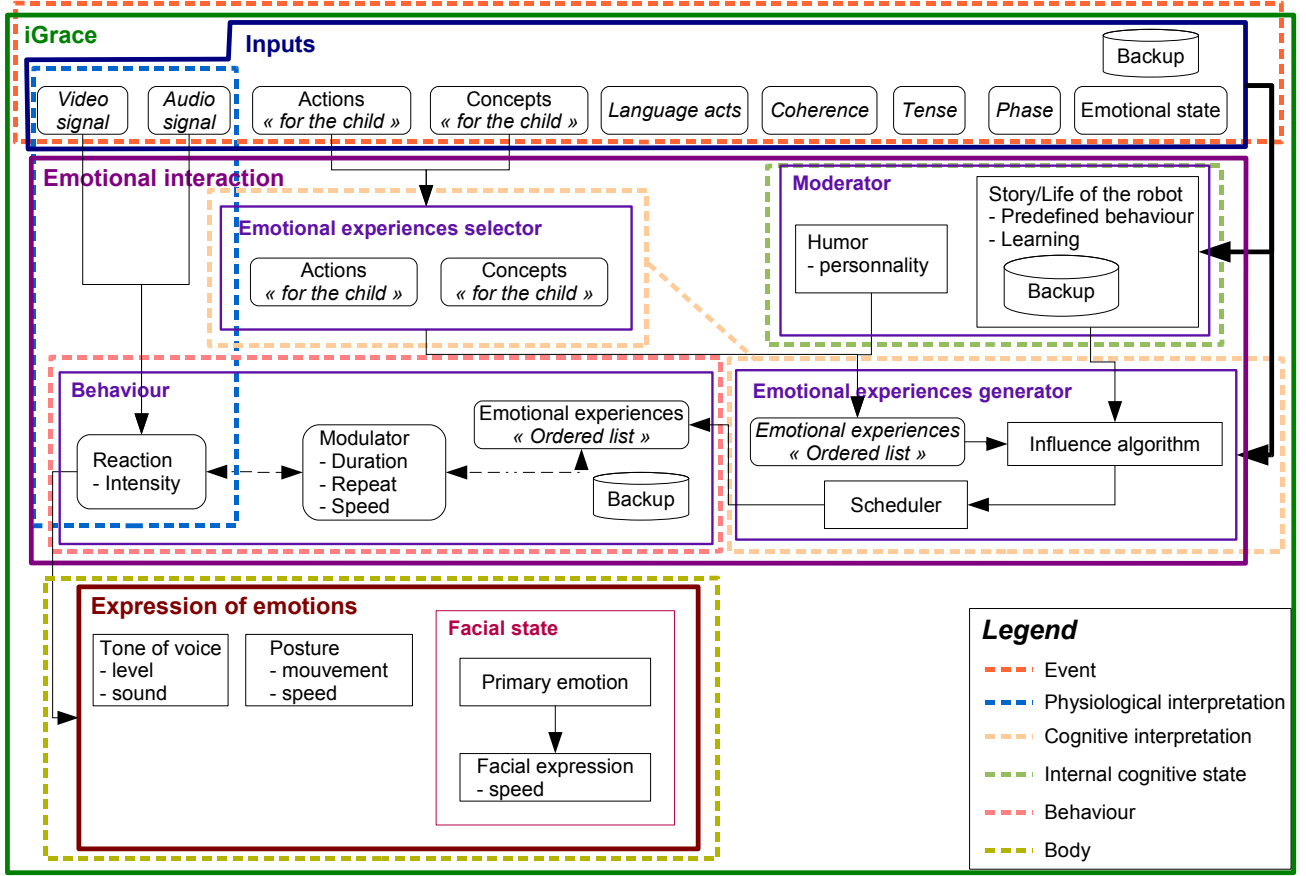

Fig. 1. iGrace computational model of emotions

state of EmI, emotional state of the user and for the discourse. It builds, in first time, a list L_{etat} of emotional experiences functions of emotional state of the child. Then it builds a list L_{gen} by fusion of all list : L_{mod} , L_{sel} , and L_{etat} .

- Behaviour : chooses reaction of EmI among these proposed by *emotional experiences generator*. It extracts the best emotional experiences in the list L_{gen} to L_{comp} .

C. Expression of emotions

This process objective is to express emotional state of EmI by building a list of triplet $\langle \text{tone, posture, facial state} \rangle$. Because EmI can only express the six primary emotion of P. Ekman, we convert emotional experiences of the list L_{comp} in facial expression. A matrix EM defines relation between emotions and emotional experiences of the list L_{comp} . These emotions allow us choose a facial expression in a large panel.

Emotional state expression is realize functions of features of EmI : buzzer and motors. These informations are convert into actions that can be execute by EmI. Facial expressions and postures are convert into motors movements and tone into music notes. Facials expressions for an emotion is expressed with 6 action units. We use a simple simplification of EMFACS system [9], [10].

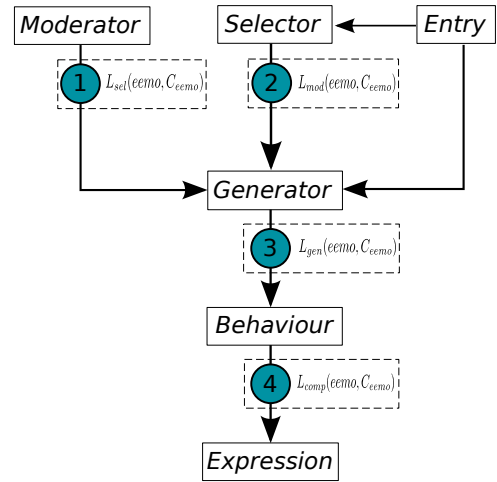

Fig. 2. Processing of event from understanding module in 4 steps

III. ROBOTIC CONCEPTION

After an advanced research study on perception and emotional synthesis, we determine the most appropriate way to express emotion and have a good recognition of expression with our users. The first steps of the project [11] allowed us to determine the degrees of freedom required to express the

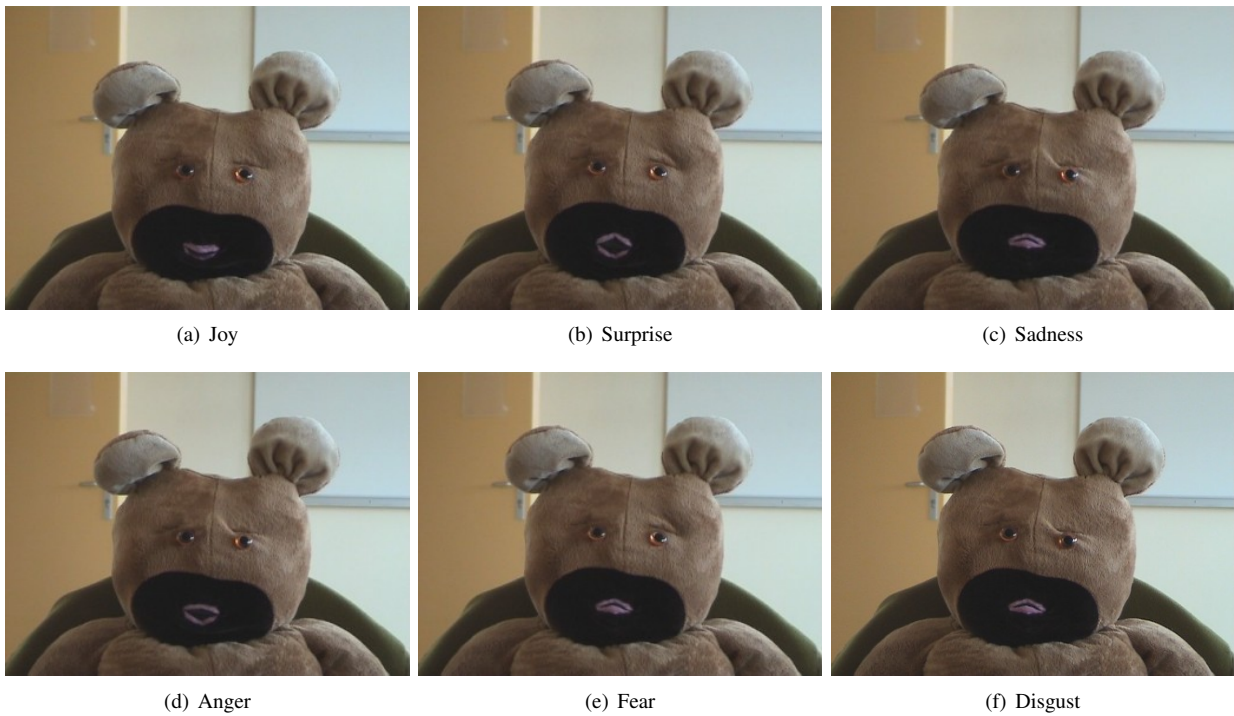

Fig. 3. Exemples of faciales expressions for the third version of emI

six primary emotions of P. Ekman [12] and then start robotic conception.

A. Mechanical architecture

EmI robotic platform we built is a stuffed animal with a pleasant texture that can emotionnally react by using facial expressions and body movements. Research work on emotional synthesis allowed us to know differents elements that make up the face and number of degrees of freedom necessary for facial expression of 6 primaries emotions of P. Ekman. The face of the robot is composed of the following elements :

- 1 mouth : 4 degrees of freedom.
 - 2 eyebrows : 2 degrees of freedom (1 per eyebrow).
- To these elements of the face, we add :
- 2 ears fixed.
 - 2 yeux fixed.
 - 1 camera at nose level to follow the face and potentially for facial recognition. The camera used is a CMUCam 3.

The material used for the skeleton of the head is made with epoxy resin allowing for better resistance. Movement of facial elements is made through a cable system (see Fig. 4) and springs to improves the expressiveness of the robot(see Fig. 3, videos can be downloaded on Website of the project¹). The system used for the mouth is a spring system surrounded by a very elastic fabric

To increase the expressiveness of the robot, we associate body movements to facial expressions. The architecture

1. <http://www-valoria.univ-ubs.fr/emotirob/>, menu Robot -> Vidéo

allows the following movements :

- For the head : 2 degrees of freedom for movement right - left and up - down.
- For the waist, 2 degrees of freedom for movement right - left and up - down.

The skeleton of the torso is made of aluminium and allows the robot to turn its head from left to right, as well as up and down. It also permits the same movements at the waist. There are a total of 4 motors that create these movements.

The motors used for the head are AX-12+ and for the torso RX-24 (powerful). These motors allow a numerical communication with the computational architecture we do. Actually the weight of EmI is about 2,8 Kg.

To allow EmI play an emotional song, we substitute one of the motors (AX-12+) of the face by an AX-S1. This motor incorporates new features like temperature and infrared sensors, a buzzer for some music notes, etc.

B. Computer architecture

Currently, communication with the robot is done through a distant computer directly hooked up to the motors. This computer integrated a process called *iGrace*, like the computational model of emotion we develop. This process is develop with C++ language and uses a FTDI library for communication with motors. This library allows send (and receive) instructions packets with identification of the motors, action to do and parameters for this action. The link between motors and the computer (see Fig. 5) is do with USB cables. The 6 motors for the head use a TTL connection and these for the torso RS-485. We need use an USB2Dynamixel convertor for USB \leftrightarrow TTL and USB \leftrightarrow RS-485.

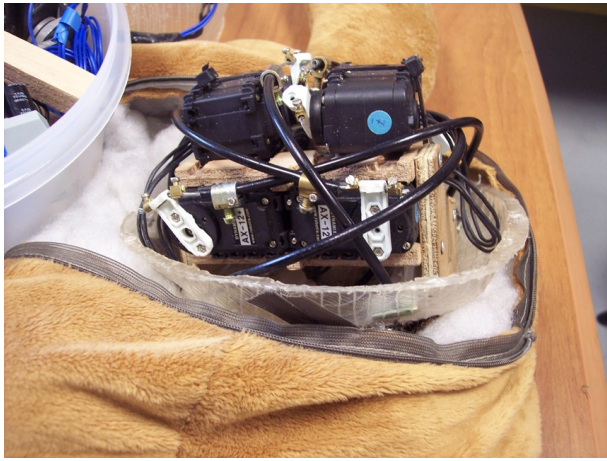

(a) Used of cables system with the motors



(b) EmI entier

Fig. 4. Realization of the third version of EmI

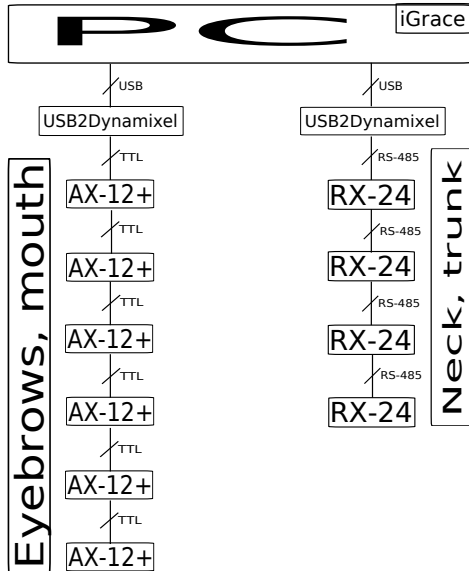

Fig. 5. Computer architecture for the third version of emI

IV. EMI EVALUATION

This experiment wants to evaluate the expressiveness of the latest version of EmI companion robot, its physical appearance and expressiveness. To evaluate these points, we ask 52 children (see Fig. 6) from primary school "Sacré Cœur" aged 7 to 9 years to interact with EmI and fill out an evaluation grid. For this experiment, we use the Wizard of Oz technique to simulate EmI behaviour. The sessions are videotaped with parental consent, so we can analyze data collected after the interaction. The explication of the experiment were given the day of the assessment by a team member (evaluator).

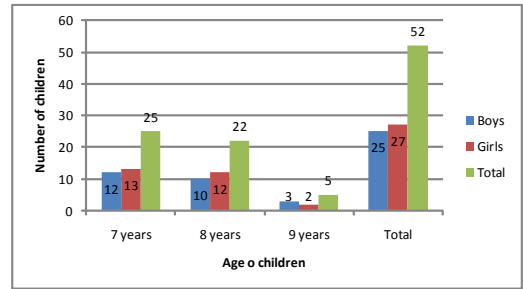

Fig. 6. Public for EmI evaluation

A. Protocol

The experiment takes place over two half days in a classroom including EmI, a group of 7 children (see Fig. 7), an evaluator and a technician (stayed in background) for EmI control. Before starting the sessions, EmI story is told to children and the purpose of his coming into their establishment. We will not forget to specify that EmI can not speak but can move the body, head, lips and eyebrows.



Fig. 7. Position of children during evaluation

The interaction is to read to each child a sentence to EmI, and then, note the emotion he thought he recognized. The seven sentences previously defined (see Table I) are distributed randomly. At the end of each spoken sentence,

2. École maternelle et primaire du Sacré Cœur, 8 rue des Vénètes, 56000 Vannes.

the seven children have to check on the evaluation grid the emotion they have recognized.

TABLE I
SENTENCES FOR WITCH EMI HAD A REACTION

Phrase	Émotion
Emi you are pretty	Joy
Emi, we love you so much	Joy
I'm coming with a car this morning	Neutral
I have watched TV last night	Neutral
My brother is playing with an elephant	Surprise
I drive a flying car	Surprise
You are so ugly Emi	Sadness
Emi, i don't love you	Sadness
Emi, i'll tear your teddy	Anger
Emi, i have eat all your candy	Anger
I like to eat slugs and toads	Disgust
I've brought a cauliflower yogurt	Disgust
Emi, you have a spider on you head	Fear
Emi i will hit you	Fear

At the end of the sessions, children have the opportunity to handle and play with their new companion (see Fig. 8). They can now see how it moves and be comfortable with him. This operation takes about 10 minutes and allows us to complete the third part of the grid on the evaluation of the physical aspect of the robot.



Fig. 8. Two children kissing EmI after evaluation

B. Evaluation grid

Evaluation grid gives information about recognized emotions by the children during interaction with EmI. It is composed with 14 rows of 8 cases, each row representing a sentence. The first 7 cases contain a face expressing an emotion (the six primary emotions : joy, sadness, anger, surprise, disgust, fear + neutral expression), the 8th case allows the child to indicate that he has not recognized an emotion.

C. Results and discussion

This experiment aims to evaluate the expressiveness of the new version of EmI by children. The Figure 9 presents recognition rates of emotions for 52 children. We notice the high overall recognition rate, which is satisfactory to

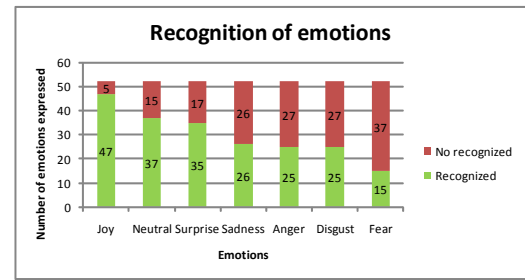

Fig. 9. Recognition rate of emotions

our users. However, some emotions are less recognized and confused.

Table II presents the existing confusion between different emotions. It appears that a better choice of facial expressions must be made to certain emotions, including anger. But improving the mechanical design must also be carried out, particularly on the expressive eyebrows, that would help to better recognition.

TABLE II
TABLE OF COMPARISON BETWEEN RECOGNIZED AND EXPRESSED EMOTIONS.

Émotions	Joy	Neutral	Surprise	Sadness	Anger	Disgust	Fear	Dont know
Joy	47	0	4	0	0	0	0	1
Neutral	1	37	4	0	1	1	0	8
Surprise	1	0	35	0	3	2	3	8
Sadness	0	7	2	26	15	0	0	2
Anger	3	0	8	6	25	1	5	4
Disgust	1	7	2	7	4	25	2	4
Fear	0	7	2	13	6	1	15	8

The other figures presents satisfaction rates for the physical aspect of EmI and the children interest for him, namely : the look, size and attachment. Figures 10 presents the satisfaction rate for the look.

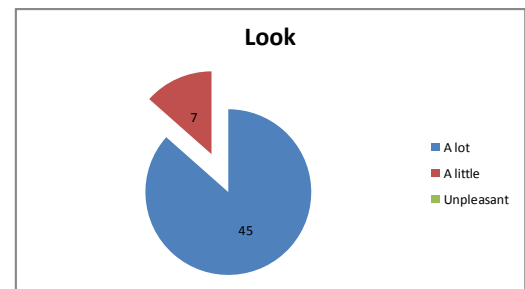

Fig. 10. Satisfaction rate for the look of EmI

Figures 11 et 12 present satisfaction rate for size and attachment.

These very high rates show that EmI is very well accepted by children.

In light of this evaluation, it appears that the new mechanical design choices increase the expressiveness of EmI. Even with a fairly low rate for anger emotion, the result is very satisfactory in its entirety. To validate and confirm our

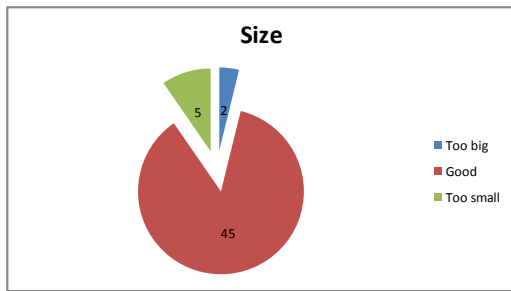

Fig. 11. Satisfaction rate for the size of EmI

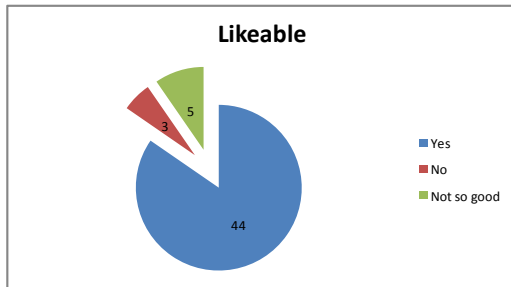

Fig. 12. Satisfaction rate for attachment with EmI

choice of design, a new experimentation will be made with a bigger number of children. This will be done under the same conditions and with the same robot.

V. CONCLUSIONS AND FUTURE WORKS

This article has presented expressiveness evaluation for EmI companion robot. To do this, an experiment was conducted with 52 children. It aimed to evaluate its physical aspect and emotional state expressed with an architecture using a mechanical cable system. The rates obtained showed good results for this latest version, allowing us to start a new experiment with EmI using iGrace computational model.

The computational model emotional iGrace we have developed is an instance of the generic model of emotions GRACE that defines the emotional process. iGrace process is based on the application of coefficients on lists of emotional experiences built from :

- internal cognitive state of EmI
- emotional state of EmI for the speech
- emotional state of the user

iGrace can generate an emotional state based functions of an event related speech of the user. This computational model has been integrated into the robotic platform EmI, now in its third version. Its evaluation will confirm the previous results.

VI. ACKNOWLEDGMENTS

EmotiRob is currently financed by the regional council of Martinique, for the development of the emotional synthesis, the regional council of Bretagne for language comprehension, and the ANR for the construction of the robot.

Most of all, we would like to thank the regional council of Martinique, as well as the ANR for their collaboration and the financing of future work.

The authors would also like to thank all participants for the time spent on this experiment and all constructive comments.

REFERENCES

- [1] E. A. Boyle, A. H. Anderson, and A. Newlands, "The effects of visibility on dialogue and performance in a cooperative problem solving task," *Language and Speech*, vol. 37, no. 1, pp. 1–20, 1994.
- [2] K. Wada, T. Shibata, T. Saito, and K. Tanie, "Effects of robot-assisted activity for elderly people and nurses at a day service center," *Proceedings of the IEEE*, vol. 92, no. 11, pp. 1780–1788, Nov. 2004.
- [3] C. Breazeal and B. Scassellati, "Infant-like social interactions between a robot and a human caretaker," *Adaptive Behavior*, vol. 8, no. 1, pp. 49–74, 2000.
- [4] S. Saint-Aimé, "Conception et réalisation d'un robot compagnon expressif basé sur un modèle calculatoire d'émotions," Ph.D. dissertation, Valoria – Université ed Bretagne Sud, Vannes, 9 juillet 2010.
- [5] S. Saint-Aimé, B. Le Pévédic, and D. Duhaut, *iGrace – Emotional Computational Model for EmI Companion Robot*. InTech Education and Publishing, 2009, ch. 4, pp. 51–76.
- [6] T.-H.-H. Dang, S. Letellier-Zarshenas, and D. Duhaut, "Comparison of recent architectures of emotions," in *Control, Automation, Robotics and Vision, 2008. ICARCV 2008. 10th International Conference on*, Decembre 2008, pp. 1976–1981.
- [7] —, "Grace – generic robotic architecture to create emotions," *Advances in Mobile Robotics : Proceedings of the Eleventh International Conference on Climbing and Walking Robots and the Support Technologies for Mobile Machines*, pp. 174–181, September 2008.
- [8] M. Larivey, *La puissance des émotions : Comment distinguer les vraies des fausses.*, de l'homme ed. Québec : Les éditions de l'Homme, 2002.
- [9] P. Ekman and W. Friesen, "EMFACS facial coding manual," *Human Interaction Laboratory, San Francisco*, 1983.
- [10] W. Friesen and P. Ekman, "EMFACS : Emotion facial action coding system," Available from W. Friesen, Department of Psychiatry, University of California, San Francisco, 1984.
- [11] S. Saint-Aimé, B. Le-Pévédic, and D. Duhaut, "Building emotions with 6 degrees of freedom," in *Systems, Man and Cybernetics, 2007. ISIC. IEEE International Conference on*, Oct. 2007, pp. 942–947.
- [12] P. Ekman, "Universal and cultural differences in facial expression of emotion," in *Nebraska Symposium on Motivation*, vol. 19, Nebraska University Press, 1972, pp. 207–283.