



**HAL**  
open science

## A New Wireless Architecture for In-Flight Entertainment Systems Inside Aircraft Cabin

Ahmed Akl, Thierry Gayraud, Pascal Berthou

► **To cite this version:**

Ahmed Akl, Thierry Gayraud, Pascal Berthou. A New Wireless Architecture for In-Flight Entertainment Systems Inside Aircraft Cabin. *International Journal On Advances in Networks and Services*, 2011, 4 (1&2), pp.159-175. hal-00661029

**HAL Id: hal-00661029**

**<https://hal.science/hal-00661029v1>**

Submitted on 18 Jan 2012

**HAL** is a multi-disciplinary open access archive for the deposit and dissemination of scientific research documents, whether they are published or not. The documents may come from teaching and research institutions in France or abroad, or from public or private research centers.

L'archive ouverte pluridisciplinaire **HAL**, est destinée au dépôt et à la diffusion de documents scientifiques de niveau recherche, publiés ou non, émanant des établissements d'enseignement et de recherche français ou étrangers, des laboratoires publics ou privés.

## A New Wireless Architecture for In-Flight Entertainment Systems Inside Aircraft Cabin

Ahmed AKL, Thierry GAYRAUD, and Pascal BERTHOU  
CNRS ; LAAS ; 7 avenue du Colonel Roche, F-31077  
Universite de Toulouse ; UPS, INSA, INP, ISAE ; LAAS ; F-31077  
Toulouse, France  
{aakl, gayraud, berthou}@laas.fr

**Abstract**—A primary difficulty when investigating communication requirements rises when a very specific field as an aircraft cabin is considered. The diverse needs of passengers are often incompatible to the strict constraints inside the cabin. Nowadays, *In-Flight Entertainment (IFE)* systems, for instance, are widely spread in modern flights. An IFE system usually consists of a Seat Electronic Box, the passengers terminal hardware, plus a Passengers Control Unit, the remote control to select the service, and a Visual Display Unit, the screen. Using the wireless technology in these systems can increase the satisfaction level of both the passengers and the avionics companies. However, the inside of the cabin is not a flexible environment; reliability and safety are two mandatory requirements, so different constrains are imposed. This means that off-shelf technologies (hardware including antennas, network topology, network protocols and services) are usually not suitable for such environment. Consequently, a new architecture has to be designed and implemented. This paper aims at integrating heterogeneous available communication technologies, showing their pros and cons, within this context, while considering the imposed communication restrictions inside the aircrafts cabin. From that, a new wireless heterogeneous architecture is proposed. In addition, to be able to use such architecture, we propose a new protocol, which utilizes the smart antennas technology to allow *Passenger Control Units* to be recognized and configured autonomously without any external intervention.

**Keywords**—*IFE system, Wireless networks, PLC, Smart antenna, Protocol engineering and evaluation*

### I. INTRODUCTION

In recent years, market surveys have revealed a surprising and growing trend in the importance of *In-Flight Entertainment (IFE)* with regard to choice of airline. With modern long range aircraft the need for "stop-over" has been reduced, so the duration of flights has also been increased. Air flights, especially long distance, may expose passengers to discomfort and even stress. IFE can provide stress reduction entertainment services to the passenger. The IFE system is an approach that can utilize the wireless technology for the purpose of exchanging data -in both directions- between passengers and the entertainment system. Although wired communication gives better performance than wireless communication, but most of modern personal devices are

based on the wireless technology, so providing wireless capabilities is essential for efficient utilization of these devices. Moreover, a wireless headphones is more satisfactory than a wired headset attached to the seat arm. We are not targeting to make the system fully wireless, but to emphasize the idea that different technologies can be used in the IFE system to improve the passenger's service satisfaction level [1].

As stated by Niebla [2], users are becoming more and more familiar to personal equipments, such as mobile phones, laptops, and PDAs. This shows the importance of providing aircrafts with facilities that support these equipments.

Nowadays, different wireless technologies with different capabilities exist in the market such as WiFi, Bluetooth, infrared, and Wireless Universal Serial Bus (WUSB). However, these technologies may have certain characteristics that make them unsuitable for usage inside the cabin. Although it was proven that WiFi and Bluetooth can be used inside the cabin with no fear of interfering with navigational equipments [3], it is still difficult to use them in large numbers since performance degrades due to allocating them in a small area inside a metallic tunnel (i.e., cabin), which is full of different obstacles (i.e., seats). In addition, the normal way of setting these technologies is usually done through predefined identifiers (i.e., IP address) or a user key (i.e., Bluetooth authentication key). Both techniques don't match the constrains inside the cabin, where devices must be designed without any predefined identifiers and to be configured without any user intervention

However, usage of the wireless technology will help in decreasing the connecting wires; this is a valuable criterion in aircrafts designing. Using off-shelf technologies inside the cabin is usually not applicable when using them in the usual manner; the environment inside the cabin has very strict constrains since safety is a major requirement. Consequently, using just one technology can't be the optimum solution. In fact, using a combination of different technologies can provide a better service while overcoming the existing constrains. The way passengers use their *Personal Electronic Devices (PED)* (i.e., mobile phones, laptop, etc.) was usually done through specialized devices [2], [3]. Nevertheless, there

is no current research to use a combination of off-shelf technologies inside the cabin.

The IFE market attracted many companies to submit different IFE solutions. *Thales* [4], an avionic systems provider, introduced its own IFE system that can be tailored according to the needs of the airlines companies. Some other companies provide dedicated solutions for certain parts of the IFE systems; the *AeroMobile* [5] is a GSM service provider for the aviation industry that allows passengers to use their mobile phones and devices safely during the flight. Passengers can connect to an AeroMobile pico cell located inside the craft which relays the text messages and calls to a satellite link which sends them to the ground network. The AeroMobile system manages all the cellular devices onboard, so signal strength can be kept at a minimum value to minimize interference. This system is adopted by Panasonic to be part of its in-flight cellular phone component. *FlyNet* [6] is an onboard communication service provided by Lufthansa to allow passengers to connect to the Internet during their flight.

In the next section, we will introduce an overview for the IFE system showing its components and requirements. Section II-C introduces the communication challenges that face the IFE systems. Section III shows the proposed available technologies that can be used to overcome the challenges in such environment. Section III-B introduces our approach for integrating them together. Section IV presents our proposed protocol that utilizes the smart antenna capabilities to connect the IFE devices. Section V shows how the protocol was verified and validated through a *Unified Modeling Language (UML)* model and NS2 simulation. Finally, we present the conclusion and future work.

## II. BACKGROUND AND RELEVANT WORK

The recognized economics of wireless networks and communications systems have made them an attractive target for environments where individual wires are cumbersome. An airplane cabin is such an environment. Dwayne [7] said that due to the need of rapidly reconfiguring the cabin's seating, it is further assumed that wireless networking, rather than cable or fiber optics, must be used to interconnect passenger's entertainment equipment with other elements of the system.

The use of wireless communication technologies on board of an aircraft provides an opportunity to remove wiring and save weight on the aircraft. The weight savings can be directly measured in terms of fuel savings and improved operating economics over the life time of an aircraft. However, there is a need to ensure that there is no interference with the aircraft's communication and navigation systems.

### A. The need for IFE systems

Hao [8] mentioned that the enclosed environment of the aircraft can cause discomfort or even problems to

passengers. IFE systems can greatly reduce these negative effects. This can be done by using e-books, video/audio broadcasting, games, internet, and On Demand services. The fact that passengers come from highly heterogeneous pools (such as age, gender, ethnicity, etc.) causes an impact on the adaptive interface systems.

As mentioned by Fariba [9], the IFE systems usually include screen-based, audio and communication systems. The screen-based products include video systems enabling passengers to watch movies, news and sports. These systems had progressed into video-on-demand, allowing passengers to have control when they watch movies. Air map display is another service that allows them to locate their flight's route. Exterior-view cameras also enable passengers to have the pilot's forward view on take-off and landing on their personal TV screens. Audio systems include different types of music channels and special programs recorded for the airlines. Communication systems include intra-communications with devices such as telephones, facsimile and in-seat power supplies, and inter-communications between the screen-based system and its subsystems (i.e., remote control).

### B. The IFE system's components

In fact, the entertainment starts from the passenger's seat design where most of the IFE system components are embedded. Wiring cables connect together all of the electronic devices in the seat as well as connecting them to the whole system in the cabin. They run through the cabin's walls, floor, and seats. Unfortunately, conveying signals and power to seats with a connector for each seat would cause reliability and maintenance problems, and hinder timely cabin reconfiguration.

Nowadays, IFE systems are interactive systems, so a *Passenger Control Unit (PCU)* is usually needed to control the surrounding devices. The PCU should be compact and easily held. Moreover, the pocket holding the PCU has to be placed in a way that makes it reachable and not to affect the passenger's comfort. At the beginning, PCUs used to be fixed aside to the *Visual Display Unit (VDU)* at the back of the front seat. This orientation introduced a problem when the passenger setting beside the window wants to move to the corridor; where all his neighbors have to replace their PCUs to allow him to pass. To overcome this problem, PCUs are now connected to their VDUs through wires passing via their seat.

A *Visual Display Unit (VDU)* is usually fixed to the back of the front seat. Depending on the required features of the system, ordinary displays can be used to display the visual contents or touch screens can be installed to act as input devices. Another orientation is to be fixed in the ceiling as a shared display for a group of seats.

A *Seat Electronic Box (SEB)* can be used to connect the system's different components together. It is used to connect the passenger's devices and the IFE system instead of having

a separate channel for each signal. For example, to transmit communication and video signals, two different networks should be available if the SEB is not used. When using the SEB, the communication and video devices are connected directly to it to convey signals to the rest of the IFE system through one single network. Then, it simplifies and facilitates maintenance procedure since malfunctioning devices can be easily replaced without affecting the IFE connections.

Halid [10] stated that *Power Line Communication (PLC)* can provide a way of communication through power lines networks. Power lines and communication networks have different physical characteristics, so a PLC modem must be used as an interface between the two networks. They must be designed to provide accepted network operation under typical power lines transmission conditions. However, power lines are not designed as a good transmission media. It suffers from attenuation, fading, and noise. Nevertheless, the great advances in digital signal processing, error detection and correction, modulation, media access control techniques encourage the use of PLC in communication field.

A part from the physical requirements of an IFE system, there are especial operational requirements to cope with its expected functionality.

- *Self configuration:* The system's units must be self configurable without any external intervention [11]. They must start, run, and cope with any changes in the system autonomously since the crew members are too busy to handle such operations; and even if they have the time and effort, they may lack the required technical background.
- *Minimized wiring and power consumption:* As mentioned before, these are valuable criteria in aircrafts' designing where wiring is considered as excess weight that can be expressed in terms of excess fuel consumption. Castagne [12] addressed the effect of weight over the *Direct Operating Costs (DOC)* by calculating the impact of weight increase on annual fuel consumption  $I_{DOC} = \frac{f_c \times n_{seat}}{W_{op}}$ , where  $f_c$  is the annual fuel consumption,  $n_{seat}$  is the number of seats,  $W_{op}$  is the operating weight. In fact, calculating the exact saved weight depends on various factors such as the cabin structure, cables routing, type of cables, etc. However, we can imagine the amount of saved weight through the contribution of Hurley [13]. He showed that cables flexibility is a design factor that affects cable routing; this means that cables may be extended through longer paths to reach its destination. Moreover, special jumpers and connectors are needed to attach cables, and groups of cables can be attached to a cable harness; this indicates that weight calculation will include the added weight of accompanied materials and equipments. It also indicates that wiring can hinder the maintenance process as well as imposing difficulties in changing the cabin's layout.

- *Easy to use:* Passengers of no knowledge about using modern technology must be able to use the system easily. For example, the PCU controls (i.e., Volume, Rewind, Forward, etc.) are known for almost everyone; especial purpose controls such as Settings, Mode, etc. can be carefully manipulated and, if used, to be provided by explanatory information when possible.
- *It has to be easily replaced:* In case of failure in one of the system's units, the unit has to be changed instantaneously and easily without the need of any technician, especially if the failure happened during the flight time.
- *Topology is not dynamic:* Once the network is setup, there will be no change in topology till the end of the flight unless a unit fails. In case of replacing a failed unit, it must be self configurable to join the network again. However, if passengers attached their PEDs to the system, some dynamism can be considered.
- *Scalability:* The system must be scalable to suit plans of different sizes and different seats layout.

### C. Communication challenges

Although aircraft security may be seen as another burden due to its very strict requirements, but it is mandatory to be included during the design of communication and data services. A major concern for using wireless devices in aircraft cabin is their interference with the aircraft's communication and navigation system, especially unintended interference from passenger's *Personal Electronic Devices (PED)*. Holzbock [14] said that the installed navigation and communication systems on the aircraft are designed to be sensitive to electromagnetic signals, so they can be protected against passenger's emitters by means of frequency separation. In addition, Jahn [3] mentioned that there are two types of PEDs' interference, intentional and spurious. The former is the emissions used to transmit data over the PED's allocated frequency band. The latter is the emissions due to the RF noise level.

Moreover, the existing systems suffer from bandwidth limitations; the trend toward bandwidth-consuming Internet services currently cannot be satisfied [3]. Passenger number and categories can be considered as a factor that affects network scalability. For example, the network bandwidth should be increased if the number of the first class passengers was increased to support the increasing need for video stream.

It is stated by Holzbock [14] that existing indoor channel models mainly investigate office or home environments, thus these models may not be appropriate for modeling an aircraft cabin channel. Attenuation of walls and multi path effects in a normal indoor environment are effects, which are not expected to be comparable to the effect of the higher obstacle density in a metallic tunnel. The elongated structure of a cabin causes smaller losses, than that expected in other type of room shapes. However, the power addition of local

signal paths can lead to fading of the signal in particular points. In addition, small movements of the receiver can have a substantial effect on reception. The same opinion was emphasized by Diaz [15].

Different efforts were held to overcome this problem, Youssef [16] used the commercial software package *Wireless Insite* to model the electromagnetic propagation of different wireless access points inside different types of aircrafts. Moraitis [17] held a measurement campaign inside a Boeing 737-400 aircraft to obtain a propagation development model for three different frequencies, 1.8, 2.1, and 2.45GHz which represent the GSM, UMTS, and WLAN and Bluetooth technologies, respectively. *Path Loss Modeling* was presented by the formula:

$$\overline{PL}(d) = FSL(d_o) + 10n \log_{10}\left(\frac{d}{d_o}\right) \text{ (dB)}$$

Where  $\overline{PL}(d)$  is the *average path loss* value in (dB) at a distance  $d$  in (m) from the transmitter to the receiver,  $FSL(d_o)$  is the *free-space path loss* in (dB) at a reference distance  $d_o$ , and  $n$  is the *path loss exponent* (decay rate). The wave-guide effect was expected to be noticeable since the cabin is considered as a long metallic tunnel. Thus, the value of  $n$  should be lower than 2. However, his measurements showed that  $n$  was found to be slightly larger than 2; showing that the wave-guide effect was counterbalanced. This is due to the thick carpet covering of the floor, non reflective textile covering the seats, and the gaps between rows of seats trap the transmitted rays. According to his measurements, he represented the *average seat inserting loss*  $\overline{L}_{seat}$  due to the backrests by the formula:

$$\overline{L}_{seat} = \frac{1}{N} \sum_{i=1}^N (\overline{PL}_i^{meas} - FSL_i) \text{ (dB)}$$

Where  $FSL_i$  is the *free-space loss* at the  $i$ -th seat,  $\overline{PL}_i^{meas}$  is the *average measured path loss* at the  $i$ -th passenger Seat, and  $N$  is the total number of seats

The effect of human presence inside the cabin over *Ultra Wide Band (UWB)* propagation was addressed by Chiu [18]. He considered three scenarios for placing the transmitter and receivers; *Ceiling to Headrest*, *Ceiling to Armrest*, and *Headrest to Armrest*; for each scenario the cabin was empty, partially filled, and fully filled with passengers. For the first two scenarios, the transmitter was mounted at the ceiling and receiving antennas were mounted at the headrest and armrest levels. For the last scenario, the transmitter was located at the headrest level, and the receiver was located at the armrest level. The measurements showed that the path gain dropped by no more than a few dB for the *Ceiling to Headrest* scenario. and dropped by up to 10 dB for the *Ceiling to Armrest* and *Headrest to Armrest* scenarios. The measurements concluded that the presence of human body

inside the cabin affects the wireless propagation and must be considered during wireless design.

Another challenge is that the cabin of an aircraft and the aeronautical environment in general define a very specific scenario that presents several constraints, which will affect the coverage and capacity planning. This is due to the fact that the space is very limited in an aircraft cabin, and its design allows installing equipment only in specific locations, where the configuration of the panels is easy to disassemble for maintenance [2]. Therefore, the replacement technique associated with the IFE system components, may affect the welling of the companies to use them. Replacing time consuming parts can lead to a long aircraft downtime or flight delays. Also, a device that fails during the flight, and is difficult to be replaced, will cause the passenger to be unsatisfied. Consequently, it is advisable to design components that are easily replaced with the minimum required technical skill.

### III. FROM COMMUNICATION TECHNOLOGIES TO HETEROGENEOUS ARCHITECTURE

As mentioned by Holzbock [14], wireless Cabin aims at developing a communication infrastructure consisting of heterogeneous wireless access networks to provide aircraft passengers and crew members with access to IFE system. Passengers are able to access different services through state-of-the-art wireless access technologies such as W-LAN IEEE802.11, and Bluetooth.

#### A. Available technologies

Regardless of different technologies available in the market, we are concerned with the ones that can be utilized inside the cabin

1) *Ethernet*: Ethernet is currently the standard for wired communication in different fields. Haydn [19] showed that it is characterized by interesting features such as good communication performance, scalability, high availability, and resistance to external noise. However, Ethernet cabling is considered a burden for aircraft design

2) *Wireless LAN*: WLAN is a well known technology used in different commercial, industrial, and home devices, and can easily coexist with other technologies to form a heterogeneous network [2]. Jim [20] stated that WLAN and Bluetooth technologies are two complementary not a competing technologies. They can cooperate together to provide users with different connecting services.

3) *Wireless USB*: *Universal Serial Bus (USB)* technology allows different peripherals to be connected to the same PC more easily and efficiently than other technologies such as serial and parallel ports. However, cables are still needed to connect the devices. This raised the issue of Wireless USB (WUSB) where the devices can have the same connectivity through a wireless technology. Neal [21] stated that although it is difficult to achieve a wireless performance similar to

wired USB, but the rapid improvements in radio communication can make WUSB a competent rival. It is based on the *Ultra Wide Band (UWB)* technology. In Europe, it supports a frequency range from 3.1 to 4.8 GHz. Moreover, Udar [22] mentioned that UWB communication is suitable for short range communications, which can be extended by the use of mesh networks. Although WUSB was designed to satisfy client needs, but it can also be used in a data centre environment. He discussed how WUSB characteristics can match such environment. This application can be of a great help in IFE systems, which strive to massive data communication to support multimedia services and minimizing the connection cables. Moreover, Jong [23] discussed the design issues related to WUSB. He stated that WUSB can support up to 480Mbps, but in real world it doesn't give the promised values; and he showed the effect of design parameters on the device's performance.

4) *Power Line Communication*: A PLC network can be used to convey data signals over cables dedicated to carry electrical power; where PLC modems are used to convert data from the digital signal level to the high power level; and vice versa. Using an existing wiring infrastructure can dramatically reduce costs and effort for setting up a communication network. Moreover, it can decrease the time needed for reconfiguring the cabin's layout since less cables are going to be relocated.

However, such technology suffers from different problems. A power line cable works as an antenna that can produce *Electromagnetic Emissions (EME)*. Thus, the PLC device must be *Electromagnetic Compatible (EMC)* to the surrounding environment. This means that it must not produce intolerable EME, and not to be susceptible to them. To overcome this problem, the transmission power shouldn't be high in order not to disturb other communicating devices [10]. However, working on a limited power signal makes the system sensitive for external noise. In spite of this, the PLC devices can work without concerns of external interference due to two reasons. Firstly, the PLC is divided into segments; this minimizes signal attenuation. Secondly, all the cabin's devices are designed according to strict rules that prevent EME high enough to interfere with the surrounding devices.

5) *Smart Antennas*: A smart antenna is a multi-element antenna where the emitted signal from each element can be controlled to direct the antenna's beam towards a certain direction as well as controlling the transmission power [24]. This feature is of great importance for ad-hoc networks domain where interference and power saving are two major issues.

Moreover, Okamoto [25] stated that smart antennas can provide the wireless environment with different advantages. First, it can significantly reduce the multi-path fading effect. Second, it minimizes the power consumption required for communication. Third, it can improve the system's *Signal-*

*to-Interference Ratio (SIR)*.

### B. The heterogeneous architecture

IFE system is a field starving for unusual ideas. Passengers can be satisfied by receiving services dedicated to a single user, but it will be more amusing if they can be offered services for multiple users, where passengers of similar interests can share their time. Using a single communication technology inside the cabin can't yield satisfactory results, but a combination of different technologies can have a great impact on the provided services.

The term heterogeneous in the networking domain usually implies the mix between wireless and wired networks. However, we mean by heterogeneity, the existence of different networking technologies cooperating together to achieve certain services. The network can be divided into *User Technology* and *System Technology*. A *User Technology* is the technology apparent and directly used by the user (i.e., Bluetooth, WiFi, etc.) to connect his devices to the system. A *System Technology* is the technology used by the system and is hidden from the user (i.e., PLC).

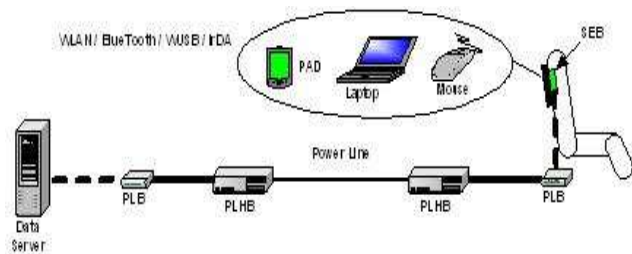

Figure 1. Heterogeneous network architecture

In our proposed heterogeneous architecture, we suggest the usage of a PLC network to convey data between a data server and the passengers' seats where he use his PEDs. In addition, wireless *Access Points (APs)* are connected to the PLC backbone as well; while WUSB is used to provide a way to connect some USB devices to the network (see Figure 1).

### C. Architecture evaluation

In this section, we will introduce some experimentation results to show the applicability of the proposed technologies for a cabin's IFE system

1) *PLC*: The proposed PLC system is shown in Figure 1; it consists of a *Power Line Head Box (PLHB)* and a *Power Line Box (PLB)*. The PLHB connects the two terminals of the power line to connect the data server with the seats. Each PLHB service a group of seats, which are equipped with PLB per seat. The PLB is responsible for distributing the signal received by the PLHB to the seat's SEB. both PLHB and PLB devices can be configured through their

internal web interface to define their IP address and other configuration parameters.

The MGEN (version 4.2) [26] traffic generator was used to emulate the traffic produced by the data server, and a laptop was used as a substitute to the SEBs. A traffic of 3480 bit/sec was used to represent each seat, so a total traffic of  $3480 \times 20$  bit/sec was injected into the PLHB. The target of the test was to collect different statistics to study the behavior of the PLC system by injecting periodic traffic flows at constant intervals.

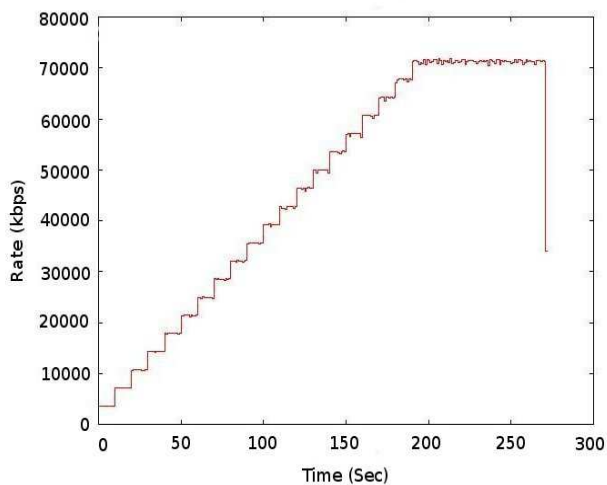

Figure 2. Flow rate of all flows

Figure 2 shows the sum of flows' rates. The stepping of the flow rate is constant indicating that the PLC connection is able to carry the injected traffic, and each PLHB can support up to 20 PLBs at a rate of 3480 bit/sec for each PLB. In addition, Figure 3 represents the packet count of the first flow. It is clear that the packet count stayed constant from the start to the end of the simulation without being affected by the injection of the subsequent flows. This emphasizes the same results derived from Figure 2.

However, it is normal to have packet dropping during transmission. Figure 4 shows the obtained loss fraction; it is less than 0.05, which can be considered as a good value. Such configuration can provide the IFE with a way to provide video services by using the existing power cabling.

2) *WLAN*: We held different NS2 [27] simulations to propose a good distribution for the wireless *Access Points* (APs) inside the cabin. We used the same cabin configuration used by Alexandaros [28]. The cabin consists of 26 rows with 6 seats each (3 on each side of the aisle); this gives a total of 156 seats. The cabin is 21m long and 3.54m wide. The rows' separation distance is 81cm. By default, NS2 uses the standard 802.11 protocol which supports 2Mb rate. We used the more reliable 2Mb physical layer than the upper

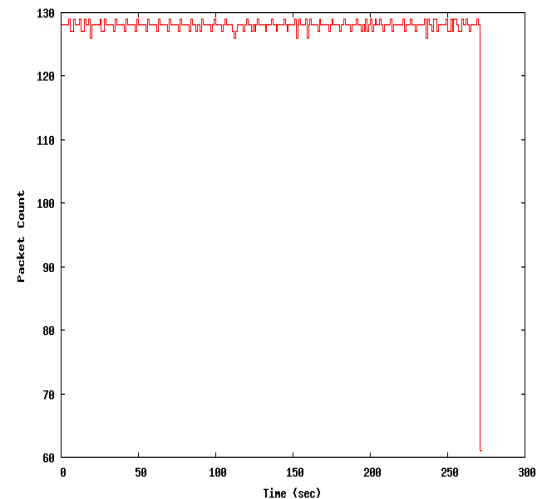

Figure 3. Packet count of the first flow

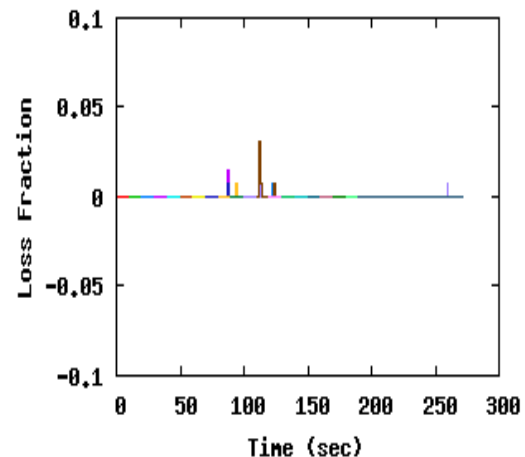

Figure 4. Loss Fraction

standard (i.e., 802.11b,g) since the transmission environment inside the cabin is not optimum.

A wireless node - representing a passenger's device - is located at the position of each seat, and APs are used to connect them with the data server. Using a large number of wireless devices in a very narrow metallic tunnel like the cabin has a dramatic effect on the network's performance. For this reason, we are studying the effect of using frequency separation between APs. However, we need to determine the minimum number of APs required to cover the whole cabin, and their distribution inside the cabin, so we experimented with three scenarios. In scenario 'A', all nodes (each has a transmission range covering the whole cabin) are using the same communication channel. Scenario 'B' uses nodes

with short transmission range, which allows connection only to the nearest Access Point (AP), while using the same channel. Scenario 'C' shows nodes with short transmission range and using channel separation. The channel separation in the third scenario is based on the fact that 802.11 only allows the usage of three non interfering channels (i.e., channels 1, 6, and 11). The impact of the three scenarios over average throughput, average delay, and number of transmitted packets is studied.

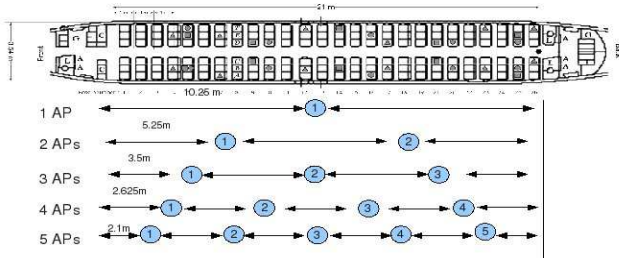

Figure 5. APs distribution

Each scenario was repeated 5 times while using different numbers of Aps located at the aisle. We started by using one AP and the number is incremented until we reached the maximum number of APs, which was determined according to the cabin's dimensions. The AP's transmission power was adjusted to minimize the transmission range, so the signal can travel a distance just enough to reach the seat beside the window in order to minimize the effect of its reflection. This allowed us to use a maximum number of 5 APs (Figure 5).

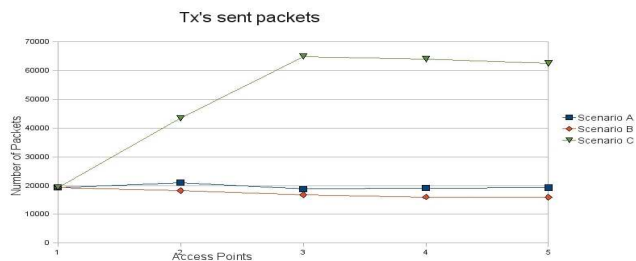

Figure 6. Packets sent by the transmitter

For all scenarios, the nodes (156 node + APs) were configured to have a large queue that can hold up to 1000 packets in order to prevent packet dropping. The transmission power was adjusted to 10mW as the minimum value defined in the 802.11 standard. In scenarios that use different channels, Channels 1, 6, and 11 were adjusted to their frequencies 2.412e9 Hz, 2.437e9 Hz, and 2.462e9 Hz respectively. The Rx threshold was determined according to the required transmission range. It was calculated by the tool "Threshold" provided as a separate program with the NS2 simulator. Table I shows the values used with each number of APs. For each simulation, the APs were distributed evenly

throughout the aisle to provide a full coverage for the cabin.

Number of APs	Transmission range (meters)	Rx threshold
1	10.5	8.97474e-9
2	5.25	3.58989e-8
3	3.5	8.07726e-8
4	2.625	1.43596e-7
5	2.1	2.24368e-7

Table I  
RX THRESHOLD VALUES

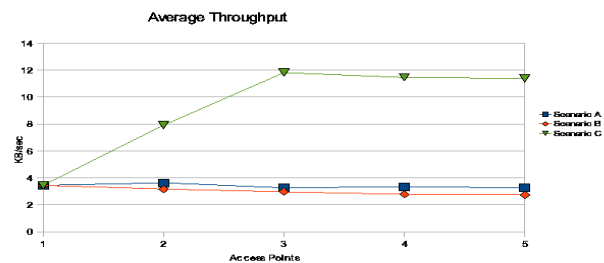

Figure 7. Average Throughput



Figure 8. Average Delay

When comparing the three scenarios we can find that using just different number of APs doesn't have a great impact on the networks performance, but when accompanied with channel separation the networks performance is dramatically enhanced. Figure 6, Figure 7, and Figure 8 combine the results of scenarios A, B, and C. It is noticeable that there is no great difference between scenario A and B; this is due to the existence of large number of nodes in a small area. In addition, there are many nodes in the shared zone between every two APs. In this zone, nodes are able to detect two APs, but they select just one of them. In other words, on the physical level signals are interfering, while on the logical level only one AP is seen. However, as the number of APs increase, the difference between scenario A and B starts to increase slightly; this is because the number of nodes in the shared zone becomes less, so the interference decreases. On



the contrary, when using channel separation (i.e., scenario C) performance was dramatically enhanced after using 3 APs

It is worthy to note that the number of nodes assigned to each AP affects its performance; the fewer nodes we use, the higher performance we get. When using 1, 2, 3, 4, and 5 APs, each AP will have 156, 78, 52, 39, and 32 nodes respectively. However, the difference in the number of assigned nodes with 3, 4, and 5 APs is small. This justifies the reason for saturation after using more than 3 APs; where APs almost handles the same amount of APs

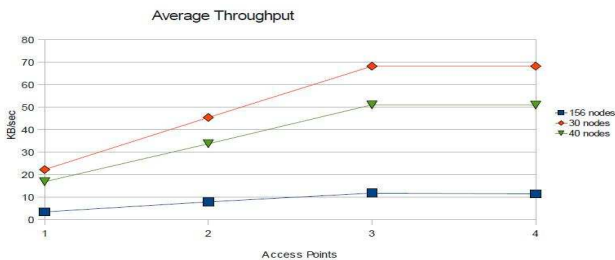

Figure 9. Average Throughput for different number of nodes

The results in Figure 7 showed that the best values introduced by scenario C is relatively small (i.e. 12 KB/sec); this is due to the high number of nodes within a small area causing interference between them. However, we have to highlight some issues. First, the APs are not used to convey video streaming; they are used to provide the passenger's PED with simple internet services, while video entertainment is achieved through the VDU dedicated for the IFE system. Second, we used the more reliable 802.11 version that supports 2 MB rate; this means that the passengers in the cabin can not be connected to the outside with a rate higher than that. Third, GPRS connections support a rate of 100 kb/sec, so that, if the performance degraded more than indicated in Figure 7 the PEDs can achieve internet services with the GPRS rate.

To study the effect of nodes' number we repeated scenario C with 30 and 40 nodes. Figure 9 shows that the network almost has the same behavior and the *Average Throughput* was greatly enhanced when the number of nodes decreased. This behavior shows the Airlines companies that they have two trade offs, either to provide a free internet service with poor performance, or to have a controlled access to keep acceptable performance. Consequently, a free internet access can be introduced in small flights since not all passengers are going to access the internet simultaneously, some of them will use other IFE services, or sleep, or talk. On the other hand, a prepaid internet access can be used in large flights where number of internet users will be considerably large.

3) *WUSB*: *WUSB* to connect passenger's devices seems to be an appealing solution since it doesn't require any additional adapters or connectors, and avoids interference

Elapsed time		Delay ratio
WUSB	915secs	((344/915)*100)-100=62.4%
Wired USB	344secs	

Table II  
WUSB VS WIRED USB

with other wireless technologies (i.e., WLAN, Bluetooth, etc.) by using different bandwidth.



Figure 10. WUSB test-bed

Figure 10 shows our WUSB experimentations test-bed. *WUSB Host* and *Device* dongles were used to connect USB devices. The *Host* dongle is connected to the computer USB port, while the *Device* dongle connects the USB devices. The dongles driver allows changing of transmission as well as the transmission channels.

- *Connecting different USB devices*: Connecting multiple USB devices (i.e., mouse, and keyboard) was done in two different ways; firstly by using two *Device* dongles for each USB device, secondly by using a USB hub. The results of the first approach were not satisfactory because the two dongles were using the same channel causing interference between them. However, the *Host* dongle has the ability to choose between seven different channels. In other words, it is possible to use seven *Hosts* at the same transmission range without any interference between them. The second approach gave better performance. Moreover, a hub is much more economical than using a *WUSB* dongle dedicated for each device.
- *File transfer*: It is important to know if *WUSB* is capable of transferring large files, and to what extent it is comparable to wired USB, so 4064 files of size 892MB were transferred to a flash USB storage device using *WUSB* and wired USB. The results shown in Table II indicate that *WUSB* are slower by almost 60% than wired USB.
- *Transmission range with different power levels*: The test started by putting the *Host* dongle and the *Device* dongle on the same line of sight; then the *Device* dongle is moved away until it is disconnected. The same procedure was repeated while using two *Device* dongles. The two dongles are placed at the same horizontal level with a separation of few centimeters, and are moved together. The whole experiment was repeated while changing the dongles transmission power level (i.e.,

low, normal and strong).

As shown in Table III, the existence of two dongles at the same area, and working at the same channel has a dramatic effect on transmission range, so when considering that the distances between seats inside the cabin is considerably short when compared with the minimum transmission range, then it is highly recommended to use different channels for neighboring dongles.

Transmission power	Max achieved distance in meters between Tx and Rx	
	Single device	Dual device
Low	7	4.2
Normal	12	6.3
Strong	16	8.4

Table III  
TRANSMISSION RANGE

4) *Smart Antennas*: Smart antennas can be used for node localization in WSN networks. Zhuhong [29] mentioned two methods for determining node's position, the range-based, and range-free methods. The first depends on the distance and angle information, while the later depends on estimating the location through the information of transmitted packets. According to this categorization, we will consider the range-based approach to provide our proposed protocol with the information necessary to allow each VDU to determine the position of its own PCU.

The smart antenna's location can be an issue for many arguments. One opinion is to fix the antenna in the seat's arm and to be directed towards the VDU, so the PCU will only act as a keyboard. Although this is an appealing solution, but it decreases the easiness of installation and reconfiguration of seats, and it may require physical changes to the seat arm's design. In addition, any changes in the position of the front seat's back, or the seat's arm itself (which can change its orientation in some types of seats) can affect the connection. For these reasons we propose to locate the antenna in the PCU itself. Our proposed protocol can provide a mechanism to determine the PCU's position; which can be determined by the proposed protocol as shown in the next sections.

#### IV. DESIGN OF THE PROPOSED PROTOCOL

For every VDU in the IFE system, there is a dedicated PCU to allow the passenger to choose his selections. Thus, each VDU is surrounded by different number of PCUs. Selecting the appropriate comrade is not an easy task especially if we considered that the PCUs are neither predefined nor pre-assigned for any VDU. Nevertheless, using non-configured PCUs makes the system more maintainable with respect to device failure where any failing device can be replaced instantaneously, and automatically recognized by the system. Accordingly, each VDU has to find its own PCU.

Device identification and device localization are usually treated in the literature as separate problems and are usu-

ally addressing outdoor situations. Radio frequency (RF) fingerprinting techniques [30]–[32] were used to identify wireless devices specially for security reasons. On the other hand, smart antennas are usually used for localization purposes [33], [34]. We did not find references of work done with the same assumptions, considering that our proposed protocol utilizes the localization capabilities of smart antennas to introduce a device identification technique.

The smart antenna technology can provide a significant help in such environment. First, it can overcome the drawbacks of some physical hindrances such as interference, and multipath fading. Second, it can provide the system with the location information between each transmitter and receiver in terms of distance and angle.

This information can be used in the coupling process between VDUs and PCUs; when a VDU is able to know the location information of the surrounding PCUs, it will be possible for it to select the required partner. However, such process needs a selection mechanism able to differentiate between the targeted and the unconcerned neighboring devices. Accordingly, the proposed protocol can use this information to allow the VDU to select its PCU without being confused by the large number of surrounding devices. The protocol is able to sense all the devices within range, identify the required device, and finally select it. Moreover, it is able to detect if the required device is out of service or not.

##### A. General requirements

Depending on the seats layout, each VDU is surrounded by one or more PCUs. When the system is started, these PCUs are not assigned to any VDU, so It is the task of each VDU to find its own PCU. The following problems may occur:

- A situation may exist where more than one PCU exist in the range of the same VDU. In this case, the protocol should be able to use the provided location information (i.e., angle and distance) to determine the suitable PCU.
- When the link between a VDU and its PCU is broken, the protocol must be able to detect the situation and determine if it is due to a PCU failure or because the user had moved it out of the VDU's range.
- When a failing unit is replaced (either a VDU or a PCU), it must be self configured to take its role in the network

Figure 11 shows a normal seat configuration where each VDU is fixed in its own seat and surrounded by different PCUs. The protocol has three phases, configuration phase, normal operation, and re-configuration phase.

- *Configuration Phase*: This phase occurs during the system's startup. It is responsible for determining the network's topology. Each VDU checks the availability of its PCU and responds with its status.
- *Normal Operation*: In this phase, the protocol must be aware of the availability of its assigned PCU.

- *Re-configuration phase:* It occurs when a VDU fails to connect to its PCU or vice versa. After the failing unit had been replaced or re-operated, it should be able to join the network automatically.

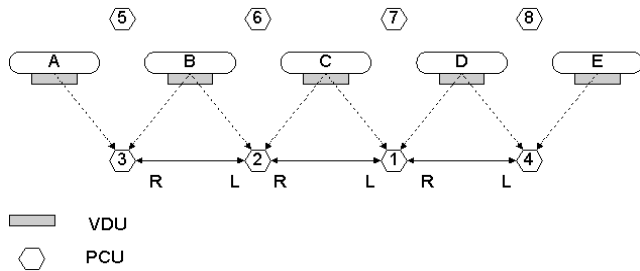

Figure 11. VDUs and PCUs distribution

### B. Specifications

The protocol should be able to allow each VDU to find its own PCU and provide their connection status. In other words, it is not the protocol's responsibility to transfer data between nodes. Transferring data like audio or video streams can be accomplished by other protocols (i.e., TCP/IP).

The protocol should provide the running applications with information required to take certain actions (i.e., warnings due to a failing PCU). The following is a list of the proposed services:

- *Multiple PCUs awareness:* The protocol should be able to detect multiple PCUs that may exist in the VDU's range and select the appropriate one.
- *ID assignment:* The protocol should automatically assign a unique ID to both of the PCU and the VDU so they can communicate with each other.
- *Failure reports:* A failing VDU or PCU should be detected and reported.
- *Self adaptation:* After replacing a failing device, it must be able to join the network automatically.
- *PCU out of range:* when a user moves or directs the PCU away of the VDU, the protocol should be able to identify this situation and differentiate between being out of range and out of service.

### C. Functionality and studied use cases

When the system is started, the *Configuration Phase* is initiated. In all scenarios, the VDU broadcasts a *QRY\_search* request and waits for replies within a predetermined time interval to prevent indefinite wait states. The next step is to use the angle information to exclude the PCU(s) behind it (since it is only interested in the PCUs at its front side) and starts to handle the other PCU(s) of valid replies (i.e., seat 'D' in Figure 12). All functioning PCUs, which are not assigned to another VDU will respond to the request. The correct PCU should be located at the nearest distance on the right side of the VDU, so the selection procedure looks

for the responding PCU, which has the least angle with the vertical "Y" axis, and the shortest distance. However, there may be a case where two PCUs are too close to each other to the extent that the VDU can't accurately determine the differences between their angle and distance. In this case the VDU asks them to start negotiation between each other. These situations are presented in Figure 12 and Figure 13 to present the following scenarios:

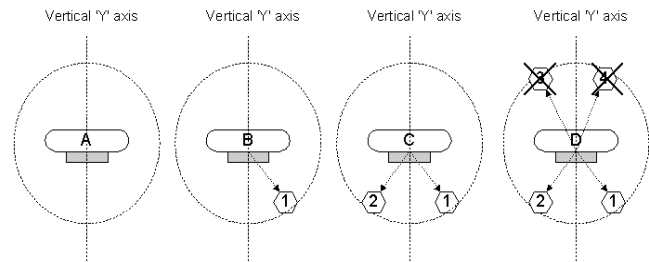

Figure 12. Different scenarios for less than three valid PCUs

- 1) *No PCU(s):* When The VDU doesn't receive a reply for its search request, it raises an error to indicate that no PCU(s) are within its range, and enters a search state until a PCU is found. (i.e., seat 'A').
- 2) *Best case:* only one valid PCU is located in its correct position within the VDU's range: The VDU sends a *QRY\_join* request and the PCU replies with a *QRY\_accept* to confirm the assignment (i.e., seat 'B').
- 3) *Two PCUs:* If the VDU received 2 valid replies within the time limit, then this indicates the presence of two PCUs within the range (i.e., seat 'C'). The PCU with the smallest angle with respect to the 'Y' axis is selected. If two PCUs are too close for the system to differentiate the difference in angle, then the PCU with the shortest distance is selected. If the difference in distance can't be determined, then the VDU sends a *QRY\_negotiate* request to authorize the PCUs to elect one of them. The negotiation result is returned to the VDU to know its elected PCU.
- 4) *The worst case is the existence of more than two PCUs:* If the VDU received more than two valid replies, then it starts to sort them in ascending order firstly according to their angle to the 'Y' axis, secondly according to their distance. It is expected that the required PCU has the smallest angle and the shortest distance on the right of the 'Y' axis. There are different scenarios for this situation (see Figure 13). Table IV shows how each situation can be handled.
  - Seat 'E': PCU1 was selected because it has the smallest angle on the right side of the 'Y' axis.
  - Seat 'F': PCUs 1&4 are firstly selected since they are at the right side. However, they have equal angles, so their distance is checked.. Finally, PCU1 is selected because it has a shorter distance.

Seat	Situation	Selection criteria		
		Angle	Distance	Negotiation
E	Small angle	1	-	-
F	Same angle	1&4	1	-
G	Too close(same angle & distance)	1&2	1&2	1

Table IV  
SELECTION CRITERIA

- Seat 'G': PCUs 1&2 were selected according to the angle and distance criteria. They are too close to each other to the extent that the VDU can't differentiate between their angles and distances, so the VDU initiates a negotiation session to elect one of them. Finally, PCU1 is selected.

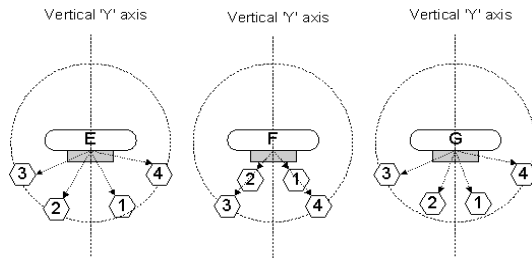

Figure 13. More than two PCUs within range

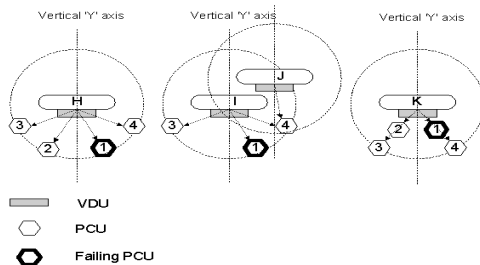

Figure 14. Failing PCUs scenarios

In fact, the real world is not that simple. If faults exist, then there will be exceptions in the above scenarios. For example, if the correct PCU was not functioning, then a wrong PCU can be chosen. This means that a PCU failure may affect its VDU as well as its neighboring VDU(s). To overcome this situation, the angle of the 1st PCU in the left quarter is always considered (i.e., PCU2). For instance, at seat 'H' (see Figure 14), if the angle of the recommended PCU for selection (i.e., PCU4) is greater than the angle of PCU2, this indicates that PCU1 is not working. This is due to the fact that the correct PCU must have the smallest angle and shortest distance to its VDU.

Unfortunately, this scheme doesn't solve the problem of seat 'I' where the angles and distances of PCU3 and PCU4

are equal, so they will enter a negotiation phase that ends up with electing PCU4 (which is not correct). Therefore, it is mandatory for PCUs to wait before starting negotiation to allow the wrong PCU (i.e., PCU4) to be chosen by its appropriate VDU (i.e., seat 'J'). In this case, seat 'I' can raise an error for not finding its PCU.

For seat 'K', PCU4 angle is equal to PCU2 angle, but with a greater distance, so PCU4 is not the correct PCU. In addition, each VDU has to inform all the PCUs in its range that it had found its PCU. On the other hand, a PCU, which knows that all the surrounding VDUs had found their own PCU will understand that its VDU is not functioning.

D. Selection mechanism

Each VDU creates a list of the surrounding PCUs containing their location information. At the start of the selection procedure, the VDU deletes from its PCUs list all the PCUs instances behind it, and then two lists are created, one for PCU(s) on the left hand side, and the other for PCU(s) on the right hand side. The two lists are sorted in an ascending order according to their angles. After sorting, the two lists can be categorized as shown in Table V. The table shows the actions that should be taken according to each state; remember that selection is taken according to angle, distance, and negotiation, respectively.

State	Number of PCUs		Action
	Left zone	Right zone	
1	$\geq 0$	0	Raise an error
2	0	1	Wait then select the PCU
3	0	$> 1$	Select (according to angle, and distance, or negotiation)
4	$\geq 1$	$\geq 1$	Compare $\rightarrow$ Wait $\rightarrow$ Select

Table V  
DOMAIN OF PCUS OCCURENCIES

- *Angle selection:* For state1, an error is initiated when there are no PCUs in the right zone. For state2, if only one PCU is present in the right zone then it will be selected after waiting for a time interval. The waiting time is important in case that the correct PCU is not functioning where another PCU may be selected. The waiting time gives the other PCU(s) the chance to be selected by its own VDU(s). This will lead to raising an error after the malfunctioning PCU is not detected. For state3, the selection between PCUs in the right zone is performed according to their angle and distance, or finally by negotiation. For state4 where there is at least 1 PCU in each zone, the selection is performed according to their angles where  $\theta_1$  and  $\theta_2$  represent the angles of PCUs in the right and left zones, respectively. The angle of the first PCU in both zones (with respect to the Y axis) is compared and actions are taken according to Table VI. Note that the absolute value of angles is used in the comparison.

Condition	Action
$\theta_1 < \theta_2$	$\theta_1$ is selected if no other PCU in the right zone has the same angle, other wise a distance selection is performed
$\theta_1 > \theta_2$	Error is raised
$\theta_1 = \theta_2$	Selection according to distance is performed

Table VI  
ANGLE SELECTION CRITERIA

Seat	Differences in		Action
	r	$\theta$	
L	-ve	Zero	PCU 1 is selected
M	-ve	-ve	PCU 2 is selected
N	Zero	-ve	PCU 1 is selected
P	+ve	Zero	Error is Raised

Table VII  
NEGOTIATION ACTIONS

- *Distance selection:* When two or more of the selected PCUs at the right side have the same angle, the PCU with the shortest distance "r" is selected. If two PCUs have the same shortest distance, then a negotiation is started to elect one of them and inform the VDU with the result.

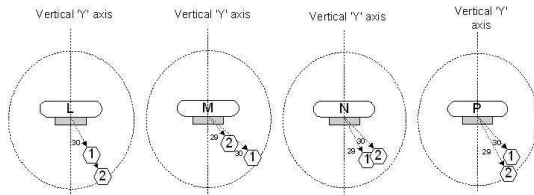

Figure 15. Negotiation cases

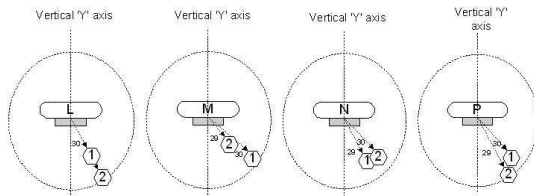

Figure 16. Negotiation cases

- *Negotiation selection:* The negotiation session is shared between the VDU, which initiates the request, and the PCUs that participate in the negotiation. Firstly, the VDU creates a *Participation List* for all of the concerned PCUs, it then sends a negotiation message that includes the list to each of the participants, and waits for their reply. Each PCU receives the message and tries to find its position with respect to the others. Each PCU is already aware of the VDU's position. Figure 16 shows different cases of negotiation and Table VII shows the related actions. For seat "L" PCUs 1&2 are able to communicate with each other and to

decide that PCU1 is nearer to the VDU. The same thing happens to seats "M & N". For seat "P", they will notice that PCU2 is the nearest but with larger distance; this may be due to a failing PCU, so an error is raised.

## V. PROTOCOL DESIGN AND EVALUATION

Fixing bugs in a protocol is an important and often the highest priority activity. Tracking down bugs, in non predefined protocol specifications, is a challenge to many designers. Checking protocol correctness is often done using verification techniques such as "Reachability Analysis" [35], which searches through all reachable states. It is almost impossible to do an exhaustive test, which often requires 100% of the reachable states. Another approach can be used, which is program proof. This requires an automated solution for analyzing and testing the design, so we used TAU version 3.1 [36] to build and verify our UML model. UML language is a formal language ensuring precision, consistency, and clarity in the design that is crucial for mission critical applications. It has a high degree of testability as a result of its formalization for parallelism, interfaces, communication, and time. After identifying the protocol's functionality, NS2 simulator was used to apply more scenarios and show the protocol's performance.

### A. The UML model

The informal techniques used to design communication protocols (i.e., timing diagrams) yield a disturbing number of errors or unexpected and undesirable behavior in most protocols, so we are interested in formal techniques, which are being developed to facilitate design of correct protocols. It is accepted that the key to successfully develop a system is to produce a good system specification and design. This task requires a suitable specification language, satisfying the following needs:

- A well designed set of concepts.
- Unambiguous, clear, and precise specifications.
- A thorough and accurate basis for analyzing the specifications.
- A basis for determining whether or not an implementation conforms to the specifications.
- Computer support for generating applications without the need for the traditional coding phase.

UML language has been defined to meet these demands.

Three different layers were modeled, *Upper*, *Protocol*, and *Lower* layers. The *Upper* layer initiates the session by a request to start the search phase and waits for the results; while the *Lower* layer provides the protocol layer with the distance "r" and the angle " $\theta$ ". The *Protocol* layer provides the necessary functionality that our protocol needs to work correctly. In addition, a model was used to represent the environment and determines the number of PCUs and their locations with respect to the VDU.

1) *The model's structure:* The protocol's model consists of three main classes; *VDU* and *PCU* classes - to represent the behavior of the VDU, the PCU - and the *Network* class, which determines the scenario parameters. Each scenario consists of a VDU, and a set of PCUs of different locations. The *Network* class is responsible for informing the working instances of the VDU and PCU(s) with their locations.

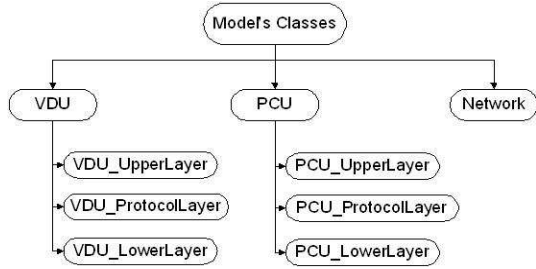

Figure 17. Model structure

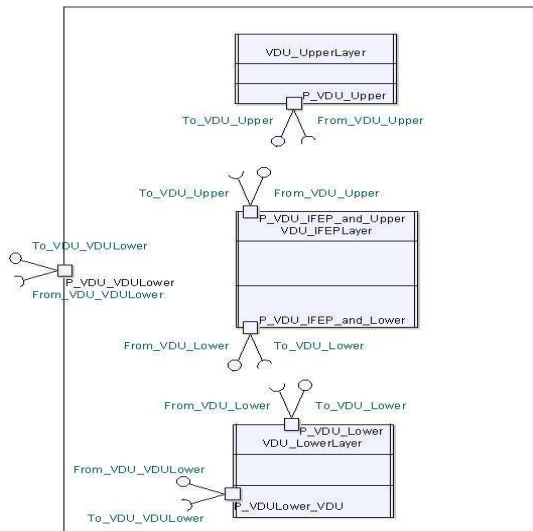

Figure 18. VDU Class

Both of the *VDU* and *PCU* classes consist of three internal classes, the *Upper Layer* class, the *Protocol Layer* class, and the *Lower Layer* class (see Figure 17). The *Protocol Layer* class represents the core of the protocol, while the other two layers are just assistances to provide the needed services. The connection between these layers and the surrounding environment takes place through the main class (i.e., *VDU* class, *PCU* class). Figure 18 represents the *VDU* class as an example of the UML structures. Each internal class has input and output interfaces to communicate to each other. The lower layer class has interfaces to the containing *VDU* class to allow it to communicate with external entities.

For example, to start a search request, the request is sent from the *Upper Layer* to the *Protocol Layer* where the correct decision is taken and the required action is determined.

Now, the action should be sent to a corresponding instance (i.e., *PCU*). A signal is sent to the *Lower Layer* then to the containing class, which in turn sends the signal to the corresponding instance. When the corresponding instance receives the signal, the signal reaches the *Protocol Layer* of the instance through the same reversal internal path.

On the other hand, the *Network* class has a different structure since it is not concerned with the protocol's behavior. It determines the *VDU* and *PCU* instances, and provides the working instances with their location information in order to simulate the services provided by the smart antennas

2) *The model's behavior:* An example for the model behavior is shown in Figure 19. As an initial preparation, the *Network* class sends the location information to the *VDU* and *PCU*(s) instances so that each instance knows its own location (signal 1). After the *VDU* had received its initialization data, its *Upper Layer* sends a search request to its protocol layer (signal 2). The *Protocol Layer* broadcasts this request to the neighboring *PCU*(s). When the *Protocol Layer* of a *PCU* instance receives the request, it replies with a signal that shows its presence (signal 3).

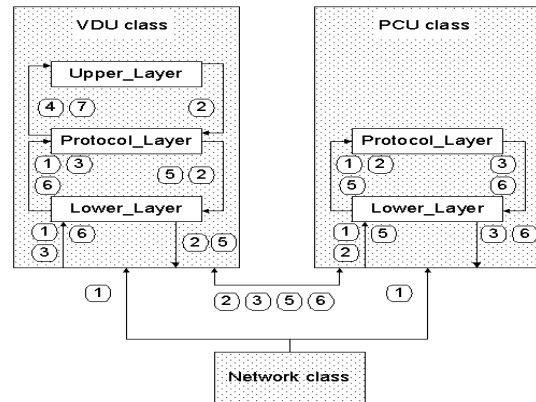

Figure 19. Model's signals

The *VDU* waits until it receives the replies to count the number of available *PCU*s. If no *PCU* had replied, then an error message is sent to the upper layer (signal 4). If one or more *PCU* had replied, then a selection procedure starts. The result of this selection is used to send a "Join" signal to the selected *PCU* (signal 5) and waits for its "Reply" signal to confirm its joining (signal 6). The confirmation is sent to the upper layer to inform it with the *PCU* that belongs to the *PCU* (signal 7).

*B. performance evaluation*

Obviously, TAU can provide us with a way to verify the correctness of the protocol through limited scenarios. It is difficult to use it to experiment with complicated scenarios, and determine performance issues. NS2 simulator [27] was used as the next step. It is a part of VINT (Virtual Internet Testbed) project [37]. It is an open source simulator that

can be used to evaluate different issues for both wired and wireless networks. In the simulation part we are trying to verify the written code for the NS2 as well as to find out the protocol's points of weakness.

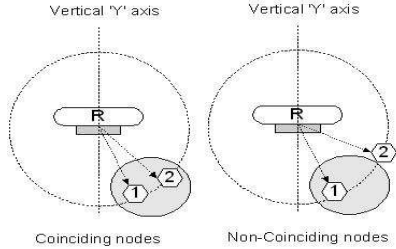

Figure 20. Threshold area

A problem that faced us was the unavailability of a smart antenna module embedded in NS2 because the protocol's behavior is highly dependent on their presence. However, this was not a great issue because NS2 keeps track of the location of each node in the simulation through the class *MobileNode*. This means that the results of the simulation represents the actual performance of the protocol's behavior.

The NS2 simulation is defined by TCL scripts, and C++ codes where the protocol's module was implemented in C++ and linked to the TCL script for further configuration. For example, if we used the provided coordinates we will never be able to start a negotiation session, because the VDU will always see that the PCUs are of different angles and distances. In other words, to implement negotiation scenarios, the VDU must consider the PCUs as if they are coinciding. This was solved by using a *Threshold* variable (changed through the TCL script) through which two PCUs are coinciding if the distance between them is less than the *Threshold* value. The Threshold area is represented by dark circle in Figure 20, which represents two coinciding nodes, when they are located within a circle of radius equal to the *Threshold* value, and are considered non-coinciding if the distance between them is greater than the *Threshold*.

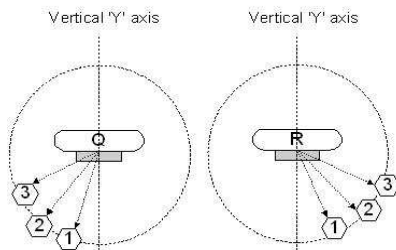

Figure 21. NS2 extra scenarios

In addition to the scenarios mentioned before (i.e., seats "A" to "P"), we implemented two extra scenarios (see Figure 21) Seat "Q" represents an error situation (because

there isn't any PCUs in the right area). Seat "R" represents a normal operation. They are almost like the situations of seat "A" and "B" respectively, but we used them just to prove that the existence of multiple PCUs within the same region doesn't affect the correctness of the selection

Source	Message	Meaning
VDU	Search_Request	Starts the search phase
	Search_Join	Accepts its own PCU
	Negotiate	Starts a negotiation session
PCU	Search_Reply	A respond to Search_Request
	Search_Accept	A respond to Search_Join
	Negotiate_Request	Starts negotiation between PCUs
	Negotiate_Accept	Confirms acceptance of Negotiate_Request
	Negotiate_Reply	A respond to Negotiate

Table VIII  
MESSAGES LIST

Table VIII summarizes the types of messages exchanged between VDUs and PCUs instances. They are categorized according to the initiating device. The message sequence depends on the type of situation if it is a normal operation (Figure 22) or an error situation (Figure 23) or a negotiation operation (Figure 24).

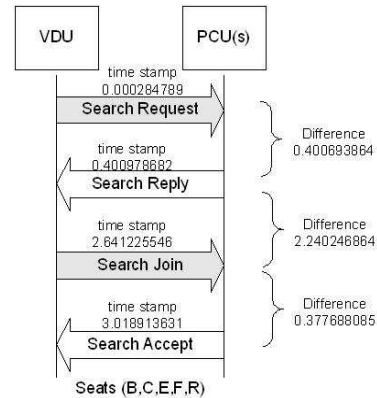

Figure 22. Normal operation

Figure 22, Figure 23, and Figure 24 show timing diagrams for three categories of scenarios, normal operation, error operation, and negotiation operation respectively. Each message is labeled by its transmission time stamp. When it happens that the same type of message is sent from different transmitters we choose the time stamp of the latest one (maximum value). For example, when the VDU broadcasts a *Search\_Request* message, it receives a *Search\_Reply* message from all the neighboring PCUs. In this case we choose the time stamp of the last received *Search\_Reply*. At the right side of the figures, we calculated the time delay between each two successive messages. At the bottom of the figures we indicated the scenarios (i.e., seats), which match each operation.

Figure 22 shows the results of normal operation scenarios where the VDU broadcasts the request and the PCU(s) send(s) their replies. The VDU decides, which PCU is the required one and sends a join request for the chosen one, which in turn replies with its acceptance. It is obvious that the maximum delay in this operation is the wait period, which the VDU uses to wait for all available PCUs to respond. The delay was set to approximately 2secs. The value was chosen to be relatively large to show its impact on the protocol's performance; considering that the processing time of the requests is trivial when compared to the wait time.

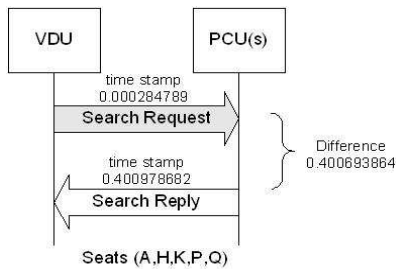

Figure 23. Error operation

Figure 23 shows the fastest operation, which took place when the required PCU is not detected. After waiting for the delay period (i.e., 2secs) through which it receives all the *Search\_Reply* messages (if any). The VDU raises an internal error to show the failure of finding the PCU.

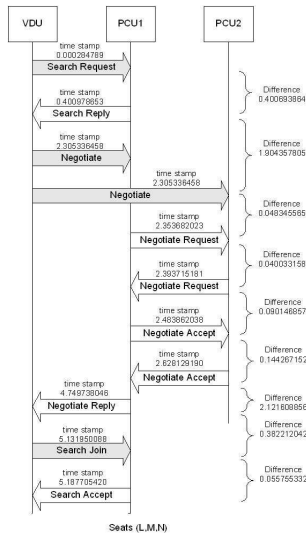

Figure 24. Negotiation operation

Figure 24 shows the most time consuming operation, which takes place during negotiation between PCUs to elect one of them. The first part is the same as the start of a normal operation, but when the VDU fails to distinguish the location difference between two PCUs where one of them is

probably the required one, it asks them to start negotiation and elect one of them. The most time consuming parts are the waiting periods (mentioned above), and the negotiation process between the PCUs. Each of them is about 2 s.

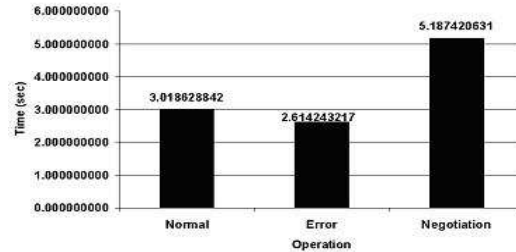

Figure 25. Convergence time

Figure 25 shows a comparison for the convergence time of each operation. It indicates that the negotiation operation is the slowest one, while the difference between a normal operation and an exception (error) is not large. However, the delay of the slowest case is still acceptable during the system's startup. On the other hand, no significant comparison can be made to previous work since the wireless cabin environment is still under investigation.

VI. CONCLUSION AND FUTURE WORK

Heterogeneous network architecture is a promising solution for such application. Using PLC networks can be a competitive solution since it decreases the amount of cabling inside the cabin, and can be used to connect the APs (to support mobility) directly to the network system. Moreover, it overcomes the interference constrain, and can provide enough bandwidth to support heavy traffic required for multimedia services. When combined with WUSB, it becomes easier for passengers to connect their PEDs.

Through experimentation results and simulations, this work proves that it is possible to build a heterogeneous network, which contains all the mentioned technology; each to solve a certain part of the problem. Multimedia content distribution supported by PLC and Ethernet architecture added to personal communication supported by WUSB and WiFi can provide the IFE system with a satisfactory solution needed for such systems. This can be done without interfering with each other.

Smart antennas can solve or minimize interference problems. However, new wireless technologies like smart antennas require special mechanisms to fully utilize their capabilities. The proposed protocol is designed to use these capabilities to provide the IFE remote control with self-configurable wireless characteristics. Although the protocol's procedures seems complicated, but in fact they are not because it depends on comparing existing information without using excessive messaging. This behavior enhances the convergence time and the protocol's performance.



The UML model and the NS2 simulation proved that the proposed protocol is able to utilize the location information provided by the smart antennas to allow each VDU to detect its own PCU. Moreover, the protocol considered the probable failure situations, and was able to detect and handle them. However, the protocol point of weakness is its internal timer. The simulation results showed that the value of the timer has a great impact on convergence time.

In addition, the usage of an UML model before creating a NS2 simulation had proved to be of great importance to the protocol's design life time. Although designing the UML model seemed to be a time consuming part, but it saved the effort of bug tracking and semantic errors during implementing the NS2 module.

In this phase of the work, we aimed to have a proof of the concept to show the feasibility of our proposed protocol. The next step is to enhance the written code by using better data structures to minimize the processing delay and improve the convergence time. In addition, we are aiming at trying simulations that represent a real cabin configuration, and inject scenarios with randomly failing devices. Furthermore, we are looking forward to implement a real test-bed to experiment the performance of our protocol in a real environment.

#### REFERENCES

- [1] Akl A., Gayraud T., and Berthou P., "Investigating Several Wireless Technologies to Build a Heterogeneous Network for the In-Flight Entertainment System Inside an Aircraft Cabin", The Sixth International Conference on Wireless and Mobile Communications (ICWMC), pp 532-537, 2010.
- [2] Niebla C.P., "Coverage and capacity planning for aircraft in-cabin wireless heterogeneous networks", IEEE Vehicular Technology Conference, pp 1658-1662, 2003.
- [3] Jahn A. and Holzbock M., "Evolution of aeronautical communications for personal and multimedia services", IEEE Communications Magazine, vol 41, pp 36-43, 2003.
- [4] Thales IFE site: <http://www.thales-ifs.com/>, last visited: 13 July 2011.
- [5] AeroMobile site: <http://www.aeromobile.net/>, last visited: 13 July 2011.
- [6] FlyNet site: <http://konzern.lufthansa.com/en/themen/net.html>, last visited: 13 July 2011.
- [7] Folden D., Jackson T., Panique M., Tiensvold R., Wolff R.S., Howard T., Julian E., Junkert L., Lopez D., and Oudshoorn M.J., "An Aircraft Cabin Wireless System for Games and Video Entertainment", ACM Computer in Entertainment, pp 1-17, 2007.
- [8] Liu H., "In-Flight Entertainment System: State of the Art and Research Directions", Second International Workshop on Semantic Media Adaptation and Personalization (SMAP 2007), pp 241-244, 2007.
- [9] Alamdari F., "Airline in-flight entertainment: the passengers' perspective", Journal of Air Transport Management, vol 5, pp 203-209, 1999.
- [10] Hrasnica H., Haidine A., and Lehnert R., "Broadband Powerline Communications Networks", John Wiley & Sons Ltd., 2004.
- [11] Mcauley A. J. and Manousakis K., "SELF-CONFIGURING NETWORKS", 21st Century Military Communications Conference Proceedings, vol 1, pp 315-319, 2000.
- [12] Castagne S., Curran R., and Collopy P., "Implementation of value-driven optimisation for the design of aircraft fuselage panels", Proceedings of International Journal of Production Economics, pp 381-388, 2009.
- [13] Hurley W.C. and Cooke T.L., "Bend-insensitive Multimode Fibers Enable Advances Cable Performance", Proceedings of the 58th International Wire and Cable Symposium (IWCS), pp 458-467, 2009.
- [14] Holzbock M., Hu Y., Jahn A., and Werner M., "Advances of aeronautical communications in the EU framework", International Journal of Satellite Communications and Networking, vol 22, pp 113-137, 2004.
- [15] Diaz N.R. and Esquitino J.E.J., "Wideband Channel Characterization for Wireless Communications inside a short haul aircraft", Vehicular Technology Conference, pp 223-238, 2004.
- [16] Youssef M., Vahala L., and Beggs J.H., "Wireless network simulation in aircraft cabins", IEEE Antennas and Propagation Society Symposium, vol 3, pp 2223-2226, 2004.
- [17] Moraitis N., Constantinou P., Fernando Perez F., and Valtr P., "Propagation Measurements and Comparison with EM Techniques for In-Cabin Wireless Networks", Journal EURASIP Journal on Wireless Communications and Networking - Special issue on advances in propagation modelling for wireless systems, pp 1-13, 2009.
- [18] Chiu S. and Michelson D.G., "Effect of Human Presence on UWB Radiowave Propagation Within the Passenger Cabin of a Midsize Airliner", IEEE Transactions on Antennas and Propagation, vol 58, pp 917-926, 2010.
- [19] Thompson H., "Wireless and Internet communications technologies for monitoring and control", Control Engineering Practice, vol 12, pp 781-791, 2004.
- [20] Lansford J., Stephens A., and Nevo R., "Wi-Fi (802.11b) and Bluetooth: Enabling Coexistence", IEEE Communications Magazine, pp 20-27, 2001.
- [21] Leavitt N., "For Wireless USB, the Future Starts Now", IEEE Computer Society, vol 40, pp 14-16, 2007.
- [22] Udar N., Kant K., Viswanathan R., and Cheung D., "Characterization of Ultra Wide Band Communications in Data Center Environments", Proceedings of ICUWB, pp 322-328, 2007.
- [23] Sohn J.M., Baek S.H., and Huh J.D., "Design issues towards a high performance wireless USB device", IEEE International Conference on Ultra-Wideband, vol 3, pp 109-112, 2008.

- [24] Winters Jack H., "*Smart Antenna Techniques and Their Application to Wireless Ad-hoc Networks*", IEEE Wireless Communications Journal, pp 77-83, 2006.
- [25] Okamoto Garret T., "*Smart antenna systems and wireless LANs*", Kluwer Academic Publishers, pp 225, 2002.
- [26] MGEN site: <http://pf.itd.nrl.navy.mil/mgen/mgen.html>, last visited: 13 July 2011.
- [27] NS2 site: <http://www.isi.edu/nsnam/ns/>, last visited: 13 July 2011.
- [28] Kaouris A., Zaras M., Revithi M., Moraitis N., and Constantinou P., "*Propagation Measurements inside a B737 Aircraft for In-Cabin Wireless Networks*", IEEE Vehicular Technology Conference (2008), pp 2932-2936, 2008.
- [29] You Z., Meng Max Q.H., Liang H., Li S., Li Y., Chen W., Zhou Y., Miao S., Jiang K., and Guo Q., "*A Localization Algorithm in Wireless Sensor Networks Using a Mobile Beacon Node*", Proceedings of the International Conference on Information Acquisition, pp 420-426, 2007.
- [30] Scanlon P., Kennedy I., and Liu Y., "*Feature Extraction Approaches to RF Fingerprinting for Device Identification in Femtocells*", Bell Labs Technical Journal, vol 15, pp 141-151, 2010.
- [31] Aldasouqi I. and Salameh W., "*Detecting and Localizing Wireless Network Attacks Techniques*", International Journal of Computer Science and Security (IJCSS), vol 4, pp 82-97, 2010.
- [32] Danev B. and Capkun S., "*Transient-based Identification of Wireless Sensor Nodes*", Proceedings of the International Conference on Information Processing in Sensor Networks, pp 25-36, 2009.
- [33] Zhang B. and Yu F., "*LSWD : Localization Scheme for Wireless Sensor Networks using Directional Antenna*", IEEE Transactions on Consumer Electronics, pp 2208-2216, 2010.
- [34] Seshan Srirangarajan S.F.A.S. and Tewfik A.H., "*Implementation of a Directional Beacon-Based Position Location Algorithm in a Signal Processing Framework*", IEEE Transaction On Wireless Communication, vol 9, pp 1044-1053, 2010.
- [35] Lin F.J., Chu P.M., and Liu M.T., "*Protocol Verification using reachability analysis*", ACM Computer Communication Review, pp 126-135, 1988.
- [36] IBM Rational Tau site : <http://www-01.ibm.com/software/awdtools/tau/>, last visited: 13 July 2011.
- [37] VINT project site: <http://www.isi.edu/nsnam/vint/>, last visited: 13 July 2011.