



HAL
open science

Joint Space-Time Coded Modulation and Channel Coding for Iterative Non-Coherent MIMO Schemes

Ali El Arab, Jean-Claude Carlach, Maryline H elard

► **To cite this version:**

Ali El Arab, Jean-Claude Carlach, Maryline H elard. Joint Space-Time Coded Modulation and Channel Coding for Iterative Non-Coherent MIMO Schemes. IEEE WPMC 2011, Oct 2011, Brest, France. hal-00659230

HAL Id: hal-00659230

<https://hal.science/hal-00659230>

Submitted on 12 Jan 2012

HAL is a multi-disciplinary open access archive for the deposit and dissemination of scientific research documents, whether they are published or not. The documents may come from teaching and research institutions in France or abroad, or from public or private research centers.

L'archive ouverte pluridisciplinaire **HAL**, est destin ee au d ep ot et  a la diffusion de documents scientifiques de niveau recherche, publi es ou non,  emanant des  tablissements d'enseignement et de recherche franais ou  trangers, des laboratoires publics ou priv es.

Joint Space-Time Coded Modulation and Channel Coding for Iterative Non-Coherent MIMO Schemes

Ali El Arab

France Telecom-Orange Labs,
4 rue du Clos Courtel,
35512 Cesson-Sévigné Cedex, France
ali.elarab@orange-ftgroup.com

Jean-Claude Carlach

France Telecom-Orange Labs,
4 rue du Clos Courtel,
35512 Cesson-Sévigné Cedex, France
jeanclaude.carlach@orange-ftgroup.com

Maryline Hélar

INSA-Rennes/Rennes-I University
20 avenue des Buttes Des Coesmes,
35000 Rennes, France
maryline.helard@insa-rennes.fr

Abstract—A new joint channel-coding, modulation and space-time coding scheme is proposed as a new multi-antenna Multi-Input Multi-Output (MIMO) scheme called “Matrix Coded Modulation” or “MCM”. The existing non-coherent schemes such as the Differential Space-Time Modulation (DSTM) leads to performance degradation compared to coherent systems in which perfect channel state information (CSI) is assumed. Decoding in the MCM schemes is performed iteratively, based on specified detection criteria. This new scheme is also adapted for coherent and non-coherent systems. The polynomial distribution of the Euclidean distance based on the detection criteria depends on the Hamming minimal distance of the channel-error correcting code employed in the MCM scheme.

Keywords: MIMO systems, coherent, non-coherent, differential space-time coding, channel coding, coded modulation, Euclidean distance.

I. INTRODUCTION

Several techniques of data transmission over wireless MIMO communication systems exist. In most practical systems, it has been assumed that perfect channel estimates (CSI) are available at the receiver and coherent detection is employed. In this case, pilot symbols are sent to estimate the channel accurately. However, in some situations, it may be costly or difficult to estimate this channel, especially in a high-mobility environment. When CSI is not available at either the transmitter or the receiver, non-coherent detection is employed. In Single-Input Single-Output (SISO) systems, Differential Phase Shift Keying (DPSK) can be applied. This technique was extended to be suitable for non-coherent MIMO schemes especially for Space-Time Block Codes (STBC) [7] [9] or Space-Frequency Block Codes (SFBC) [18]. Non-coherent detection was firstly proposed by Hochwald and Marzetta in [13] [10] and uses unitary-space-time block codes. More recently Hughes [12] has proposed differential transmit diversity schemes for multiple antenna systems. For instance, space-time differential modulation is used in the standard IEEE IS-54 [4].

In some cases, differential schemes induce a loss of about 3dB compared to the coherent techniques [16] [17] [9]. The main goal of this paper is to compare the new non-coherent MCM scheme with existing differential scheme in order to partially or totally recover this loss regarding to coherent schemes. We propose the 2×2 Alamouti differential scheme presented in [11] concatenated with channel-error correcting code. In this

scheme, matrix \mathbf{S}_T is transmitted during 2 symbol-durations T_s and is related to the previously transmitted matrix \mathbf{S}_{T-1} by the relation $\mathbf{S}_T = \mathbf{S}_{T-1}\mathbf{V}_T$. \mathbf{V}_T are unitary matrices verifying $\mathbf{V}\mathbf{V}^H = \mathbf{V}^H\mathbf{V} = \mathbf{I}_2$, H is the hermitian operator “transpose and conjugate” and \mathbf{I}_2 the 2×2 identity matrix. Many differential detectors exist e.g. the Conventional Detector (CD) and the Decision Feedback Differential Detection (DFDD) [17]. The CD consists of finding the estimated information matrix $\hat{\mathbf{V}}_T$ based on the received matrices \mathbf{Y}_T and \mathbf{Y}_{T-1} such as: $\hat{\mathbf{V}}_T = \underset{(\hat{\mathbf{V}}_T)}{\text{Arg max}} \mathcal{R} \{ \text{Tr}[\tilde{\mathbf{V}}_T^H (\mathbf{Y}_{T-1})^H \mathbf{Y}_T] \}$. However, in all

the differential schemes, the fading is assumed to be constant or quasi-static over a frame of L transmitted bits and vary independently from one frame to another.

Based on a novel concept merging the error-correcting code and the modulation in one function, we introduce in this paper, a new MIMO coding scheme for any number of transmit and receive antennas compatible with a coherent or a non-coherent context. The outline of this paper is as follows: In section II, we present the new MCM scheme in general form. In section III, we introduce our 2×2 Matrix Coded Modulation (MCM) scheme by presenting it with with the Hamming convolutional code obtained by unwrapping the tail-biting trellis of the Hamming $H(n=8, k=4, d_{min}=4)$ block code. In section IV, we extend our MCM scheme with the systematic Golay convolutional code obtained by unwrapping the tail-biting trellis of the Golay $G(n=24, k=12, d_{min}=8)$ block code. For each model, we compute the polynomial distribution of the euclidian distance based on the appropriate detection criteria. In section V, we present some results of simulations. Finally, conclusions and perspectives are summarized in section VI.

II. MATRIX CODED MODULATION SYSTEM MODEL WITH CHANNEL ERROR-CORRECTING CODE

In this paper we present a new MIMO scheme called “Matrix Coded Modulation or MCM” which consist of merging channel-coding, modulation and space-time coding into one function. Although we consider systems with $N_t = 2$ transmit antennas and $N_r = 2$ receive antennas, we can generalize these MCM schemes for any other $N_t \times N_r$ system. In Fig.1, we show a general model of the MCM scheme. The encoded bits are mapped directly into invertible $N_t \times T$ matrices without

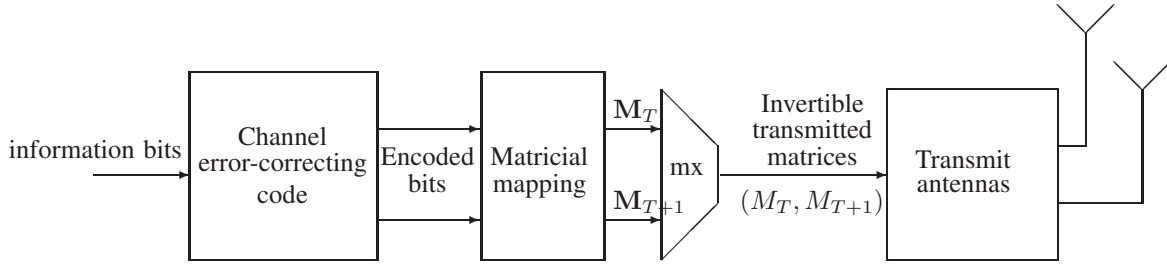

Fig. 1. MIMO-MCM_{2×2} system model

using the ordinary *PSK* modulation. The matrices of the Weyl group \mathcal{G}_w are considered in this paper [3]. The Weyl group \mathcal{G}_w [3] is very simply generated as a set of 12 cosets ($\mathcal{C}_0, \mathcal{C}_1, \dots, \mathcal{C}_{11}$) each containing 16 invertible matrices. The first coset \mathcal{C}_0 is defined as:

$$\mathcal{C}_0 = \left\{ \alpha \begin{bmatrix} 1 & 0 \\ 0 & \pm 1 \end{bmatrix}, \alpha \begin{bmatrix} 0 & 1 \\ \pm 1 & 0 \end{bmatrix} \right\}$$

with $\alpha \in \{+1, -1, +i, -i\}$. The 12 cosets of \mathcal{G}_w are derived from \mathcal{C}_0 as follows:

$$\mathcal{C}_k = \mathbf{a}_k \cdot \mathcal{C}_0 \quad \forall k = 0, 1, \dots, 11$$

where the matrices $\mathbf{a}_0, \mathbf{a}_1, \dots, \mathbf{a}_5$ are respectively:

$$\mathbf{a}_0 = \begin{bmatrix} 1 & 0 \\ 0 & 1 \end{bmatrix}, \mathbf{a}_1 = \begin{bmatrix} 1 & 0 \\ 0 & i \end{bmatrix}, \mathbf{a}_2 = \frac{1}{\sqrt{2}} \begin{bmatrix} 1 & 1 \\ 1 & -1 \end{bmatrix},$$

$$\mathbf{a}_3 = \frac{1}{\sqrt{2}} \begin{bmatrix} 1 & 1 \\ i & -i \end{bmatrix}, \mathbf{a}_4 = \frac{1}{\sqrt{2}} \begin{bmatrix} 1 & i \\ 1 & -i \end{bmatrix}, \mathbf{a}_5 = \frac{1}{\sqrt{2}} \begin{bmatrix} 1 & i \\ i & i \end{bmatrix}.$$

and the matrices $\mathbf{a}_6, \mathbf{a}_7, \dots, \mathbf{a}_{11}$ are given by:

$$\mathbf{a}_{k+6} = \eta \mathbf{a}_k, \quad \text{with } \eta = (1+i)/\sqrt{2} \quad \forall k = 0, 1, \dots, 5.$$

When using the Weyl group matrices, the constellation of the modulation (i.e. the possible complex values of the coefficients' matrices) is $\{\pm 1, \pm i, (\pm 1 \pm i)/\sqrt{2}, 0\}$ which is noted 4-QAM $\cup 0$. At time t , the symbol s_i^t of the matrix \mathbf{M}_T is transmitted over the antenna i . In the MCM system, as the dimensions of the matrices are $N_t \times T = 2 \times 2$, matrix \mathbf{M}_T is transmitted in 2 symbol-durations T_s . The signal received by antenna j is given by:

$$y_j^t = \sum_{i=1}^{N_t} h_{ij}^t s_i^t + n_j^t. \quad (1)$$

where noises n_j^t are modeled as independent samples of a zero-mean complex circularly symmetric Gaussian random variable with variance σ^2 . h_{ij}^t is the complex path gain between transmit antenna i and receive antenna j at time t . These coefficients are modeled as independent samples of a complex circularly symmetric Gaussian random variable with zero mean and variance of 0.5 per dimension. The fading is assumed to be constant over a temporal frame of length $L \times T_s$ and varies from one frame to another. Writing in matrix form, we obtain:

$$\mathbf{Y}_T = \mathbf{H}_T \mathbf{M}_\alpha + \mathbf{N}_T \quad (2)$$

\mathbf{Y}_T is the received matrix during 2 symbol-durations T_s on the 2 antennas between instants T and $(T + 2T_s)$. We assume a uniform power allocation at the transmission in order to

maintain a constant radiated power on the average of a space-time codeword duration.

The matrices of the Weyl group \mathcal{G}_w are very useful to our design. Firstly they are invertible and secondly they verify a specific criteria called "unique syndrome criteria" which vary from one scheme to another depending on the error-correcting code. In the matricial mapping block, the encoded bits are mapped directly into matrices using the detection criteria which is specific for each MCM scheme. This detection criteria is detailed in the sections III and IV where MCM scheme is used with the Hamming and Golay convolutional codes respectively. To simplify our study, matrices are chosen from the cosets \mathcal{C}_0 and \mathcal{C}_2 . In fact, a preliminary study of the MCM scheme was achieved using the small Hamming block code $H(8, 4, 4)$. In this particular model, the 4 useful information bits are permuted with $\pi_0 : (0, 1, 2, 3) \rightarrow (0, 1, 2, 3)$ and then mapped into the coset \mathcal{C}_0 . Similarly the 4 redundant bits are permuted with $\pi_2 : (0, 1, 2, 3) \rightarrow (0, 3, 2, 1)$ and then mapped into the coset \mathcal{C}_2 . The choice of the 2 permutations (π_0, π_2) and the 2 cosets ($\mathcal{C}_0, \mathcal{C}_2$) is not arbitrary. It was obtained by an exhaustive computing search. Indeed, having 16 possible codewords and 16 matrices in each coset, then for any codeword (c_0, c_1, \dots, c_7) generated by the $H(8, 4, 4)$, there is a unique couple of matrices $(\mathbf{M}_a, \mathbf{M}_b) \in \mathcal{C}_0 \times \mathcal{C}_2$ which verifies the equation below :

$$\mathbf{M}_\alpha \cdot \mathbf{M}_a^{-1} - \mathbf{M}_\beta \cdot \mathbf{M}_b^{-1} = 0 \quad (3)$$

where $(\mathbf{M}_\alpha, \mathbf{M}_\beta) \in \mathcal{C}_0 \times \mathcal{C}_2$ are the transmitted matrices. The Eq.3 has a unique solution:

$$(\mathbf{M}_a, \mathbf{M}_b) = (\mathbf{M}_\alpha, \mathbf{M}_\beta) \in \mathcal{C}_p \times \mathcal{C}_q \quad (4)$$

The 2×2 matrices \mathbf{M}_α and \mathbf{M}_β are transmitted consecutively on the 2 antennas during $4T_s$. Signals arriving at the 2 receive antennas undergo independent fading and can be expressed as follows:

$$\mathbf{Y}_T = \mathbf{H}_T \mathbf{M}_\alpha + \mathbf{N}_T \quad (5)$$

$$\mathbf{Y}_{T+1} = \mathbf{H}_{T+1} \mathbf{M}_\beta + \mathbf{N}_{T+1} \quad (6)$$

Assuming a constant block fading channel during $4T_s$ ($\mathbf{H}_T = \mathbf{H}_{T+1}$), and with the unicity of solution in Eq.(3) the implementation of the decoding algorithm consists of finding the couple $(\hat{\mathbf{M}}_a, \hat{\mathbf{M}}_b)$ solution of the following minimization:

$$(\hat{\mathbf{M}}_a, \hat{\mathbf{M}}_b) = \text{Arg} \min_{(\mathbf{M}_a, \mathbf{M}_b)} \|\mathbf{Y}_T \mathbf{M}_a^{-1} - \mathbf{Y}_{T+1} \mathbf{M}_b^{-1}\| \quad (7)$$

where $\|\mathbf{X}\|$, the Hilbert norm, is equal to $\text{Trace}(\mathbf{X}\mathbf{X}^H)$. With the bijective relation between a codeword c and a couple $(\mathbf{M}_\alpha, \mathbf{M}_\beta)$ we can then provide the 8 “best” coded bits of c and then the “best” 4 information bits. Computing the polynomial distribution of the Euclidean distances based on the detection criteria of Eq.7 we obtain:

$$D_H(x) = 1 + 14x^4 + x^8. \quad (8)$$

This polynomial distribution of the Euclidean distances also represents that of the $H(8, 4, 4)$ based on the Hamming distance which is an important result. That is why it is interesting to expand our study to adapt MCM schemes with convolutional code with higher minimum Hamming distance and using the same group of matrices. In the next 2 sections, we will study the MCM scheme with the Hamming and Golay convolutional code obtained by unwrapping the ‘k-states’ tail-biting trellises of the Hamming code ($n = 8, k = 4, d_{\min} = 4$) and the Golay code ($n = 24, k = 12, d_{\min} = 8$) respectively.

III. MCM WITH THE HAMMING CONVOLUTIONAL CODE

We introduce below the 2×2 -MCM scheme with a small convolutional error-correcting code built by unwrapping the 4-states “tail-biting” or circular trellis of the Hamming code ($n = 8, k = 4, d_{\min} = 4$). Its small encoder is shown below in Fig.2.

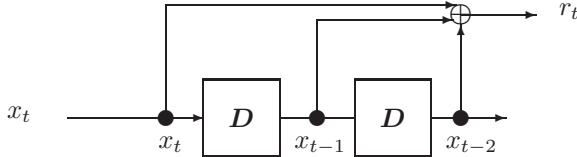

Fig. 2. Hamming convolutional 2-bits state encoder

Useful information bits are presented in sequence $(\dots, x_{t-1}, x_t, x_{t+1}, \dots)$ and are encoded to produce a sequence of redundant bits $(\dots, r_{t-1}, r_t, r_{t+1}, \dots)$. In order to do the matricial mapping, information and redundant bits are grouped by group of 4 bits such as $(x_t, r_t, x_{t+1}, r_{t+1})$. Encoding and decoding algorithms is done on a 4-state trellis whose branches are labeled by 4 bits shown in Fig. 3. The pair of cosets $(\mathcal{C}_0, \mathcal{C}_2)$ and the permutations $\pi_0 : (0, 1, 2, 3) \rightarrow (0, 1, 2, 3)$ and $\pi_2 : (0, 1, 2, 3) \rightarrow (0, 3, 2, 1)$ are used in the matricial mapping block. Having 16 matrices in each coset and 16 possible combinations of 4 bits, each trellis section is a complete bipartite graph. Each group of 4 bits on a branch of the trellis has its proper corresponding matrix in the appropriate coset. Matrices are selected alternatively in cosets \mathcal{C}_0 and \mathcal{C}_2 and are then transmitted serially on the 2 antennas $(\dots, \mathbf{M}_{T-1}, \mathbf{M}_T, \mathbf{M}_{T+1}, \dots) \in \dots \times \mathcal{C}_0 \times \mathcal{C}_2 \times \mathcal{C}_0 \times \dots$

Fig. 4 explains the decoding algorithm of the Hamming MCM (H-MCM) convolutional scheme. We use a variant of the Viterbi algorithm [1] by modifying the metric computation

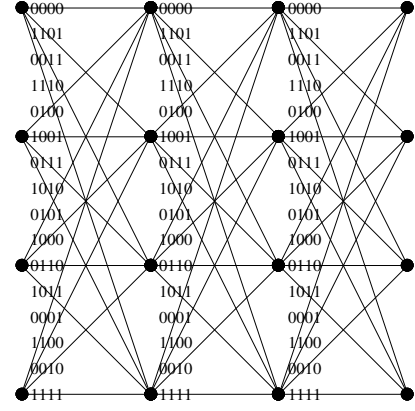

Fig. 3. 4-state trellis of the convolutional Hamming code.

on each branch of the trellis such as:

$$\gamma_T(\mathbf{M}_b) = \min_{(\mathbf{M}_a, \mathbf{M}_c)} \{ (\lambda \|\mathbf{Y}_{T-1}\mathbf{M}_a^{-1} - 2\mathbf{Y}_T\mathbf{M}_b^{-1} + \mathbf{Y}_{T+1}\mathbf{M}_c^{-1}\| + \mu \|\mathbf{Y}_T - \hat{\mathbf{H}}_T\mathbf{M}_b\|) \} \quad (9)$$

λ and μ are adaptive weights over iterations to merge the minimization of the channel variations and the minimization of the Euclidean distance between received and transmitted signals. When no CSI is available at the receivers, $(\lambda, \mu) = (1, 0)$. Iterative decoding with an appropriate channel estimation corresponds to $(\lambda, \mu) = (p, 1 - p)$ with $0 \leq p \leq 1$. The estimated values \hat{H}_T are the estimations of the channel matrix associated with each branch of the trellis and they are given by:

$$\hat{\mathbf{H}}_T(\hat{\mathbf{M}}_b) = (\mathbf{Y}_{T-1}\hat{\mathbf{M}}_a^{-1} + 2\mathbf{Y}_T\hat{\mathbf{M}}_b^{-1} + \mathbf{Y}_{T+1}\hat{\mathbf{M}}_c^{-1})/4 \quad (10)$$

After evaluating the metrics of the branches $\gamma_T(\mathbf{M}_b)$, we compute the metric states classically as in the Viterbi algorithm:

$$\Gamma(s_T) = \min_{\mathbf{M}_b} (\Gamma(s_{T-1}) + \gamma_T(\mathbf{M}_b)) \quad (11)$$

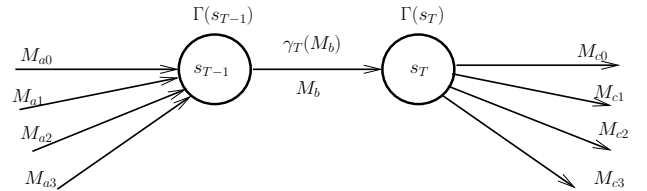

Fig. 4. Schematic of computing label paths of the MCM Hamming convolutional decoding algorithm

The polynomial distribution of the Euclidean distances referring to the metric in Eq.11 is:

$$D_{\text{Hamming}}(X) = 1 + 2X^{12} + X^{20} \quad (12)$$

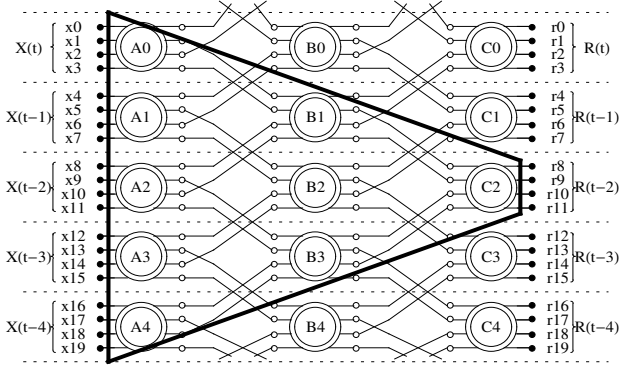

Fig. 5. Schematic of the block code (40, 20, 8)

IV. MCM WITH GOLAY CONVOLUTIONAL CODE

In this section, we present a new encoder/decoder of the MCM scheme with a new form of the Golay convolutional code built by unwrapping the 16-states tail-filtering trellises of the Golay(24, 12, 8) block code first described in [14] [15]. A Tanner graph of the code(40, 20, 8) based on the construction detailed in [14] is showed in Fig.5. Each constraint (A_i, B_i, C_i) has 4 input bits $(x_i, x_{i+1}, x_{i+2}, x_{i+3})$ and 4 output bits $(r_i, r_{i+1}, r_{i+2}, r_{i+3})$. From this code, we can derive a 16-states section trellis built from an horizontal slice of constraints (A_i, B_i, C_i) , each section being connected to 4 bits of information and 4 bits of redundancy [14]. The corresponding state encoder is shown in Fig.6. This encoder transforms a $5 \times 4 = 20$ information bits $(X_t, X_{t-1}, X_{t-2}, X_{t-3}, X_{t-4})$ sliding window into a sliding window in systematic form of 4 information bits and 4 redundant bits (R_{t-2}, X_{t-2}) . Thereafter we give the transpose of the generator matrix G^T which transforms the 20 information bits $(x_0, x_1, \dots, x_{19})$ into the 4 redundant bits $(r_8, r_9, r_{10}, r_{11})$ in Fig.5.

$$G^T = \begin{bmatrix} 1 & 1 & 0 & 1 & 1 & 0 & 1 & 0 & 1 & 1 & 1 & 1 & 1 & 1 & 1 & 0 & 1 & 0 & 1 & 1 \\ 0 & 0 & 0 & 0 & 1 & 1 & 0 & 1 & 1 & 1 & 0 & 1 & 0 & 1 & 0 & 1 & 1 & 0 & 1 & 1 \\ 1 & 1 & 0 & 1 & 1 & 0 & 1 & 0 & 1 & 0 & 1 & 1 & 1 & 0 & 1 & 1 & 0 & 0 & 0 & 0 \\ 1 & 1 & 0 & 1 & 0 & 1 & 1 & 1 & 1 & 1 & 1 & 1 & 0 & 1 & 0 & 1 & 1 & 0 & 1 & 1 \end{bmatrix}$$

This matrix G is the generator matrix of the Golay convolutional encoder of Fig.6. In the Golay-MCM convolutional scheme (G-MCM), each branch of trellis (Fig.7) is labeled by a group of 8 coded bits (R_{t-2}, X_{t-2}) which correspond to the transmission of 2 matrices $(M_a, M_b) \in (\mathcal{C}_0 \times \mathcal{C}_2)$. Using the same decoding algorithm as the H-MCM we compute the new branch metric as:

$$\begin{aligned} \gamma_T(\mathbf{M}_T^a, \mathbf{M}_T^b) = & \min_{((\mathbf{M}_{T-1}^a, \mathbf{M}_{T-1}^b), (\mathbf{M}_{T+1}^a, \mathbf{M}_{T+1}^b))} \\ & \lambda(\|\mathbf{M}_{T-1} - 2\mathbf{M}_T + \mathbf{M}_{T+1}\|) \\ & + \lambda(\|\mathbf{P}_{T-1}\| + \|\mathbf{P}_T\| + \|\mathbf{P}_{T+1}\|) \\ & + \mu(\|\mathbf{Y}_T^a - \hat{\mathbf{H}}_T^a \mathbf{M}_T^a\| + \|\mathbf{Y}_T^b - \hat{\mathbf{H}}_T^b \mathbf{M}_T^b\|) \end{aligned} \quad (13)$$

where

$$\begin{aligned} \mathbf{M}_T &= \mathbf{Y}_T^a (\mathbf{M}_T^a)^{-1} + \mathbf{Y}_T^b (\mathbf{M}_T^b)^{-1} \\ \mathbf{P}_T &= 2\mathbf{Y}_T^a (\mathbf{M}_T^a)^{-1} - 2\mathbf{Y}_T^b (\mathbf{M}_T^b)^{-1} \end{aligned}$$

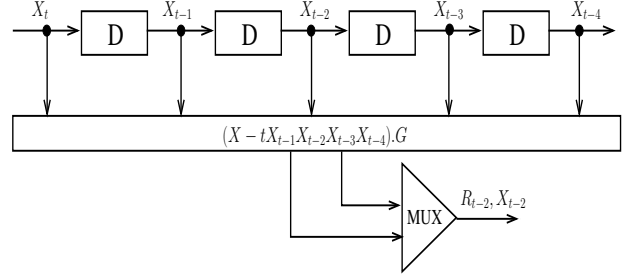

Fig. 6. State machine of the systematic Golay convolutional encoder

Like the H-MCM scheme, λ and μ are adaptive weights over iterations. $\hat{\mathbf{H}}_T^a$ and $\hat{\mathbf{H}}_T^b$ are the estimated values of the channel matrix associated with each branch of the trellis and they are given by:

$$\begin{aligned} \hat{\mathbf{H}}_T^a(\hat{\mathbf{M}}_T^a) = & [\mathbf{Y}_{T-1}^a (\hat{\mathbf{M}}_{T-1}^a)^{-1} + \mathbf{Y}_{T-1}^b (\hat{\mathbf{M}}_{T-1}^b)^{-1} \\ & + 2\mathbf{Y}_T^a (\hat{\mathbf{M}}_T^a)^{-1} + \mathbf{Y}_{T+1}^a (\hat{\mathbf{M}}_{T+1}^a)^{-1} + \mathbf{Y}_{T+1}^b (\hat{\mathbf{M}}_{T+1}^b)^{-1}] / 6 \end{aligned} \quad (14)$$

Similarly for $\hat{\mathbf{H}}_T^b$:

$$\begin{aligned} \hat{\mathbf{H}}_T^b(\hat{\mathbf{M}}_T^b) = & [\mathbf{Y}_{T-1}^a (\hat{\mathbf{M}}_{T-1}^a)^{-1} + \mathbf{Y}_{T-1}^b (\hat{\mathbf{M}}_{T-1}^b)^{-1} \\ & + 2\mathbf{Y}_T^b (\hat{\mathbf{M}}_T^b)^{-1} + \mathbf{Y}_{T+1}^a (\hat{\mathbf{M}}_{T+1}^a)^{-1} + \mathbf{Y}_{T+1}^b (\hat{\mathbf{M}}_{T+1}^b)^{-1}] / 6 \end{aligned} \quad (15)$$

The polynomial distribution of the Euclidean distances between coded sequence of signals based on the metric criteria of Eq.13 is:

$$D_{Golay}(X) = 1 + 2X^{52} + 2X^{56} + 2X^{68} + X^{72} + 4X^{84} + 4X^{88} \quad (16)$$

The minimal distance for G-MCM convolutional code is now 52 while it was 12 for the H-MCM convolutional code. This will improve clearly the performance as we will see later in the discussion of simulations results.

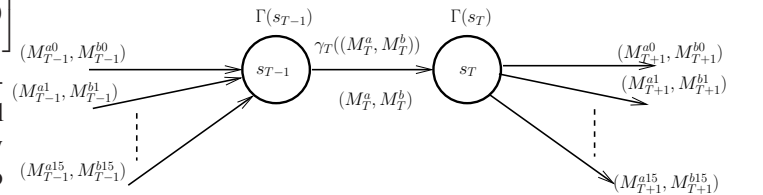

Fig. 7. Schematic of computing label paths of the MCM Golay convolutional decoding algorithm

V. SIMULATIONS AND RESULTS

Fig.8 shows simulation results in terms of Bit Error Rate (BER) versus the Energy-per-Bit to Noise ratio (E_b/N_0) for different 2×2 -MIMO schemes. We assume a quasi-static block fading channel on a frame of $L = 128$ message bits and varying independently from one frame to another. H-MCM and G-MCM refers to Hamming convolutional MCM and Golay convolutional MCM schemes described in section III and IV respectively. We compare the non-coherent MCM schemes with the 2×2 differential

Alamouti concatenated with the same convolutional code and in which the conventional detector (CD) described in section I is the detection criteria.

When perfect CSI is assumed, we notice that the H-MCM scheme induces a loss of about $0.5dB$ at $BER = 10^{-3}$ compared to the Alamouti coherent scheme. However the G-MCM scheme induces a coding gain of about $0.25dB$ at $BER = 10^{-3}$ compared to the 2×2 Alamouti since the Golay convolutional has a higher constraint length. When no channel information is available at receivers, the MCM convolutional scheme doesn't perform well on the first iteration $(\lambda, \mu) = (1, 0)$ compared with the differential Alamouti systems. The G-MCM scheme present a significant gain of about $3dB$ at $BER = 10^{-2}$ in comparison to H-MCM scheme. This can be explained referring to Eq.16 and Eq. 13 in which we found that the minimal Euclidean distance of the G-MCM scheme is 52 while it is 12 for the Hamming convolutional scheme. When using channel estimates in a second iteration $(\lambda, \mu) = (0.5, 0.5)$, performance of H-MCM and G-MCM schemes are both improved especially at high E_b/N_0 . Although we didn't use pilot symbols for the channel estimation, the performance of G-MCM scheme tends to the differential Alamouti scheme. the 2 described MCM schemes don't reach the performance of differential Alamouti scheme from the first iteration, it is clear that with more iterations and with a better channel estimates, performance may be improved.

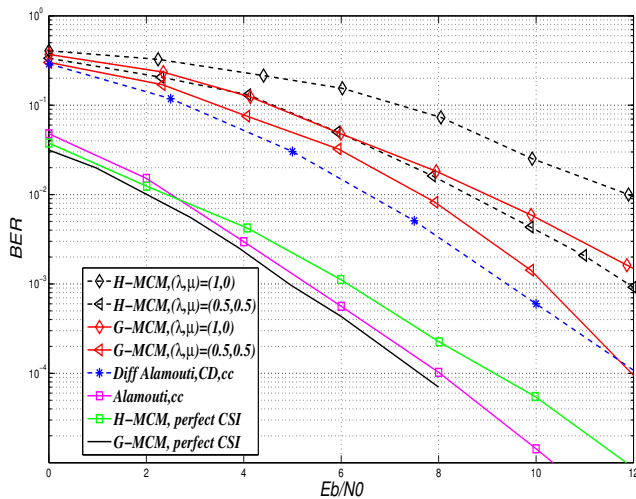

Fig. 8. MCM with Hamming and Golay convolutional code, $L=128$

VI. CONCLUSIONS AND PERSPECTIVES

In this paper, we have described a new MIMO coding scheme called Matrix Coded Modulation "MCM", merging MIMO encoding and coded modulation in order to transmit data over wireless communication channels without inserting pilot symbols to estimate the channel. The application of this MCM scheme would be very interesting especially when used with an appropriate channel error-correcting code with a high minimal Hamming distance. The relation between the minimal Hamming distance of the channel error correcting code and the

minimal Euclidean distance referring to the detection criteria is being under study. Also a study of the construction of matrices is a future goal to optimize this new scheme in terms of diversity and coding gain. The goal of this research is to gain partially and asymptotically the performance degradation of non-coherent existing schemes compared to coherent ones but without any CSI at the receivers and assuming a slow varying wireless channel.

REFERENCES

- [1] G.D. Forney Jr., *The Viterbi Algorithm*, Proceedings of the IEEE, Vol.61, no.3, pp.268-278, March 1973.
- [2] L. Bahl, J. Cocke, F. Jelinek and J. Raviv, *Optimal Decoding of Linear Codes for Minimizing Symbol Error Rates*, IEEE Transactions on Information Theory, Vol.20, no.2, pp.284-287, March 1974.
- [3] F.J. MacWilliams and N.J.A. Sloane *The Theory of Error-Correcting Codes*, Ed. North-Holland, 1977, Chapter 19, Paragraph 3.
- [4] D. Divsalar and M.K Simon *Multiple Treillis Coded Modulation(MTCM)*, IEEE Transactions on Communications, Vol.36, no.4, pp.410-419, April 1988.
- [5] C. Berrou, A. Glavieux and P.Thitimajshima, *Near Shannon Limit Error-Correcting and Decoding: Turbo-Codes*, in Proceedings of the IEEE International Conference on Communications (ICC'93), pp.1064-1070, Geneva(Switzerland), May 1993.
- [6] P. Robertson, P. Hoher and E. Vilebrun, *Optimal and Sub-Optimal Maximum A Posteriori Algorithms Suitable for Turbo Decoding*, European Transactions on Telecommunications (ETT), Vol.8, no.2, pp.119-125, March-April 1997.
- [7] S. Alamouti, *A Simple Transmit Diversity Technique for Wireless Communications*, IEEE J. Select. Areas Communication, Vol.16, pp. 1451-1458, Oct. 1998.
- [8] A.R. Calderbank, G.D. Forney Jr. and A. Vardy, *Minimal Tail-Biting Trellises: The Golay Code and More*, IEEE Transactions on Information Theory, Vol.45, no.5, pp.1435-1455, July 1999.
- [9] V. Tarokh, H. Jafarkhani, and A.R. Calderbank, *Spacetime Block Codes from Orthogonal Designs*, IEEE trans. Inf. Theory, Vol.45, no. 5 pp. 1456-1467, Oct. 1999.
- [10] B.M. Thomas and L.Marzetta, *Differential Unitary Space-Time Modulation for Multiple-Antenna Communications in Rayleigh Flat Fading*, IEEE Transactions on Information Theory, Vol.46, no.2, March 2000.
- [11] V. Tarokh and H.Jafarkhani, *A Differential Detection Scheme for Transmit Diversity*, IEEE Journal on Selected Areas in Communications, Vol.18, no.7, pp.1169-1174, July 2000.
- [12] B.L. Hughes, *Differential Space-Time Modulation*, IEEE transactions on Information Theory, vol.46, no.7, pages 2567-2578, November 2000.
- [13] B.M. Hochwald and W. Sweldens, *Differential Unitary Space-Time Modulation*, IEEE Transactions on Communications, Vol.48, no.12, Dec 2000.
- [14] E. Cadic, and J.C. Carlach and G. Olocco and A. Otmani and J.P. Tillich, *Low Complexity Tail-Biting Trellises of Self-dual codes of Length 24, 32 and 40 over GF(2) and Z4 of Large Minimum Distance*, Proceedings of the 14th International Symposium on Applied Algebra, Algebraic Algorithms and Error-Correcting Codes,AAECC-14, pages 57-66, 2001.
- [15] J-C. Carlach and A. Otmani, *A Systematic Construction of Self-Dual Codes*, IEEE transactions on Information Theory, vol.49, no.11, pages 3005-3009, November 2003.
- [16] B. Le Saux, M. Héland and P-J. Bouvet, *Comparison of Coherent and Non-Coherent Space-Time Schemes for Frequency Selective Fast Varying Channels*, International Symposium on Wireless Communication Systems (ISWCS'05), Sienna, Italy, September 2005
- [17] B. Le Saux, *Estimation de canal pour systèmes multi-antennes multi-porteuses*, Ph.D. Thesis, Rennes-I University/INSA-Rennes, 25th october 2007.
- [18] V. Pauli, J. Cocke, L. Lampe and J. Huber, *Differential Space-Frequency Modulation and Fast 2-D Multiple-Symbole Differential Detection for MIMO-OFDM*, IEEE Transactions on Vehicular Technology, Vol.57, no.1, pp.297-310, January 2008.