



**HAL**  
open science

## Identification for robust deconvolution filtering

Xavier Bombois, Håkan Hjalmarsson, Gérard Scorletti

► **To cite this version:**

Xavier Bombois, Håkan Hjalmarsson, Gérard Scorletti. Identification for robust deconvolution filtering. *Automatica*, 2010, 46 (3), pp.577-584. hal-00655789

**HAL Id: hal-00655789**

**<https://hal.science/hal-00655789>**

Submitted on 2 Jan 2014

**HAL** is a multi-disciplinary open access archive for the deposit and dissemination of scientific research documents, whether they are published or not. The documents may come from teaching and research institutions in France or abroad, or from public or private research centers.

L'archive ouverte pluridisciplinaire **HAL**, est destinée au dépôt et à la diffusion de documents scientifiques de niveau recherche, publiés ou non, émanant des établissements d'enseignement et de recherche français ou étrangers, des laboratoires publics ou privés.

# Identification for robust $H_2$ deconvolution filtering

Xavier Bombois<sup>a</sup> Håkan Hjalmarsson<sup>b</sup> Gérard Scorletti<sup>c</sup>

<sup>a</sup>*Delft Center for Systems and Control, Mekelweg 2, 2628 CD Delft, The Netherlands*

<sup>b</sup>*ACCESS Linnaeus Center, Electrical Engineering, KTH – Royal Institute of Technology, S-100 44 Stockholm, Sweden*

<sup>c</sup>*Laboratoire Ampère, Ecole Centrale de Lyon, 36 avenue Guy de Collongue - 69134 Ecully Cedex, France*

---

## Abstract

This paper addresses robust deconvolution filtering when the system and noise dynamics are obtained by parametric system identification. Consistent with standard identification methods, the uncertainty in the estimated parameters is represented by an ellipsoidal uncertainty region. Three problems are considered: 1) Computation of the worst case  $H_2$  performance of a given deconvolution filter in this uncertainty set. 2) Design of a filter which minimizes the worst case  $H_2$  performance in this uncertainty set. 3) Input design for the identification experiment, subject to a limited input power budget, such that the filter in 2) gives the smallest possible worst-case  $H_2$  performance. It is shown that there are convex relaxations of the optimization problems corresponding to 1) and 2) while the third problem can be treated via iterating between two convex optimization problems.

---

## 1 Introduction

In many applications it is of interest to estimate the input to a dynamical system given measurements of the output, examples include seismic signal processing [12], telecommunication [8], etc. Compounding factors are that in general measurements are noise corrupted and, furthermore, that the system through which the signal passes is not known exactly but uncertain. In deconvolution filtering the original signal is estimated by filtering the measured signal(s) through a filter. The measured signal is  $\{y\}$  which is given by  $y(t) = G_0(z)u(t) + H_0(z)e(t)$  where  $G_0$  is the dynamics of the system through which  $\{u\}$  passes and where the term  $H_0(z)e(t)$  represents an aggregation of disturbances, modelled as zero mean white noise  $\{e\}$  filtered through some dynamics  $H_0$ . The measured signal  $y$  is filtered through the causal deconvolution filter  $F$ , resulting in the estimate  $\hat{u}(t - n_k) = F(z)y(t)$ . The delay  $n_k$  corresponds to the degree of non-causality (or smoothing) that will be allowed in the filtering.

In the sequel, we will suppose that all signals are wide-sense stationary and that the power spectrum  $\Phi_u(\omega)$  of the signal  $u(t)$  is given by  $\Phi_u(\omega) = |W_u(e^{j\omega})|^2$  with  $W_u(z)$  being a known stable transfer function. The variance of  $e(t)$  is denoted by  $\sigma_e^2$ . We assume that  $u$  and  $e$  are independent. We will also assume that  $G_0$  and  $H_0$  are stable linear time invariant systems and  $H_0$  is further assumed to be inversely stable and monic.

The filter  $F(z)$  should be designed in order to give an accurate estimate of the input signal. By this we mean an estimate such that the mean-square error  $J_0(F) = \bar{\mathbf{E}} [(\hat{u}(t) - u(t))^2] := \lim_{N \rightarrow \infty} \frac{1}{N} \sum_{t=1}^N \mathbf{E} [(\hat{u}(t) - u(t))^2]$  is small. When the system  $G_0$  and noise dynamics  $H_0$  are perfectly known, the Wiener filter is the optimal filter.

When  $G_0$  and  $H_0$  are uncertain, the filter  $F$  should be robust, i.e. it should give good (but maybe not optimal) performance for any system in the class of systems (i.e. the uncertainty region) to which  $G_0$  and  $H_0$  may belong. There is a rich literature on robust filtering in general, see, e.g., [6, 15, 13], and also on robust deconvolution filtering, see [4, 5]. This contribution is nevertheless the first one to our knowledge which investigates the robust filtering problem in combination with system identification. We will indeed consider the case where prediction error identification in a full-order model structure [11] has delivered the uncertainty regions containing  $G_0 = G(z, \theta_0)$  and  $H_0 = H(z, \theta_0)$  at a certain user-chosen probability level. These uncertainty regions are parametric:

$$\begin{aligned} G_0(z) &\in \mathcal{D}_G = \{G(z, \theta) \mid \theta \in U\} \\ H_0(z) &\in \mathcal{D}_H = \{H(z, \theta) \mid \theta \in U\} \end{aligned} \quad (1)$$

where  $U$  is an ellipsoid in the parameter space centered at the identified parameter vector  $\hat{\theta}_N$  and shaped by the inverse  $R$  of the covariance matrix  $P_\theta$  of  $\hat{\theta}_N$ :

$$U = \{\theta \mid (\theta - \hat{\theta}_N)^T R (\theta - \hat{\theta}_N) < \chi\} \quad (2)$$

where  $\chi$  is a constant related to the desired probability level  $Pr(\theta_0 \in U)$  and  $R$  can be estimated from the data [11]. This ellipsoid  $U$  thus characterizes the uncertainty of both  $G$  and  $H$ . To the best of the authors' knowledge, the use of parametric ellipsoidal uncertainty in robust  $H_2$ -deconvolution filtering is new. Consequently, the first technical contribution of this paper is to give a solution for the robust  $H_2$  deconvolution problem with such uncertainty description. To do so, we adopt the dynamic multiplier approach of [13] since, as stressed in [13], this is the least conservative and the most universally applicable of the existing methods. Our contribution is to deduce an appropriate factorization of the dynamic multiplier for the nonstandard uncertainty (2) and to adapt the continuous-time results of [13] to the case of discrete-time systems as considered in prediction error identification.

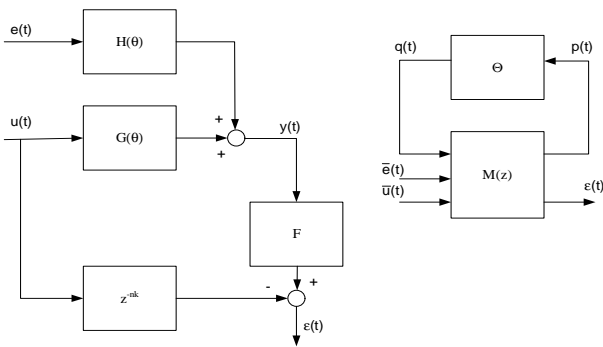

Fig. 1. Filter to be analyzed (left) and corresponding LFT loop (right).

More specifically, let us consider Figure 1 (left-hand side) where the true system has been replaced by  $G(z, \theta)$  and  $H(z, \theta)$  for one arbitrary  $\theta \in U$  and let us define  $J(\theta, F) = \bar{\mathbf{E}}[\epsilon^2(t, \theta)]$  where  $\epsilon(t, \theta) \triangleq F(z)(G(z, \theta)u(t) + H(z, \theta)e(t)) - u(t - n_k)$ . We have thus that  $J_0(F) < \gamma$  if  $J(\theta, F) < \gamma \forall \theta \in U$ . Given this set-up, we will study the following two problems:

**1. Performance validation.** Given a filter  $F(z)$  and an uncertainty region  $U$ , verify that  $J(\theta, F) < \gamma \forall \theta \in U$  for some given  $\gamma$ . We are in fact interested by the smallest  $\gamma$  for which the latter holds (i.e. the worst case performance achieved by the filter over the plants described by a  $\theta$  in  $U$ ). This worst case performance  $J_{WC}$  is thus the solution  $\gamma_{\text{opt}}$  of the following optimization problem:

$$\begin{aligned} & \min_{\gamma} \gamma \\ & \text{s.t. } J(\theta, F) < \gamma, \quad \forall \theta \in U \end{aligned} \quad (3)$$

**2. Robust  $H_2$  filter design.** Given an uncertainty region  $U$ , determine a filter  $F$  such that  $J(\theta, F) < \gamma \forall \theta \in U$  for the smallest possible  $\gamma$ . The to-be-designed filter  $F$  is thus the solution  $F_{\text{opt}}$  of the following optimization problem:

$$\begin{aligned} & \min_{\gamma, F} \gamma \\ & \text{s.t. } J(\theta, F) < \gamma, \quad \forall \theta \in U \end{aligned} \quad (4)$$

In this paper, we will restrict attention to filters with pre-specified state-space matrices  $A_F$  and  $B_F$ . This covers, e.g., FIR filters, which are commonly used in Telecommunications applications, but also Laguerre and Kautz filters.

**3. Optimal input design for robust filtering.** Finally, we will also analyze a third problem: the optimal design of the identification experiment leading to  $U$ . An important characteristic of the uncertainty ellipsoid  $U$  is indeed that it is dependent on the experimental conditions of this identification experiment. These experimental conditions are the number  $N$  of input-output data and the spectrum  $\Phi_{u_{\text{id}}}(\omega)$  of the excitation signal  $u_{\text{id}}$  used during the identification. The subscript id in  $\Phi_{u_{\text{id}}}(\omega)$  is there to distinguish the input signal during the identification (i.e.  $u_{\text{id}}$ ) and the one that has to be reconstructed (i.e.  $u$ ). In this paper, we will suppose that the number of data is given and  $U$  will therefore be only dependent on  $\Phi_{u_{\text{id}}}(\omega)$ . To show this dependence,  $U$  will be also sometimes denoted by  $U(\Phi_{u_{\text{id}}})$ . More details on the relation between  $\Phi_{u_{\text{id}}}$  and  $U(\Phi_{u_{\text{id}}})$  will be given in Section 4.

Suppose that there is a constraint on the maximal power for the excitation signal  $u_{\text{id}}$  for the identification experiment, which is supposed to be conducted in open loop. Suppose also, as mentioned above, that the number  $N$  of data is given. The optimal experiment design problem consists in this case of determining the input spectrum  $\Phi_{u_{\text{id}}}$  of  $u_{\text{id}}$  that delivers an uncertainty region  $U(\Phi_{u_{\text{id}}})$  for which the corresponding robust filter  $F$  leads to the smallest worst case performance. The optimal  $\Phi_{u_{\text{id}}}$  is the solution  $\Phi_{u_{\text{id}}}^{\text{opt}}$  of the following optimization problem:

$$\min_{\gamma, F, \Phi_{u_{\text{id}}}} \gamma \quad (5)$$

$$\text{s.t. } J(\theta, F) < \gamma \quad \forall \theta \in U(\Phi_{u_{\text{id}}}) \quad (6)$$

$$\frac{1}{2\pi} \int_{-\pi}^{\pi} \Phi_{u_{\text{id}}}(\omega) d\omega < \alpha \quad (7)$$

where  $\alpha$  represents the maximum allowed power. The corresponding robust filter is then given by the optimal filter  $F_{\text{opt}}$  in the same optimization problem.

It is important to note that the topic of this paper, in general, and our optimal input design problem for robust filtering, in particular, can be related to the problem of designing optimal training sequences for wireless communication systems [10]. These training sequences are used to identify a model of the communication channel that can be subsequently used to design a filter for the reconstruction of the emitted signal from the received signal. The problem considered in [10] is nevertheless restricted to static transfer functions  $G_0$  and the objective of optimizing the performance of the reconstruction

filter (used in the above formulation) is replaced by a simpler criterion on the matrix  $R$  defining  $U$ .

The three problems presented above will be covered in the ensuing three sections. Section 5 contains a numerical illustration and the paper is concluded in Section 6.

## 2 Validation problem

### 2.1 Reformulation in the LFT framework

The validation problem (3) is basically a robustness analysis problem. Solving such a problem requires to reformulate it in the LFT framework where the uncertain elements (i.e. the parameter vector  $\theta$  in our case) are separated from the other elements [17]. For this purpose, let us first take a look at Figure 1. Since  $e$  and  $u$  are independent and since  $\Phi_u(\omega) = |W_u(e^{j\omega})|^2$ , we can say that  $u(t) = W_u(z)\bar{u}(t)$  and  $e(t) = \sigma_e\bar{e}(t)$  with  $\bar{u}(t)$  and  $\bar{e}(t)$  independent white noises with unit variance. Consequently, the cost function  $J(F, \theta)$  is equal to the squared  $H_2$ -gain of the vector of transfer functions:

$$\mathcal{V}(z) = \begin{bmatrix} \sigma_e F(z)H(z, \theta) \\ ((F(z)G(z, \theta)) - z^{-n_k})W_u(z) \end{bmatrix}$$

which is the transfer function between  $\begin{bmatrix} \bar{e}(t) \\ \bar{u}(t) \end{bmatrix}$  and  $\epsilon(t)$ . We have thus:

$$J(F, \theta) = \|\mathcal{V}(z)\|_2^2 := \frac{1}{2\pi} \int_{-\pi}^{\pi} \text{Trace}(\mathcal{V}^*(e^{j\omega})\mathcal{V}(e^{j\omega})) d\omega$$

The different parametrizations of  $G(z, \theta)$  and  $H(z, \theta)$  which are commonly used in prediction error identification (ARX, BJ,... structures) [11] can all be expressed as:

$$G(z, \theta) = \frac{Z_1\theta}{1 + Z_2\theta} \quad H(z, \theta) = \frac{1 + Z_3\theta}{1 + Z_4\theta} \quad (8)$$

with  $Z_i(z)$  row vectors of dimension  $k$  containing only delays and zeros and  $\theta \in \mathbf{R}^{k \times 1}$ . We observe that both  $G(z, \theta)$  and  $H(z, \theta)$  can be easily transformed into an LFT in  $\theta$  [17]. Consequently, the transfer function between  $v(t) := \begin{bmatrix} \bar{e}(t) \\ \bar{u}(t) \end{bmatrix}$  and  $\epsilon(t)$  can be easily rewritten both as an LFT in  $\Theta_{\text{bis}} = \text{Diag}(\theta, \theta)$  ( $\theta \in \mathbf{R}^k$ ) and as an LFT in  $\Theta = \text{Diag}(\Delta\theta, \Delta\theta)$  ( $\Delta\theta := \theta - \hat{\theta}_N$ ). It is to be noted that the uncertainty structure  $\Theta$  in this problem is similar to the one we obtain from identification of MIMO systems (see our previous contribution [1]). Thus, we have that

$$\begin{bmatrix} p \\ \epsilon \end{bmatrix} = \overbrace{\begin{bmatrix} M_{11} & M_{12} \\ M_{21} & M_{22} \end{bmatrix}}^{=M(z)} \begin{bmatrix} q \\ v \end{bmatrix}, \quad q = \overbrace{\begin{bmatrix} \Delta\theta & 0 \\ 0 & \Delta\theta \end{bmatrix}}^{=\Theta} p \quad (9)$$

(see the right-hand side of Figure 1), which is an LFT transformation. We will use the notation  $\epsilon(t) = \mathcal{F}(M(z), \Theta)v(t)$ .

Based on what has been developed above, Problem 1 (see (3)) can be reformulated as follows:

$$\begin{aligned} \min_{\gamma} \quad & \gamma \\ \text{s.t.} \quad & \|\mathcal{F}(M(z), \Theta)\|_2^2 < \gamma \quad \forall \theta \in U \end{aligned} \quad (10)$$

with  $\Theta$  as in (9).

To be able to develop some of the coming results, it will be necessary to make the following two assumptions.

**Assumption 1** *The transfer functions  $G(z, \theta)$  and  $H(z, \theta)$  are stable for all  $\theta \in U$ .*

**Assumption 2** *The transfer matrix  $M_{12}(z)$  in (9) has no direct term i.e.  $M_{12}(z)$  contains at least one delay.*

Recall that we have assumed that both  $G_0(z)$  and  $H_0(z)$  are stable. Assumption 1 states thus that the systems in the uncertainty regions (1) for  $G_0$  and  $H_0$  are also stable. Given an uncertainty  $U$ , Assumption 1 can be easily verified using the results in [7]. If, for a given  $U$ , we conclude that Assumption 1 does not hold, then we can also conclude that the worst case performance  $J_{WC}$  (the solution of (3)) is equal to infinity. Assumption 2 is also not restrictive since, given the parametrization (8) where the vectors  $Z_i(z)$  have no direct terms, the LFT relation (9) can always be chosen such that the matrix  $M_{12}(z)$  has no direct term.

### 2.2 Multiplier describing the uncertainty

As mentioned in the introduction, we will solve (10) using an approach based on dynamic multipliers. For this purpose, we need to define a very general affine parametrization of the set of hermitian matrices  $\Pi$  satisfying:

$$\theta \in U \implies \begin{bmatrix} \Theta \\ I \end{bmatrix}^T \Pi \begin{bmatrix} \Theta \\ I \end{bmatrix} > 0 \quad (11)$$

The matrix  $\Pi$  is a representation of the structure of the uncertainty  $\Theta$  and is called multiplier (see e.g. [14]). Robustness problems can generally be solved by solving an LMI system where it is required to find a family of these multipliers  $\Pi$  i.e. one multiplier for each frequency (dynamic multiplier). This family will be represented by introducing the frequency-dependent notation:  $\Pi(\omega)$ . For  $H_2$  analysis problems such as in (10), this frequency dependence will have to take the form of the frequency response of a matrix of transfer functions. More precisely, we will need a factorized version of  $\Pi(\omega)$  of the form:

$$\Pi(\omega) = \Psi^*(e^{j\omega}) P \Psi(e^{j\omega}) \quad (12)$$

where  $P = P^T$  is a frequency-independent matrix and  $\Psi(z)$  is a matrix of stable transfer functions.

An appropriate expression for the multiplier  $\Pi(\omega)$  of the nonstandard uncertainty set  $\Theta$  has been developed in our

recent contribution [1]. However, in that paper, treating an  $H_\infty$  analysis problem, the factorization (12) was circumvented by using a gridding of the frequency range. The factorization of this multiplier is therefore a contribution of this paper and is given in Proposition 1 whose proof is given in Appendix A.

**Proposition 1** Consider the uncertainty  $\Theta$  defined in (9) with  $\theta \in U$  (see (2)). Define the vector  $\mathcal{B}(z) = (\mathcal{B}_0 \ \mathcal{B}_1 \ \mathcal{B}_2 \ \dots \ \mathcal{B}_b)^T$  containing basis functions  $\mathcal{B}_i(z)$  ( $i = 0 \dots b$ ) for some user-chosen positive integer  $b$ . Restricting the parametrization of the frequency dependence to functions that can be written as linear combination of  $\mathcal{B}_i(e^{j\omega})$  and  $\mathcal{B}_i^*(e^{j\omega})$  ( $i = 0 \dots b$ ), the multiplier  $\Pi(\omega)$  satisfying (11) can be factorized into (12) with:

$$\Psi(z) = \begin{pmatrix} \mathcal{B}(z) \otimes I_{2k} & 0 \\ 0 & \mathcal{B}(z) \otimes I_2 \\ I_{2k} & 0 \\ 0 & I_2 \end{pmatrix} \text{ and } P = \begin{bmatrix} -\mathcal{L}_R & 0 \\ 0 & \Lambda \\ P_{21} & 0 \end{bmatrix} P_{21}^T$$

$$\text{with } \Lambda = \begin{pmatrix} \Lambda_0 & \dots & \Lambda_b \\ \vdots & 0 & 0 \\ \Lambda_b^T & 0 & 0 \end{pmatrix}; \quad \mathcal{L}_R = \Lambda \otimes \frac{R}{\chi}$$

$$P_{21} = \left( \begin{array}{c|c} \left( \begin{array}{c} \Xi_0 \\ \dots \\ \Xi_b \end{array} \right)^T - \left( \begin{array}{c} \Upsilon_0 \\ \dots \\ \Upsilon_b \end{array} \right)^T & \\ \hline \left( \begin{array}{c} \Upsilon_0 \dots \Upsilon_b \end{array} \right) + \left( \begin{array}{c} \Xi_0 \dots \Xi_b \end{array} \right) & 0 \end{array} \right)$$

The elements  $\Lambda_i$ ,  $\Xi_i$ ,  $\Upsilon_i$ ,  $L_i$  and  $K_i$  ( $i = 0 \dots b$ ) of the parametrization of  $P$  can take any values provided that:

$$\Upsilon_i = \begin{pmatrix} l_{i,1} & l_{i,2} \\ l_{i,2} & l_{i,3} \end{pmatrix}; \quad \Xi_i = \begin{pmatrix} 0 & \tilde{l}_{i,2} \\ -\tilde{l}_{i,2} & 0 \end{pmatrix}$$

$$L_i = \begin{pmatrix} L_{i,1} & L_{i,2} \\ L_{i,2} & L_{i,3} \end{pmatrix}; \quad K_i = \begin{pmatrix} 0 & K_{i,2} \\ -K_{i,2} & 0 \end{pmatrix}$$

with  $l_{i,j}$  and  $\tilde{l}_{i,j} \in \mathbf{R}^{1 \times k}$  and with  $K_{i,j} = -K_{i,j}^T \in \mathbf{R}^{k \times k}$  and  $L_{i,j} = -L_{i,j}^T \in \mathbf{R}^{k \times k}$ . Finally, the elements of the matrix  $\Lambda$  are constrained as follows:  $\Lambda_i \in \mathbf{R}^{2 \times 2}$  ( $i = 0 \dots b$ ),  $\Lambda_0 = \Lambda_0^T$  and there must exist a matrix  $X = X^T$  such that the following LMI is satisfied:

$$\begin{pmatrix} A_B^T X A_B - X & A_B^T X B_B \\ B_B^T X A_B & B_B^T X B_B \end{pmatrix} + \begin{pmatrix} C_B^T \\ D_B^T \end{pmatrix} \Lambda \begin{pmatrix} C_B & D_B \end{pmatrix} > 0 \quad (13)$$

with  $(A_B, B_B, C_B, D_B)$  a state-space realization of  $\mathcal{B}(z) \otimes I_2$ . In the sequel, we will denote by  $\mathcal{P}$  the class of matrices  $P$  having the structure given above.

**Remark 1** Different types of basis functions can be considered. Possible choices are orthonormal basis functions such as the FIR basis functions  $\mathcal{B}(z) = (1 \ z^{-1} \ \dots \ z^{-b})^T$  or the Laguerre basis functions.

In the sequel, we will show that solving (10) will require the determination of a matrix  $P$  having the structure in Proposition 1. The affine parametrization of  $P$  will make possible a solution via LMI-based optimization.

### 2.3 LMI formulation for the validation problem

Knowing that the squared  $H_2$  gain of a transfer function is equivalent to the energy of the pulse response of this transfer function, it is of interest to restrict the input of the LFT system (9) to signals  $v(t) = w\delta(t)$  (with  $w \triangleq [w_1 \ w_2]^T \in \mathbf{R}^{2 \times 1}$  and  $\delta(t)$  the discrete-time pulse signal). Considering now the signal  $q(t)$  of the LFT (9) and  $v(t) = w\delta(t)$  as inputs and using the transfer matrices  $M_{ij}(z)$  and  $\Psi(z)$  (see (9) and (12)), we define the following system (in the frequency domain):

$$\begin{bmatrix} z_1(e^{j\omega}) \\ z_2(e^{j\omega}) \end{bmatrix} = \begin{bmatrix} \Psi(e^{j\omega}) \begin{bmatrix} I_{2k} & 0 \\ M_{11}(e^{j\omega}) & M_{12}(e^{j\omega}) \end{bmatrix} \\ \begin{bmatrix} M_{21}(e^{j\omega}) & M_{22}(e^{j\omega}) \end{bmatrix} \end{bmatrix} \begin{bmatrix} q(e^{j\omega}) \\ \begin{bmatrix} w_1 \\ w_2 \end{bmatrix} \end{bmatrix} \quad (14)$$

The state-space representation of this new system is denoted:

$$x(t+1) = Ax(t) + B_1 q(t) + B_2 \begin{bmatrix} w_1 \delta(t) \\ w_2 \delta(t) \end{bmatrix}$$

$$\begin{bmatrix} z_1(t) \\ z_2(t) \end{bmatrix} = \begin{bmatrix} C_1 \\ C_2 \end{bmatrix} x(t) + \begin{bmatrix} D_{11} \\ D_{21} \end{bmatrix} q(t) + \begin{bmatrix} D_{12} \\ D_{22} \end{bmatrix} \begin{bmatrix} w_1 \delta(t) \\ w_2 \delta(t) \end{bmatrix} \quad (15)$$

We are now in position to present a method to compute an upper bound for the worst case performance  $J_{WC}$ . This is done in the following proposition whose proof is given in Appendix B.

**Proposition 2** Consider the validation problem (3) for the LFT (9) with an uncertainty  $\Theta$  such that (11) holds. Consider the class  $\mathcal{P}$  of matrices  $P$  having the structure given in Proposition 1. Finally, consider that Assumptions 1 and 2 hold. Then, the solution  $\gamma_{\text{opt}}$  of the following LMI optimization problem is an upper bound for the solution of (3):

$$\min_{\gamma, Q=Q^T, K=K^T, P \in \mathcal{P}} \gamma$$

s.t. Trace( $Q$ ) <  $\gamma$ , (16)

$$B_2^T K B_2 + \begin{bmatrix} D_{12} \\ D_{22} \end{bmatrix}^T \begin{bmatrix} P & 0 \\ 0 & 1 \end{bmatrix} \begin{bmatrix} D_{12} \\ D_{22} \end{bmatrix} < Q, \quad (17)$$

$$F_1(K) + F_2(P) < 0 \quad (18)$$

where

$$F_1(K) := \begin{bmatrix} I & 0 \\ A & B_1 \end{bmatrix}^T \begin{bmatrix} -K & 0 \\ 0 & K \end{bmatrix} \begin{bmatrix} I & 0 \\ A & B_1 \end{bmatrix} \quad (19)$$

$$F_2(P) := \begin{bmatrix} C_1 & D_{11} \\ C_2 & D_{21} \end{bmatrix}^T \begin{bmatrix} P & 0 \\ 0 & 1 \end{bmatrix} \begin{bmatrix} C_1 & D_{11} \\ C_2 & D_{21} \end{bmatrix} \quad (20)$$

The matrices in these LMIs are defined in (15). ■

In the LMI problem of Proposition 2, determining  $P \in \mathcal{P}$  consists of determining the different elements of the affine parametrization of  $P$  i.e. the actual decision variables are  $\Lambda_i, \Upsilon_i$ , etc (see Proposition 1). Note also that the LMI (13) has also to be taken into account. Proposition 2 holds for any uncertainty type provided this uncertainty has a multiplier  $\Pi(\omega)$  satisfying (12). As such, Proposition 2 is thus an adaptation towards discrete-time systems of the validation result for continuous-time system in [13]. Besides the intrinsic differences between discrete- and continuous-time systems, the main differences with [13] is that we have to carefully choose the LFT (9) (see Assumption 2) in order to prove the result (see Appendix B) and that we have to carefully deal with the fact that the matrices  $D_{12}$  and  $D_{22}$  can be nonzero with discrete-time systems. The latter adds an extra term in the LMI (17). As in [13], the result is only an upper bound of the solution of (3) because of the conservatism introduced by the fact that the implication in (11) is only in one direction and by the restriction of the frequency dependence in Proposition 1.

### 3 Robust $H_2$ filter design

In this section, we consider Problem 2 (see (4)) i.e. the robust filter design problem. The only difference from the performance validation problem is that, instead of considering  $F$  as a given transfer function, this filter is now also a decision variable.

In this paper, we will restrict attention to filters having a state-space representation  $(A_F, B_F, C_F, D_F)$  with prespecified matrices  $A_F$  and  $B_F$ . This covers, e.g., FIR filters, which are commonly used in Telecommunications applications where deconvolution filtering is often used, but also Laguerre and Kautz filters. Other filters having this property are filters with pre-specified denominator. Due to this restriction, the additional decision variables are the matrices  $C_F$  and  $D_F$  since those matrices contain the to-be-determined coefficients. We will now investigate how these matrices appear in (17), (18).

In order to be able to rewrite the matrix inequalities (17), (18) as functions of  $C_F$  and  $D_F$ , we need to derive a (minimal) state-space representation for the system (14). Indeed, the state-space matrices of this system appear in the considered matrix inequalities. The system (14) can be represented as in Figure 2 where  $p$  is the same as in (9) and where the dependence of (14)

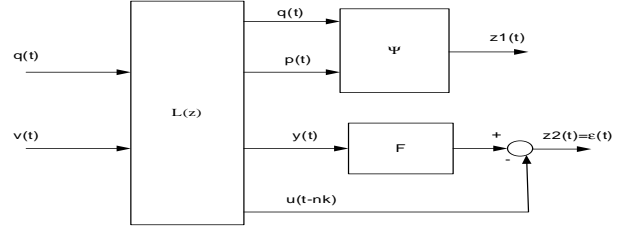

Fig. 2. Schematic of system (14).

on  $F$  is represented. The minimal state-space representation for the system (14) can be easily deduced from a minimal state-space representation for the transfer matrix  $L$  defined in Figure 2. Let us therefore suppose that we have a minimal realization for the transfer matrix  $L$ :

$$\begin{aligned} \bar{x}(t+1) &= \bar{A}\bar{x}(t) + \bar{B}_1q(t) + \bar{B}_2v(t) \\ \begin{bmatrix} q(t) \\ p(t) \\ y(t) \\ u(t-n_k) \end{bmatrix} &= \begin{bmatrix} \bar{C}_1 \\ \bar{C}_2 \\ \bar{C}_3 \end{bmatrix} x(t) + \begin{bmatrix} \bar{D}_{1q} \\ \bar{D}_{2q} \\ 0 \end{bmatrix} q(t) + \begin{bmatrix} 0 \\ \bar{D}_{2v} \\ \bar{D}_{3v} \end{bmatrix} v(t) \end{aligned}$$

Note that  $\bar{D}_{3v} \neq 0$  only when  $n_k = 0$ . Using now the formulae on page 34 of [17] and denoting by  $(A_\Psi, B_\Psi, C_\Psi, D_\Psi)$  a minimal state-space representation of  $\Psi(z)$ , the state-space matrices of a minimal realization of the system (14) are given by:

$$A = \begin{bmatrix} \bar{A} & 0 & 0 \\ B_\Psi \bar{C}_1 & A_\Psi & 0 \\ B_F \bar{C}_2 & 0 & A_F \end{bmatrix}, \quad B_1 = \begin{bmatrix} \bar{B}_1 \\ B_\Psi \bar{D}_{1q} \\ B_F \bar{D}_{2q} \end{bmatrix}, \quad B_2 = \begin{bmatrix} \bar{B}_2 \\ 0 \\ B_F \bar{D}_{2v} \end{bmatrix}$$

$$C_1 = [D_\Psi \bar{C}_1 \mid C_\Psi \mid 0], \quad C_2 = [D_F \bar{C}_2 - \bar{C}_3 \mid 0 \mid C_F]$$

and  $D_{11} = D_\Psi \bar{D}_{1q}$ ,  $D_{12} = 0$ ,  $D_{21} = D_F \bar{D}_{2q}$ ,  $D_{22} = D_F \bar{D}_{2v} - \bar{D}_{3v}$ . Consequently, we see that  $C_2$ ,  $D_{21}$  and  $D_{22}$  are the only matrices which are functions of  $C_F$  and  $D_F$  and that, furthermore, they are linear functions of  $C_F$  and  $D_F$ . Let us now consider the dependence on  $C_F$  and  $D_F$  of the matrix inequality (17) i.e.  $B_2^T K B_2 + D_{12}^T P D_{12} + D_{22}^T D_{22} < Q$ . Because of the product  $D_{22}^T D_{22}$ , such an expression is not an LMI in  $D_F$ . However, using the Schur complement, we see that this inequality is equivalent to:

$$\begin{bmatrix} Q - B_2^T K B_2 - D_{12}^T P D_{12} & D_{22}^T \\ D_{22} & 1 \end{bmatrix} > 0 \quad (21)$$

The latter expression is an LMI in  $Q, P, K$  but now also in  $D_F$ . Similarly (18) is equivalent to an LMI in  $Q, P, K, C_F$  and  $D_F$ :

$$\begin{bmatrix} -F_1(K) - [C_1 \ D_{11}]^T P [C_1 \ D_{11}] & [C_2 \ D_{21}]^T \\ [C_2 \ D_{21}] & 1 \end{bmatrix} > 0 \quad (22)$$

The robust filter design problem (4) now can be written

$$\begin{aligned} & \min_{\gamma, Q=Q^T, K=K^T, P \in \mathcal{P}, C_F, D_F} \gamma \\ & \text{s.t. (16), (21) and (22) hold} \end{aligned}$$

We denote this LMI-based optimization problem *ROBFILT* for future reference. The robust filter has then the state-space realization  $(A_F, B_F, C_F^{\text{opt}}, D_F^{\text{opt}})$  with  $C_F^{\text{opt}}$  and  $D_F^{\text{opt}}$  solutions of *ROBFILT* and  $A_F$  and  $B_F$  the prespecified matrices. Like Proposition 2, *ROBFILT* is an adaptation of continuous-time robust filtering results (see e.g. [13]) to the discrete-time case.

#### 4 Experiment design for robust $H_2$ filtering

Now let us turn to our third problem i.e the optimal experiment design problem (5). For this purpose, it is important to define clearly the relation between the power spectrum  $\Phi_{u_{id}}$  and the uncertainty region  $U$  obtained after an open-loop identification with  $N$  data ( $N$  is supposed given) and with an excitation signal  $u_{id}$  of power spectrum  $\Phi_{u_{id}}$  ( $\Phi_{u_{id}}$  will be the decision variable for experiment design). We will here use the following relation that was also used e.g. in [9, 2]:

$$U(\Phi_{u_{id}}) = \{ \theta \mid (\theta - \hat{\theta}_{init})^T R(\Phi_{u_{id}}) (\theta - \hat{\theta}_{init}) < \chi \}$$

$$R(\Phi_{u_{id}}) = \frac{N}{2\pi} \int_{-\pi}^{\pi} F_1(e^{j\omega}) F_1^*(e^{j\omega}) \Phi_{u_{id}}(\omega) + F_2(e^{j\omega}) F_2^*(e^{j\omega}) d\omega$$

where  $\hat{\theta}_{init}$  is a known initial estimate of the true system (e.g. obtained from an earlier identification experiment; note that, in the simulation example of next section, we will use the true parameter vector as initial estimate) and  $F_1 = H^{-1}(z, \hat{\theta}_{init}) \left. \frac{\partial G(z, \theta)}{\partial \theta} \right|_{\hat{\theta}_{init}}$  and  $F_2 = H^{-1}(z, \hat{\theta}_{init}) \left. \frac{\partial H(z, \theta)}{\partial \theta} \right|_{\hat{\theta}_{init}}$ . In this expression, we do not consider the random relation between  $\Phi_{u_{id}}$  and the to-be-identified parameter vector. Indeed, we pose the center of the ellipsoid equal to the a-priori estimate  $\hat{\theta}_{init}$ . Consequently, the only dependence of  $U$  on  $\Phi_{u_{id}}$  is via the matrix  $R$  which is equal to the inverse of the covariance matrix  $P_\theta$  of the to-be-identified parameter vector. The expression of  $R$  given above is the asymptotic expression of  $P_\theta^{-1}$  where  $\theta_0$  has been replaced by  $\hat{\theta}_{init}$  [11].

Note now that the expression for  $R$  is affine in  $\Phi_{u_{id}}(\omega)$  and that this matrix  $R$  only appears in  $P$  in the optimization problem *ROBFILT*. As shown in Proposition 1, the matrix  $P$  is bilinear in  $R$  and the matrix  $\Lambda$ . Thus if we modify *ROBFILT* by keeping  $\Lambda$  fixed and adding  $\Phi_{u_{id}}$  to the decision variables (and adding (7)), the modified problem is still an LMI. We denote this modified optimization problem *MODROBFILT* for future reference.

Consequently, in order to determine the optimal input spectrum  $\Phi_{u_{id}}$  for the identification, we can use an iterative algorithm. Each iteration of this algorithm is made of two steps. In a first step, for a fixed spectrum  $\Phi_{u_{id}}$  and thus a fixed  $R$ , we solve *ROBFILT*. This delivers a value for the decision variable  $\Lambda$ . In a second step, we solve *MODROBFILT* to optimize on  $\Phi_{u_{id}}$  by fixing  $\Lambda$  to the value found in the first step. This delivers a new value for  $\Phi_{u_{id}}$  that can be subsequently used in Step 1. This approach is inspired by the DK-approach in  $\mu$ -synthesis [17].

The spectrum  $\Phi_{u_{id}}$  will be generally parametrized as follows [9]:

$$\Phi_{u_{id}}(\omega) = \sum_{r=-M}^M \beta_r e^{j\omega r} > 0 \quad (23)$$

with  $M$  an user choice and  $\beta_r = \beta_{-r} \in \mathbf{R}$ . This corresponds to signals  $u_{id}$  obtained by filtering a white noise through a FIR filter of order  $M + 1$ . With this parametrization,  $R$  can be rewritten as an affine function of the coefficients  $\beta_r$  ( $r = 0 \dots M$ ) and the constraint (7) as  $\beta_0 < \alpha$  (see [9]). The coefficients  $\beta_r$  ( $r = 0 \dots M$ ) become so the actual decision variables of *MODROBFILT*. This choice for the parametrization of  $\Phi_{u_{id}}$  also ensures that  $R$  will remain strictly positive-definite. Note that the positivity of the spectrum  $\Phi_{u_{id}}$  can be easily ensured via an extra LMI on the coefficients  $\beta_r$  ( $r = 0 \dots M$ ) (see [9]).

**Remark 2** Note that  $\Phi_{u_{id}}$  does not influence the uncertainty of the parameters that only appear in  $H(z, \theta)$ . This uncertainty can only be influenced by the number of data used for the identification and, if this uncertainty is too large, the number  $N$  of data should be increased.

**Remark 3** Assumption 1 must be verified for the uncertainty region  $U$  deduced from the designed  $\Phi_{u_{id}}$ . This can be verified a-posteriori after each iteration or directly incorporated as an extra LMI constraint into *MODROBFILT* using e.g. the multiplier (with fixed  $\Lambda$ ) and the separation of graph theorem (see e.g. [14]).

#### 5 Numerical illustrations

We consider the following Box-Jenkins true system:  $y(t) = G_0(z)u(t) + H_0(z)e(t)$  with  $G_0(z) = \frac{b_0 z^{-1}}{1 + f_0 z^{-1}}$  and  $H_0(z) = 1 + c_0 z^{-1}$  with  $b_0 = 3.6$ ,  $c_0 = -0.9$  and  $f_0 = -0.7$ . Both  $G_0$  and  $H_0$  are represented in a Bode plot in Figure 3. The variance  $\sigma_e^2$  of the noise  $e(t)$  is here chosen equal to 1. We would like to reconstruct the signal  $u(t)$  of this system based on a measurement of the output  $y(t)$ . We will suppose that the to-be-reconstructed input is a white noise of variance 10000 i.e.  $\Phi_u(\omega) = 10000$  and  $W_u(z) = 100$  and that the delay  $n_k$  in Figure 1 is equal to one.

In order to determine a robust deconvolution filter  $F$  to reconstruct this input, we first identify a model and an uncertainty for the system using 1000 input-output data generated by a white noise of variance 1. To determine  $F$ , we will use *ROBFILT*. For this purpose, we need to fix some variables such as  $b$ ,  $\mathcal{B}(z)$  and  $n_f$ . The scalar  $b$  is the size of the basis function vector  $\mathcal{B}(z)$  which allows to factorize the multiplier  $\Pi(\omega)$ . It is to be noted that the larger  $b$ , the closer the optimal  $\gamma$  deduced with *ROBFILT* will be from the actual value of the worst case performance  $J_{WC}$  ( $\gamma$  is indeed an upper bound of  $J_{WC}$  and will be denoted  $J_{WC}^{up}$  in the sequel). On the other hand, the larger  $b$ , the larger the complexity of the optimization problem (see the expression of  $\Psi(z)$  in Proposition 1). As a trade-off choice, the value of  $b$  is here chosen equal to 2. We have also to choose which types of basis functions we will use in  $\mathcal{B}$ . Here, we have chosen Laguerre basis functions and we have chosen the pole  $\zeta$  of these Laguerre functions by trial and error as the one for which *ROBFILT* delivers the filter  $F$  with the smallest  $J_{WC}$ . For white noise, this is  $\zeta = e^{-3}$ . Finally, the scalar  $n_f$  is the order of the parametrization of the filter  $F(z)$  that will be here chosen as a FIR. A similar trade-off as for the value of  $b$  must be done for  $n_f$ : we have here chosen  $n_f = 3$ .

For  $\Phi_{u_{id}}(\omega) = 1 \forall \omega$ , the optimization problem *ROBFILT* delivers a filter  $F$  achieving an upper bound of the robust performance  $J_{WC}^{up} = 2.14$ . In order to have an idea of the conservatism, we compute a lower bound for  $J_{WC}$  by gridding  $U$ . The computed lower bound is here  $J_{WC}^{low} = 1.26$ . The conservatism could seem high, but these numbers have to be compared with the power of the to-be-reconstructed signal equal to 10000. This comparison shows that the conservatism is in fact limited.

We will now determine the spectrum  $\Phi_{u_{id}}$  of power  $\alpha = 1$  which minimizes the robust performance using the results of Section 4. For this purpose, we determine the parameters  $\alpha_r = \alpha_{-r}$  in the classical parametrization (23) where  $M$  is chosen equal to 30. The spectrum  $\Phi_{u_{id}}$  obtained after the first iteration is represented in black dashed in Figure 4 where it is compared to  $\Phi_{u_{id}}(\omega) = 1 \forall \omega$  (blue dashdot).

We continue to iterate between *ROBFILT* and *MODROBFILT*. After three iterations, we obtain the spectrum represented in red solid in Figure 4. This spectrum  $\Phi_{u_{id}}(\omega)$  delivers an uncertainty  $U$  for which  $J_{WC}^{up}$  is equal to 0.756 while  $J_{WC}^{low} = 0.43$ . With respect to the initial white spectrum, this is an improvement of 65% for both  $J_{WC}^{up}$  and  $J_{WC}^{low}$ . Additional iterations do not yield further improvement. Consequently, to reconstruct a white noise signal  $u(t)$ , an identification with a white noise excitation  $u_{id}(t)$  is far from optimal. The optimal excitation signal is a signal that concentrates

its power<sup>1</sup> around the frequency 0.15 as can be seen in Figure 4. Using such a signal instead of white noise indeed reduces the guaranteed performance of the designed filter by 65%. Such an improvement can also be explained by observing the reduction in volume of the uncertainty ellipses obtained when you use the optimal excitation signal instead of a white noise signal (see Figure 5 where we represent those ellipses centered at 0 for comparison purposes and where we restrict attention to the parameters  $b$ ,  $f$  in the  $G$ -transfer function). It is to be noted that the optimal spectrum concentrates its power in the region of the pole of  $G_0$  (located at  $\omega = 0.35$ ) and of the zero of  $H_0$  (located at  $\omega = 0.1$ ).

The optimal filter  $F(z)$  corresponding to this third iteration is represented in Figure 3 where we can observe that  $|F(e^{j\omega})| \approx |G_0(e^{j\omega})|^{-1}$ . It is to be noted that the optimal filter does not change significantly when going from a white noise excitation signal to the optimal excitation signal.

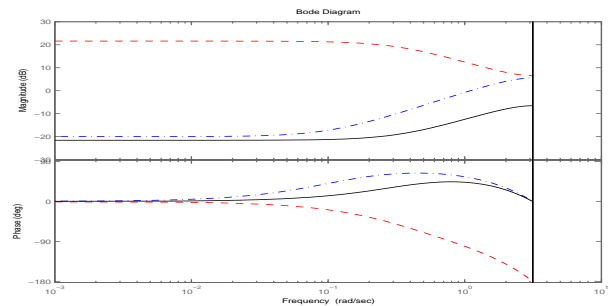

Fig. 3. Bode plot of  $G_0$  (red dashed), of  $H_0$  (blue dashdot) and of the optimal filter  $F$  obtained after three iterations (black solid)

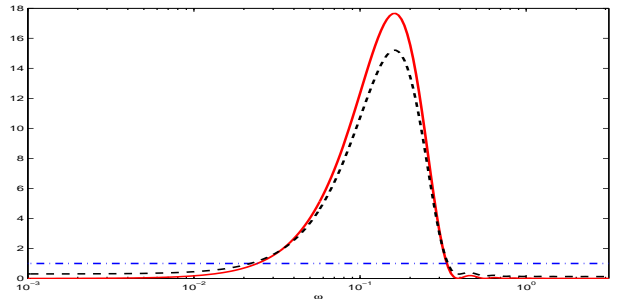

Fig. 4. White noise spectrum  $\Phi_{u_{id}}(\omega) = 1$  (blue dashdot), Spectrum  $\Phi_{u_{id}}(\omega)$  obtained after one iteration (black dashed),  $\Phi_{u_{id}}(\omega)$  obtained after three iterations (red solid)

## 6 Conclusions

In this contribution we have addressed the problem of robust deconvolution for ellipsoidal parametric uncertainty. In addition, we have taken the further step of

<sup>1</sup> A sinusoid of power 1 and frequency 0.15 would even deliver slightly better results:  $J_{WC}^{up} = 0.71$  and  $J_{WC}^{low} = 0.41$ .



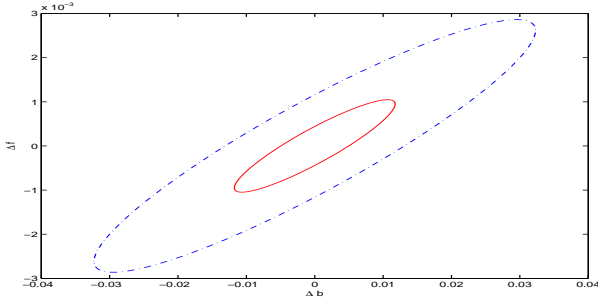

Fig. 5. Uncertainty ellipses when  $\Phi_{u_{id}}(\omega) = 1$  (blue dashdot) and when  $\Phi_{u_{id}}(\omega)$  is the optimal spectrum obtained after three iterations (red solid)

considering the problem of how to design the input in an identification experiment such that the resulting robust filter gives the smallest possible worst-case  $H_2$  performance in the set of uncertain systems. We believe these methods to have wide applicability. As an example, these results allow with minor adaptations to compute the worst case  $H_2$  performance achieved by a controller over an uncertainty set delivered by system identification. This is an extension of the results in [7] considering  $H_\infty$  performance.

## 7 Acknowledgment

The authors gratefully acknowledge fruitful discussions with H. Koroglu, C. Scherer, M. Barenthin and C. Rojas.

## References

- [1] M. Barenthin, X. Bombois, H. Hjalmarsson, and G. Scorletti. Identification for control of multivariable systems: controller validation and experiment design via LMIs. *Automatica*, 44(12):3070–3078, 2008.
- [2] X. Bombois, G. Scorletti, M. Gevers, P.M.J. Van den Hof, and R. Hildebrand. Least costly identification experiment for control. *Automatica*, 42(10):1651–1662, 2006.
- [3] S. Boyd, L. El Ghaoui, E. Feron, and V. Balakrishnan. *Linear Matrix Inequalities in Systems and Control Theory*, volume 15 of *Studies in Appl. Math.* SIAM, Philadelphia, June 1994.
- [4] Y.L. Chen and B.S. Chen. Minimax robust deconvolution filters under stochastic parametric and noise uncertainties. *IEEE Transactions on Signal Processing*, 42(1):32–45, 1994.
- [5] Y.C. Eldar. Robust mean-squared error estimation in the presence of model uncertainties. *IEEE Transactions on Signal Processing*, 53(1):168–181, 2005.
- [6] J.C. Geromel and M.C. de Oliveira.  $H_2$  and  $H_{inf}$  robust filtering for convex bounded uncertain systems. *IEEE Transactions on Automatic Control*, 46(1):100–107, 2001.

- [7] M. Gevers, X. Bombois, B. Codrons, G. Scorletti, and B.D.O. Anderson. Model validation for control and controller validation in a prediction error identification framework- part I: Theory. *Automatica*, 39(3):403–415, 2003.
- [8] D.N. Godard. Self-recovering equalization and carrier tracking in two-dimensional data communication-systems. *IEEE Transactions on Communications*, 28(11):1867–1875, 1980.
- [9] H. Jansson and H. Hjalmarsson. Input design via LMIs admitting frequency-wise model specifications in confidence regions. *IEEE Transactions on Automatic Control*, 50(10):1534–1549, October 2005.
- [10] Y. Liu, T.F. Wong, and W.W. Hager. Training signal design for estimation of correlated MIMO channels with colored interference. *IEEE Transactions on Signal Processing*, 55(4):1486–1497, 2007.
- [11] L. Ljung. *System Identification: Theory for the User*. Prentice-Hall, Englewood Cliffs, NJ, 2nd edition, 1999.
- [12] J.M. Mendel. *Optimal Seismic Deconvolution*. New York Academic, 1983.
- [13] C. Scherer and I.E. Kose. Robustness with dynamic IQCs: an exact state-space characterization of nominal stability with applications to robust estimation. *Automatica*, 44:1666–1675, 2008.
- [14] G. Scorletti. Robustness analysis with time delays. In *Proc. 36th IEEE Conference on Decision and Control*, San Diego, 1997.
- [15] K. Sun and A. Packard. Robust  $H_2$  and  $H_{inf}$  filters for uncertain LFT systems. *IEEE Transactions on Automatic Control*, 50(5):715–720, 2005.
- [16] J. Veenman, H. Koroglu, and C.W. Scherer. An IQC approach to robust estimation against perturbations of smoothly time-varying parameters. In *CD-ROM Proc. 47th Conference on Decision and Control*, pp. 2533–2538, Cancun, Mexico, 2008.
- [17] K. Zhou and J. Doyle. *Essentials of Robust Control*. Prentice Hall, Upper Saddle River, New Jersey, 1998.

## A Proof of Proposition 1

In[1], a very general parametrization of the multiplier  $\Pi(\omega)$  satisfying (11) is proposed:

$$\Pi(\omega) = \left[ \begin{array}{c|c} -Z_0 \otimes \frac{R}{x} + \begin{bmatrix} j A_{11} & B_{12} + j A_{12} \\ -B_{12} + j A_{12} & j A_{22} \end{bmatrix} & * \\ \hline \begin{bmatrix} j p_{11} & \tilde{p}_{12} + j p_{12} \\ -\tilde{p}_{12} + j p_{12} & j p_{22} \end{bmatrix} & Z_0 \end{array} \right]$$

where  $R$  is the matrix defining  $U$  (see (2)). The other elements in this parametrization are frequency-dependent and can take any values provided that  $p_{ij}(\omega)$ ,  $\tilde{p}_{ij}(\omega) \in \mathbf{R}^{1 \times k}$ ,  $Z_0(\omega)$  a positive definite Hermitian matrix of dimension 2 and  $A_{ij}(\omega)$   $B_{ij}(\omega) \in \mathbf{R}^{k \times k}$  with  $A_{ij} = -A_{ij}^T$  and  $B_{ij} = -B_{ij}^T$ .

Consequently, we must prove that the factorization of Proposition 1 is a factorization of the above  $\Pi(\omega)$ . It is indeed the case. The frequency function  $Z_0(\omega)$  in  $\Pi(\omega)$  is factorized as  $Z_0(\omega) = (\mathcal{B}^* \otimes I_2)\Lambda(\mathcal{B} \otimes I_2)$  which is Hermitian and which is guaranteed to be positive definite by the existence of  $X = X^T$  such that (13) holds. The latter is a consequence of the Kalman Yakubovitch Popov (KYP) Lemma [3]. Similarly, the other frequency functions are factorized as follows:  $Z_0(\omega) \otimes \frac{R}{X} = (\mathcal{B}^* \otimes I_{2k})\mathcal{L}_R(\mathcal{B} \otimes I_{2k})$ ,

$$\begin{pmatrix} j p_{11} & j p_{12} \\ +j p_{12} & j p_{22} \end{pmatrix} = (\Upsilon_0 \dots \Upsilon_b) (\mathcal{B} \otimes I_{2k}) - (\mathcal{B}^* \otimes I_2) \begin{pmatrix} \Upsilon_0 \\ \dots \\ \Upsilon_b \end{pmatrix}$$

The factorization of  $\begin{pmatrix} j A_{11} & j A_{12} \\ j A_{12} & j A_{22} \end{pmatrix}$  is as above with  $\Upsilon_i$  replaced by  $L_i$  ( $i = 0 \dots b$ ). We have also:

$$\begin{pmatrix} 0 & \tilde{p}_{12} \\ -\tilde{p}_{12} & 0 \end{pmatrix} = (\Xi_0 \dots \Xi_b) (\mathcal{B} \otimes I_{2k}) + (\mathcal{B}^* \otimes I_2) \begin{pmatrix} \Xi_0 \\ \dots \\ \Xi_b \end{pmatrix}$$

Finally, the factorization of  $\begin{pmatrix} 0 & B_{12} \\ -B_{12} & 0 \end{pmatrix}$  is as above but with  $\Xi_i$  replaced by  $K_i$  ( $i = 0 \dots b$ ). All these factorizations lead to the desired properties for the elements of  $\Pi(\omega)$ . ■

## B Proof of Proposition 2

The first part of the proof consists of establishing that the LMIs (17) and (18) for some  $Q = Q^T$  implies that the system (15) has the following property:

$$\sum_{t=0}^{+\infty} \begin{pmatrix} z_1(t) \\ z_2(t) \end{pmatrix}^T \begin{bmatrix} P & 0 \\ 0 & 1 \end{bmatrix} \begin{pmatrix} z_1(t) \\ z_2(t) \end{pmatrix} < w^T Q w \quad (\text{B.1})$$

for any trajectory of the system. To show this, we first observe that, due to Assumption 2, the system (9), from which (15) is deduced, has the property that  $q(t=0) = 0$  when the input vector  $v(t)$  is such that  $v(t < 0) = 0$ . Consequently, since here  $v(t) = w\delta(t)$ , the state-space representation (15) for  $t > 0$  can be simplified to

$$\begin{aligned} x(t+1) &= Ax(t) + B_1 q(t) \\ \begin{bmatrix} z_1(t) \\ z_2(t) \end{bmatrix} &= \begin{bmatrix} C_1 \\ C_2 \end{bmatrix} x(t) + \begin{bmatrix} D_{11} \\ D_{21} \end{bmatrix} q(t) \end{aligned} \quad (\text{B.2})$$

if we impose the following initial conditions:  $x(1) = B_2 w$  and  $\begin{pmatrix} z_1(0) \\ z_2(0) \end{pmatrix} = \begin{pmatrix} D_{12} \\ D_{22} \end{pmatrix} w$

The LMI (18) ensures that, for any trajectory of the system (B.2),

$$\begin{aligned} &\begin{bmatrix} x(t) \\ q(t) \end{bmatrix}^T (F_1(K) + F_2(P)) \begin{bmatrix} x(t) \\ q(t) \end{bmatrix} < 0 \\ \iff &x(t+1)^T K x(t+1) - x(t)^T K x(t) + \dots \\ &\dots + \begin{bmatrix} z_1(t) \\ z_2(t) \end{bmatrix}^T \begin{bmatrix} P & 0 \\ 0 & 1 \end{bmatrix} \begin{bmatrix} z_1(t) \\ z_2(t) \end{bmatrix} < 0 \end{aligned}$$

The latter constraint is of the form  $g(t) < 0$  and holds for each time  $t > 0$ . Consequently, it implies that  $\sum_{t=1}^{+\infty} g(t) < 0$  and thus,  $A$  being stable, that

$$\sum_{t=1}^{+\infty} \begin{pmatrix} z_1(t) \\ z_2(t) \end{pmatrix}^T \begin{bmatrix} P & 0 \\ 0 & 1 \end{bmatrix} \begin{pmatrix} z_1(t) \\ z_2(t) \end{pmatrix} < x(1)^T K x(1) \quad (\text{B.3})$$

The first LMI (17) ensures that, for any trajectory of the system (B.2),

$$\begin{aligned} &w^T \left( B_2^T K B_2 + \begin{pmatrix} D_{12} \\ D_{22} \end{pmatrix}^T \begin{bmatrix} P & 0 \\ 0 & 1 \end{bmatrix} \begin{pmatrix} D_{12} \\ D_{22} \end{pmatrix} \right) w < w^T Q w \\ \iff &x(1)^T K x(1) < w^T Q w - w^T \begin{pmatrix} D_{12} \\ D_{22} \end{pmatrix}^T \begin{bmatrix} P & 0 \\ 0 & 1 \end{bmatrix} \begin{pmatrix} D_{12} \\ D_{22} \end{pmatrix} w \end{aligned}$$

Combining (B.3) and the last expression, we obtain (B.1).

For the second part of the proof, we can follow the reasoning in e.g. [13, 16]. Indeed, it is very easy to show using (9), (12), (14) and Parseval's theorem that the property (B.1) is equivalent to the property:

$$\begin{aligned} &\frac{1}{2\pi} \int_{-\pi}^{\pi} \begin{bmatrix} q(e^{j\omega}) \\ p(e^{j\omega}) \end{bmatrix}^* \Pi(\omega) \begin{bmatrix} q(e^{j\omega}) \\ p(e^{j\omega}) \end{bmatrix} d\omega + \\ &\epsilon(e^{j\omega})^* \epsilon(e^{j\omega}) d\omega < w^T Q w \end{aligned} \quad (\text{B.4})$$

for any trajectory of (14) (note that Assumption 1 ensures that Parseval's theorem can be used). Introducing the relation  $p = \Theta q$  of the LFT (9) which is the original system with which (14) is defined, we see that the property (B.4) for any trajectory of (14) is equivalent to the property:

$$\begin{aligned} &\frac{1}{2\pi} \int_{-\pi}^{\pi} p^*(e^{j\omega}) \begin{bmatrix} \Theta \\ I_2 \end{bmatrix}^T \Pi(\omega) \begin{bmatrix} \Theta \\ I_2 \end{bmatrix} p(e^{j\omega}) d\omega + \\ &\epsilon(e^{j\omega})^* \epsilon(e^{j\omega}) d\omega < w^T Q w \end{aligned}$$

for any trajectory of the LFT (9) when  $v(t) = w\delta(t)$ . Now using (11), we see that the latter implies that, for all  $\theta \in U$ ,  $\frac{1}{2\pi} \int_{-\pi}^{\pi} \epsilon(e^{j\omega})^* \epsilon(e^{j\omega}) d\omega < w^T Q w$  which, combined to (16) for some  $Q = Q^T$ , yields  $\|\mathcal{F}(M(z), \Theta)\|_2^2 < \gamma$  for all  $\theta \in U$ .