



HAL
open science

Unified Representation of Fixtures: clamping, locating and supporting elements in CNC manufacture

Parag Vichare, Aydin Nassehi, Stephen Newman

► To cite this version:

Parag Vichare, Aydin Nassehi, Stephen Newman. Unified Representation of Fixtures: clamping, locating and supporting elements in CNC manufacture. *International Journal of Production Research*, 2010, pp.1. 10.1080/00207543.2010.518992 . hal-00638144

HAL Id: hal-00638144

<https://hal.science/hal-00638144>

Submitted on 4 Nov 2011

HAL is a multi-disciplinary open access archive for the deposit and dissemination of scientific research documents, whether they are published or not. The documents may come from teaching and research institutions in France or abroad, or from public or private research centers.

L'archive ouverte pluridisciplinaire **HAL**, est destinée au dépôt et à la diffusion de documents scientifiques de niveau recherche, publiés ou non, émanant des établissements d'enseignement et de recherche français ou étrangers, des laboratoires publics ou privés.



Unified Representation of Fixtures: clamping, locating and supporting elements in CNC manufacture

Journal:	<i>International Journal of Production Research</i>
Manuscript ID:	TPRS-2010-IJPR-0313.R1
Manuscript Type:	Original Manuscript
Date Submitted by the Author:	31-Jul-2010
Complete List of Authors:	Vichare, Parag; University of Bath, Mechanical Engineering Nassehi, Aydin; University of Bath, Mechanical Engineering; University of Bath, Department of Mechanical Engineering Newman, Stephen; University of Bath, Mechanical Engineering
Keywords:	FIXTURE DESIGN, INFORMATION SYSTEMS, CNC, MANUFACTURING SYSTEMS
Keywords (user):	STEP-NC, Resource Modelling

SCHOLARONE™
Manuscripts

Unified representation of fixtures: clamping, locating and supporting elements in CNC manufacture

Parag Vichare*, Aydin Nassehi, Stephen T. Newman

Department of Mechanical Engineering, University of Bath, Bath, BA2 7AY, UK

* Corresponding author. Email: P.Vichare@bath.ac.uk

(Received 31 March 2010)

A CNC machining operation is the outcome of the application of the integrated capabilities of various resources within the CNC machining centre. Part fixtures, clamping and other location mechanisms are essential subsets of CNC machining resources. Today, various fixturing techniques and attachments available on the market allow manufacturers to enhance their production capability without buying expensive machine tools. This technology rich fixturing domain is detached while representing and exchanging machine tool resource information for making manufacturing decisions. The research work in this paper utilizes the STEP-NC compliant Unified Manufacturing Resource Model (UMRM) for representing fixtures in conjunction with the parent CNC machining centre. Thus UMRM is enhanced in this context to represent various fixtures such as universal vises, chucks, pallets, auxiliary rotary tables among others. The major contribution of this paper is the application of the extension of the UMRM approach for representing fixturing domain, which allows generic modelling of fixtures and loading devices in addition to machine workpiece and process modelling. This would enable the stage of automated process planning and manufacturing. The universal approach in representing resource information allows the data to be utilised for making a wide variety of manufacturing decisions.

Keywords: fixture design; CNC; information model; resource modelling; STEP-NC; manufacturing systems

1. Introduction

Today, fixturing techniques allow manufacturers to increase their machining capability by holding the workpiece in orientations that are not possible with the base machine tool. Thus, the significant cost of buying expensive machine tools can be saved. In addition, the modularity and the consequential reconfigurability of these fixtures allow reuse of the manufacturing resources. These modular fixtures are considered as a major enabler for realising reconfigurable CNC manufacturing systems (Bi *et al.* 2008). As a part of CNC manufacturing system resources, fixtures have significant role in the production time and cost (Liqing and Kumar 2005, Pehlivan and Summers 2008).

1
2
3 Manufacturing information is one of the key factors and intensively researched
4 domains in establishing a link among various isolated CNC manufacturing systems
5
6 (Newman and Nassehi 2006) such as CAD, CAM, CNC etc. The fixtures are part of
7
8 these isolated systems and their integration is of utmost importance for CNC
9
10 manufacture. Traditionally manufacturing information representation has always
11
12 focused on products with information relating to their design, geometry and required
13
14 processes. However there is no standardized information model available to represent
15
16 the equipment used to manufacture such products. This equipment includes fixtures
17
18 which constitutes significant investment in setting up a CNC manufacturing facility
19
20 and is considered as a major asset of the business.
21
22
23
24
25
26

27 The representation of the various fixturing elements of the CNC machining
28
29 system resources is vital for making efficient and economic manufacturing decisions
30
31 (Pehlivan and Summers 2008). Making knowledgeable decisions is dependent on the
32
33 information related to manufacturing resources. The same provides the basis for
34
35 manufacturing activities including process planning, resource allocation, and facility
36
37 design (Bouti and Ait Kadi 1998). This basis is also essential for creating an
38
39 integrated, exchangeable and data sharing manufacturing information environment for
40
41 collaboration between multiple, globally dispersed organizations (Zhao *et al.* 1999).
42
43
44
45

46 Any state of the art CAx system can model various CNC machining system
47
48 resources and stores information regarding machine tools, kinematics, configuration,
49
50 cutting tools, workpieces and corresponding manufacturing process. However, very
51
52 few of these systems regard fixture specific information as machining system resource
53
54 information. These CAx systems can model geometric information of the fixturing
55
56 elements, but preserving the context or purpose of these fixturing elements in the
57
58 machining system has been underdeveloped. For example, the CAD modeller of any
59
60

1
2
3 CAx system can model the indexing pallet or workpiece/ tool changing arm.
4

5 However, only geometric shape of such mechanical elements is stored in the system.
6

7
8 There is no formal way of preserving the purpose (clamping, location, supporting) and
9
10 configuration (clamping ranges etc) of such elements in the CAx system. The possible
11
12 reason behind this limitation could be a vast variety in the fixturing resources and
13
14 implementation techniques.
15

16
17 In addition, general purpose fixturing elements such as vises, clamps, modular
18
19 jaws etc. available on the market are standardised in design. Thus, its use in
20
21 component manufacture does not require any expert planning system. However,
22
23 customised fixtures found in automobile and aerospace industries are more complex
24
25 and designed with a variety of objectives. This design consists of a set of
26
27 reconfigurable locating, clamping and supporting features, which are required to be
28
29 known for changes in design, progression in work, changes in product etc. This
30
31 requires a data model which can represent information regarding fixturing setup for
32
33 developing an expert fixture design system.
34
35
36
37

38
39 For example, in the case of process planning with the aid of CAx systems, the
40
41 manufacturing engineer has to model the fixture assembly. Various details such as
42
43 clamping and location units have to be modelled for generating a collision free tool
44
45 path. A manufacturing engineer's knowledge and experience is vital for planning such
46
47 a fixturing setup. Generating a resource specific tool path is the next step which is
48
49 well-automated using available CAM systems on the market. However, the machining
50
51 setup for a different job, using the same fixturing resources requires the engineer's
52
53 intervention. This is due to the fact that the configuration and capability information
54
55 of these fixturing elements have not been modelled. In addition, exchanging fixture
56
57
58
59
60

1
2
3 specific information in the computing environment for the integrated product and
4
5 process design is difficult due to a lack of standard constructs.
6
7

9 **2. Fixturing elements in the CNC manufacture**

10
11
12 Various fixture elements can be classified into standard type equipments such as
13
14 vises, clamps etc and modular type fixturing elements where each element serves as a
15
16 locator, supporter or clamp. Figure 1 illustrates these modular fixture elements as well
17
18 as standard fixturing equipment. The final fixturing setup shown in the Figure 1 is a
19
20 combination of modular elements and standard fixturing. Dai *et al.* (1997) started
21
22 classifying various modular fixture elements for establishing a database for
23
24 developing computer aided fixture design and assembly. The modular fixturing
25
26 elements were classified according to their functions: (a) base plate elements, where
27
28 all the locating, supporting and clamping elements and workpiece can be mounted; (b)
29
30 locating elements, such as location pins, V-blocks, location pads etc; (c) supporting
31
32 elements such as adjustable spacers, shims etc for supporting workpiece; and (d)
33
34 clamping elements, used for clamping the workpiece. A set of fixturing elements can
35
36 be assembled together for locating, supporting or clamping the workpiece on the
37
38 machine table as shown in fixture setup pane in Figure 1. These subassemblies of
39
40 modular fixture are entitled fixture towers (Dai *et al.* 1997). Another example of such
41
42 fixture blocks can be found in the pallet system where multiple workpieces are
43
44 clamped on a single pallet. This type of fixturing is more prevalent in the flexible
45
46 manufacturing systems (FMS) due to its reconfigurable nature.
47
48
49
50
51
52
53
54

55
56 Customised fixturing equipment such as strap clamps, vises, drilling jigs are
57
58 the subassemblies designed for a specific purpose. An individual item may consist of
59
60 various modular fixture subassemblies along with dedicated fixturing elements suited

1
2
3 for the specific **workpiece geometry, for example**, the travelling column horizontal
4 machining centre linked to pallet pool system used for cylinder head machining. The
5
6 locating and clamping elements for these cylinder heads are customised according to
7
8 the geometric and machine-ability requirements. Generally this type of fixturing can
9
10 be found in the mass manufacturing scenarios where the production line is dedicated
11
12 to machining a single product. In such cases, automatic fixture design is reported as a
13
14 difficult task because fixture design is based on in-process, semi-finished workpiece
15
16 geometry; which again depends on the available manufacturing resources (Liqing and
17
18 Kumar 2005).
19
20
21
22
23
24
25
26

27 Figure 1. Use of modular and customised fixturing elements in the CNC machining
28 operation
29

30 **3. Fixture information modelling approaches**

31
32
33

34 **Fixturing is the mechanism that can be** used for executing various functions such as
35
36 locating, supporting and clamping. These mechanisms consist of various kinematic
37
38 joints to perform required functions. A data model for representing manufacturing
39
40 resources (Molina and Bell 2002) must be versatile enough to represent these
41
42 kinematic links between machine elements. These kinematic joints are also a part of
43
44 machine tool configuration; by virtue of which various tool and workpiece axis
45
46 movements are achieved on the CNC machining centre. Hence, it is very important to
47
48 have a common methodology (Cecil 2001) to represent the numerous configurations
49
50 of CNC machine tools equipped with various fixturing elements in order to provide a
51
52 complete representation of the CNC machining system.
53
54
55
56

57
58 The key problem of structuring the information models to support the
59
60 interactions between fixture design, process planning and product design was reported

1
2
3 by Bugtai and Young (1998). The issues related to the data structures required for
4
5 verifying manufacturing knowledge were discussed and standard based framework
6
7 were proposed by Cochrane *et al.* (2009). Mervyn, *et al.* (2006) developed an
8
9 information model describing fixture design knowledge and specification to improve
10
11 the product quality and reduce product lead-time. Yao, *et al.* (2005) divided automatic
12
13 setup planning into two sub-tasks: setup planning in part level and in station level in
14
15 which fixtures and machine tools were selected to machine several parts sequentially
16
17 on machine tools. Kow *et al.* (2000) described a CAD based methodology for
18
19 developing a tool collision free modular fixture design system using the Unigraphics
20
21 (UG) solid modeller, integrated with a modular fixture element database, based on a
22
23 hole-based IMAO modular fixturing system. Liqing and Kumar (2005) and
24
25 Padmanaban and Prabhakaran (2008) developed a **case-based solution** for design
26
27 problems in the complex fixturing domain on the idea that past problem solving
28
29 knowledge can be utilised in solving new problems. These approaches are well-
30
31 exploited in representing a specific manufacturing resource fixturing domain.
32
33 However, there has been no generic methodology for representing the enormous
34
35 diversity in machine tool configurations and auxiliary devices along with fixturing
36
37 domain. The commercial tools available are either machine vendor specific or limited
38
39 in their scope to represent some specific machine tool resource elements; resulting in
40
41 a plethora of representation methods which are bespoke and incomplete in terms of
42
43 representing the entire system's resources.
44
45
46
47
48
49
50
51

52
53 A range of kinematic joints can be represented with STEP's integrated
54
55 application resources (IR) (ISO 10303-105 1996). This IR specifies an information
56
57 model for the kinematic aspects of the mechanical product. It also describes a
58
59 methodology for representing kinematic structures. A fundamental procedure of this
60

1
2
3 methodology to represent a mechanism associates all kinematic joints to the
4
5 mechanism's coordinate system as shown in the Figure 2. The coordinate systems are
6
7 called frames in this part of STEP. For the purpose of representing the kinematic
8
9 aspect of a mechanism, a machine element is placed by the location and orientation of
10
11 the associated kinematic pairs with respect to mechanism's coordinate system (ISO
12
13 10303-105 1996, Rachuri *et al.* 2005).
14
15

16
17 This methodology is capable of representing tree kinematic structures and
18
19 close loop kinematic structures (Kjellberg *et al.* 2009). The objective of developing
20
21 this STEP's IR was to establish a neutral file format for exchanging kinematic
22
23 configuration information between CAx systems. However, its use for representing
24
25 integrated shop floor resources is debatable. For example, it can represent machine
26
27 tool structures, fixturing mechanisms, material handling systems. However, this IR
28
29 does not specify any methodology to integrate these discrete manufacturing resources.
30
31 In addition, it has not been utilised for constructing kinematic pairs by mapping
32
33 assembly features.
34
35
36
37
38
39

40 Figure 2. Machine tool configuration and corresponding kinematic representation
41 using STEP's IR 105 (ISO 10303-105 1996)
42
43

44 Vichare *et al.* (2009b) proposed a unified resource information modelling
45
46 approach called Unified Manufacturing Data Model (UMRM) for representing
47
48 information regarding a variety of manufacturing resources in decision making
49
50 process. The UMRM has been utilized to represent various configurations of
51
52 conventional CNC machine tools. It has been verified for modelling various
53
54 configurations (at least 256 configurations) of the 5 axis vertical machining centres
55
56 reported by Sato (Sato 2006). It has been utilised for representing various Turning
57
58 centres and multitasking turn-mill centres (Vichare *et al.* 2009b) along with various
59
60

1
2
3 auxiliary devices and material handling system configurations prevalent in the
4 manufacturing industry (Vichare *et al.* 2009a). In addition, UMRM has also been
5 exploited for verifying the fitness of the available manufacturing resources against
6 STEP-NC (ISO 14649-1 2002) compliant process plans (Nassehi and Vichare 2008).
7
8
9

10
11
12 Figure 3 depicts the reach of UMRM in representing manufacturing resource
13 domains. The scope of the last version of the UMRM (Nassehi and Vichare 2009) was
14 limited to representing machine tool axes movements required for the postprocessor
15 development. However, looking at the growing application of the modular fixtures,
16 reconfigurable setups this research work extends the scope of UMRM for representing
17 various kinematic aspects of the fixturing system by exploiting rich information
18 constructs of ISO 10303-105 (ISO 10303-105 1996).
19
20
21
22
23
24
25
26
27
28
29

30 **4. An Information model**

31 **4.1. Fixturing setup: A type of manufacturing resource**

32
33
34
35
36 A machine tool is an assembly of a various mechanical elements intended to convert a
37 workpiece into the finished product. Thus fixturing domain, as a part of
38 manufacturing resource is considered as an assembly of mechanical machine elements
39 with different kinematic joints to facilitate constrained movements. Figure 3
40 illustrates entity “manufacturing_resources”. This entity has been exploited for
41 representing various CNC machining system resource such as machine tools (Vichare
42 *et al.* 2009b), material handling systems etc (Vichare *et al.* 2009a). However, fixture
43 specific information in the CNC manufacture environment is as important as other
44 manufacturing resources. Thus, fixture specific information has been represented in
45 this paper by escalating the scope of UMRM through an entity “fixturing_setup”
46 shown in the Figure 3. EXPRESS-G diagram illustrates this entity as a type of
47
48
49
50
51
52
53
54
55
56
57
58
59
60

1
2
3 mechanical resource, which uses a kinematic joint to be able to connect it with the
4
5 parent machine tool.
6
7

8
9
10 Figure 3. EXPRESS-G representation of UMRM entity “manufacturing_resource” for
11 representing fixturing setup
12

13 14 15 **4.2. Representation of kinematic joint information for describing fixturing setup** 16

17
18
19 The kinematic aspects between two fixture elements or between fixture and the
20 machine tool can be rendered with the attributes of the entity “kinematic_joint”. This
21 entity inherits various kinematic pairs described in ISO 10303-105 (ISO 10303-105
22 1996) and has illustrated in the Figure 4. Each kinematic pair has distinct properties,
23 by virtue of which kinematic movements in the fixture assembly can be presented.
24
25 Entity “kinematic_joint” may have some axes of movement attached to it. Attaching
26 individual axis to kinematic joint represents their degrees of freedom. The entity, axis
27 has two subtypes: “linear_axis” and “rotary_axis”. When several axes are attached to
28 the kinematic joint, it represents a mechanical machine element (of the fixture
29 assembly) capable of moving in different directions. The kinematic linkage between a
30 kinematic joint and the machine element can be represented with the attribute
31 “kinematic_link”. Thus, a kinematic joint can be attached to the set of machine
32 elements using this attribute. It has a unique identifier and distinct transfer placements
33 for referencing it from the previous machine element’s kinematic joints. Thus, every
34 kind of manufacturing resource has a kinematic joint; and every kinematic joint is
35 connected to the mechanical machine element.
36
37
38
39
40
41
42
43
44
45
46
47
48
49
50
51
52
53
54
55
56
57
58
59
60

Figure 4. EXPRESS-G representation of UMRM entity “kinematic_joint”

4.3. Representation of fixturing configuration information

Every mechanical machine element modelled using UMRM has a capability of representing information regarding the fixturing configuration to be able to assemble it with another machine element. For example, a typical machine tool table is a mechanical machine element, which has T-slots for accommodating other fixtures. Thus, T-slots can be represented by exploiting various attributes of the entity “fixturing_config”. This entity (Figure 5) is abstracting various types of fixturing configurations that could be available on the mechanical machine element and can represent placement and pattern information of the fixturing feature by using entity “placement_pattern”. Thus, it is possible to construct a kinematic joint by mapping various fixturing features as shown in Figure 6.

Figure 5. EXPRESS-G representation of the UMRM entities “mechanical_machine_element” and “fixturing_feature”

Figure 6. Fixturing features and corresponding mapping for constructing kinematic joints

The majority of fixturing equipment has an array of fixturing features such as slots, sockets etc. This enables reconfigurability with fixturing elements. The information regarding such a fixturing configuration has to be stored to be able to be used for change in work setup, progression in work etc. The placement pattern of the fixturing configuration is described with UMRM’s entity “placement_pattern”. Two placement patterns, namely circular pattern and rectangular pattern can be presented using this entity. Thus, any fixturing feature such as location hole or fixturing slot can be

1
2
3 described once and used again for representing its progressive placement as shown on
4
5
6 Figure 7. The pattern placement has a distinct reference which can be presented using
7
8 an attribute “pattern_placement_reference”.
9

10 Fixturing features such as fixturing slots are utilised for holding and/or
11
12 clamping a workpiece and/or cutting. They can also be utilised for assembling one
13
14 mechanical machine element to another. There are **standard** slot profiles such as vee
15
16 profile, tee profile, rectangular profile utilised in most common fixturing devices.
17
18 UMRM unifies a variety of such slot profile under an abstract entity “fixturing_slot”.
19
20 Customised slot information can be represented by defining a trajectory and cut
21
22 section using a STEP entity “shape_representation”. In addition, it is possible to
23
24 represent information regarding slot end condition using a STEP entity
25
26 “end_condition”.
27
28
29
30

31
32 Similarly, machine tool manufacturers use customised elements for holding
33
34 tools and workpieces. Though there is an abundant diversity in the design of tool or
35
36 workpiece holders, the common element among these units is their purpose, namely to
37
38 **hold either** a workpiece or a tool. The proposed model for machine tool resources
39
40 emphasises the role of these elements. Hence, abstract entities, namely
41
42 “location_socket” and “location_shank” are designed within UMRM for generalising
43
44 and representing fixturing features.
45
46
47
48
49

50 Figure 7. Example of rectangular patterned fixturing features (tee profile slot) on the
51
52 table

53
54 The recursive nature of the entity “mechanical_machine_element” (Vichare *et*
55
56 *al.* 2009b) for representing CNC machining system resources has a capability of
57
58 representing functional details of the various sub systems of the parent CNC
59
60 machining system. For example, a machine tool is attached with the robotic arm. This

1
2
3 robotic arm has a capability of handling workpieces as well as cutting tool. This case
4
5 can be represented with attaching two “fixture_assly” entities to the robotic arm head.
6
7
8 One of which holds fixture setup for holding workpiece and other “fixture_assly”
9
10 holds another fixture setup for holding cutting tool. This has only been possible due to
11
12 the flexibility of mechanical machine element to hold a set of another mechanical
13
14 machine element, workpiece or cutting tool.
15
16

17
18 An entity “fixture_assly” shown in Figure 8 addresses locating, clamping and
19
20 supporting elements available in the fixture assembly. The fixture assembly can either
21
22 be modelled by using an entity “std_fixture_assly” for representing standard fixturing
23
24 devices such as a vise or the entity “modular_fixture_elements” for modelling a
25
26 reconfigurable fixture tower. For example, a V block vise can be modelled by
27
28 associating entity “fixturing_slot” to each vise jaw.
29
30
31
32

33
34 Figure 8. EXPRESS-G representation of the UMRM entity “fixture_assly”

35 36 **5. Representation of fixture specific information: a case study**

37 38 **5.1. Vertical indexing pallet setup**

39
40
41 A typical horizontal machining centre shown in the Figure 9 has a vertical indexing
42
43 pallet mounted on the C axis rotary table. The operation under consideration is
44
45 machining of blow mould for a bottle production. In the regular process planning
46
47 scenario with the aid of CAx systems, the manufacturing engineer has to model a
48
49 vertical indexing pallet assembly. Various details such as clamping and location units
50
51 have to be modelled for generating a collision free tool path. Manufacturing
52
53 engineer’s knowledge and experience is vital for planning such a fixturing setup.
54
55
56
57
58 Generating a resource specific tool path is the next step which is well-automated
59
60 using available CAM systems on the market. However, the machining setup for a

1
2
3 different job, using the same fixturing resources requires the engineer's intervention.
4
5
6 This is due to the fact that the configuration and capability information of these
7
8
9
10
11
12
13
14
15
16
17
18
19
20
21
22
23
24
25
26
27
28
29
30
31
32
33
34
35
36
37
38
39
40
41
42
43
44
45
46
47
48
49
50
51
52
53
54
55
56
57
58
59
60

different job, using the same fixturing resources requires the engineer's intervention. This is due to the fact that the configuration and capability information of these fixturing elements have not been modelled. In addition, exchanging fixture specific information in the computing environment for integrated product and process design is difficult due to lack of standard constructs.

Figure 9. A typical 4 axes horizontal machining centre with vertical indexing pallet

Thus, by using UMRM, the fixture specific information can be coupled with the machine tool specific information. Every mechanical machine element modelled using UMRM carries fixturing features. Table 1 illustrates various mechanical machine elements and corresponding fixturing features for modelling horizontal machining centre with vertical indexing pallet. Representation of the fixture element and corresponding fixturing features for constructing kinematic pair are illustrated in the table. For example, a rotary table of the machine is a mechanical machine element which has T-slots; and vertical indexing pallet's base has location sockets. Thus, these two fixturing features can be mapped on each other for constructing rigid kinematic joint. Standard fastener library can be utilised to select required fasteners for constructing a kinematic joint. The fixturing feature represents available provisions i.e. slots, locating sockets, locating shanks of the mechanical machine element for assembling it with another machine element. For example, four vertical walls of the pallet have a grid of locating holes as shown in the Figure 9; few of them are utilised for assembling fixed jaw, movable jaw and a step block. However, by using an entity "placement_pattern", the placement of the every location hole can be stored and utilised in the fixture reconfiguration.

5.2. Fixturing setup representation using a STEP part 21 file

A part 21 file (also known as .stp or .step file) can represent geometry of the assembly by using ASCII clear text encoding format (ISO 10303-21 1994). The STEP application protocol (AP) for generating this part 21 file has a mechanism to display geometric entities of the assembly. However, this AP does not preserve the context of such geometric entities in the part 21 file. Thus, UMRM provides a mechanism to store the functionality information of such geometric entities by using a data model explained in section 4.

The vertical indexing pallet and available fixturing features can be represented with the UMRM's entity "fixturing_config". The machine table is a circular type and has T-slots which are represented by using entities "tee_slot" and "placement_pattern". The vertical indexing pallet has a grid of location holes that can be used for assembling various fixturing elements such as reconfigurable clamps, supporting plate etc. Finally, the entity "fixture_assly", a subtype of "mechanical_machine_element" addresses elements required for clamping, locating and supporting the workpiece. Thus, configuration of the vertical indexing pallet, reconfigurable clamp and supporting plate can be represented by using UMRM entities for enhancing the automated process planning capability. Thus, specific fixturing setup details such as location configuration, clamping points, location elements can be represented using a UMRM's data model with part 21 file as shown in the Figure 10. This Part 21 file based on the existing STEP, STEP-NC and UMRM information constructs can be used by a variety of manufacturing application shown in Figure 11.

1
2
3
4
5 Table 1. Fixturing features and corresponding mapping for constructing kinematic
6 joints
7
8
9

10 Figure 10. An extract of the part 21 file for representing manufacturing resources
11
12
13
14

15 **5.3. Fixturing knowledge generation and preservation for developing large volume** 16 **build philosophies** 17 18

19
20
21
22
23 Fixturing setup in aerospace and automotive manufacturing sectors is also known by
24
25 the term “tooling”. Tooling in these manufacturing sectors constitutes large
26
27 mechanical structures such as assembly jigs, component handling frames, transfer line
28
29 jigs, large sheet metal dies etc. The design of these tooling components is well
30
31 researched through the feasibility studies before releasing for the production
32
33 environment. Significant amount of knowledge regarding fixture design is generated
34
35 in these feasibility studies, which became an asset of the business for excelling key
36
37 competencies. However key challenges in fixturing knowledge representation are
38
39 rooted through the basic questions such as: What information regarding fixturing
40
41 setup is needed for representing fixturing knowledge, How this information can be
42
43 modelled, utilised throughout the product manufacture and preserved for designing
44
45 next generation of the product manufacturing philosophies.
46
47
48
49

50
51 UMRM has been utilised as a fixturing information generation template for
52
53 representing fixturing setup information in the form of part 21 file as described in
54
55 section 5.2. Figure 11 illustrates UMRM’s framework for generating fixturing setup
56
57 information and utilising it in various manufacturing applications used in product
58
59
60

1
2
3 design and development. UMRM's EXPRESS schema can be acquired for further
4
5
6 development by contacting corresponding author.
7
8
9

10 11 12 13 14 **6. Conclusions and future work**

15
16
17 In this paper, authors have proposed a UMRM for representing fixture specific
18
19 information for CNC manufacture. The UMRM has a rich data model which has a
20
21 promising potential for representing manufacturing resource domains such as machine
22
23 tools, material handling systems including fixturing setup. A case study is presented,
24
25 in which vertical pallet setup has been represented with the part 21 file. Thus, UMRM
26
27 can represent the kinematic chain between tool and workpiece considering fixture
28
29 configurations. In addition to geometric entities, unlike commercially available tools,
30
31 UMRM can represent logical purpose of the available manufacturing resources. At
32
33 present, UMRM's data model can represent the information required for tool path
34
35 verification. However, adding fixture specific information has enabled UMRM to be
36
37 used for developing reconfigurable process plans. It utilised pre-established
38
39 standardised information constructs for representing information regarding a range of
40
41 kinematic joints; thus, it can be utilised to establish a neutral file format for
42
43 exchanging resource information including fixturing information in the CAx chain.
44
45
46
47
48
49

50
51 Further developments, especially for modelling the application oriented
52
53 behaviour of the resource elements, are aimed at the extension for representing CNC
54
55 machining system. UMRM's Resource information can be considered as a focal
56
57 aspect for developing solutions for ever-challenged research areas such as design of
58
59
60

1
2
3 interoperable and reconfigurable manufacturing environment, intelligent controller,
4
5 resource integration in the supply chain etc due to its wide scope.
6
7
8
9

10 11 **7. Acknowledgement** 12

13
14
15 The work reported in this paper has been undertaken as part of the EPSRC
16
17 Innovative Design and Manufacturing Research Centre at the University of Bath
18
19 (Grant reference EP/E00184X/1) and supported by a number of industrial companies.
20
21 The authors gratefully acknowledge this support and express their thanks for the
22
23 advice and support of all concerned.
24
25
26
27
28
29
30
31
32
33
34
35
36
37
38
39
40
41
42
43
44
45
46
47
48
49
50
51
52
53
54
55
56
57
58
59
60

References

- 1
2
3
4
5
6 Bi, Z.M., Lang, Y.T., Verner, M. & Orban, P., 2008. Development of reconfigurable
7 machines. *Int J Adv Manuf Technol*, 39 (11-12), 1227-1251.
- 8 Bouti, A. & Ait Kadi, D., 1998. Capturing manufacturing systems knowledge using
9 multi-view modelling. *International Journal of Computer Integrated*
10 *Manufacturing*, 11 (1), 77-93.
- 11 Bugtai, N. & Young, R.I.M., 1998. Information models in an integrated fixture
12 decision support tool. *Journal of Materials processing Technology*, 76, 29-35.
- 13 Cecil, J., 2001. Computer-aided fixture design - a review and future trends *Int J Adv*
14 *Manuf Technol*, 18, 790-793.
- 15
16 Cochrane, S., Young, R., Case, K., Harding, J., Gao, J., Dani, S. & Baxter, D., 2009.
17 Manufacturing knowledge verification in design support systems.
18 *International Journal of Production Research*, 47 (12), 3179-3204.
- 19 Dai, J.R., Nee, A.Y.C., Fuh, J.Y.H. & Kumar, A.S., 1997. An approach to automating
20 modular fixture design and assembly. *Proceedings of the Institution of*
21 *Mechanical Engineers, Part B: Journal of Engineering Manufacture*, 211,
22 509-521.
- 23
24 ISO 10303-21, Industrial automation systems and integration — product data
25 representation and exchange, part 21: Implementation methods: STEP-file
26 clear text encoding of the exchange structure 1994.
- 27
28 ISO 10303-105, Industrial automation systems and integration — product data
29 representation and exchange, part 105: Integrated application resources:
30 Kinematics 1996.
- 31
32 ISO 14649-1, Industrial automation systems and integration — physical device
33 control — data model for computerized numerical controllers, part 1:
34 Overview and fundamental principles 2002.
- 35
36 Kjellberg, T., Von Euler-Chelpin, A., Hedlind, M., Lundgren, M., Sivard, G. & Chen,
37 D., 2009. The machine tool model—a core part of the digital factory. *Annals*
38 *of the CIRP*, 58 (1), 425-428.
- 39
40 Kow, T.S., Kumar, A.S. & Fuh, J.Y.H., 2000. An integrated approach to collision-free
41 computer-aided modular fixture design. *Int J Adv Manuf Technol*, 16, 233-
42 242.
- 43
44 Liqing, F. & Kumar, A.S., 2005. XML-based representation in a CBR system for
45 fixture design. *Computer-Aided Design & Applications*, 2 (1-4), 339.
- 46
47 Mervyn, F., Kumar, A.S. & Nee, A.Y.C., 2006. Fixture design information support
48 for integrated design and manufacturing. *International Journal of Production*
49 *Research*, 44 (11), 2205-2219.
- 50
51 Molina, A. & Bell, R., 2002. Reference models for the computer aided support of
52 simultaneous engineering. *international Journal of Computer Integrated*
53 *Manufacturing*, 15 (3), 193-213.
- 54
55 Nassehi, A. & Vichare, P., 2008. Determination of component machineability in CNC
56 manufacture *Proceedings of the FAIM2008*, Skövde, Sweden, 23-30.
- 57
58 Nassehi, A. & Vichare, P., 2009. A STEP-NC compliant methodology for modelling
59 manufacturing resources. In Xu, X.W. & Nee, A.Y.C. eds. *Advanced design*
60 *and manufacturing based on STEP*. Springer London, 261-281.
- Newman, S.T. & Nassehi, A., 2006. Universal manufacturing platform for CNC
machining. *Annals of the CIRP*, 56 (1), 459-462.

- 1
2
3 Padmanaban, K.P. & Prabhakaran, G., 2008. Dynamic analysis on optimal placement
4 of fixturing elements using evolutionary techniques. *International Journal of*
5 *Production Research*, 46 (15), 4177-4214.
6
7 Pehlivan, S. & Summers, J.D., 2008. A review of computer-aided fixture design with
8 respect to information support requirements. *International Journal of*
9 *Production Research*, 46 (4), 929-947.
10
11 Rachuri, S., Baysal, M., Roy, U., Foufou, S., Bock, C., Fenves, S., Subrahmanian, E.,
12 Lyons, K. & Sriram, R., 2005. Information models for product representation:
13 Core and assembly models. *International Journal of Product Development*
14 2(3), 207-235.
15
16 Sato, M., 2006. Design and performance of 5 axis machines in japan *Proceedings of*
17 *the 12th International Machine Tool Engineer's Conference*, Tokyo, Japan,
18 167-189.
19
20 Vichare, P., Nassehi, A., Kumar, S. & Newman, S.T., 2009a. A unified manufacturing
21 resource model for representation of CNC machining systems elements.
22 *Robotics and Computer Integrated Manufacturing*, 25 (6), 999-1007.
23
24 Vichare, P., Nassehi, A. & Newman, S.T., 2009b. A unified manufacturing resource
25 model for representation of CNC machine tools. *Proc. IMechE, Part B: J.*
26 *Engineering Manufacture*, 223 (5), 463-483.
27
28 Yao, Y., Liu, C. & Li, J., 2005. Web-based virtual machining and measuring cell
29 *Proceedings of the 9th International Conference on Computer Supported*
30 *Cooperative Work in Design*, 673-678.
31
32 Zhao, J., Cheung, W.M. & Young, R.I.M., 1999. A consistent manufacturing data
33 model to support virtual enterprises. *International Journal of Agile*
34 *Management Systems*, 1-3, 150-158.
35
36
37
38
39
40
41
42
43
44
45
46
47
48
49
50
51
52
53
54
55
56
57
58
59
60

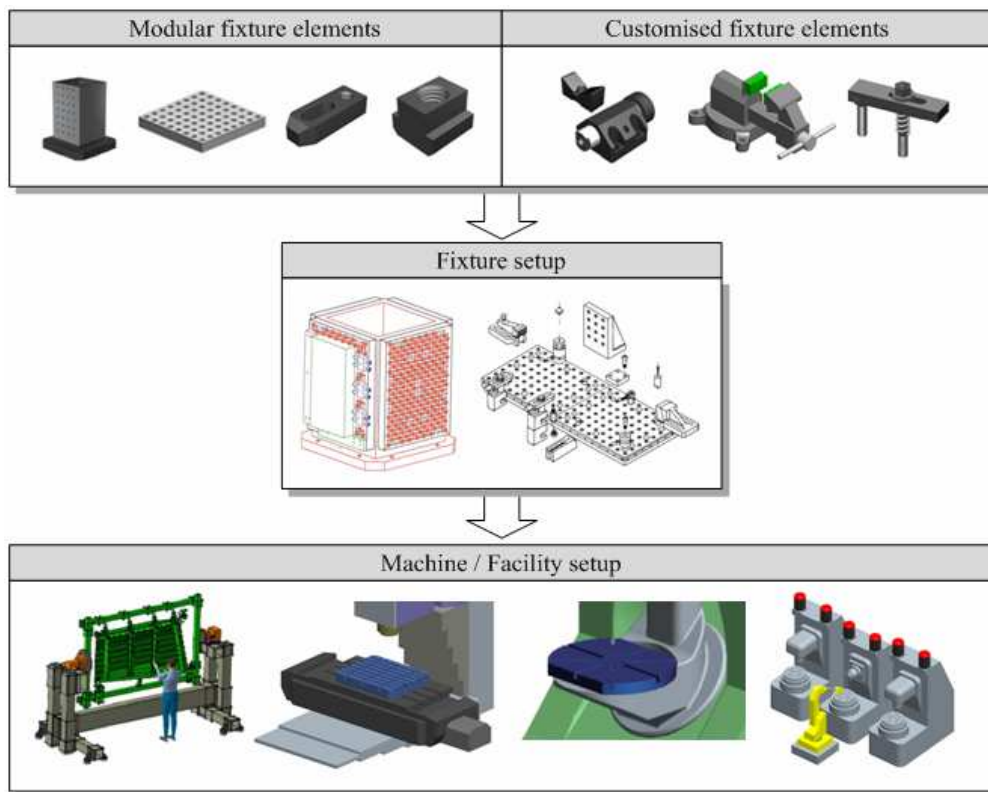

Figure 1: Use of modular and customised fixturing elements in the CNC machining operation

1
2
3
4
5
6
7
8
9
10
11
12
13
14
15
16
17
18
19
20
21
22
23
24
25
26
27
28
29
30
31
32
33
34
35
36
37
38
39
40
41
42
43
44
45
46
47
48
49
50
51
52
53
54
55
56
57
58
59
60

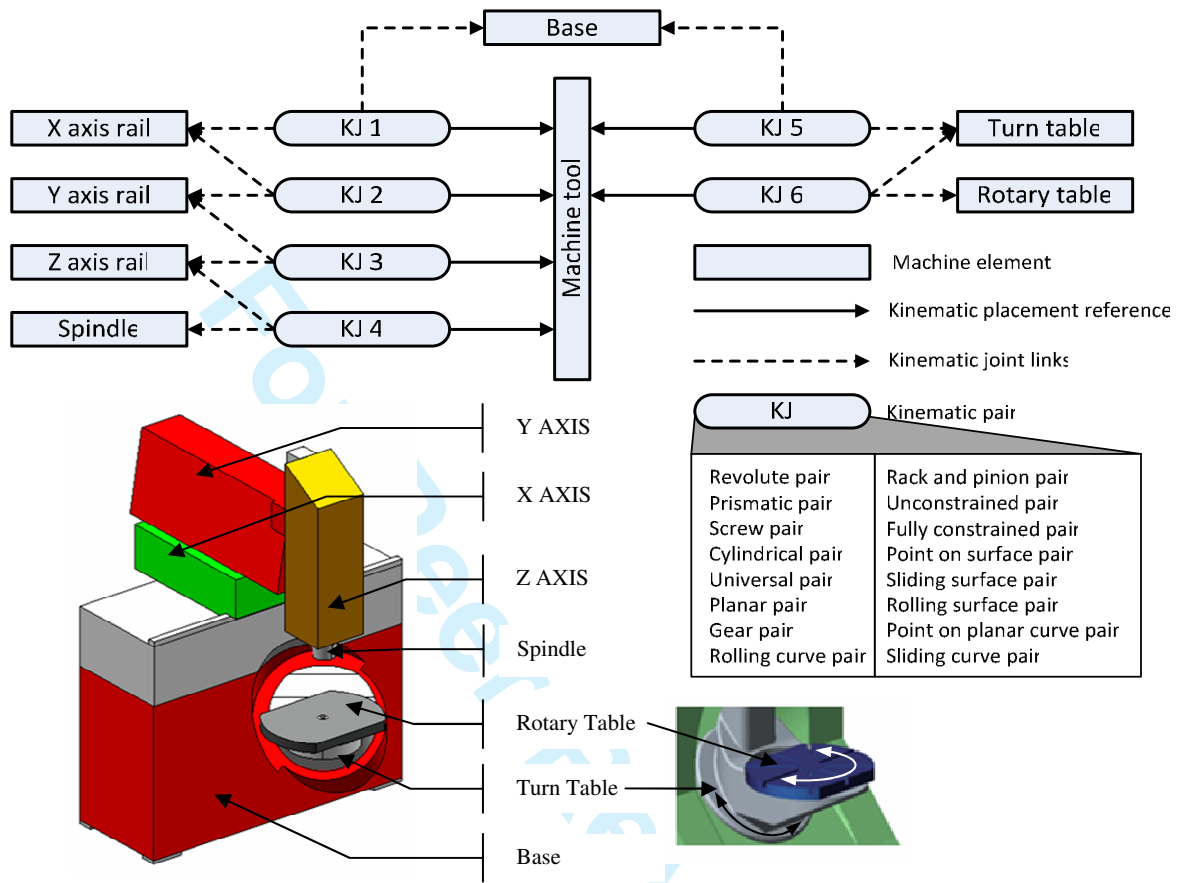

Figure 2: Machine tool configuration and corresponding kinematic representation using STEP's IR

105 [1]

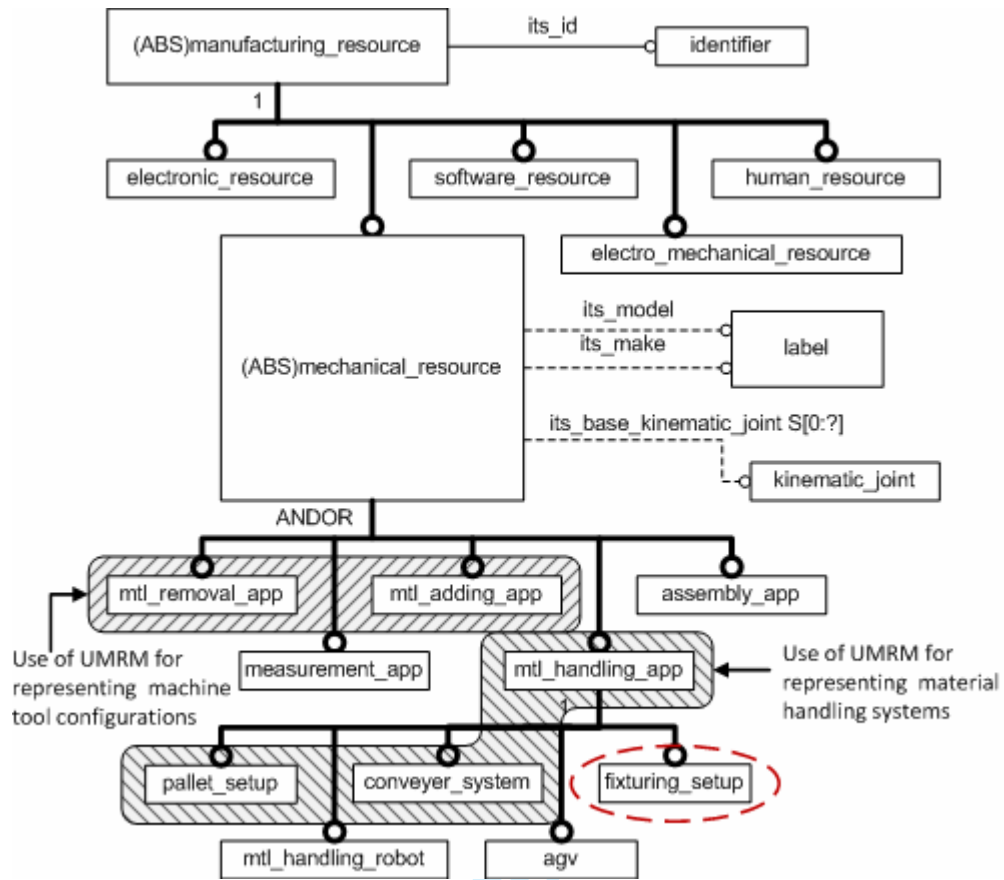

Figure 3: EXPRESS-G representation of UMRM entity "manufacturing_resource" for representing fixturing setup

1
2
3
4
5
6
7
8
9
10
11
12
13
14
15
16
17
18
19
20
21
22
23
24
25
26
27
28
29
30
31
32
33
34
35
36
37
38
39
40
41
42
43
44
45
46
47
48
49
50
51
52
53
54
55
56
57
58
59
60

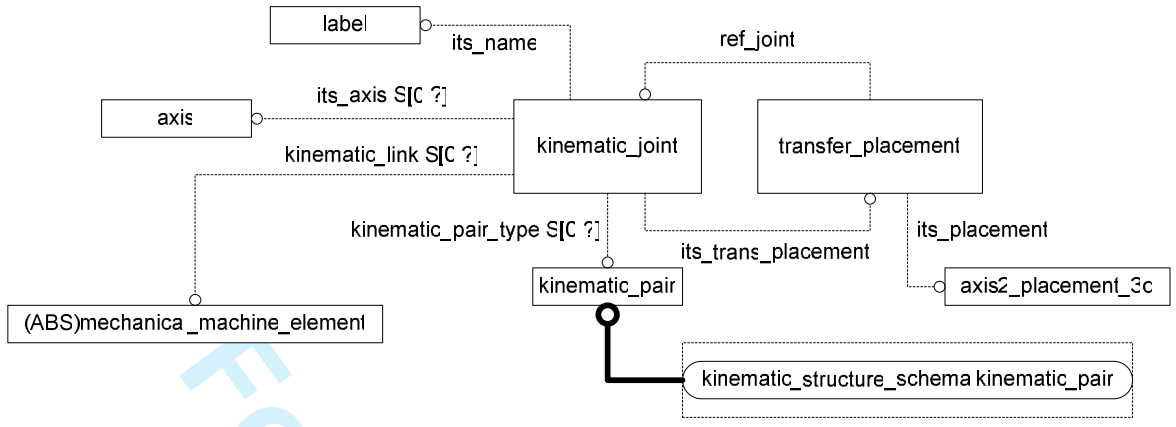

Figure 4: EXPRESS-G representation of UMRM entity "kinematic_joint"

For Peer Review Only

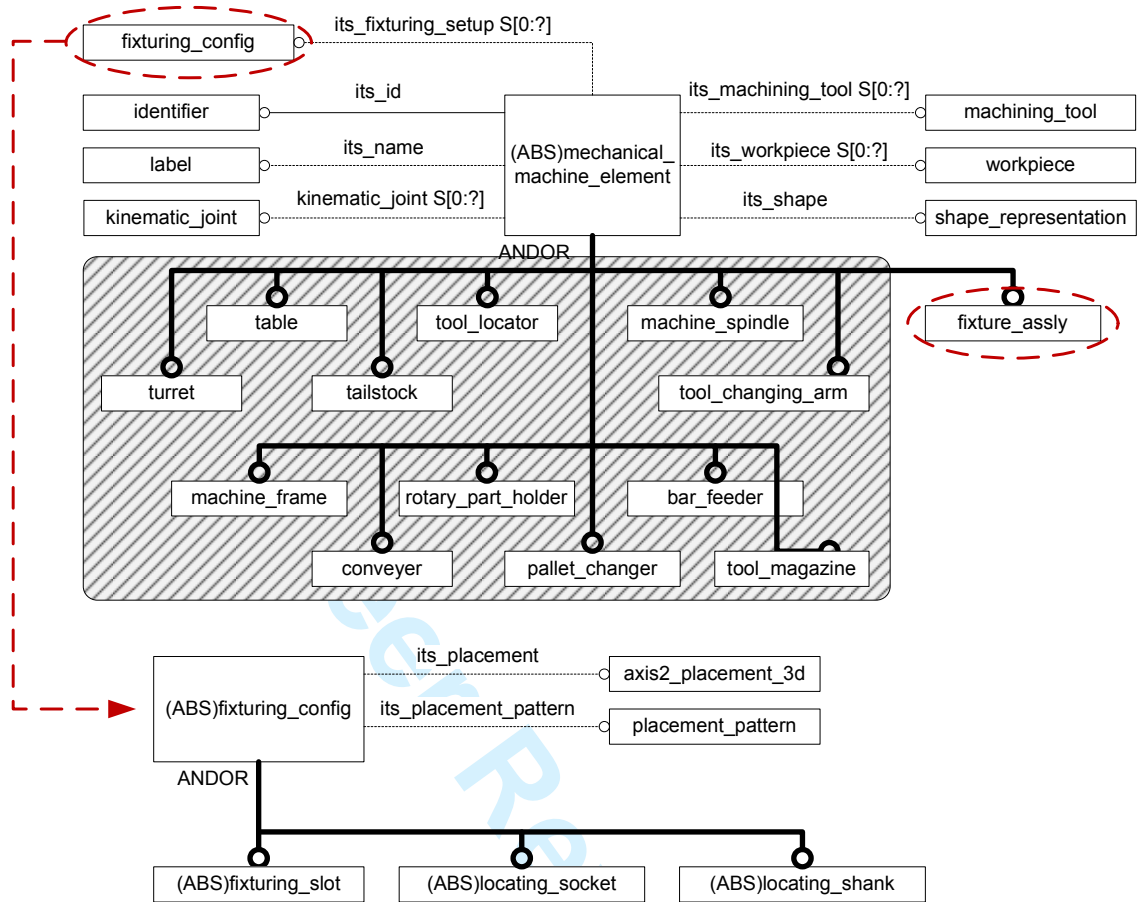

Figure 5: EXPRESS-G representation of the UMRM entities “mechanical_machine_element” and “fixturing_feature”

1
2
3
4
5
6
7
8
9
10
11
12
13
14
15
16
17
18
19
20
21
22
23
24
25
26
27
28
29
30
31
32
33
34
35
36
37
38
39
40
41
42
43
44
45
46
47
48
49
50
51
52
53
54
55
56
57
58
59
60

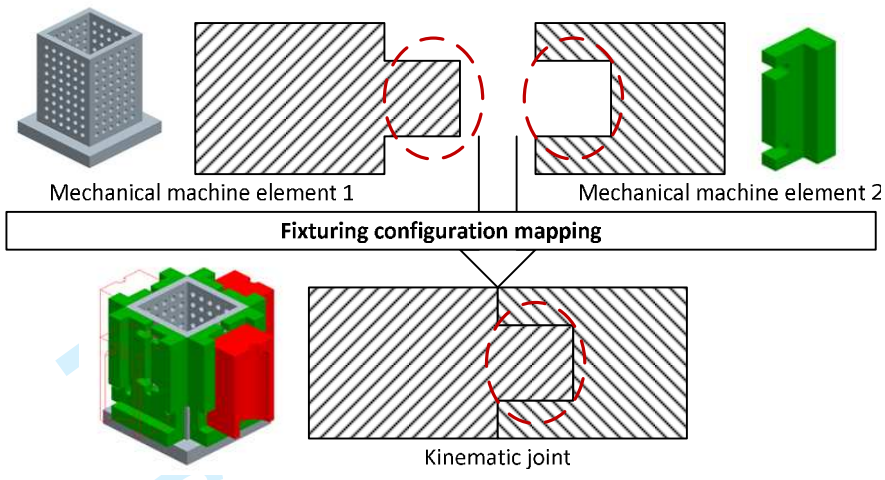

Figure 6: Fixturing features and corresponding mapping for constructing kinematic joints

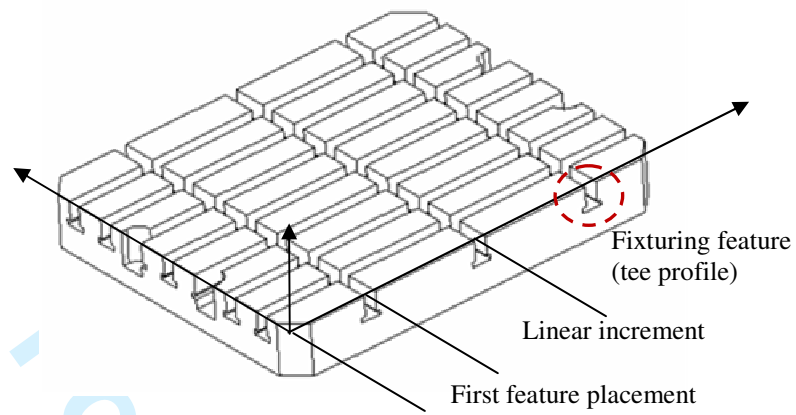

Figure 7: Example of rectangular patterned fixturing features (tee profile slot) on the table

1
2
3
4
5
6
7
8
9
10
11
12
13
14
15
16
17
18
19
20
21
22
23
24
25
26
27
28
29
30
31
32
33
34
35
36
37
38
39
40
41
42
43
44
45
46
47
48
49
50
51
52
53
54
55
56
57
58
59
60

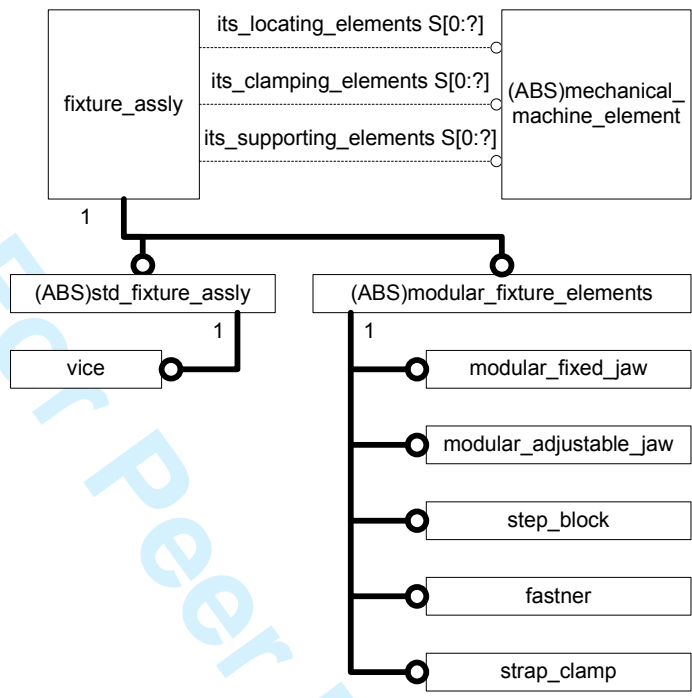

Figure 8: EXPRESS-G representation of the UMRM entity "fixture_assly"

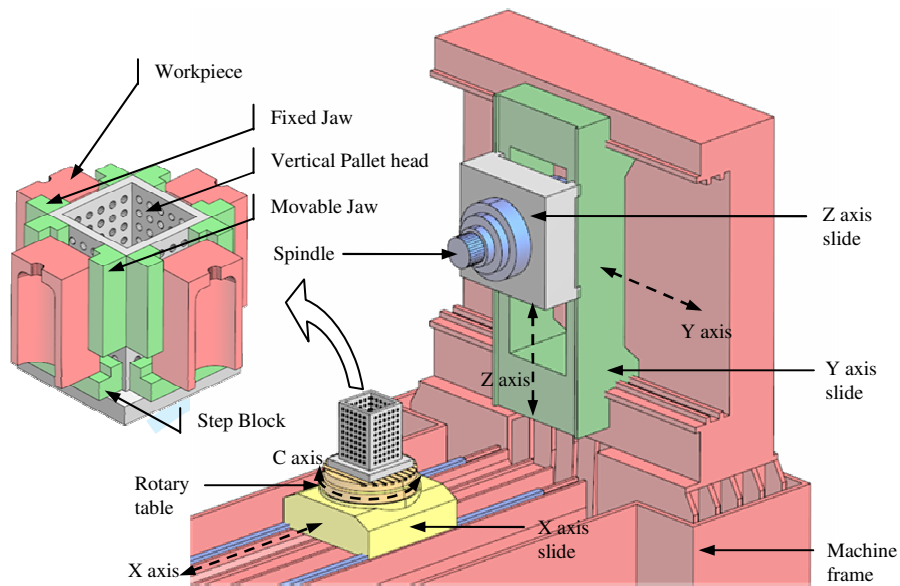

Figure 9: A typical 4 axes horizontal machining centre with vertical indexing pallet

```

1
2
3
4
5
6 ISO-10303-21;
7 HEADER;
8 FILE_DESCRIPTION('MCM PALLET CHANGER', 'MCM', '1');
9 FILE_NAME('MCM_PALLET_CHANGER.STP', '2009-02-04', ('PARAG VICHARE', 'AYDIN
10 NASSEHI', 'STEPHEN NEWMAN'), ('UNIVERSITY OF BATH'), $, 'ISO14649', $);
11 FILE_SCHEMA(('MACHINING_SCHEMA', 'TURNING_SCHEMA', 'MILLING_SCHEMA', 'MILLING_TO
12 OL_SCHEMA', 'TURNING_MACHINE_TOOL_SCHEMA', 'UMRM_SCHEMA', 'AUTOMOTIVE_DESIGN'));
13 ENDSEC;
14
15 DATA;
16 #1 = MECHANICAL_DESIGN_GEOMETRIC_PRESENTATION_REPRESENTATION('',
17 (#73, #74, #75, #76, #77, #78, #79, #80), #105);
18 #2 = PRODUCT_DEFINITION_CONTEXT('', #100, 'PART DEFINITION');
19 #3 = APPLICATION_PROTOCOL_DEFINITION('INTERNATIONAL STANDARD', '', #100);
20 #4 = SHAPE_DEFINITION_REPRESENTATION(#101, #102);
21 .
22 #101 = PRODUCT_DEFINITION_SHAPE('NONE', 'NONE', #372);
23 #102 =
24 ADVANCED_BREP_SHAPE_REPRESENTATION('BED_ASSLY', (#420, #421, #422, ...), #105);
25 .
26 #1526 = WORK_STATION('MCM PALLET CHANGER', #1520, (#1628, #1629);
27 #1628 = MACHINE_TOOL('MCM HMC', '', 'MCM', #1628);
28 #1629 = FIXTURING_SETUP('PALLET CHANGER', #1629);
29 .
30 #2346 = MODULAR_FIXED_JAW(...);
31 #2347 = MODULAR_ADJUSTABLE_JAW(...);
32 #2348 = STEP_BLOCK(...);
33 .
34 #2543 = TEE_PROFILE(#2544, #2549, #2568, #....);
35 #2549 = PLACEMENT_PATTERN(#2570, #2550);
36 #2550 = RECT_PATTERN(#2551,);
37 #2551 = ROW_CONFIG(#2552);
38 #2552 = FEATURE_PLACEMENT(80.000, 50.000, 8);
39 .
40 #2589 = LOCATION_HOLE_SOCKET(#2621, #2626, 15.000, 10.000, '');
41 .
42 #3521 = FIXTURE_ASSLY((), (#2346, #2347), (#2348));

```

Header

Geometry description

Manufacturing resources

Fixture assembly elements

Fixturing features

Location holes on the pallet

Figure 10: An extract of the part 21 file for representing manufacturing resources

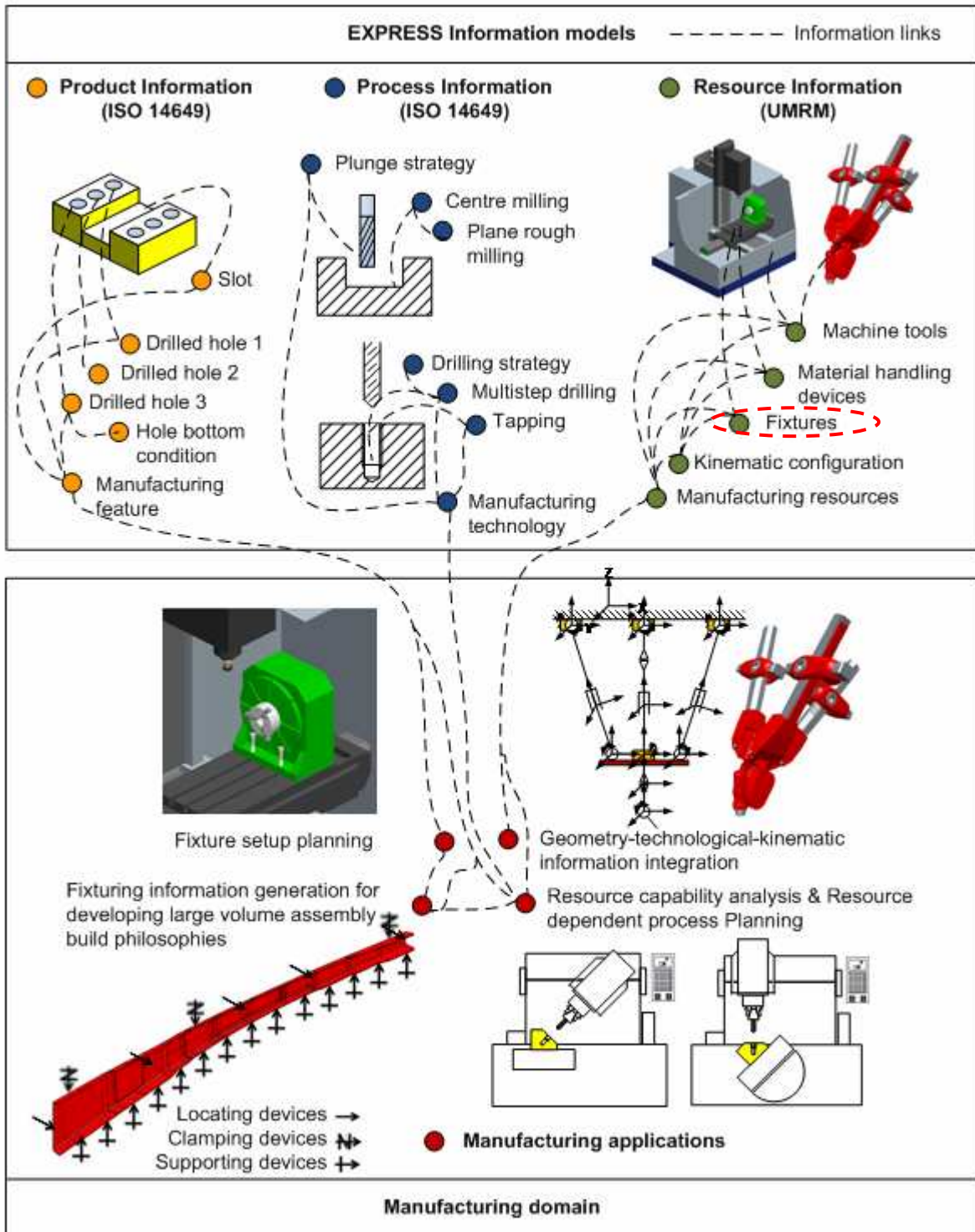

Figure 11: UMRM's framework for generating fixturing setup information and utilizing it in various manufacturing applications used in product design and development

Table 1: Fixturing features and corresponding mapping for constructing kinematic joints

Mechanical machine element	Fixturing feature	Kinematic pair library (ISO 10303-105)	Fixturing feature	Mechanical machine element
Machine frame	→	Prismatic pair	←	Y axis slide
Y axis slide	→	Prismatic pair	←	Z axis slide
Z axis slide	→	Fully constrained pair	←	Spindle
Machine frame	→	Prismatic pair	←	X axis slide
X axis slide	→	Revolute pair	←	Rotary table
Rotary table→	Fixturing slot→	Fully constrained pair	←Locating socket	←Pallet head
Pallet head→	Locating socket→	Fully constrained pair	←Locating socket	←Fixed jaw
Pallet head→	Locating socket→	Fully constrained pair	←Locating socket	←Movable jaw
Pallet head→	Locating socket→	Fully constrained pair	←Locating socket	←Step block