



HAL
open science

On the unknown input observer design : a decoupling class approach with application to sensor fault diagnosis

Souad Bezzaoucha, Benoît Marx, Didier Maquin, José Ragot

► To cite this version:

Souad Bezzaoucha, Benoît Marx, Didier Maquin, José Ragot. On the unknown input observer design : a decoupling class approach with application to sensor fault diagnosis. 1st International Conference on Automation and Mechatronics, CIAM'2011, Nov 2011, Oran, Algeria. pp.CDROM. hal-00630390

HAL Id: hal-00630390

<https://hal.science/hal-00630390>

Submitted on 8 Apr 2014

HAL is a multi-disciplinary open access archive for the deposit and dissemination of scientific research documents, whether they are published or not. The documents may come from teaching and research institutions in France or abroad, or from public or private research centers.

L'archive ouverte pluridisciplinaire **HAL**, est destinée au dépôt et à la diffusion de documents scientifiques de niveau recherche, publiés ou non, émanant des établissements d'enseignement et de recherche français ou étrangers, des laboratoires publics ou privés.

On the Unknown Input Observer Design : a Decoupling Class Approach with Application to Sensor Fault Diagnosis

Souad Bezzaoucha, Benoît Marx, Didier Maquin, José Ragot

Abstract— This paper addresses fault diagnosis for observer-based residual generators for linear discrete-time systems subject to unknown input. The proposed approach is a new method allowing to characterize a class of unknown inputs from which the estimation error is decoupled. This contribution is divided into two parts. The first one concerns the design of the UIO satisfying either an exact decoupling or an \mathcal{L}_2 -attenuation of the unknown input to the state estimation error. The second part is dedicated to the implementation of a bank of such observers for sensor fault detection and isolation.

I. INTRODUCTION

Due to an increasing demand for higher performances, safety and reliability, fault diagnosis for uncertain systems with Unknown Input (UI) has received considerable interest. Since in many cases a part of the system input is inaccessible (e.g. plant disturbance or actuator failure), a conventional observer that requires the knowledge of all inputs cannot be used directly; then Unknown Input Observers (UIOs) were developed to estimate the state of uncertain systems despite the existence of UIs or disturbances [3], [1], [6], [9], [10], [11].

Classically, the state estimation of a system subject to UI can be obtained by means of the so-called UIO. The goal of the UIO is to provide state reconstruction of the system with some robustness with respect to possible UI. Design of UIO has been extensively investigated in the literature and is based either on the decoupling such that the estimation error do not depend on the UI [22] [11] [6], or on the synthesis of an Integral Observer for the estimation of disturbances [20] [12] [13]. These strategies frequently require structural and rank constraints on the system matrices.

In this paper, the proposed strategy consists to decompose any UI into two terms. The first one is a sum of exponential functions from which the state estimates can be exactly decoupled. For a given system, the class of the UI satisfying that property is clearly established. The effect of the remaining part of the UI on the state estimates is then attenuated in an \mathcal{L}_2 framework.

Then, the proposed UIO design will be applied to investigate a sensor fault detection and isolation problem. A method based on the design of an observer bank will be used. This approach uses the proposed observer in a bank of observers. Residues corresponding to each observer are

generated and defined in such a way to detect the fault occurrence; coupled with a residual analysis methods, the faulty instrument (sensor in the considered case) is identified.

Different schemes of bank observers can be used for fault diagnosis (Dedicated Observer Scheme, Generalized Observer Scheme,...), see [4] [14] [7]. In this paper, a Generalized Observer Scheme (GOS) is applied. The bank consists of $N + 1$ observers that include N fault observers and one normal condition observer. The i^{th} observer is driven by all inputs and $N - 1$ outputs of the system and generates the corresponding residual vector r_k^i . Then, these residual vectors are evaluated for fault detection and localisation.

This paper is organised as follows : Section II presents a second order system to introduce the decoupling strategy and the *Unknown Input Class for exact decoupling* notion and how to generate this class. Section III is a generalization of the second section. In section IV, we introduce the notion of partial decoupling and the linear matrix inequalities conditions to ensure the \mathcal{L}_2 attenuation of the UI effect on state estimates. In order to improve the obtained results, a pole assignment is also implemented.

However, the usual linearization approaches are not suitable to the present problem since BMIs (Bilinear Matrix Inequalities) are to be dealt with. A gain adjustment technique is then applied. This synthesis linearize the inequalities by fixing one of the unknown variable [16]. This kind of procedure can be found in the centrage-XY procedure [15], the D-K iteration mentioned in [19] or Yamada's approach [21].

In section V, simulations are presented to show the efficiency of the proposed approach. And finally, in the last section, as an application, a residual generator design in a case of a sensor fault is addressed.

II. ILLUSTRATIVE EXAMPLE

To begin with, the procedure is introduced with the help of a simple example being a second order system. The different steps leading to the *Unknown Input Class* for exact decoupling are detailed. Consider a second order system described by :

$$\begin{cases} x_{k+1} &= Ax_k + Bu_k + D\eta_{k-1} \\ y_k &= Cx_k + e\eta_{k-1} \end{cases} \quad (1)$$

where $x_k \in \mathbb{R}^2$, $u_k \in \mathbb{R}$, $\eta_k \in \mathbb{R}$ and $y_k \in \mathbb{R}$ are the system state, input, unknown input and the output vector respectively. The system matrices are real valued, constant and of appropriate dimensions :

The authors are with Centre de Recherche en Automatique de Nancy (CRAN), Nancy-University, CNRS, 2 avenue de la Forêt de Haye F-54516 Vandoeuvre-les-Nancy. `firstname.name@ensem.inpl-nancy.fr`

$$x_k = \begin{bmatrix} x_{1k} \\ x_{2k} \end{bmatrix} \quad A = \begin{bmatrix} a_{11} & a_{12} \\ a_{21} & a_{22} \end{bmatrix} \quad B = \begin{bmatrix} b_1 \\ b_2 \end{bmatrix} \\ C = [c_1 \quad c_2] \quad D = \begin{bmatrix} d_1 \\ d_2 \end{bmatrix} \quad (2)$$

The proposed Proportional Integral Observer (PIO) of gain K and the UIO depending on an auxiliary variable $z_k \in \mathbb{R}$ are respectively given by the following equations :

$$\begin{cases} \hat{x}_{k+1} &= A\hat{x}_k + Bu_k + D\hat{\eta}_{k-1} + K\tilde{y}_k \\ \hat{y}_k &= C\hat{x}_k + e\hat{\eta}_{k-1} \\ \tilde{y}_k &= y_k - \hat{y}_k \end{cases} \quad (3)$$

$$\begin{cases} z_{k+1} &= \gamma_1 \tilde{y}_k + \lambda_1 z_k \\ \hat{\eta}_{k+1} &= \gamma_2 z_k + \lambda_2 \hat{\eta}_k \end{cases} \quad (4)$$

with :

$$K = \begin{bmatrix} k_1 \\ k_2 \end{bmatrix}$$

It can be noted that the UIO has a filter structure with as an input the output reconstruction error \tilde{y}_k . The filter parameters γ_1 , γ_2 , λ_1 and λ_2 allow to modify the gain and time constants of the UIO. Depending on the value of the UIO parameters, we can have either a proportional observer, an integral or a multiple integral observer. In this particular case, the choice $\lambda_1 = 1$ or $\lambda_2 = 1$ introduces the two integrators in this filter structure.

In the following, the state and UI estimation errors are expressed as function of the UI. Since the system and its observer are linear, the time shift operator q ($qf_k = f_{k+1}$), is adequate to express the reconstruction errors :

$$\begin{aligned} \tilde{x}_k &= x_k - \hat{x}_k \\ \tilde{\eta}_k &= \eta_k - \hat{\eta}_k \end{aligned} \quad (5)$$

From equations (1), (3) and (4), the state reconstruction error of the UI is given by :

$$\begin{cases} \tilde{x}_{1k} = \frac{N_1(q)}{D(q)} \eta_k \\ \tilde{x}_{2k} = \frac{N_2(q)}{D(q)} \eta_k \end{cases} \quad (6)$$

$$\begin{cases} N_1(q) = (q - \lambda_1)(q - \lambda_2)(\tilde{a}_{12}\tilde{d}_2 - \tilde{a}_{22}\tilde{d}_1 + q\tilde{d}_1) \\ N_2(q) = (q - \lambda_1)(q - \lambda_2)(\tilde{a}_{21}\tilde{d}_1 - \tilde{a}_{11}\tilde{d}_2 + q\tilde{d}_2) \\ D(q) = ((q - \lambda_1)(q - \lambda_2) + \gamma e)((q - \tilde{a}_{11})(q - \tilde{a}_{22}) - \tilde{a}_{12}\tilde{a}_{21}) \\ + \gamma c_1(\tilde{a}_{12}\tilde{d}_2 - \tilde{a}_{22}\tilde{d}_1 + q\tilde{d}_1) + \gamma c_2(\tilde{a}_{21}\tilde{d}_1 - \tilde{a}_{11}\tilde{d}_2 + q\tilde{d}_2) \end{cases} \quad (7)$$

with :

$$\begin{cases} \tilde{a}_{11} = a_{11} - k_1 c_1 \\ \tilde{a}_{12} = a_{12} - k_1 c_2 \\ \tilde{a}_{21} = a_{21} - k_2 c_1 \\ \tilde{a}_{22} = a_{22} - k_2 c_2 \\ \tilde{d}_1 = d_1 - k_1 e \\ \tilde{d}_2 = d_2 - k_2 e \end{cases} \quad (8)$$

From (6), conditions for the estimation errors to be independent from the UI can easily be derived. Then, the UI family satisfying an exact decoupling is solution of :

$$\begin{cases} \frac{N_1(q)}{D(q)} \eta_k = 0 \\ \frac{N_2(q)}{D(q)} \eta_k = 0 \end{cases} \quad (9)$$

In order to find the solution η_k assuring the previous conditions, it is imposed that polynomials $N_1(q)$ and $N_2(q)$ have the same roots. However, before that, it should also be checked if some solutions are common to $D(q)$ and $N_1(q)$ (or $N_2(q)$).

That leads to :

$$q_0 = \frac{\tilde{a}_{21}\tilde{d}_1 - \tilde{a}_{11}\tilde{d}_2}{\tilde{d}_2} \quad (10)$$

which is a common root between $N_1(q)$, $N_2(q)$ and $D(q)$.

Thus condition (9) is reduced to :

$$(q - \lambda_1)(q - \lambda_2)\eta_k = 0 \quad (11)$$

The solution is given by an UI being the sum of two exponential functions :

$$\eta_k = A_1 \lambda_1^k + A_2 \lambda_2^k \quad (12)$$

where coefficients A_1 and A_2 are arbitrarily set. Finally, the choice of the observer values λ_1 and λ_2 (4) gives the UI class assuring the exact decoupling of the state error from η_k for any values of the coefficients A_1 and A_2 .

III. RECONSTRUCTION ERRORS : DISTURBANCES DECOUPLING

Let us now return to the general case by using the following system equations :

$$\begin{cases} x_{k+1} &= Ax_k + Bu_k + D\eta_{k-1} \\ y_k &= Cx_k + e\eta_{k-1} \end{cases} \quad (13)$$

Vectors $x_k \in \mathbb{R}^n$, $u_k \in \mathbb{R}^m$, $\eta_k \in \mathbb{R}$ and $y_k \in \mathbb{R}^p$ are the system state, input, unknown input and the output vectors respectively. The system matrices $A \in \mathbb{R}^{n \times n}$, $B \in \mathbb{R}^{n \times m}$, $D \in \mathbb{R}^{n \times 1}$, $C \in \mathbb{R}^{p \times n}$ et $e \in \mathbb{R}^{p \times 1}$ are known real values. The proposed system observer of gain K and the UIO are respectively given by the following equations :

$$\begin{cases} \hat{x}_{k+1} &= A\hat{x}_k + Bu_k + D\hat{\eta}_{k-1} + K\tilde{y}_k \\ \hat{y}_k &= C\hat{x}_k + e\hat{\eta}_{k-1} \\ \tilde{y}_k &= y_k - \hat{y}_k \end{cases} \quad (14)$$

$$\begin{cases} z_{k+1} &= \Gamma \tilde{y}_k + \Lambda z_k \\ \hat{\eta}_{k+1} &= \gamma z_k + \lambda \hat{\eta}_k \end{cases} \quad (15)$$

with appropriate dimensions : $z_k \in \mathbb{R}^q$, $K \in \mathbb{R}^{n \times p}$, $\Gamma \in \mathbb{R}^{q \times p}$, $\gamma \in \mathbb{R}^{1 \times q}$, $\Lambda \in \mathbb{R}^{q \times q}$ and $\lambda \in \mathbb{R}$.

By following the same steps as in the previous section, the state and UI reconstruction errors are expressed ; we get from equation (15) with the time operator q :

$$\hat{\eta}_k = (q - \lambda)^{-1} \gamma z_k \quad (16)$$

$$(qI_q - \Lambda)z_k = \Gamma \tilde{y}_k \quad (17)$$

which leads to :

$$[(qI_q - \Lambda) + \Gamma e (q - \lambda)^{-1} q^{-1} \gamma] z_k = \Gamma C \tilde{x}_k + \Gamma e q^{-1} \eta_k \quad (18)$$

The state error dynamics is obtained from (13) and (14) :

$$\begin{aligned} \tilde{x}_{k+1} &= \bar{A} \tilde{x}_k + \bar{D} \tilde{\eta}_{k-1} \\ \bar{A} &= A - KC \\ \bar{D} &= D - Ke \end{aligned} \quad (19)$$

That gives the state estimation error :

$$\tilde{x}_k = (qI_n - \bar{A})^{-1} \bar{D} q^{-1} \eta_k - (qI_n - \bar{A})^{-1} \bar{D} q^{-1} (q - \lambda)^{-1} \gamma z_k \quad (20)$$

By replacing this expression in (18), we have :

$$z_k = \bar{Z}^{-1} \bar{\Lambda} \eta_k \quad (21)$$

with :

$$\begin{aligned} \bar{\Lambda} &= \Gamma C (qI_n - \bar{A})^{-1} \bar{D} + \Gamma e \\ \bar{Z} &= q (qI_q - \Lambda) + \bar{\Lambda} (q - \lambda)^{-1} \gamma \end{aligned} \quad (22)$$

Finally, replacing (21) in (16) and (20) leads to :

$$\begin{cases} \hat{\eta}_k = (q - \lambda)^{-1} \gamma \bar{Z}^{-1} \bar{\Lambda} \eta_k \\ \tilde{x}_k = (qI_n - \bar{A})^{-1} \bar{D} q^{-1} \left[1 - (q - \lambda)^{-1} \gamma \bar{Z}^{-1} \bar{\Lambda} \right] \eta_k \end{cases} \quad (23)$$

The UI estimation error becomes :

$$\tilde{\eta}_k = \left[1 - (q - \lambda)^{-1} \gamma \bar{Z}^{-1} \bar{\Lambda} \right] \eta_k$$

From (23) the state estimation error decoupling condition from the UI can be written as :

$$(qI_n - \bar{A})^{-1} \bar{D} q^{-1} \left[1 - (q - \lambda)^{-1} \gamma \bar{Z}^{-1} \bar{\Lambda} \right] \eta_k = 0 \quad (24)$$

In order to decouple the state from the UI and assure its exact estimation, the following condition has to be verified :

$$\left[1 - (q - \lambda)^{-1} \gamma \bar{Z}^{-1} \bar{\Lambda} \right] \eta_k = 0 \quad (25)$$

Equation (25) may be extended as $\frac{N(q)}{D(q)} \eta_k = 0$. Solving this last equation gives roots defining the UI class that ensure an exact decoupling of the estimation error from the UI. This class is written as : $\sum_i A_i \lambda_i$ where the λ_i correspond to the roots of (25) and A_i are totally free parameters.

IV. PARTIAL DECOUPLING OBSERVER

In the previous section, was detailed how to find the class of UI ensuring an exact decoupling of the UI in respect to the state estimation error. In the following section, a general case with an UI that does not satisfy the decoupling condition is considered. In this case, the problem is solved by attenuating the effect (transfer) of the UI to the estimation error and propose linear matrix inequalities to determinate the observer gain so that the estimated state asymptotically tends to the real one.

In addition to the two previous cases (exact and partial decoupling), we also have a third one, which is a mix between the two solutions. In fact, any UI may be decomposed into a sum of two terms $\eta_k = \eta_k^d + \eta_k^a$. The first term corresponds to the exact decoupling term obtained as explain in section III, and the second one is the approximaion term onto \mathcal{L}_2 attenuation is applied. In subsection A, we only present the attenuation approach; but, in the simulation section the combined approach will be illustrated.

A. \mathcal{L}_2 Attenuation

System and observer equations are given by :

$$\begin{cases} \tilde{x}_{k+1} = \bar{A} \tilde{x}_k + \bar{D} \tilde{\eta}_{k-1} \\ \tilde{\eta}_k = \eta_k - \lambda \eta_{k-1} - \gamma z_{k-1} + \lambda \tilde{\eta}_{k-1} \\ z_{k+1} = \Gamma C \tilde{x}_k + \Gamma e \tilde{\eta}_{k-1} + \Lambda z_k \end{cases} \quad (26)$$

The corresponding matrix form is given by :

$$e_{k+1} = A_1 e_k + B_1 \eta_k^a \quad (27)$$

with :

$$\begin{aligned} A_1 &= \begin{bmatrix} \bar{A} & \bar{D} & 0 & 0 \\ 0 & \lambda & 0 & -\gamma \\ \Gamma C & \Gamma e & \Lambda & 0 \\ 0 & 0 & 1 & 0 \end{bmatrix} & B_1 &= \begin{bmatrix} 0 & 0 \\ 1 & -\lambda \\ 0 & 0 \\ 0 & 0 \end{bmatrix}, \\ e_k &= \begin{bmatrix} \tilde{x}_k \\ \tilde{\eta}_{k-1} \\ z_k \\ z_{k-1} \end{bmatrix} & \eta_k^a &= \begin{bmatrix} \eta_k \\ \eta_{k-1} \end{bmatrix} \end{aligned} \quad (28)$$

In particular, (27) gives the UI influence on the estimation errors. To focus on the impact of the UI on the state estimation \tilde{x}_k , a new observer output is considered :

$$g_k = C_1 e_k \quad (29)$$

with : $C_1 = (I \ 0 \ 0 \ 0)$.

Considering the Real Bounded Lemma [2], the system (27) is stable and the \mathcal{L}_2 gain from η_k^a to g_k is bounded by $\frac{\|g_k\|_2}{\|\eta_k^a\|_2} < \mu$ if there exists a positive symmetric matrix P and a positive scalar μ such that the following condition holds :

$$\begin{bmatrix} A_1^T P A_1 - P & A_1^T P B_1 & C_1^T \\ B_1^T P A_1 & B_1^T P B_1 - \mu^2 I & 0 \\ C_1 & 0 & -\mu^2 I \end{bmatrix} < 0 \quad (30)$$

According to [8] and [18], the previous problem can be reformulated by searching a positive symmetric definite matrix P , gains K and G such that :

$$\begin{bmatrix} -P & A_1^T P B_1 & C_1^T & A_1^T G^T \\ B_1^T P A_1 & B_1^T P B_1 - \mu^2 I & 0 & 0 \\ C_1 & 0 & -\mu^2 I & 0 \\ G A_1 & 0 & 0 & -G - G^T + P \end{bmatrix} < 0 \quad (31)$$

where A_1 defined in (28) with the help of (19), depends on K . Due to this dependence, let us remark that inequality (31) is not linear. For that reason some transformations are needed to obtain LMIs.

Let us write the matrix A_1 such that :

$$A_1 = \bar{A}_1 - R K \bar{B}_1 \quad (32)$$

with :

$$\bar{A}_1 = \begin{bmatrix} A & D & 0 & 0 \\ 0 & \lambda & 0 & -\gamma \\ \Gamma C & \Gamma e & \Lambda & 0 \\ 0 & 0 & 1 & 0 \end{bmatrix} \quad R = \begin{bmatrix} I \\ 0 \\ 0 \\ 0 \end{bmatrix} \quad \bar{B}_1 = [C \ e \ 0 \ 0] \quad (33)$$

Replacing A_1 by (32) in (31), we have :

$$\begin{bmatrix} -P & \bar{A}_1^T P B_1 & C_1^T & \bar{A}_1^T G^T \\ B_1^T P \bar{A}_1 & B_1^T P B_1 - \bar{\mu} I & 0 & 0 \\ C_1 & 0 & -\bar{\mu} I & 0 \\ \bar{G} \bar{A}_1 & 0 & 0 & P - G - G^T \end{bmatrix} + M^T N + N^T M < 0 \quad (34)$$

$$\text{with } M = \begin{bmatrix} -\bar{B}_1^T K^T \\ 0 \\ 0 \\ 0 \end{bmatrix}^T, N = \begin{bmatrix} 0 \\ B_1^T P R \\ 0 \\ G R \end{bmatrix}^T \text{ and } \bar{\mu} = \mu^2$$

Let us recall the following lemma [23]. Consider two real matrices Π and Λ with appropriate dimensions, for any positive matrix Σ the following inequality holds :

$$\Pi^T \Lambda + \Lambda^T \Pi \leq \Pi^T \Sigma \Pi + \Lambda^T \Sigma^{-1} \Lambda \quad (35)$$

Applying this lemma, (34) becomes :

$$\begin{bmatrix} -P & \bar{A}_1^T P B_1 & C_1^T & \bar{A}_1^T G^T \\ B_1^T P \bar{A}_1 & B_1^T P B_1 - \bar{\mu} I & 0 & 0 \\ C_1 & 0 & -\bar{\mu} I & 0 \\ \bar{G} \bar{A}_1 & 0 & 0 & P - G - G^T \end{bmatrix} + M^T \Sigma M + N^T \Sigma^{-1} N < 0 \quad (36)$$

Applying Schur's complement, we get :

$$\begin{bmatrix} -P & \bar{A}_1^T P B_1 & C_1^T & \bar{A}_1^T G^T & \bar{B}_1^T K^T & 0 \\ B_1^T P & B_1^T P B_1 - \bar{\mu} I & 0 & 0 & 0 & B_1^T P R \\ C_1 & 0 & -\bar{\mu} I & 0 & 0 & 0 \\ \bar{G} \bar{A}_1 & 0 & 0 & -G - G^T + P & 0 & G R \\ K \bar{B}_1 & 0 & 0 & 0 & -\Sigma^{-1} & 0 \\ 0 & R^T P B_1 & 0 & R^T G^T & 0 & -\Sigma \end{bmatrix} < 0 \quad (37)$$

At last, by congruence, (37) becomes :

$$\begin{bmatrix} -P & \bar{A}_1^T P B_1 & C_1^T & \bar{A}_1^T G^T & \bar{B}_1^T F^T & 0 \\ B_1^T P & B_1^T P B_1 - \bar{\mu} I & 0 & 0 & 0 & B_1^T P R \\ C_1 & 0 & -\bar{\mu} I & 0 & 0 & 0 \\ \bar{G} \bar{A}_1 & 0 & 0 & -G - G^T + P & 0 & G R \\ F \bar{B}_1 & 0 & 0 & 0 & -\Sigma^T & 0 \\ 0 & R^T P B_1 & 0 & R^T G^T & 0 & -\Sigma \end{bmatrix} < 0 \quad (38)$$

with $F = \Sigma K$. The LMI must be solved in respect to P , G , F and the gain K is obtained by $K = \Sigma^{-1} F$.

B. Pole Assignment

The minimization of the attenuation factor μ may result in slow dynamics of the state estimation error. This problem can be solved by pole assignment of the closed loop system in a specified region. The considered region is a disk centred at $(q, 0)$ with radius α . Thus, the condition to answer this constraint is given by the following : find $P = P^T > 0$ and $Q = Q^T > 0$ such that the following LMI [5] holds :

$$\begin{bmatrix} -\alpha Q & -qQ + Q A_1 - G C \\ (-qQ + Q A_1 - G C)^T & -\alpha P \end{bmatrix} < 0 \quad (39)$$

with $G = QK$. We have to solve this LMI regarding to Q and G then we deduce K . Thus, to ensure the stability and pole assignment, the conditions (38) and (39) must be fulfilled simultaneously.

C. Gain Ajustement

From matrices F and G definitions, there is a dependence between the two LMIs (38) and (39). Then we have to solve simultaneously these two LMIs which can be noted $LMI1(P, K)$ and $LMI2(Q, K)$. The proposed method is based on an ajustment technique allowing to set some variables and calculate others in an iterative way. More precisely, if the gain K is fixed, we solve $LMI1(P, K)$ regarding to P . Then we solve $LMI2(Q, K)$ regarding to Q and K and use the obtained result K for the next iteration (see table 1). This procedure was chosen in reason of its simplicity, but one should be aware that no optimality or convergence guarantee is given. However, since our study goal is to find a solution to the given conditions, an optimal solution is not a necessity.

Iterative optimisation for gain K :

- 1) Set $i = 0$. Choose a stabilisable value K_0 . Put $K^{(i)} = K_0$.
- 2) \mathcal{L}_2 attenuation : Find $P^{(i+1)} > 0$ solution of $LMI1(P, K^{(i)})$.
- 3) Pole assignment : Find $Q^{(i+1)}$ and $K^{(i+1)}$ solution of $LMI2(Q, K)$.
- 4) Stopping condition :
 - If $\|K^{(i+1)} - K^{(i)}\| < \varepsilon$ stop the algorithm : $K_{final} = K^{(i+1)}$.
 - Else, set $i = i + 1$ and go back to step 2.

Table1 : Adjustment algorithm

V. SIMULATIONS

Consider the system (13) described by :

$$A = \begin{bmatrix} 0.6 & -0.2 & -0.1 & 0.1 & 0 \\ -0.1 & 0.7 & -0.1 & 0.1 & -0.1 \\ 0.4 & 0 & 0.9 & 0.5 & -0.3 \\ 0 & 0.2 & 0 & 0.8 & -0.2 \\ -0.1 & 0.2 & 0 & 0 & 0.5 \end{bmatrix} D = \begin{bmatrix} 0.2 \\ -0.3 \\ 0.1 \\ 0.1 \\ 0.2 \end{bmatrix}$$

$$C = \begin{bmatrix} 1 & 0 & 0 & 1 & 0 \\ 0 & 0 & 0 & 0 & 1 \\ 0 & 1 & 1 & 0 & 0 \end{bmatrix} B = \begin{bmatrix} -0.3 & -0.4 \\ 0.5 & -0.4 \\ -0.1 & 0.6 \\ -0.2 & 0.7 \\ 0.2 & 0.1 \end{bmatrix} e = \begin{bmatrix} -1.5 \\ -1.5 \\ -1.5 \end{bmatrix}$$

with the observer parameters :

$$\Lambda = 0.33 \begin{bmatrix} 1 & 1 & 1 \\ 0 & 1 & 1 \\ 0 & 1 & 1 \end{bmatrix} \lambda = 0.7$$

$$\Gamma = 0.2 I_3 \quad \gamma = -0.4 [1 \ 1 \ 1]$$

At the first step, let us determine the observer gain K with the proposed iterative algorithm. The obtained gain K and attenuation μ for a pole assignment in a disk centred at $(0.3, 0)$ with radius 0.2 are :

$$K = \begin{bmatrix} 0.0662 & 0.3073 & -0.0162 \\ 0.3557 & -0.6401 & -0.2057 \\ -0.3790 & 0.8853 & 0.8290 \\ 0.5571 & -0.2525 & -0.2071 \\ -0.0666 & 0.6001 & 0.1166 \end{bmatrix} \mu = 24.09 \quad (40)$$

The second step consists of finding the UI class for an exact decoupling. Let us recall that the state decoupling condition from the UI with its exact estimation of the UI is given by (25). In this example, it corresponds to an UI composed of a linear combination of seven exponential functions : two roots of (25) are complex conjugate and the others have real values given by :

$$\lambda_1 = 1; \lambda_2 = 0.7; \lambda_3 = 0.83; \lambda_4 = 0.15; \lambda_5 = 0.5$$

$$\lambda_{6,7} = 0.085 \pm 0.23i$$

Then, the class of UI for an exact decoupling is given by :

$$\eta_k^d = A_1 \lambda_1^k + A_2 \lambda_2^k + A_3 \lambda_3^k + A_4 \lambda_4^k + A_5 \lambda_5^k + A_6 a^k \cos(\phi k + \psi) \quad (41)$$

with :

$$a = \sqrt{Re(\lambda_6)^2 + Im(\lambda_6)^2} \text{ and } \cos(\phi) = \frac{Re(\lambda_6)^2}{2\sqrt{Re(\lambda_6)^2 + Im(\lambda_6)^2}}$$

The UI is defined by :

$$\eta_k = 0.1 - 0.1(0.7)^k - 0.5(0.83)^k + 0.3(0.15)^k - 0.4(0.5)^k + 0.4(0.47)^k \cos(1.78k) \quad (42)$$

Finally, the considered UI η_k can be written as $\eta_k = \eta_k^d + \eta_k^a$ where η_k^d corresponds to the UI for exact decoupling and η_k^a to the approximation error. The following figures are obtained for the initial conditions $x_0 = (0.5 \ 0.1 \ 0.2 \ -0.1 \ 0)^T$ and $\hat{x}_0 = (-0.5 \ 0.5 \ -0.4 \ 0.2 \ 0.2)^T$. Fig.1 shows the system inputs. Fig.2 represents the UIs (for the exact $\eta_k = \eta_k^d$ and partial decoupling cases $\eta_k = \eta_k^d + \eta_k^a$) and their estimates and Fig 3. represents the system state and their estimate for both situations of exact and partial decoupling. In both situations, the state estimation is satisfactory.

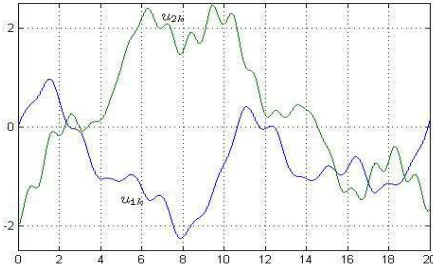

Fig. 1. System inputs

Solving the LMIs (38) may cause slow dynamics of the observer, so an eigenvalue assignment in a D -region allows to increase the performances of the observer.

VI. RESIDUAL GENERATOR DESIGN

The residual generator design is addressed in this section. Based on the system structure, a bank of observers is then designed using the developed UIO in order to detect and isolate a sensor fault through the estimation of system outputs using measurable signals and the model of the system. The procedure is performed by analysing the time-evolution of the residual signals obtained by the comparison between the

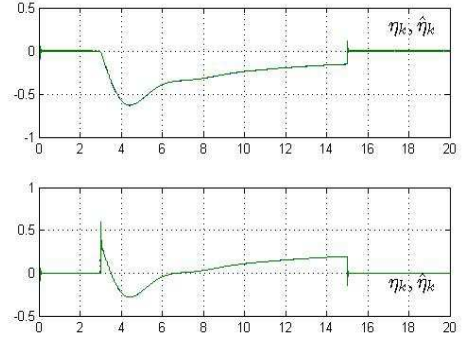

Fig. 2. UI and its estimate

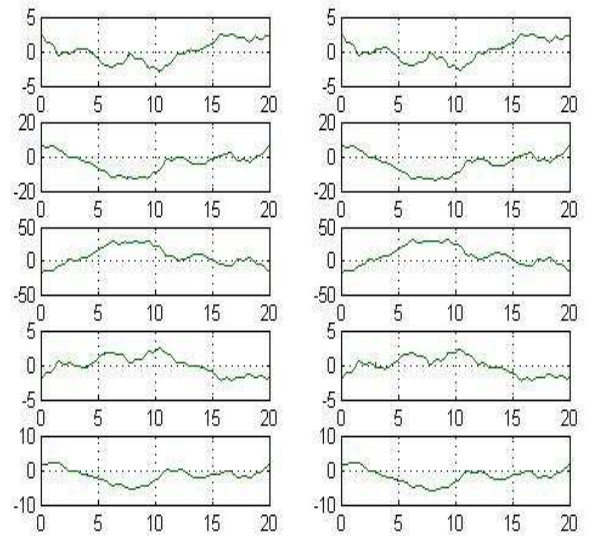

Fig. 3. System states and their estimates : exact decoupling (left) \mathcal{L}_2 -attenuation (right)

measured outputs and the estimated outputs [17] [7]. A GOS structure for the observer bank is adopted (Fig.4).

In theory, the residual signals (i.e. the output estimation error) are null under normal operating conditions of the system. The residual signal structuring, in order to generate appropriated fault indicators, can be obtained by replacing the use of only one observer by the use of a bank of observers where each observer is driven by a partial set of the available signals.

Let us consider the case of a sensor fault occurring at the first sensor of magnitude 1 in the time interval $t \in [8, 15]$. For the simulation, a normally distributed noise of standard deviation equal to 0.1 is added to all the outputs whose magnitudes are varying between -5 and 8 . The first row of Fig.5 represents the residuals under normal operating conditions with measurement noise.

A fault signature localization method had been considered. By comparing the theoretical study (truth table) [17] [7] and the obtained residues (simulations), the faults susceptible to

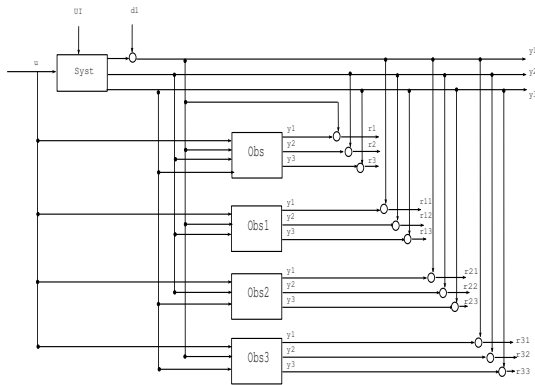

Fig. 4. GOS Structure

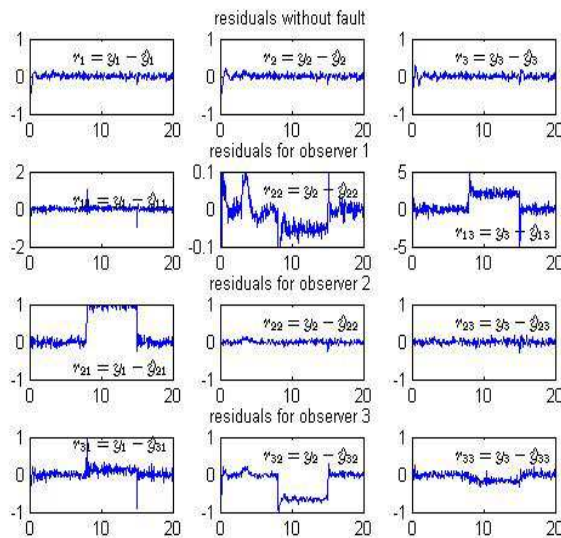

Fig. 5. Residues of the bank observer

be at the origin of the observed symptoms can be isolated (first sensor).

Summarising this section, an observer bank for residual generator was considered. From the obtained results we showed that the previously developed UIO can be used for the detection and isolation of faults when the system is subject to UIs, fault sensors and measurement noise.

VII. CONCLUSION AND PERSPECTIVES

This paper addresses new method to design observers with unknown inputs. The proposed approach is based on a partial decoupling of the state estimation from the UI without any rank constraints on the system matrix. The main result is about the way to find the UI class ensuring an exact decoupling. The proposed work can be extended to the nonlinear case, in particular, systems with Takagi-Sugeno representation.

REFERENCES

- [1] G. Basile and J. Marro, On the observability of linear, time-invariant systems with unknown inputs, *Journal of optimization Theory and applications*, vol. 3, 1969, pp 410-415.
- [2] S. Boyd, L. El Ghaoui, E. Feron and V. Balakrishnan, *Matrix Inequalities in System and Control Theory*, SIAM ed; 1994.
- [3] S-K Chang, Design of General Structured Observers for Linear Systems with Unknown Inputs, *Journal Franklin Institute*, vol. 334 (2), 1997, pp 213-232.
- [4] J. Chen and H. Zhang, Robust detection of faulty actuators via unknown input observers, *International Journal of Systems Science*, vol. 22 (10), 1991, pp 1829-1839.
- [5] M. Chilali and P. Gahinet, H_∞ design with pole placement constraints : an LMI approach, *IEEE Transactions on Automatic Control*, vol. 29 (7), 2010, pp 603-614.
- [6] M. Darouach, M. Zasadzinski and S. Xu, Full-order observers for linear systems with unknown inputs, *IEEE Transactions on Automatic Control*, vol. 39 (3), 1994, pp 606-609.
- [7] S.X. Ding, *Model-Based Fault Diagnosis Techniques Design Schemes, Algorithms and Tools*, 2008, Springer-Verlag.
- [8] M.C. de Oliveira, J. Bernussou and J.C. Geromel, A new discrete-time robust stability condition, *Systems and Control Letters*, vol. 37, 1999, pp 261-265.
- [9] R. Guidorzi and G. Marro, On Wonham stabilizability condition in the synthesis of observers for unknown input systems, *IEEE Transactions on Automatic Control*, vol. 16, 1971, pp 499-500.
- [10] G. Hostetter and J. Meditch, Observing systems with unmeasurable inputs, *IEEE Transactions on Automatic Control*, vol. 18, 1973, pp 307-308.
- [11] M. Hou and P. Muller, Design of observers for linear systems with unknown inputs, *IEEE Transactions on Automatic Control*, vol. 37 (6), 1992, pp 871-875.
- [12] D. Ichalal, B. Marx, J. Ragot and D. Maquin, "State and unknown input estimation for nonlinear systems described by Takagi-Sugeno models with unmeasurable premise variables", *Proceedings of the 17th Mediterranean Conference on Control and Automation, MED09*, Thessaloniki, Greece, 2009.
- [13] D. Ichalal, B. Marx, J. Ragot and D. Maquin, "Simultaneous state and unknown inputs estimation with PI and PMI observers for Takagi Sugeno model with unmeasurable premise variables", *Proceedings of the 17th Mediterranean Conference on Control and Automation, MED09*, Thessaloniki, Greece, 2009.
- [14] R. Isermann, *Fault-diagnosis systems : An introduction from fault detection to fault tolerance*, 2007, Springer.
- [15] T. Iwasaki and R.E. Skelton, The XY-centring algorithm for the dual LMI problem : a new approach to fixed-order control design, *International Journal of Control*, vol. 62 (6), 1995, pp 1257-1272.
- [16] Y. Lossier, *Ajustement de lois de commande : Application en aéronautique*, PhD Thesis, Ecole Nationale Supérieure de l'Aéronautique et de l'Espace, Mars 2006.
- [17] R. J. Patton, P. Frank, and N. Clark, *Issues of Fault Diagnosis for Dynamic systems*, 2008, Springer-Verlag, 2000.
- [18] D. Peaucelle, D. Arzelier, O. Bachelier and J. Bernussou, A new robust D-stability condition for real convex polytopic uncertainty, *Systems and Control Letters*, vol. 40, 2000, pp 21-30.
- [19] M.A. Rotea and T. Iwasaki, "An alternative to the D-K iteration", *Proceedings of the American Control Conference*, Baltimore, Maryland, USA, June 1994, pp. 53-57.
- [20] A. Shumsky, "Algebraic Approach to the Problem of Fault Accommodation in Nonlinear Systems", *Proceedings of the 17th World Congress The International Federation of Automatic Control*, Seoul, Korea, July 6-11 2008.
- [21] Y. Yamada and S. Hara, An LMI approach to local optimization for constantly scaled H_∞ control problems, *International Journal of Control*, vol. 67 (2), 1987, pp 233-250.
- [22] F. Yang and R. Wilde, Observers for linear systems with unknown inputs, *IEEE Transactions on Automatic Control*, vol. 31 (7), 1988, pp 677-681.
- [23] K. Zhou and P.P. Khargonekar, Robust stabilization of linear systems with norm-bounded time-varying uncertainty, *Systems and Control Letters*, vol. 10 (1), 1988, pp 17-20.