



HAL
open science

State estimation for nonlinear system diagnosis using multiple models. Application to wastewater treatment plants

Anca Maria Nagy Kiss, Benoît Marx, Gilles Mourot, José Ragot

► To cite this version:

Anca Maria Nagy Kiss, Benoît Marx, Gilles Mourot, José Ragot. State estimation for nonlinear system diagnosis using multiple models. Application to wastewater treatment plants. Annual Conference of the European Safety and Reliability Association, ESREL 2011, Sep 2011, Troyes, France. pp.CDROM. hal-00630340

HAL Id: hal-00630340

<https://hal.science/hal-00630340>

Submitted on 26 Nov 2021

HAL is a multi-disciplinary open access archive for the deposit and dissemination of scientific research documents, whether they are published or not. The documents may come from teaching and research institutions in France or abroad, or from public or private research centers.

L'archive ouverte pluridisciplinaire **HAL**, est destinée au dépôt et à la diffusion de documents scientifiques de niveau recherche, publiés ou non, émanant des établissements d'enseignement et de recherche français ou étrangers, des laboratoires publics ou privés.

State estimation for nonlinear system diagnosis using multiple models. Application to wastewater treatment plants

Anca Maria Kiss & Benoît Marx & Gilles Mourot & José Ragot

Centre de Recherche en Automatique de Nancy, UMR 7039 – Nancy-Université, CNRS

2, Avenue de la Forêt de Haye, 54516 Vandœuvre, France

Tel./Fax.: +33(0)3.83.59.56.33 / +33(0)3.83.59.56.44

E-mail: anca-maria.nagy, benoit.marx, gilles.mourot, jose.ragot@ensem.inpl-nancy.fr

ABSTRACT: This article deals with the observer synthesis for uncertain nonlinear systems affected by unknown inputs. In order to design such an observer, the nonlinear system is represented under the multiple model (MM) formulation with unmeasurable premise variables. A proportional integral observer (PIO) is considered and used for fault diagnosis using banks of observer to generate structured residuals. The Lyapunov method, expressed through linear matrix inequality (LMI) formulation, is used to describe the stability analysis and to the observer synthesis. An application to a model of Wastewater Treatment Plant (WWTP) is considered.

1 INTRODUCTION

In the field of the observer/controller synthesis, the extension of linear methods to nonlinear systems is generally a difficult problem. The multiple model (Murray-Smith and Johansen 1997) has received a special attention in the last two decades, in order to overcome this difficulty. Then the MM approach is a mean to deal with nonlinear systems and to design observer for such systems and is a convex combination of linear submodels. In this paper, the multiple model formulation is obtained by applying a method proposed in (Nagy et al. 2010). Only the general steps of this technique are reminded in this paper.

Most of the existing works, dedicated to MM in general and to observer design based on MM in particular, are established for MM with measurable premise variables (inputs/outputs), that represents a simplified situation (Tanaka and Wang 2001), (Marx et al. 2007). The MM under study in this paper is more general and involves unmeasurable premise variables depending on the state variables -frequently met in practical situations- that are not always accessible.

A proportional integral observer approach for uncertain nonlinear systems with unknown inputs presented under a MM form with unmeasurable premise variables is proposed in this paper. The state and unknown input estimation given by this observer is made simultaneously and the influence of the model uncertainties is minimized through a \mathcal{L}_2 gain. The convergence conditions of the state and unknown input estimation errors are expressed through LMIs (Linear

Matrix Inequalities) (Tanaka and Wang 2001) by using the Lyapunov method and the \mathcal{L}_2 approach.

The variable estimation results are then used for fault diagnosis using banks of observer to generate structured residuals. Several techniques can be used to cope with the fault detection and isolation (FDI) problem, among them observer-based techniques are largely recognized (Patton et al. 2000), (Ding 2008). Observers are employed in a FDI framework in order to provide an estimation of the interesting signals to be monitored e.g. the outputs, the faults, etc. The FDI of the system is carried out by testing the time-evolution of some residual signals provided by the observer. This is realized through a comparison between system extracted signals and estimated signals. Actuator and sensor faults are treated.

Using these theoretical results, the diagnosis is performed for a wastewater treatment process (WWTP) modeled by an ASM1 model (Weijers 2000). The measures used for simulation process are those of the european program benchmark Cost 624. The choice of the known/unknown inputs, the measures and the real conditions is made by taking into account the properties of the Blesbruck treatment station from Luxembourg. The numerical simulation results for the proposed application show good state and unknown inputs estimation performances and allow the sensors and actuators fault detection.

The paper presents, in section 2, the proposed PI observer. Then, the sensor and actuator fault detection and isolation of the WWTP is realized in section 3, where the estimation results are also given.

Notation 1. The symbol $*$ in a block matrix denotes the blocks induced by symmetry. For any square matrix M , $\mathbb{S}(M)$ is defined by $\mathbb{S}(M) = M + M^T$.

2 PROPORTIONAL INTEGRAL OBSERVER

2.1 Modelling nonlinear systems

Generally, a nonlinear system is given under the following state representation:

$$\dot{x}(t) = f(x(t), u(t), d(t)) \quad (1a)$$

$$y(t) = Cx(t) + Gd(t) \quad (1b)$$

where $x \in \mathbb{R}^n$ is the state variable, $u \in \mathbb{R}^m$ is the input vector, $d \in \mathbb{R}^q$ is the unknown input, $y \in \mathbb{R}^\ell$ the output vector, $f \in \mathbb{R}^n$ and the matrices C and G are known matrices of appropriate dimensions.

The multiple model structure allows to represent nonlinear dynamic systems (1) into a convex combination of linear submodels as follows:

$$\begin{aligned} \dot{x}(t) = & \sum_{i=1}^r \mu_i(x, u) [(A_i + \Delta A_i(t))x(t) \\ & + (B_i + \Delta B_i(t))u(t) + E_i d(t)] \end{aligned} \quad (2a)$$

$$y(t) = Cx(t) + Gd(t) \quad (2b)$$

the matrices A_i , B_i , E_i , C and G are known real and constant matrices of appropriate dimensions excepted $\Delta A_i(t)$ and $\Delta B_i(t)$, denoting the time varying system uncertainties, that satisfy the following equations ((Marx et al. 2007), (Nagy et al. 2010) and references in)

$$\Delta A_i(t) = M_i^a F_a(t) N_i^a, \quad \text{with } F_a^T(t) F_a(t) \leq I \quad (3a)$$

$$\Delta B_i(t) = M_i^b F_b(t) N_i^b, \quad \text{with } F_b^T(t) F_b(t) \leq I \quad (3b)$$

where both $F_a(t) \in \mathbb{R}^{f_1 \times f_1}$ and $F_b(t) \in \mathbb{R}^{f_2 \times f_2}$ are unknown and time varying. The functions $\mu_i(x, u)$ represent the weights of the linear submodels $\{A_i, B_i, E_i\}$ and they have the following convexity properties:

$$\sum_{i=1}^r \mu_i(x, u) = 1, \quad \mu_i(x, u) \geq 0, \quad \forall (x, u) \in \mathbb{R}^n \times \mathbb{R}^m \quad (4)$$

One can note that the activating functions μ_i depend on the system state that is not available to the measurement.

In the sequel, the following assumption is made:

Assumption 1. The unknown input is constant :

$$\dot{d}(t) = 0 \quad (5)$$

It is well known in proportional integral observer (PIO) design that, although this assumption is needed for the theoretical proof of the estimation error convergence, it can be relaxed in practical applications (Koenig and Mammar 2002). For instance, one will see, in section 3, that good estimation results are obtained even with time varying unknown input.

2.2 Proportional integral observer design

In order to estimate both the system state and the unknown input, the following PIO is proposed:

$$\begin{aligned} \hat{x}(t) = & \sum_{i=1}^r \mu_i(\hat{x}(t), u(t)) (A_i \hat{x}(t) + B_i u(t) + E_i \hat{d}(t) \\ & + L_i^P (y(t) - \hat{y}(t))) \end{aligned} \quad (6a)$$

$$\dot{\hat{d}}(t) = \sum_{i=1}^r \mu_i(\hat{x}(t), u(t)) L_i^I (y(t) - \hat{y}(t)) \quad (6b)$$

$$\hat{y}(t) = C \hat{x}(t) + G \hat{d}(t) \quad (6c)$$

The observer design reduces to finding the gains L_i^P and L_i^I such that the state and unknown input estimation error obey to a stable generating system.

Theorem 1. The observer (6) estimating the state and unknown input of the system (2) and minimizing the \mathcal{L}_2 -gain γ of the known and unknown inputs on the state and unknown input estimation error is obtained by finding symmetric positive definite matrices $P_1 \in \mathbb{R}^{(n+n_d) \times (n+n_d)}$ and $P_2 \in \mathbb{R}^{n \times n}$, matrices $\bar{P}_j \in \mathbb{R}^{(n+n_d) \times n_y}$ and positive scalars ε_{1i} and ε_{2i} that minimize the scalar $\bar{\gamma}$ under the following LMI constraints

$$\mathcal{M}_{ij} < 0, \quad i, j = 1, \dots, r \quad (7)$$

where \mathcal{M}_{ij} is defined by

$$\mathcal{M}_{ij} = \begin{bmatrix} \Phi_{ij}^{11} & \Phi_{ij}^{12} & 0 & \Phi_{ij}^{14} & P_1 \bar{M}_i^a & P_1 \bar{M}_i^b \\ * & \Phi_{ij}^{22} & P_2 B_i & P_2 E_i & P_2 M_i^a & P_2 M_i^b \\ * & * & \Phi_{ij}^{33} & 0 & 0 & 0 \\ * & * & * & -\bar{\gamma} I_{n_d} & 0 & 0 \\ * & * & * & * & -\varepsilon_{1i} I_{f_1} & 0 \\ * & * & * & * & * & -\varepsilon_{2i} I_{f_2} \end{bmatrix} \quad (8)$$

with

$$\Phi_{ij}^{11} = I_{n+n_d} + \mathbb{S}(P_1 \bar{A}_j - \bar{P}_j \bar{C}), \quad \Phi_{ij}^{12} = P_1 (\bar{A}_i - \bar{A}_j),$$

$$\Phi_{ij}^{14} = P_1 (\bar{E}_i - \bar{E}_j),$$

$$\Phi_{ij}^{22} = \varepsilon_{1i} N_i^{aT} N_i^a + \mathbb{S}(P_2 A_i), \quad \Phi_{ij}^{33} = \varepsilon_{2i} N_i^{bT} N_i^b - \bar{\gamma} I_{n_u}$$

The overlined and tilded matrices are defined by

$$\bar{C} = [C \ G], \bar{A}_i = \begin{bmatrix} A_i & E_i \\ 0 & 0 \end{bmatrix}, \tilde{A}_i = \begin{bmatrix} A_i \\ 0 \end{bmatrix},$$

$$\tilde{E}_i = \begin{bmatrix} E_i \\ 0 \end{bmatrix}, \bar{M}_i^a = \begin{bmatrix} M_i^a \\ 0 \end{bmatrix}, \bar{M}_i^b = \begin{bmatrix} M_i^b \\ 0 \end{bmatrix}$$

The observer gains are then obtained by:

$$L_j = \begin{bmatrix} L_j^P \\ L_j^I \end{bmatrix} = P_1^{-1} \bar{P}_j$$

Proof. Let us define an augmented state and its estimate by $x_a(t) = \begin{bmatrix} x(t) \\ d(t) \end{bmatrix}$ and $\hat{x}_a(t) = \begin{bmatrix} \hat{x}(t) \\ \hat{d}(t) \end{bmatrix}$ respectively. The augmented state estimation error is defined by $e_a(t) = x_a(t) - \hat{x}_a(t)$. Using (2a) and (5), the system and observer equations can be respectively written as

$$\begin{aligned} \dot{x}_a(t) &= \sum_{i=1}^r \mu_i(x_a(t), u(t)) [(\bar{A}_i + \bar{\Delta A}_i(t))x_a(t) \\ &\quad + (\bar{B}_i + \bar{\Delta B}_i(t))u(t)] \end{aligned} \quad (9a)$$

$$y(t) = \bar{C}x_a(t) \quad (9b)$$

with :

$$\bar{B}_i = \begin{bmatrix} B_i \\ 0 \end{bmatrix}, \quad \bar{\Delta A}_i(t) = \bar{M}_i^a F^a(t) \bar{N}_i^a, \quad \bar{N}_i^{aT} = \begin{bmatrix} N_i^{aT} \\ 0 \end{bmatrix},$$

$$\bar{\Delta B}_i(t) = \bar{M}_i^b F^b(t) \bar{N}_i^b, \quad \bar{N}_i^{bT} = \begin{bmatrix} N_i^{bT} \\ 0 \end{bmatrix} \quad (10)$$

and

$$\begin{aligned} \dot{\hat{x}}_a(t) &= \sum_{j=1}^r \mu_j(\hat{x}_a(t), u(t)) [\bar{A}_j \hat{x}_a(t) + \bar{B}_j u(t) \\ &\quad + L_j (y(t) - \hat{y}(t))] \end{aligned} \quad (11a)$$

$$\hat{y}(t) = \bar{C} \hat{x}_a(t) \quad (11b)$$

One should note that in (9) the activating functions depend on $x_a(t)$, whereas they depend on $\hat{x}_a(t)$ in (11) and then the comparison of the state x_a (9a) and its reconstruction (11a) seems to be difficult. In order to cope with the difficulty of expressing the augmented state estimation error in a tractable way, (9a) is rewritten, based on the property (4). Consequently, the augmented state estimation error obeys to the following nonlinear system

$$\begin{aligned} \begin{bmatrix} \dot{e}_a(t) \\ \dot{\hat{x}}(t) \end{bmatrix} &= \sum_{i=1}^r \sum_{j=1}^r \mu_i(x_a(t), u(t)) \mu_j(\hat{x}_a(t), u(t)) \\ &\quad \left\{ \begin{bmatrix} \bar{A}_j - \bar{L}_j \bar{C} & \tilde{A}_i - \tilde{A}_j + \tilde{\Delta A}_i(t) \\ 0 & A_i + \Delta A_i(t) \end{bmatrix} \begin{bmatrix} e_a(t) \\ x(t) \end{bmatrix} \right. \\ &\quad \left. + \begin{bmatrix} \bar{\Delta B}_i(t) & \tilde{E}_i - \tilde{E}_j \\ B_i + \Delta B_i(t) & E_i \end{bmatrix} \begin{bmatrix} u(t) \\ d(t) \end{bmatrix} \right\} \end{aligned} \quad (12a)$$

$$e_a(t) = \begin{bmatrix} I_{n+n_d} & 0 \end{bmatrix} \begin{bmatrix} e_a(t) \\ x(t) \end{bmatrix} \quad (12b)$$

where

$$\tilde{\Delta A}_i(t) = \begin{bmatrix} \Delta A_i(t) \\ 0 \end{bmatrix} \quad (13)$$

The candidate Lyapunov function for (12) is

$$V(x_a(t), x(t)) = \begin{bmatrix} e_a(t) \\ x(t) \end{bmatrix}^T \begin{bmatrix} P_1 & 0 \\ 0 & P_2 \end{bmatrix} \begin{bmatrix} e_a(t) \\ x(t) \end{bmatrix} \quad (14)$$

where P_1 and P_2 are symmetric positive definite matrices. The objective is to find the gains \bar{L}_j of the observer that minimize the \mathcal{L}_2 -gain from the known and unknown inputs $u(t)$ and $d(t)$ to the state and fault estimation error $e_a(t)$. It is well known (Boyd et al. 1994) that the \mathcal{L}_2 -gain from $\begin{bmatrix} u(t) \\ d(t) \end{bmatrix}$ to $e_a(t)$ is bounded by γ if

$$\dot{V}(e_a(t), x(t)) + e_a^T(t) e_a(t) - \gamma^2 (u^T(t) u(t) + d^T(t) d(t)) < 0 \quad (15)$$

With some Schur complements and defining $\bar{P}_j = P_1 \bar{L}_j$ and $\bar{\gamma} = \gamma^2$, the previous inequality becomes

$$\sum_{i=1}^r \sum_{j=1}^r \mu_i(x_a(t)) \mu_j(\hat{x}_a(t)) \mathcal{M}_{ij} < 0 \quad (16)$$

It follows that (15) is satisfied if the LMI (7) holds, which achieves the proof. \square

3 DIAGNOSIS FOR WASTEWATER TREATMENT PLANT

3.1 Diagnosis based on bank observers

In this section the PI observer is used to perform fault diagnosis, which consists in generating residuals based on redundancy principle. In this context, the comparison between output measured signals and estimated output signals - by using an observer- is done. The residual, that is the difference between these two signals, must, therefore, be different from zero when a fault occurs and zero otherwise. However, the deviation between the model and the plant is influenced not

only by the presence of the fault but also by the modeling error, noise or other perturbations. Thus, some detection thresholds are fixed in order to avoid false alarms, these thresholds being fixed by taking into account the modeling error range.

A residual structuration is often needed in order to efficiently realize the fault detection and isolation. This task consists in constructing residuals so that each one is sensitive to a known subset of faults and insensitive to the others. In order to do this, a bank of observers will be used, each one using a part of available information of the system.

Sensor fault detection

In this case, the output of the system has the form:

$$y(t) = Cx(t) + Du(t) + \delta(t)$$

where $\delta(t)$ is a sensor fault vector. An intermediate observer scheme -derived from the Dedicated Observer Scheme (DOS) (Patton et al. 2000)- is used for residual structuring. This scheme uses two outputs among ℓ outputs of the system (see figure 1 for $\ell = 4$). In general, the acronym *PIO ij* means a proportional integral observer of the form (6) that uses only the outputs i and j in state estimation process. The residuals are defined by:

$$r_{i,j}(t) = y_i(t) - \hat{y}_{i,j}(t), \quad i = 1, \dots, \ell, \quad j \in I_{Obs} \quad (17)$$

where the index i refers the outputs and the index j indicates the observer used to reconstruct the referred outputs. Thus, $y_i(t)$ (resp. $\hat{y}_{i,j}(t)$) is the i^{th} component of $y(t)$ (resp. $\hat{y}_j(t)$ the output estimation delivered by the j^{th} observer) and

$$I_{Obs} = \{12, 13, \dots, 1\ell, 23, 24, \dots, 2\ell, \dots, (\ell - 1)\ell\}$$

Let us define I_i the index set of observers using the output y_i and $I_{\bar{i}}$ the index set of observers that does not uses the output y_i . The following alarms $a_i(t)$ associated to $\delta_i(t)$ for all $i = 1, \dots, \ell$ are defined as:

$$r_{b\ i,j}(t) = \begin{cases} 0, & \text{if } |r_{i,j}(t)| \leq \text{threshold} \\ 1, & \text{if } |r_{i,j}(t)| > \text{threshold} \end{cases} \quad (18a)$$

$$a_i(t) = \prod_{j \in I_{\bar{i}}} \left(r_{b\ i,j}(t) \prod_{\substack{k=1 \\ k \neq j}}^{\ell} \bar{r}_{b\ k,j}(t) \right) \quad (18b)$$

Actuator fault detection

In this case, the state of the system is given by:

$$\dot{x}(t) = \sum_{i=1}^r \mu_i(x(t), u(t) + \eta(t)) [A_i x(t) + B_i(u(t) + \eta(t))] \quad (19)$$

where $\eta(t)$ is an actuator fault vector.

The same principle as previously allows the detection and isolation of the actuator faults. A dedicated observer scheme will be used in this case, where the i^{th}

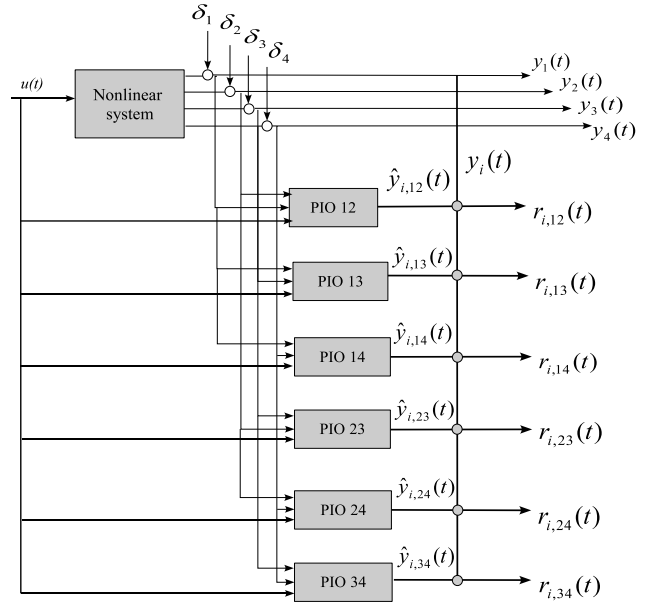

Figure 1: DOS bank observer for sensor fault detection

observer use the i^{th} input and all outputs. The other inputs are considered as unknown input and consequently a bank of PIO is synthesized. The alarms associated to actuator faults can be similarly defined as in (18).

3.2 Process description

The activated sludge wastewater treatment is widely used and studied in the last two decades (Henze et al. 1987), (Alex et al. 1999), (Olsson and Newell 1999), (Smets et al. 2006), (Boukroune 2009). It consists in mixing wastewater with a bacteria mixture in order to degrade the pollutants contained in the water.

The polluted water circulates in an aeration basin in which the bacterial biomass degrades the polluted matter. Micro-organisms gather together in colonial structures called flocs and produce sludges. The mixed liqueur is then sent to a clarifier where the separation of the purified water and the flocs is made by gravity. A fraction of the settled sludges is recycled towards the reactor to maintain its capacity of purification. The purified water is thrown back in the natural environment.

Only a part of the European program Cost 624 Benchmark (Alex et al. 1999) is considered. Usually, a configuration with a single tank with a settler/clarifier is used. The data used for simulation are generated with the complete ASM1 model ($n = 13$) (Henze et al. 1987), in order to represent a realistic behavior of a WWTP. In order to ease the obtaining of the MM representation, the observer design is based on a reduced model ($n = 6$) (Weijers 2000):

$$\begin{aligned} \dot{X}_{DCO}(t) &= -\frac{1}{Y_H} [\varphi_1(t) + \varphi_2(t)] \\ &\quad + (1 - f_P)(\varphi_4(t) + \varphi_5(t)) + D_1(t) \\ \dot{S}_O(t) &= \frac{Y_H - 1}{Y_H} \varphi_1(t) + \frac{Y_A - 4.57}{Y_A} \varphi_3(t) + D_2(t) \end{aligned}$$

$$\begin{aligned}
\dot{S}_{NH}(t) &= -i_{XB}[\varphi_1(t) + \varphi_2(t)] - \left(i_{XB} + \frac{1}{Y_A}\right)\varphi_3(t) \\
&\quad + (i_{XB} - f_P i_{XP})[\varphi_4(t) + \varphi_5(t)] + D_3(t) \\
\dot{S}_{NO}(t) &= \frac{Y_H - 1}{2.86Y_H}\varphi_2(t) + \frac{1}{Y_A}\varphi_3(t) + D_4(t) \\
\dot{X}_{BH}(t) &= \varphi_1(t) + \varphi_2(t) - \varphi_4(t) + D_5(t) \\
\dot{X}_{BA}(t) &= \varphi_3(t) - \varphi_5(t) + D_6(t) \quad (20)
\end{aligned}$$

where the process kinetics $\varphi_i(t)$ ($i = 1, \dots, 5$) and the input/output balances $D_i(t)$ ($i = 1, \dots, 6$) can be found in (Weijers 2000). For limited space reasons, only $\varphi_1(t)$ and $D_1(t)$ are given as follows:

$$\varphi_1(t) = \frac{\mu_H X_{DCO}(t)}{K_{DCO} + X_{DCO}(t)} \frac{S_O(t)}{K_{OH} + S_O(t)} X_{BH}(t) \quad (21)$$

$$D_1(t) = \frac{q_{in}(t)}{V} [X_{DCO,in}(t) - X_{DCO}(t)] \quad (22)$$

The simplified model involves the following six components: the chemical oxygen demand (COD) X_{DCO} , oxygen S_O , heterotrophic biomass X_{BH} , ammonia S_{NH} , nitrate S_{NO} and autotrophic biomass X_{BA} . The inert components (S_I , X_I , X_P) and the alkalinity (S_{alk}) are not considered. The dynamic of the suspended organic nitrogen (X_{ND}) and the ammonia production from organic nitrogen (S_{ND}) is neglected. In conformity with the benchmark of the european program Cost 624 (Alex et al. 1999) and with the real time condition of a wastewater treatment plant - Bleesbruck from Luxembourg- the output vector considered here is:

$$y(t) = [X_{DCO}(t), S_O(t), S_{NH}(t), S_{NO}(t)]^T \quad (23)$$

the known input vector is:

$$u(t) = [X_{DCO,in}(t), q_a(t)]^T \quad (24)$$

and the unknown input vector is:

$$d(t) = [S_{NH,in}(t), X_{BH,in}(t)]^T \quad (25)$$

The variables q_{in} and q_a represent the input and the air flow of the bioreactor. The stoichiometric and growth/decay kinetic parameters are those of (Olsson and Newell 1999).

Multiple model representation

Since the transformation of the nonlinear system (20) into a MM does not constitutes the main objective of the paper, and for lack of space, only the essential points are given in the following. For more details

on this procedure the reader is referred to (Nagy et al. 2010).

Considering the process (20), it is natural to define the following premise variables since they mainly contribute to the definitions of the system nonlinearity:

$$\begin{aligned}
z_1(x, u) &= \frac{q_{in}(t)}{V} \\
z_2(x, u) &= \frac{X_{DCO}(t)}{K_{DCO} + X_{DCO}(t)} \frac{S_O(t)}{K_{OH} + S_O(t)} \\
z_3(x, u) &= \frac{X_{DCO}(t)}{K_{DCO} + X_{DCO}(t)} \frac{S_{NO}(t)}{K_{NO} + S_{NO}(t)} \frac{K_{OH}}{K_{OH} + S_O(t)} \\
z_4(x, u) &= \frac{1}{K_{OA} + S_O(t)} \frac{S_{NH}(t)}{K_{NH,A} + S_{NH}(t)} X_{BA}(t)
\end{aligned} \quad (26)$$

The system (20) can be written in a quasi-LPV form $\dot{x}(t) = A(x, u)x(t) + B(x, u)u(t) + E(x, u)d(t)$ with matrices $A(x, u)$, $B(x, u)$ and $E(x, u)$ expressed by using the premise variables previously defined:

$$\begin{aligned}
A(x, u) &= \begin{bmatrix} a_{11} & 0 & 0 & 0 & a_{15} & a_{16} \\ 0 & a_{22} & 0 & 0 & a_{25} & 0 \\ 0 & a_{32} & -z_1(u) & 0 & a_{35} & a_{36} \\ 0 & a_{42} & 0 & -z_1(u) & a_{45} & 0 \\ 0 & 0 & 0 & 0 & a_{55} & 0 \\ 0 & a_{62} & 0 & 0 & 0 & a_{66} \end{bmatrix} \\
B(u) &= \begin{bmatrix} z_1(u) & 0 \\ 0 & K S_{O,sat} \\ 0 & 0 \\ 0 & 0 \\ 0 & 0 \\ 0 & 0 \end{bmatrix}, \quad E(u) = \begin{bmatrix} 0 & 0 \\ 0 & 0 \\ z_1(u) & 0 \\ 0 & 0 \\ 0 & z_1(u) \\ 0 & 0 \end{bmatrix} \quad (27)
\end{aligned}$$

where:

$$\begin{aligned}
a_{11}(x, u) &= -z_1(x, u) \\
a_{15}(x, u) &= -\frac{\mu_H}{Y_H} z_2(x, u) + (1 - f_P) b_H - \frac{\mu_H \eta_{NOg}}{Y_H} z_3(x, u) \\
a_{16}(x, u) &= (1 - f_P) b_A \\
a_{22}(x, u) &= -z_1(x, u) - K q_a - \frac{4.57 - Y_A}{Y_A} \mu_A z_4(x, u) \\
a_{25}(x, u) &= \frac{(Y_H - 1) \mu_H}{Y_H} z_2(x, u) \\
a_{32}(x, u) &= -(i_{XB} + \frac{1}{Y_A}) \mu_A z_4(x, u) \\
a_{35}(x, u) &= (i_{XB} - f_P i_{XP}) b_H - i_{XB} \mu_H z_2(x, u) \\
&\quad - i_{XB} \mu_H \eta_{NOg} z_3(x, u) \\
a_{36}(x, u) &= (i_{XB} - f_P i_{XP}) b_A \\
a_{42}(x, u) &= \frac{1}{Y_A} \mu_A z_4(x, u) \\
a_{45}(x, u) &= \frac{Y_H - 1}{2.86 Y_H} \mu_H \eta_{NOg} z_3(x, u) \\
a_{55}(x, u) &= \mu_H z_2(x, u) - b_H + z_1(x, u) \left[\frac{f_W(1+f_R)}{f_R+f_W} - 1 \right] \\
&\quad + \mu_H \eta_{NOg} z_3(x, u) \\
a_{62}(x, u) &= \mu_A z_4(x, u) \\
a_{66}(x, u) &= z_1(x, u) \left[\frac{f_W(1+f_R)}{f_R+f_W} - 1 \right] - b_A
\end{aligned}$$

The decomposition of z_j , $j = 1, \dots, 4$ (26) is realized by using the convex polytopic transformation:

$$z_j(x, u) = F_{j,1}(z_j(x, u)) z_{j,1} + F_{j,2}(z_j(x, u)) z_{j,2} \quad (28)$$

The scalars $z_{j,1}$ and $z_{j,2}$ are respectively the minima and the maxima of $z_j(x, u)$ and the functions

$F_{j,1}(z_j(x,u))$ and $F_{j,2}(z_j(x,u))$ are given by:

$$F_{j,1}(z_j(x,u)) = \frac{z_j(x,u) - z_{j,2}}{z_{j,1} - z_{j,2}} \quad (29)$$

$$F_{j,2}(z_j(x,u)) = \frac{z_{j,1} - z_j(x,u)}{z_{j,1} - z_{j,2}} \quad (30)$$

By multiplying the functions $F_{j,\sigma_i^j}(z_j(x,u))$, the $r = 16$ weighting functions $\mu_i(z(x,u))$ ($i = 1, \dots, 16$) are obtained:

$$\mu_i(z) = F_{1,\sigma_i^1}(z_1)F_{2,\sigma_i^2}(z_2)F_{3,\sigma_i^3}(z_3)F_{4,\sigma_i^4}(z_4) \quad (31)$$

The indexes $\sigma_i^j \in \{1,2\}$ and the quadruplets $(\sigma_i^1, \sigma_i^2, \sigma_i^3, \sigma_i^4)$ represent the 16 combinations of indexes 1 and 2. The constant matrices A_i , B_i and E_i defining the 16 submodels, are determined by using the matrices $A(x,u)$, $B(u)$, $E(u)$ and the scalars z_{j,σ_i^j} :

$$A_i = A(z_{1,\sigma_i^1}, z_{2,\sigma_i^2}, z_{3,\sigma_i^3}, z_{4,\sigma_i^4}) \quad (32a)$$

$$B_i = B(z_{1,\sigma_i^1}) \quad (32b)$$

$$E_i = E(z_{1,\sigma_i^1}), \quad i = 1, \dots, 16, \quad j = 1, \dots, 4 \quad (32c)$$

Thus, the nonlinear model (20) is equivalently written under the multiple model form (2), where $\Delta A_i(t) = \Delta B_i(t) = 0$, $i = 1, \dots, 16$.

Uncertainties in the MM form of the ASM1 model

The MM form used for the ASM1 model was previously proposed. In the following, its structure is slightly modified in order to take into account parameter uncertainties on b_H and b_A . These parameters appear in the coefficients a_{15} , a_{16} , a_{35} , a_{36} , a_{55} and a_{66} in (27), allowing to separate the uncertain part $\Delta A(t)$ from the known one $A(t)$ in (27). The parameter variation on b_H (resp. b_A) is of 20% (resp. 25%) of its nominal value, i.e. $b_H \in [0.25 ; 0.35]$ (resp. $b_A \in [0.04 ; 0.06]$) (Chachuat 2001). The uncertainties effect, taken into account in the matrices $A + \Delta A(t)$, can be written as:

$$\Delta A(t) = \begin{bmatrix} 0 & 0 & 0 & 0 & 0.2\Delta b_H(t) & 0.25\Delta b_A(t) \\ 0 & 0 & 0 & 0 & 0 & 0 \\ 0 & 0 & 0 & 0 & 0.2\Delta b_H(t) & 0.25\Delta b_A(t) \\ 0 & 0 & 0 & 0 & 0 & 0 \\ 0 & 0 & 0 & 0 & 0.2\Delta b_H(t) & 0 \\ 0 & 0 & 0 & 0 & 0 & 0.25\Delta b_A(t) \end{bmatrix} \quad (33)$$

Moreover the uncertain term is written under the form $\Delta A(t) = M^a F_a(t) N^a$ with the matrices:

$$M^a = \begin{bmatrix} 0.2 & 0 & 0.2 & 0 & 0.2 & 0 \\ 1 & 0 & 1 & 0 & 0 & 1 \end{bmatrix}^T \quad (34)$$

$$F_a(t) = \begin{bmatrix} \Delta b_H(t) & 0 \\ 0 & \Delta b_A(t) \end{bmatrix} \quad (35)$$

$$N^a = \begin{bmatrix} 0 & 0 & 0 & 0 & 1 & 0 \\ 0 & 0 & 0 & 0 & 0 & 0.25 \end{bmatrix} \quad (36)$$

where $F_a(t)$ has the following property:

$$F_a^T(t)F_a(t) \leq I$$

3.3 Results and discussions

The data used for simulation are generated with the complete ASM1 model ($n = 13$) (Henze et al. 1987), in order to represent a realistic behavior of a WWTP. Even if the observer design is based on a MM form of the reduced ASM1 model ($n = 6$) it will be seen that the estimation results are satisfactory.

Applying the Theorem 1, the observer (6) is designed by finding positive scalars ε_{1i} , ε_{2i} ($i = 1, \dots, 16$), positive definite matrices P_1 and P_2 and matrices \bar{P}_j ($j = 1, \dots, 16$) -that are not given here due to space limitation- such that the convergence conditions, given in Theorem 1 hold. The value of the attenuation rate from the known and unknown inputs $u(t)$ and $d(t)$ to the state and fault estimation error $e_a(t)$ is $\bar{\gamma} = 1.52$. A comparison between the actual state variables, the unknown inputs and their respective estimates is depicted in the figure 2.

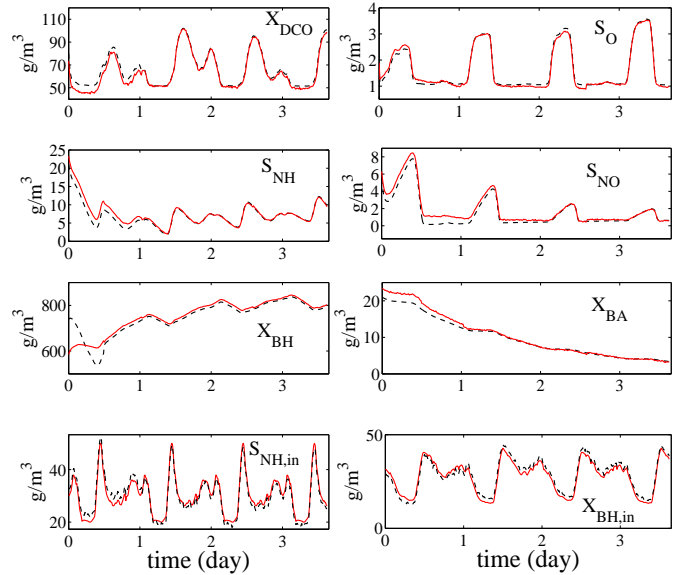

Figure 2: Real state and unknown inputs (dotted line) and their estimations using the PIO (solid line)

In order to diagnose the wastewater treatment plant, the reduced model (20) is used for observer design with the measured outputs defined in (23). Some faults affecting the reactor outputs are simulated as follows:

- δ_1 affects $y_1 = X_{DCO}$ in time period $(0.25; 0.75)[days]$
- δ_2 affects $y_2 = S_O$ in time period $(2.25; 2.75)[days]$
- δ_3 affects $y_3 = S_{NH}$ in time period $(1; 1.5)[days]$
- δ_4 affects $y_4 = S_{NO}$ in time period $(3; 3.25)[days]$

An observer bank with six observers is conceived as in figure 1. The analysis of the configuration of residuals $r_{1,12}, r_{2,12}, \dots, r_{4,34}$ allows the detection and the isolation of sensor faults (see figure 3). These residuals are zero if no fault or noise is present on the sensors. Between $t = 0.25[days]$ et $t = 0.75[days]$, the residuals $r_{j,12}, r_{j,13}$ and $r_{j,14}$ for $j \in I_{obs}$ correspond to the fault free case. This information is confirmed by the residuals generated with the three others observers (*PIO 23*, *PIO 24*, *PIO 34*) that allows the localization of a fault on y_1 . Equivalently, for the time period $(3; 3.25)[days]$, the residuals $r_{j,14}, r_{j,24}$ and $r_{j,34}$ for $j \in I_{obs}$ correspond to the fault free case. This information is confirmed by the residuals generated with the three others observers (*PIO 23*, *PIO 24*, *PIO 34*) that allows the localization of a fault on y_4 , and so on for the other residuals. A signature table allowing to correctly finalize the sensor fault detection and isolation task is given in table 1. A “1” element indicates that $r_{i,j}$ is sensitive to the fault δ_i while “0” indicates that $r_{i,j}$ does not respond to the fault δ_i . Finally, the symbol “?” indicates that no decision can be taken only based on this residual.

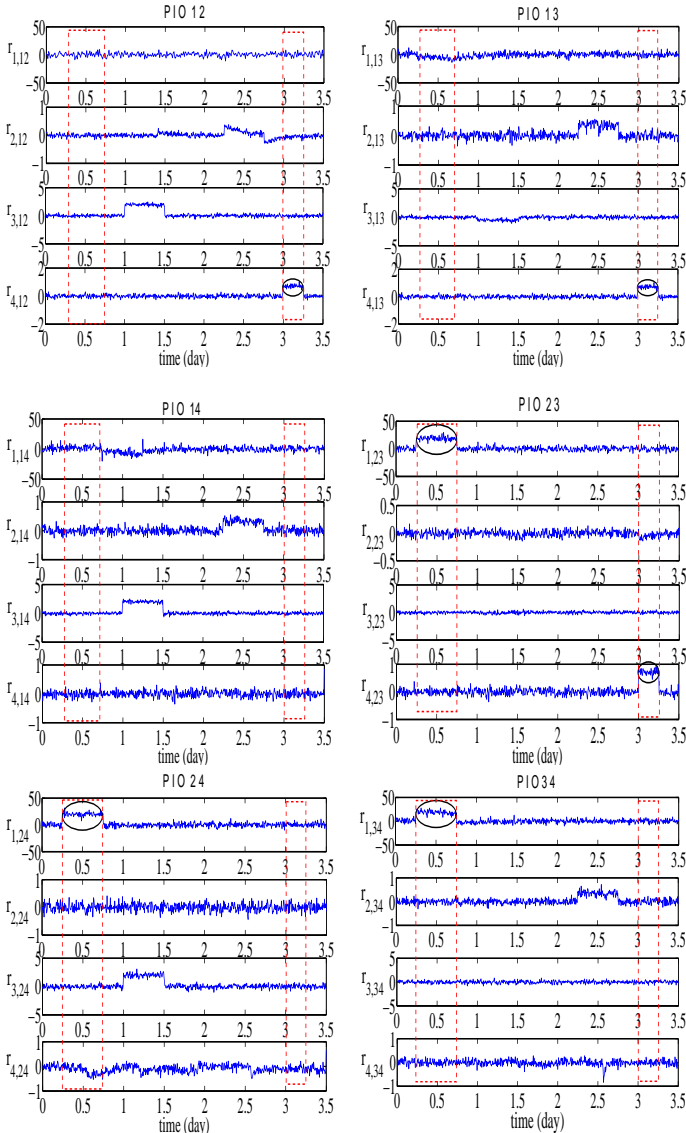

Figure 3: Residuals evolution - GOS for sensor fault detection

Further, the diagnosis technique is applied to detect actuator faults considering the same reduced ASM1 model. Since the control vector is (24) we consider respectively the faults η_1 and η_2 affecting the two actuators, according to:

$$\eta_1(t) = \begin{cases} 0.3X_{DCO,in}(t), & 0.5 < t < 1.0 \\ 0, & \text{otherwise} \end{cases} \quad (37)$$

$$\eta_2(t) = \begin{cases} 0.3q_a(t), & 2.5 < t < 3.0 \\ 0, & \text{otherwise} \end{cases} \quad (38)$$

An observer bank with two PIO is conceived. The residuals are similarly constructed as in (17) for $i = 1, \dots, m$ and $j = 1, \dots, \ell$. Here, $m = 2$ and $\ell = 4$. The analysis of the configuration of residuals $r_{i,j}$ allows the detection and the localization of actuator faults. In figure 4, the residuals $r_{1,1}, r_{2,1}, r_{3,1}$ and $r_{4,1}$ generated with the first observer indicate a fault between the instants $0.5[days]$ and $1.0[days]$ which corresponds to a fault affecting the control $X_{DCO,in}$. The fault affecting q_a is localized when analysing the residuals $r_{1,2}, r_{2,2}, r_{3,2}$ and $r_{4,2}$ given by the second observer. The simulation results correspond to the theoretical signature table 2.

Table 2: Theoretical signatures for actuator fault detection - DOS

	PIO 1				PIO 2			
	$r_{1,1}$	$r_{2,1}$	$r_{3,1}$	$r_{4,1}$	$r_{1,2}$	$r_{2,2}$	$r_{3,2}$	$r_{4,2}$
η_1	1	1	1	1	0	0	0	0
η_2	0	0	0	0	1	1	1	1

4 CONCLUSION

A proportional integral observer adapted to uncertain nonlinear systems affected by unknown inputs is proposed in this paper. The nonlinear system is equivalently represented by a multiple model with unmeasurable premise variables which is not intensively studied in literature because observer design or stability analysis are difficult problems for this kind of systems. An application to diagnosis based on the synthesis of the proposed proportional integral observer is realized. This theoretical points are then applied to a realistic model of a wastewater treatment plant that is characterized by parameter uncertainties and unknown inputs. The numerical simulation results for the proposed application show that sensor and actuator fault detection can be performed as well by using this type of observer.

5 ACKNOWLEDGMENTS

We acknowledge the financial support received from the "Fonds National de la Recherche", Luxembourg. This research is also supported by the TASSILI 07 program under MDU grant 714.

Table 1: Theoretical signature table for sensor fault detection - DOS with 2 outputs among 4

	PIO 12				PIO 13				PIO 14				PIO 23				PIO 24				PIO 34			
	$r_{1,12}$	$r_{2,12}$	$r_{3,12}$	$r_{4,12}$	$r_{1,13}$	$r_{2,13}$	$r_{3,13}$	$r_{4,13}$	$r_{1,14}$	$r_{2,14}$	$r_{3,14}$	$r_{4,14}$	$r_{1,23}$	$r_{2,23}$	$r_{3,23}$	$r_{4,23}$	$r_{1,24}$	$r_{2,24}$	$r_{3,24}$	$r_{4,24}$	$r_{1,34}$	$r_{2,34}$	$r_{3,34}$	$r_{4,34}$
δ_1	?	?	?	?	?	?	?	?	?	?	?	?	1	0	0	0	1	0	0	0	1	0	0	0
δ_2	?	?	?	?	0	1	0	0	0	1	0	0	?	?	?	?	?	?	?	?	0	1	0	0
δ_3	0	0	1	0	?	?	?	?	0	0	1	0	?	?	?	?	0	0	1	0	?	?	?	?
δ_4	0	0	0	1	0	0	0	1	?	?	?	?	0	0	0	1	?	?	?	?	?	?	?	?

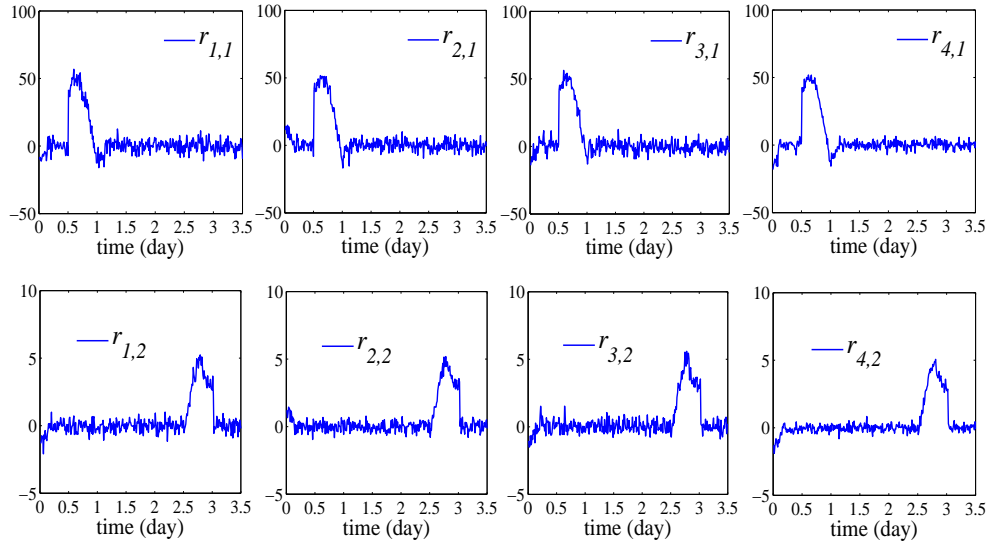

Figure 4: Residual evolution using GOS schema for actuator fault detection

REFERENCES

- Alex, J., J. F. Beteau, J. B. Copp, C. Hellinga, U. Jeppsson, S. Marsili-Libelli, M. N. Pons, H. Spanjers, and H. Vanhooren (1999). Benchmark for evaluating control strategies in wastewater treatment plants. In *European Control Conference*, Karlsruhe, Germany.
- Boukroune, B. (2009). A nonlinear observer design for an activated sludge wastewater treatment process. *Journal of Process Control* 19, 1558–1565.
- Boyd, S., L. El Ghaoui, E. Feron, and V. Balakrishnan (1994). *Linear matrix inequalities in system and control theory*. Philadelphia: Studies in Applied and Numerical Mathematics.
- Chachuat, B. (2001). *Méthodologie d'optimisation dynamique et de commande optimale des petites stations d'épuration à boues activées*. Ph. D. thesis, Institut National Polytechnique de Lorraine, Nancy, France. In French.
- Ding, S. X. (2008). *Model-based Fault Diagnosis Techniques*. Springer-Verlag.
- Henze, M., C. P. Leslie Grady Jr, W. Gujer, G. v. R. Marais, and T. Matsuo (1987). Activated Sludge Model no.1. I.A.W.Q. Scientific and Technical Report No.1. Technical report, I.A.W.Q., London, UK.
- Koenig, D. and S. Mammar (2002). Design of proportional-integral observer for unknown input descriptor systems. *IEEE Transactions on Automatic Control* 47(12), 2057–2062.
- Marx, B., D. Koenig, and J. Ragot (2007). Design of observers for Takagi-Sugeno descriptor systems with unknown inputs and application to fault diagnosis. *IET Control Theory and Applications* 1(5), 1487–1495.
- Murray-Smith, R. and T. A. Johansen (1997). *Multiple model approaches to modeling and control*. Taylor & Francis, London.
- Nagy, A. M., G. Mourot, B. Marx, G. Schutz, and J. Ragot (2010). Systematic multi-modeling methodology applied to an activated sludge reactor model. *Industrial & Engineering Chemistry Research* 49(6), 2790–2799.
- Olsson, G. and B. Newell (1999). *Wastewater Treatment Systems. Modelling, Diagnosis and Control*. IWA Publishing.
- Patton, R. J., P. Frank, and N. Clark (2000). *Issues of Fault Diagnosis for Dynamic systems*. Springer-Verlag.
- Smets, I., L. Verdickt, and J. Van Impe (2006). A linear ASM1 based multi-model for activated sludge systems. *Mathematical and Computer Modeling of Dynamical Systems* 12(5), 489–503.
- Tanaka, K. and H. O. Wang (2001). *Fuzzy Control System Design and analysis. A Linear Matrix Inequality Approach*. John Wiley & Sons Inc.
- Weijers, S. R. (2000). *Modelling, identification and control of activated sludge plants for nitrogen removal*. Ph. D. thesis, Technische Universiteit Eindhoven, Eindhoven.