



HAL
open science

DOUBLE AND SINGLE LAYERS FLUX-SWITCHING PERMANENT MAGNET MOTORS: FAULT TOLERANT MODEL FOR CRITICAL APPLICATIONS

Guangjin Li, Javier Ojeda, Emmanuel Hoang, Mohamed Gabsi

► **To cite this version:**

Guangjin Li, Javier Ojeda, Emmanuel Hoang, Mohamed Gabsi. DOUBLE AND SINGLE LAYERS FLUX-SWITCHING PERMANENT MAGNET MOTORS: FAULT TOLERANT MODEL FOR CRITICAL APPLICATIONS. International Conference on Electrical Machines and Systems 2011, Aug 2011, Beijing, China. pp.1-6. hal-00628851

HAL Id: hal-00628851

<https://hal.science/hal-00628851>

Submitted on 4 Oct 2011

HAL is a multi-disciplinary open access archive for the deposit and dissemination of scientific research documents, whether they are published or not. The documents may come from teaching and research institutions in France or abroad, or from public or private research centers.

L'archive ouverte pluridisciplinaire **HAL**, est destinée au dépôt et à la diffusion de documents scientifiques de niveau recherche, publiés ou non, émanant des établissements d'enseignement et de recherche français ou étrangers, des laboratoires publics ou privés.

DOUBLE AND SINGLE LAYERS FLUX-SWITCHING PERMANENT MAGNET MOTORS: FAULT TOLERANT MODEL FOR CRITICAL APPLICATIONS

Guangjin Li, Javier Ojeda, Emmanuel Hoang, Mohamed Gabsi
SATIE, ENS CACHAN, CNRS, UNIVERSUD, 61, av President Wilson F-94230-Cachan, France.
E-mail: guangjin.li@satie.ens-cachan.fr

Abstract—This paper deals a double layer and a single layer Flux-Switching Permanent Magnet (FSPM) motors for a fault tolerant application. The self and mutual inductances of these two machines are calculated, which are then applied for establishing a faulty model. A three phase short-circuit problem is simulated for these two motors. A comparison between these two machines is carried out, which is in terms of normal phase currents and the output torque before and after the failure as well as the short-circuit peak currents against the rotor velocity.

I. INTRODUCTION

THANKS to their high torque density and their simple rotor structure, which is similar to that of the Switched Reluctance Motors (SRMs), the Flux-Switching Permanent Magnet (FSPM) motors attract more and more attentions in the critical application as the Hybrid Vehicles and aerospace [1][2], in which the reliability of system is essential. In order to enhance the fault tolerant capability of electrical machines, the redundant structure can be applied [3] [4] [5]. As shown in the Fig. 1 (I), both the machines have one primary star and one redundant star, which are excited independently as shown in the Fig. 4. In the double layer FSPM motor, there are two layers of adjacent phases in the same stator slot. The primary star constituted by the phases $A1$, $B1$ and $C1$ and the redundant star constituted by the phases $A2$, $B2$ and $C2$. This is the same for the single layer FSPM motor, while the only difference is that there is only one layer of the same phase in each stator slot. Under normal mode, only the primary star is excited for the double layer FSPM motor as well as for the single layer FSPM motor.

Under faulty mode, open-circuit or short-circuit, the primary star should be opened and the redundant star is excited so as to guaranty the drive continuity of the FSPM motors. Generally, the open-circuit failure is not as serious as the short-circuit ones, because it is sufficient to open all the primary star and use the redundant one, there will be no influence of the open-circuit phases on the other normal phases. Thus, the open-circuit problems will not be studied in this paper. While under short-circuit failure, even the switch of the short-circuit phase is opened, the short-circuit current still exists and will disturb the normal phases because of the magnetic coupling between phases.

In order to compare the fault tolerant capability of these two machines, the self and mutual inductances are firstly calculated in this paper, and a faulty model is then carried out to analyse the variations of the normal currents and the output torque before and after the short-circuit fault.

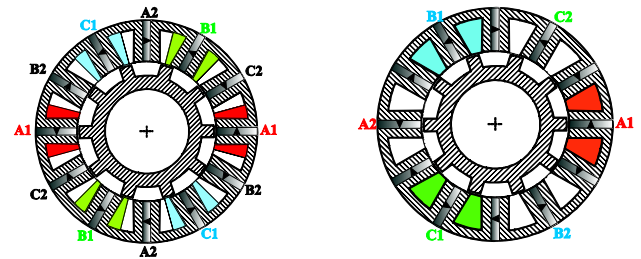

(a) double layer FSPM motor

(b) single layer FSPM motor

(I) machine cross section

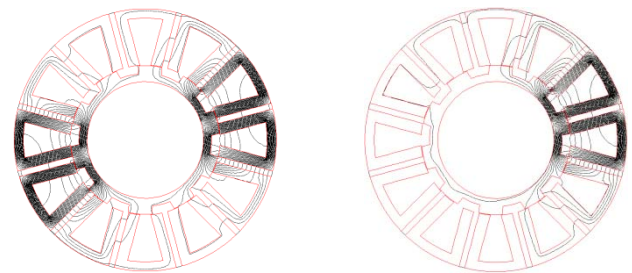

(a) double layer FSPM motor

(b) single layer FSPM motor

(II) flux distribution

Fig. 1 Cross section of the Dual-Star FSPM motors and their flux distribution with one phase excited with constant current.

II. ELECTROMAGNETIC CHARACTERISTICS OF DIFFERENT FSPM MOTORS

Since the two FSPM motors have the similar stator as well as rotor and, the only difference is the winding geometry, the flux path of one phase excited of these two FSPM motors can then be established by using one common cross section shown in the Fig. 2 (a). Based on the flux path, the equivalent lumped magnetic circuit can be obtained as shown in the Fig. 2 (b). It should be noted that for the double layer FSPM motor, the two stator teeth of the same phase are symmetrical (see the Fig. 1 (II) (a)) and the turn number of the equivalent lumped magnetic circuit should be one half of the total phase. Furthermore, the obtained inductance by the Fig. 2 (b) should be multiplied by two times to obtain the phase inductances of the double layer FSPM motor.

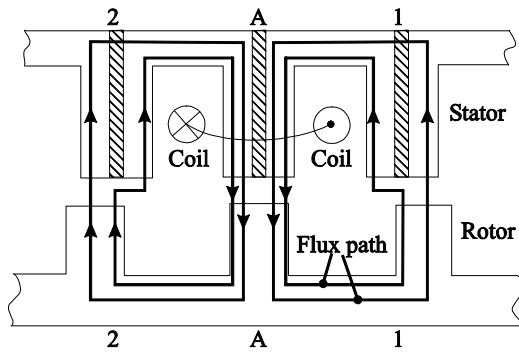

(a) phase flux distribution

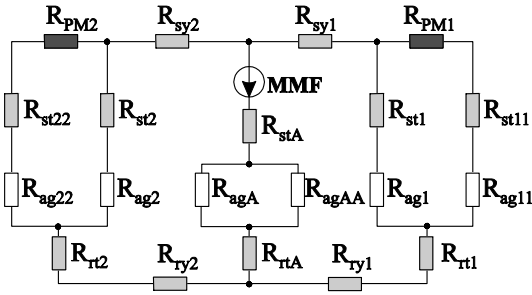

(b) simplified equivalent lumped magnetic circuit

Fig. 2 Path of flux with one phase excited and their equivalent lumped magnetic circuit of FSPM motors.

The general expression describing the magnetic reluctance in the Fig. 2 (b) could be established as:

$$R_i = \frac{1}{\mu_r \mu_0} \frac{l}{s} \quad (1)$$

where μ_r and μ_0 are respectively the relative permeability and the permeability of free space, l and s are respectively the length and the area of the cross section of the flux path. For simplicity, the part 1 and the part 2 in the Fig. 2 (b) are considered as identical. Thus, the equivalent reluctance in the Fig. 2 (b) could be finally established as in (2).

$$R_{eq} = \left\{ R_{stA} + \frac{R_{agA} \cdot R_{agAA}}{R_{agA} + R_{agAA}} + R_{rtA} + \frac{1}{2} [R_{ry1} + R_{rt1} + \frac{(R_{st1} + R_{ag1})(R_{st11} + R_{ag11} + R_{PM1})}{R_{st1} + R_{ag1} + R_{st11} + R_{ag11} + R_{PM1}} + R_{sy1}] \right\} \quad (2)$$

where

- Stator teeth reluctance : R_{stA} , R_{st1} and R_{st11} ,
- Stator yoke reluctance : R_{sy1} ,
- Air-gap reluctance : R_{agA} , R_{agAA} , R_{ag1} and R_{ag11} ,
- Rotor teeth reluctance : R_{rtA} et R_{rt1} ,
- Rotor yoke reluctance : R_{ry1} ,
- Permanent magnet : R_{PM1} .

The relationship between the reluctance (R), the inductance (L) and the phase turn number (N) (for the two machines, the

phase turn numbers are the same) could be established as (3) and the expression of the phase inductance of these two FSPM motors could be finally obtained as follows:

$$L = \frac{N^2}{R} \quad (3)$$

$$\begin{cases} L_{double} = 2 \frac{(N/2)^2}{R_{eq}} = \frac{(N)^2}{2R_{eq}} \\ L_{single} = \frac{N^2}{R_{eq}} \end{cases} \quad (4)$$

where L_{double} and L_{single} are respectively the phase self inductances of the double layer and the single layer FSPM motors. It is found that the self inductance of the double layer machine (L_{double}) is practically twice as low as that of the machine with simple layer (L_{single}). On the contrary, for the mutual inductance between phases of both FSPM motors, it can be noted that FSPM motor with single layer has lower mutual inductances than those of FSPM motor with double layer because as in Fig. 1, there are obviously more mutual fluxes between phases in FSPM motor with double layer than those in FSPM motor with single layer [6] [7] [8].

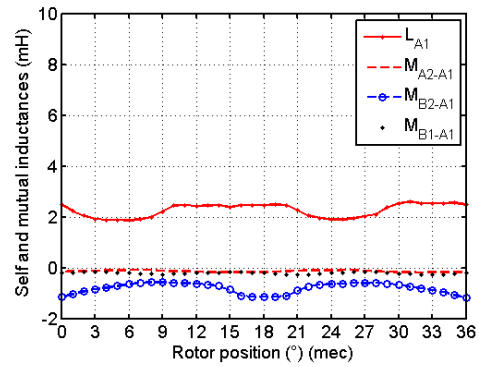

(a) double layer FSPM motor

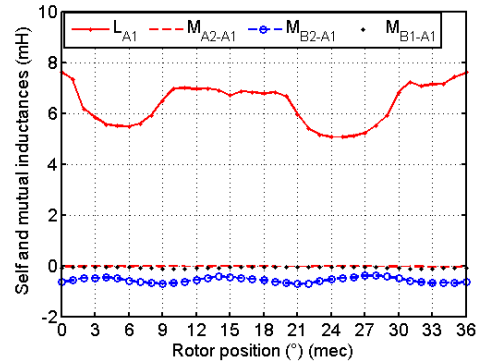

(b) single layer FSPM motor

Fig. 3 Self and mutual inductances against rotor positions for different FSPM motors.

The self and mutual inductances are also calculated by Finite Element Method (FEM) 2D, the results of self and mutual inductances against rotor positions are illustrated in Fig. 3. Only self and mutual inductances of the phase $A1$ are chosen, the other phases (phase B and phase C) are similar to the phase A while with a phase separation of one-third electrical cycle. It is found that the self inductance of the single layer FSPM motor is approximately 3 times higher than that of the double layer FSPM motor instead of 2 times as predicted analytically. This could be due to the magnetic saturation and the flux leakage. The mutual inductances between phases of the single layer FSPM motor are practically one half of those of the double layer FSPM motor. The higher self inductances and the lower mutual inductances lead to a higher fault tolerant capability. Generally, under the same short-circuit failure conditions, e.g. the same rotor velocity, the same phase currents, an higher self inductance leads to a lower short-circuit current. Furthermore, the lower mutual inductances lead to lower magnetic coupling between phases and prevent the failure from infecting the other normal phases. As result, the reliability of the system could be reinforced. In order to verify these assumptions, a faulty model is carried out in the following parts.

III. FAULTY MODELS OF THE TWO FSPM MOTORS

As mentioned previously, the fault tolerance capabilities of these two FSPM motors could be different, in order to compare the fault tolerance capabilities, the failure problem will be studied. For simplicity, the failure as three primary phases short-circuited is considered, at the same time, the three redundant phases are excited to guaranty the drive continuity of the machines. The equivalent circuit of three primary phases short-circuited is shown as follows:

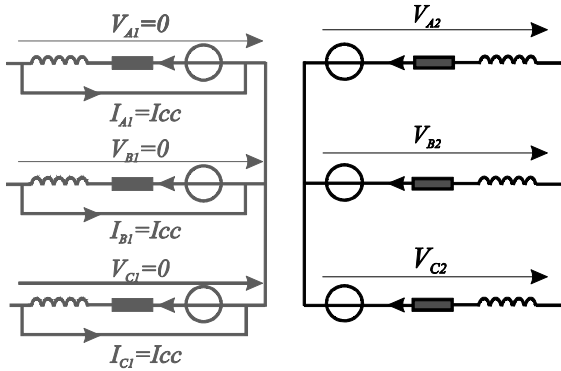

Fig. 4 Equivalent circuit of the three primary phase short-circuited of the double layer as well as single layer FSPM motors.

As shown in the Fig. 4, the two neutral points of the primary star and the redundant star are isolated and inaccessible, thus, the relationship between the three primary and the three redundant phase currents could be established as follows:

$$i_{A1} + i_{B1} + i_{C1} = 0 \text{ and } i_{A2} + i_{B2} + i_{C2} = 0 \quad (5)$$

The general expression of the phase output voltage (v) of the two stars is:

$$v = Ri + L \frac{di}{dt} + e_0 \quad (6)$$

where i , R , L and e_0 are the phase current, the phase resistance, the phase inductance (self and mutual) and the phase no-load electromotive force (EMF), respectively. With the flux linkage (Φ_f) due to permanent magnets obtained by FEM 2D, the EMF can be also obtained as follows:

$$e_0 = \frac{d\Phi_f}{dt} = p\Omega \frac{d\Phi_f}{d\theta_e} \quad (7)$$

where p , Ω and θ_e are respectively the pole pair number, the rotor mechanical velocity and the electrical angle of rotor. Under sinusoidal permanent regime, the (6) can be rewritten under matrix formes as follows:

$$[v] = [R][i] + p\Omega[L][i] + p\Omega[\Phi_f] \quad (8)$$

where the matrix terms are given as:

$$[R] = \begin{bmatrix} R_0 & 0 & 0 & 0 & 0 & 0 \\ 0 & R_0 & 0 & 0 & 0 & 0 \\ 0 & 0 & R_0 & 0 & 0 & 0 \\ 0 & 0 & 0 & R_0 & 0 & 0 \\ 0 & 0 & 0 & 0 & R_0 & 0 \\ 0 & 0 & 0 & 0 & 0 & R_0 \end{bmatrix} \quad (9)$$

$$[L] = \begin{bmatrix} L_0 & M_0 & M_0 & M_1 & M_2 & M_2 \\ M_0 & L_0 & M_0 & M_2 & M_1 & M_2 \\ M_0 & M_0 & L_0 & M_2 & M_2 & M_1 \\ M_1 & M_2 & M_2 & L_0 & M_0 & M_0 \\ M_2 & M_1 & M_2 & M_0 & L_0 & M_0 \\ M_2 & M_2 & M_1 & M_0 & M_0 & L_0 \end{bmatrix} \quad (10)$$

$$[\Phi_a] = \begin{bmatrix} \Phi_{aA1} \\ \Phi_{aB1} \\ \Phi_{aC1} \\ \Phi_{aA2} \\ \Phi_{aB2} \\ \Phi_{aC2} \end{bmatrix} = \hat{\Phi}_a \begin{bmatrix} \cos(p\theta) \\ \cos(p\theta - 2\pi/3) \\ \cos(p\theta + 2\pi/3) \\ \cos(p\theta) \\ \cos(p\theta - 2\pi/3) \\ \cos(p\theta + 2\pi/3) \end{bmatrix} \quad (11)$$

$$[i] = I_{max} \begin{bmatrix} \cos(p\theta + \pi/2 - \psi) \\ \cos(p\theta + 2\pi/3 + \pi/2 - \psi) \\ \cos(p\theta - 2\pi/3 + \pi/2 - \psi) \\ \cos(p\theta + \pi/2 - \psi) \\ \cos(p\theta + 2\pi/3 + \pi/2 - \psi) \\ \cos(p\theta - 2\pi/3 + \pi/2 - \psi) \end{bmatrix} \quad (12)$$

where M_0 are the mutual inductances between the phases of the same star as the phase $A1$ and the phase $B1$, M_1 are the mutual inductances between the correspondent phases of different stars as the phase $A1$ and the phase $A2$, M_2 are the mutual inductances non-correspondent of two stars as the phase $A1$ and the phase $B2$. For the short-circuit phase, the output phase voltage in the (8) is null. In order to simplify the control strategy, we consider that the primary star is always

excited, and at certain times, we short-circuit artificially the three redundant phases. As an example, the phase $A2$ is chosen for calculating the short-circuit current. With the generator convention, the expression of the no-load EMF of the phase $A2$ could be established as in (13).

$$e_{A2} = p\Omega \frac{d\Phi_{A2}}{d\theta_e} = \left\{ R_{A2}i_{A2} + L_{A2} \frac{di_{A2}}{dt} + M_0 \frac{di_{B2}}{dt} + M_0 \frac{di_{C2}}{dt} + M_1 \frac{di_{A1}}{dt} + M_2 \frac{di_{B1}}{dt} + M_2 \frac{di_{C1}}{dt} \right\} \quad (13)$$

Knowing that the sum of three currents of the same star is null, the (13) can be simplified to:

$$e_{A2} = R_{A2}i_{A2} + L_{cs} \frac{di_{A2}}{dt} + M \frac{di_{A1}}{dt} \quad (14)$$

with $L_{cs} = L_{A2} - M_0$ (cyclic inductance) and $M = M_1 - M_2$. Supposing that $e_{A2} = e_{A1}$ (verified by FEM 2D) and without flux weakening operation, the expression of short-circuit current can be established as in (15).

$$i_{A2}(t) = \left\{ \frac{MI_{A1}}{L_{cs}(\omega^2 + (1/\tau)^2)} \left[\omega \left(\frac{1}{\tau} + \frac{E_{A1}}{MI_{A1}} \right) \cos(\omega t) + \left(\omega^2 - \frac{E_{A1}}{MI_{A1}\tau} \right) \sin(\omega t) \right] - \frac{MI_{A1}\omega}{L_{cs}(\omega^2 + (1/\tau)^2)} \left(\frac{1}{\tau} + \frac{E_{A1}}{MI_{A1}} \right) e^{-\frac{t}{\tau}} \right\} \quad (15)$$

With $e_{A1}(t) = E_{A1} \cos(\omega t + \pi/2)$, $i_{A1}(t) = I_{A1} \cos(\omega t + \pi/2)$, $\tau = L_{cs}/R_a$ (electrical time constant) and ω (rotor electrical velocity). When the machines enter in the permanent regime, the expression of short-circuit current could also be deduced as follows:

$$i_{A2}(t) = K\sqrt{A^2 + B^2} \cos(\omega t + \varphi) \quad (16)$$

with $K = \frac{MI_{A1}}{L_{cs}(\omega^2 + (1/\tau)^2)}$, $A = \omega \left(\frac{1}{\tau} + \frac{E_{A1}}{MI_{A1}} \right)$, $B = \left(\omega^2 - \frac{E_{A1}}{MI_{A1}\tau} \right)$ and $\varphi = \arctan(B/A)$. Since the three redundant phases are symmetrical, thus, the amplitudes of the three short-circuit currents are identical while with a phase separation of one third of electrical period ($2\pi/3$). Since the phase resistances and the mutual inductances between phases are not negligible, there will be a resistant torque produced by the short-circuit currents. In order to analyse the influence of the short-circuit currents on the normal currents, the rotor velocity and the total torque of the machines, some simulations based on Simulink-MATLAB are realised, and the control block diagram is shown in the Fig. 5. The current is controlled by a hysteresis controller while the velocity is controlled by a PI controller.

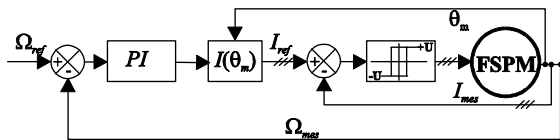
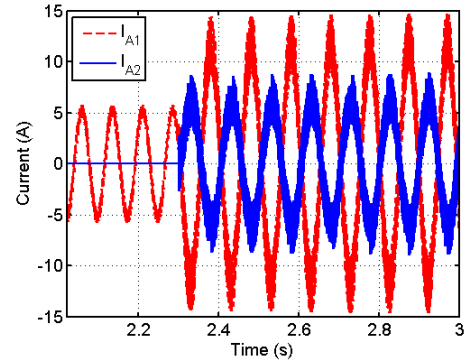

Fig. 5 Control block diagram of the two FSPM motors under normal and faulty models.

The experimental tests are also realized, the parameters of the motor and the stator as well as the rotor are given in appendix.

In the simulation, a resistant torque of 4 Nm and a rotor velocity of 10 rad/s are imposed. The measurement is only realised for the double layer FSPM motors. The results of the normal and the short-circuit current, the total torque before and after the short-circuit of three phases are shown in the Fig. 6, SC means short-circuit in all the figures. It is found that under faulty mode, both the normal and the short-circuit currents of the double layer FSPM motor are higher than those of single layer FSPM motor. This leads that the double layer FSPM motor has a much higher copper losses under faulty mode. Furthermore, the drop of total torque of the double layer FSPM motor is considerably stronger than that of the single layer FSPM motor, this is due to the higher short-circuit currents of the double layer FSPM motor, which leads to higher resistant torque.



(a) Normal and short-circuit current of double layer FSPM

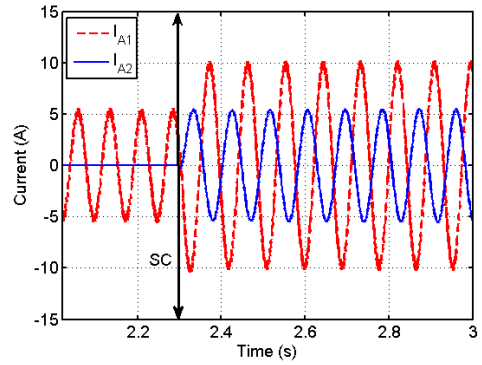

(b) Normal and short-circuit current of single layer FSPM

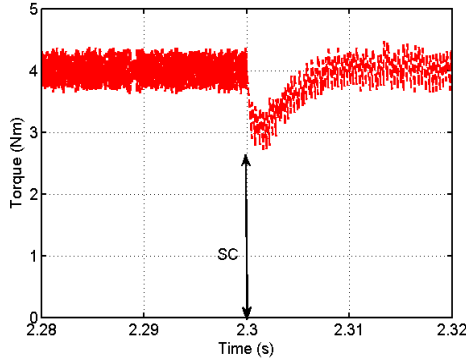

(c) Torque of double layer FSPM

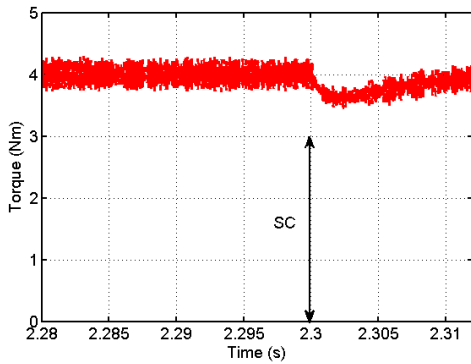

(d) Torque of single layer FSPM

Fig. 6 Comparison between the double and single layer FSPM motors in terms of normal and short-circuit currents and) total torque.

In order to predict the maximum short-circuit current, the short-circuit current against the rotor velocity is calculated analytically and then verified by simulations as well as by experiments. The results are shown in the Fig. 7. It is found that at high rotor velocity, the short-circuit peak currents trend to be constant, because at high rotor velocity, the influence of resistance and the mutual inductances can be neglected, and the short-circuit current can be obtained by the no-load phase flux linkage divided via the phase self inductance, which leads to a short-circuit current independent on the rotor velocity. Furthermore, because the self inductance of the double layer FSPM motor is approximately two times higher than that of the single layer FSPM motor, the short-circuit current of the single layer could be two times lower than that of the double layer FSPM motor. This lower short-circuit current is essential for critical applications, because to compensate the resistant torque due to the short-circuit currents, lower normal currents are needed. This leads to lower copper losses and also lower disturbance of the system.

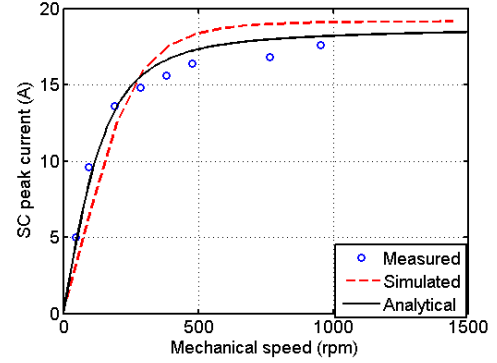

(a) double layer

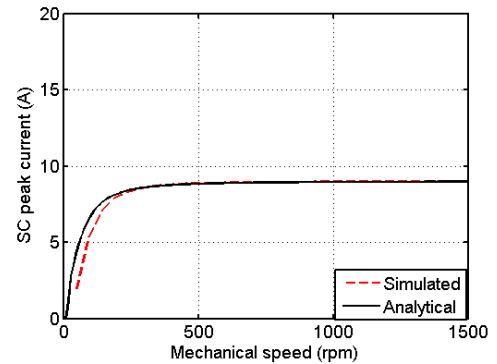

(b) single layer

Fig. 7 The short-circuit current against mechanical velocity of the two FSPM motors when the three primary phases are short-circuited.

IV. CONCLUSION

In this paper, between a double layer FSPM motor and a single layer FSPM motor the comparison in terms of self and mutual inductances as well as the maximum short-circuit current against the rotor velocity is carried out. The results have shown that the single layer FSPM motor has higher fault tolerance capability, because it has higher self inductances while with lower mutual inductances. Thus, under faulty mode as short-circuit, for example, the higher self inductances limit the increase of short-circuit currents and the lower mutual inductances, which means lower magnetic coupling, prevent the faults from infecting the normal phases. It should also be noted that the increase of self inductances will decrease the power factor, while for the critical applications, this is not the main topic and has not been studied in this paper.

For the single layer FSPM motor, it should be noted that, due to the non-symmetric structure, there will be a strong normal force. This would lead to a high vibration level. Thus, in practical applications, it is proposed to use the FSPM motor with 24 stator teeth and 20 rotor poles. Like this, for each phase, we can have two opposite teeth. As a result, the sum of normal force versus rotor position could be decreased considerably, and the vibration could be limited to a low level.

V. APPENDIX



(a) Stator

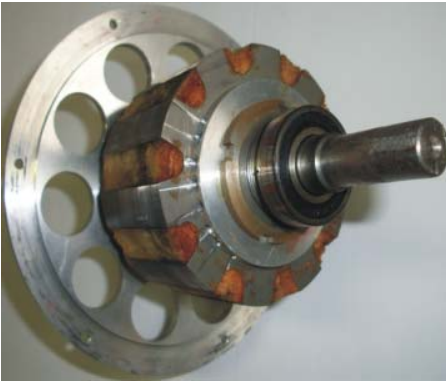

(b) Rotor

Fig. 8 Prototype of double layer FSPM motor 12/10.

STRUCTURAL DATA OF FSPM MOTOR 12/10 (PROTOTYPE)

Number of stator/rotor poles (N_s/N_r)	12/10
Stator outer radius (r_s outer)	77.2 mm
Rotor outer radius (r_r outer)	43 mm
Stack length (L_a)	60 mm
Air-gap length (e)	0.2 mm
Number of phase coils (N)	50
Filling factor (k_b)	0.4
Remanent flux density (Br) (200°C)	0.8 T
Self inductance (L_θ)	2.6 mH
Mutual inductance (M_θ)	1.02 mH
No-load phase flux (Φ_0)	51 mWb
Moment of inertia (J)	$1.8 \times 10^{-3} \text{ kg}\cdot\text{m}^2$
Coefficient of friction (f)	$20 \times 10^{-6} \text{ Nm}\cdot\text{s}$

VI. REFERENCES

- permanent magnet polyphased synchronous machines," in *in Proc. 7th Eur. Conf. Power Electron. Appl.*, 1997, p. 903–908.
- [2] Z. Q. Zhu et al., "Analysis of electromagnetic performance of flux-switching permanent magnet machines by non-linear adaptive lumped parameter magnetic circuit model," *IEEE Trans. Magn.*, vol. 41, no. 11, p. 4277–4287, Nov. 2005.
- [3] M.-A. Shamsi-Nejad, B. Nahid-Mobarakeh, and S. Pierfederici, "Fault tolerant and minimum loss control of double- star synchronous," *IEEE Trans. Ind. Electron.*, vol. 55, no. 5, p. 1956–1965, may 2008.
- [4] N. Takorabet et al., "Study of Different Architectures of Fault Tolerant Actuator Using a Double-Star PM Motor," in *IEEE Industry Applications Society Annual Meeting, 2008. IAS'08*, 2008.
- [5] N. Ertugrul, W. Soong, G. Dostal, and D. Saxon, "Fault tolerant motor drive system with redundancy for critical applications," in *Power Electronics Specialists Conference, IEEE 33rd Annual*, 2002, pp. 1457–1462.
- [6] N. Bianchi, S. Bolognani, M.D. Pre, and G. Grezzani, "Design considerations for fractional-slot winding configurations of synchronous machines," *IEEE Trans. Ind. Appl.*, vol. 42, no. 4, pp. 997–1006, July-Aug. 2006.
- [7] A.S. Thomas, Z.Q. Zhu, R.L. Owen, G.W. Jewell, and D. Howe, "Multiphase Flux-Switching Permanent-Magnet Brushless Machine for Aerospace Application," *IEEE Trans. Ind. Appl.*, vol. 45, no. 6, pp. 1971–1981, Nov./dec. 2009.
- [8] R.L. Owen, Z.Q. Zhu, A.S. Thomas, G.W. Jewell, and D. Howe, "Fault-Tolerant Flux-Switching Permanent Magnet Brushless AC Machines," in *Industry Applications Society Annual Meeting, 2008. IAS '08. IEEE*, 5-9 Oct. 2008, pp. 1-8.
- [1] E. Hoang, A. H. Ben-Ahmed, and J. Lucidarme, "Switching flux