



**HAL**  
open science

# Method of Evaluating the Zero-Sequence Inductance Ratio for Electrical Machines

Luis de Sousa, Hussein Dogan

► **To cite this version:**

Luis de Sousa, Hussein Dogan. Method of Evaluating the Zero-Sequence Inductance Ratio for Electrical Machines. EPE 2011, Aug 2011, Birmingham, United Kingdom. pp.ISBN: 9789075815153. hal-00623625

**HAL Id: hal-00623625**

**<https://hal.science/hal-00623625>**

Submitted on 14 Sep 2011

**HAL** is a multi-disciplinary open access archive for the deposit and dissemination of scientific research documents, whether they are published or not. The documents may come from teaching and research institutions in France or abroad, or from public or private research centers.

L'archive ouverte pluridisciplinaire **HAL**, est destinée au dépôt et à la diffusion de documents scientifiques de niveau recherche, publiés ou non, émanant des établissements d'enseignement et de recherche français ou étrangers, des laboratoires publics ou privés.

# Method of Evaluating the Zero-Sequence Inductance Ratio for Electrical Machines

Luis De Sousa, IEEE member  
Valeo Powertrain Systems  
14 av. des Béguines -95600 Cergy  
[luis.de-sousa@valeo.com](mailto:luis.de-sousa@valeo.com)

Hussein Dogan, IEEE Student member  
Grenoble Electrical Engineering Laboratory  
(G2Elab) ENSE (Grenoble INP-UJF, CNRS UMR5529)  
BP46 – 38402 Saint Martin d'Hères Cedex, France  
[Hussein.Dogan@g2elab.grenoble-inp.fr](mailto:Hussein.Dogan@g2elab.grenoble-inp.fr)

## Acknowledgement

The SOFRACI project, high efficiency inverter with integrated charge function, is certified by the French automotive cluster, MOV'EO. Special thanks to G2ELAB and Leroy Somer for their technical support concerning the electrical machine design.

## Keywords

Zero-sequence machine, mutual inductance, permanent magnet synchronous machine, multiphase machine, 3H-Bridge Inverter, open winding machine

## Abstract

A Three-Phase machine with independent phases could be an efficient solution. The main drawback of such configuration is the control of the zero-sequence (ZS) currents. The ZS inductance is not a usual criterion for the electrical machine selection. This paper describes the zero-sequence inductance issue and proposes a method to quickly evaluate the intrinsic ZS inductance.

## Introduction

Currently, the automotive industry is investing heavily on the electrification of vehicles. The overall efficiency could be improved by means of new topologies [1]. A Three-Phase machine with independent phases [2] could be an efficient solution to increase the effective voltage and reduce the current and then to increase the efficiency. In addition, this new electric drive is reconfigurable as a Single-Phase or Three-Phase battery charger [3],[4],[5]. This feature is very interesting for EVs which need a fast charging solution and cost reduction. The fast charging option is implemented without any additional components except the EMI filters and also without any drivability performances downgrading. In the contrary, the performances of the system are also enhanced [2]. Other topologies have been proposed [6], [7], [8], [9], [10], [11], [12]. Most of the solutions mentioned above, except [9] and [10], reusing the motor and the inverter as battery charger, cannot offer a three-phase solution with any type of electric motor.

Nevertheless, this solution is based on three independent phases. There is no neutral point. The sum of the three-phase currents could be non null in traction mode. This current is called Zero-Sequence current. The main drawback of such configuration is the control of the ZS currents. The ZS inductance is not a usual criterion for the electrical machine selection. This is reason why this paper proposes a method to quickly evaluate the intrinsic ZS inductance. The method is based on the air gap energy calculation. A ratio between the ZS inductance and the self inductance is easily calculated. By this way, a new criterion is built: the ZS inductance ratio.

## 1. Topology of the combined electric drive and fast battery charger

The topology is based on a 3H-Bridge inverter and a three-phase machine with electrically independent phases. From a magnetic point of view, some couplings between phases are possible: this

is the purpose of the paper which deals with ZS inductance. The Fig.1 shows such machine in a split-phase configuration. The split-phase machine allows to the electric drive to be reconfigured in fast battery charger. The grid currents flow in the midpoints of the coils and go through the winding in opposite direction. By this way, no rotating field is generated in the air gap and the motor shaft cannot move during the battery charge. In traction mode, the grid is not connected to the EM. The midpoints are floating but the main difference with a classical three-phase electric drive is that the neutral point is missing. The neutral point connection is a kind of electric coupling that cancels the zero-sequence currents. This is the reason why a ZS inductance is required firstly to make the EM controllable and secondly to limit ZS currents harmonics.

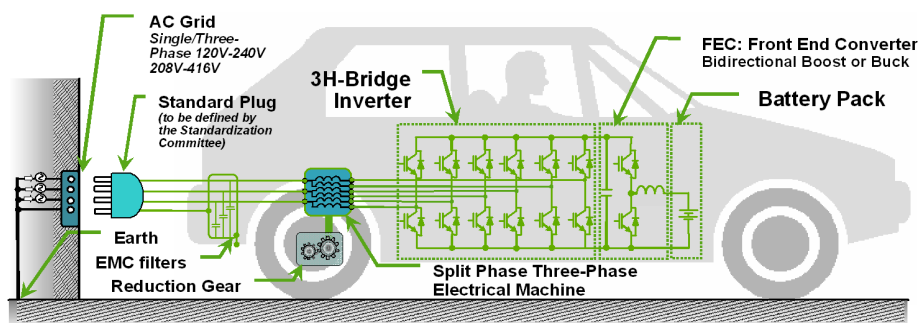

a)

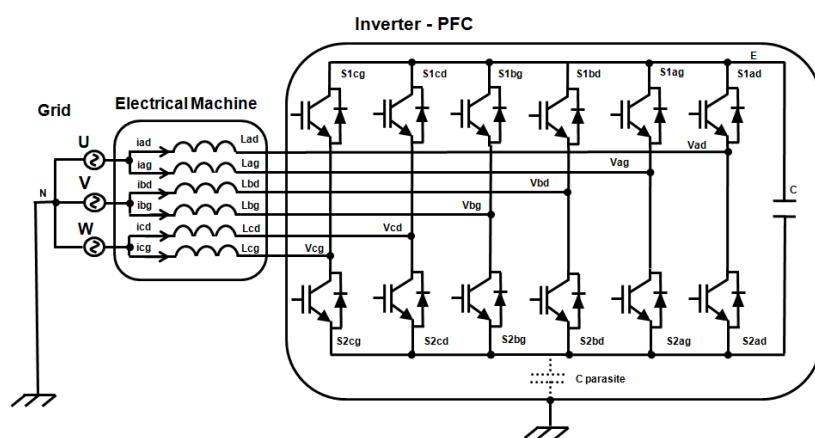

b)

Fig. 1: Combined Electric Drive and Fast Battery Charger: a) overview b) in Battery Charger Mode

As shown in fig.2a, the proposed topology cannot cancel the ZS current. The sum of current flowing through each phase may be not null. In contrary, Fig.2b shows the standard Three-Phase inverter with a wye connection. The floating Neutral point prevents the zero-sequence current to flow. The open winding configuration, we cannot guarantee that the ZS current is null. We define  $i_o$  the ZS current:

$$i_A + i_B + i_C = i_o \neq 0 \tag{1}$$

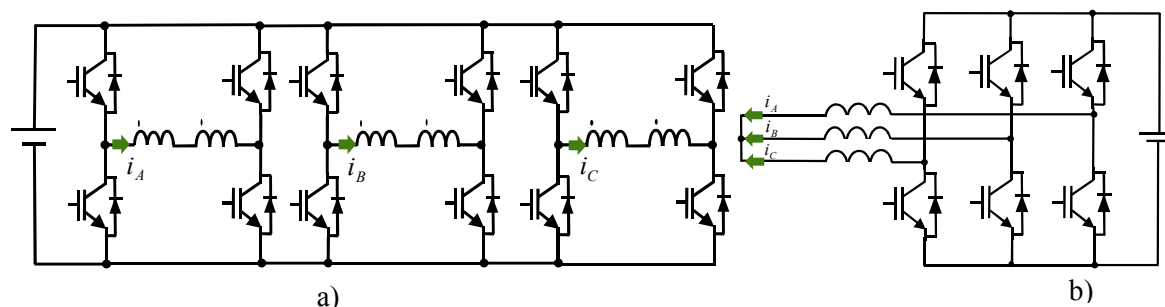

Fig. 2: Three-Phase Electric Drive: a) open winding configuration b) wye configuration

ZS currents take place because of ZS voltage. DC, Low and high frequency zero-sequence voltages may be generated by the inverter (PWM, unbalanced delays...) or the machine itself (Third harmonics on the back-EMF). It is impossible to ensure a perfect zero offset on the command.

$$v_A + v_B + v_C = v_O \neq 0 \quad (2)$$

## 2. The Zero-Sequence Inductance in Electrical Machine

### 2.1. Definition

The zero-sequence inductance is flux to current ratio if a winding is excited by a zero-sequence current. Zero-sequence currents are homopolar currents. The standard [13] defines the measurement method.

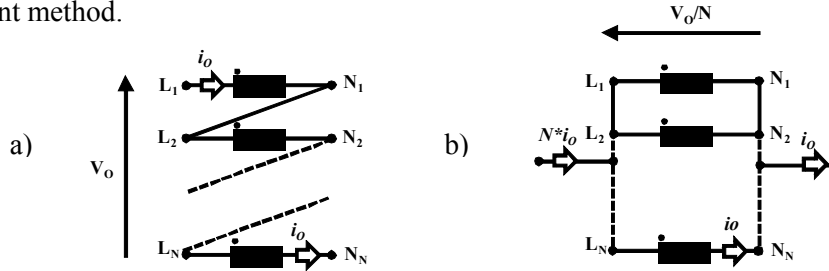

Fig. 3: Zero-sequence inductance measurement: a) series b) parallel

The fig.3 shows two equivalent methods to measure the ZS inductance. The phases are wired either in series or parallel. Usually, it is more practical in parallel because all the phases are already linked to a neutral point. The ZS inductance is defined as:

$$Z_O = \frac{V_O}{N * i_O} \quad (3)$$

In case of a multiphase machine, we define an inductance matrix in Eq.4 which links all the voltages and the currents of the EM. The diagonal elements of the matrix represent the self inductance of each phase. The other elements represent the mutual inductances that bind each phase with each other. These inductances may depend on the rotor position.

$$\begin{bmatrix} \phi_1 \\ \phi_2 \\ \dots \\ \phi_N \end{bmatrix} = \begin{bmatrix} L_1(\theta) & M_{1,2}(\theta) & \dots & M_{1,N}(\theta) \\ M_{2,1}(\theta) & L_2(\theta) & \dots & M_{2,N}(\theta) \\ \dots & \dots & \dots & \dots \\ M_{N,1}(\theta) & M_{N,2}(\theta) & \dots & L_N(\theta) \end{bmatrix} * \begin{bmatrix} i_1 \\ i_2 \\ \dots \\ i_N \end{bmatrix} \quad (4)$$

By applying the measurement method seen previously, we calculate the ZS inductance. We assume that the current is equal in each phase. Then, the summation of all the lines gives the ZS flux or the ZS voltage.

$$L_O = \frac{1}{N} \left( \sum_{k=1}^N L_k(\theta) + \sum_{j,k=1}^N M_{j,k}(\theta) \right) \quad (5)$$

In the particular case of a balanced three-phase EM having no saliency, we guess from Eq.4:

$$L_O = L + 2M \quad (6)$$

where  $L$  is the self inductance and  $M$  the mutual inductance. It is interesting to normalize the ZS inductance in order to compare every machine regardless the design in terms of size, of number of turns, of air gap or anything that might affect the self inductance. We define the ZS inductance ratio as the ZS inductance to self inductance ratio.

$$\text{Zero-Sequence InductanceRatio} = \frac{L_O}{L} \quad (7)$$

This paper shows that this ratio is easily calculated with no assumptions on the design of the machine.

## 2.2. Singularities and non-singularities

It is interesting to study the singularity of the matrix. If the matrix is non invertible, it means that the current are not defined, mathematically speaking, when the voltage across each phase is forced. We consider an ideal machine in Eq.9 with no leakage and with no saliency. The determinant is calculated in Eq.10.

$$\begin{bmatrix} \phi_a \\ \phi_b \\ \phi_c \end{bmatrix} = \begin{bmatrix} L & M & M \\ M & L & M \\ M & M & L \end{bmatrix} * \begin{bmatrix} i_a \\ i_b \\ i_c \end{bmatrix} \quad (9)$$

$$\det \left( \begin{bmatrix} L & M & M \\ M & L & M \\ M & M & L \end{bmatrix} \right) = 0 \Rightarrow L^3 + 2M^3 - 3LM^2 = 0 \Rightarrow \underbrace{(L+2M)}_{L_0} * (L-M) = 0 \Rightarrow \begin{cases} L_0 = 0 \\ L = M \end{cases} \quad (10)$$

The first case related to a machine having a null ZS inductance ( $L_0=0$ ) is not driveable by a 3H-bridge inverter because the voltage of each phase is forced at every moment. The second case ( $L=M$ ) is not a three-phase machine but a single-phase transformer. One way to remove the singularities is to reduce the dimension of the problem. An additional equation could link either the voltages or the current. For example, a standard three-phase inverter controlling a wye connected machine not imposes the voltage across the phase but the phase-to-phase voltage. The neutral point is in fact a degree of freedom. Zero-sequence current cannot flow through the neutral because it is opened. The additional equation is therefore:

$$i_a + i_b + i_c = 0 \quad (11)$$

We demonstrate in Eq.12 that the system becomes invertible thanks to the wye connection if  $M \neq L$

$$\begin{bmatrix} \phi_a \\ \phi_b \\ \phi_c \end{bmatrix} = \begin{bmatrix} L & M & M \\ M & L & M \\ M & M & L \end{bmatrix} * \begin{bmatrix} i_a \\ i_b \\ i_c \end{bmatrix} = \begin{bmatrix} L & M & M \\ M & L & M \\ M & M & L \end{bmatrix} * \begin{bmatrix} i_a \\ i_b \\ i_c \end{bmatrix} - \underbrace{M * \begin{bmatrix} 1 & 1 & 1 \\ 1 & 1 & 1 \\ 1 & 1 & 1 \end{bmatrix} * \begin{bmatrix} i_a \\ i_b \\ i_c \end{bmatrix}}_{\text{Null Quantity}} = \begin{bmatrix} L-M & 0 & 0 \\ 0 & L-M & 0 \\ 0 & 0 & L-M \end{bmatrix} * \begin{bmatrix} i_a \\ i_b \\ i_c \end{bmatrix} \quad (12)$$

In conclusion, an electric machine having a ZS inductance ( $L_0$ ) equal to zero is not controllable with a conventional wye connection but it is not controllable with an open winding connection (3H-Bridge).

## 2.3. Leakage inductance

Even if a machine having a null ZS inductance exists from a mathematic point of view, from a physical point of view a machine has always a minimum of ZS inductance. The leakage inductance is a part of the ZS inductance but its nature is fully different from the intrinsic ZS inductance. The flux linked to the leakage inductance goes through the winding ends or through the slots normally reserved for the winding and not for the flux. This flux generates EMI noise, additional skin effect and proximity effect on the windings. We may qualify this ZS inductance by stray ZS inductance. This is a “bad” ZS inductance. According to Eq.5, we show in Eq.13 that the ZS inductance includes the leakage.

$$\begin{bmatrix} \phi_a \\ \phi_b \\ \phi_c \end{bmatrix} = \begin{bmatrix} L + L_{leak} & M & M \\ M & L + L_{leak} & M \\ M & M & L + L_{leak} \end{bmatrix} * \begin{bmatrix} i_a \\ i_b \\ i_c \end{bmatrix} \Rightarrow L_0 = L_{leak} \quad (13)$$

Therefore, the method described in this paper calculates the “pure” or theoretical ZS inductance. This means that the leakage inductance is not considered since the calculation assumes ideal conditions: no flux leakage, infinite permeability of the magnetic material and a uniform air gap.

## 2.4 Example of Electrical Machine having a zero-sequence inductance null and non null

It is known in the academic literature that an ideal machine with no saliency and a perfectly sinusoidal winding distribution has a coupling factor of  $\frac{1}{2}$ . The mutual inductance is half the self inductance. According to Eq.6, this ideal machine has a null ZS inductance ( $L_0=0$ ). But this machine does not exist because the winding is never purely sinusoidal at least because of the discretization effect. A machine has a finite number of slots and conductors. Even if the shapes of the teeth are studied, the winding cannot generate a pure sinusoidal Magneto-Motive Force (MMF) along the stator. The tooth operates like a Zero-Order-Hold (ZOH).

Of course, with a high number of slots and a sinusoidal distribution of the winding, the ZS inductance tends toward zero. What is amusing is that the machine with a null ZS inductance is a machine not having a sinusoidal distribution but rectangular. A conventional concentrated winding “A B C” has no ZS inductance. All the family of double layer concentrated winding like 3 slots-2 poles, 6 slots-4 poles or 12 slots-8 poles represented in Fig4.a) has no ZS inductance.

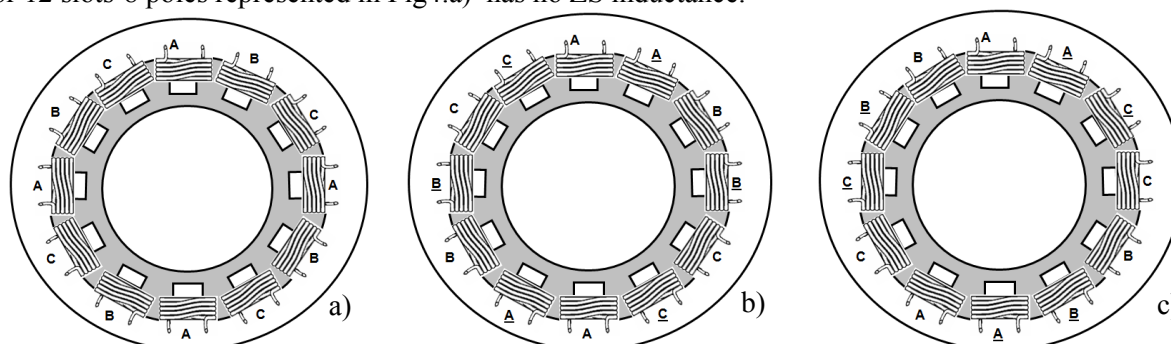

Fig. 4: Example of machines: a) Conventional 12-8 b) Zero mutual 12-8 c) Conventional 12-10

Moreover, with the same number of slot and pole, another winding can be built to produce a non null ZS inductance. The winding with the following elementary sequence “AABBCC” generate no mutual inductance between the phases like the Zero Mutual 12slots-8poles of Fig.4. This is explained by the fact that one coil is pushing the flux toward the rotor and another one of the same phase is sinking it. By this way, no flux is shared with the other two phases. Therefore, there is no mutual and then the ZS inductance ratio is 1.

$$\begin{bmatrix} \phi_a \\ \phi_b \\ \phi_c \end{bmatrix} = \begin{bmatrix} L & 0 & 0 \\ 0 & L & 0 \\ 0 & 0 & L \end{bmatrix} * \begin{bmatrix} i_a \\ i_b \\ i_c \end{bmatrix} \Rightarrow \frac{L_0}{L_s} = 1 \quad (14)$$

Another example of famous machine having its phases fully decoupled is the double layer concentrated winding 12 slots -10 poles family with the following elementary winding sequence: “AACCBBAACCBB”. This winding is more popular because its winding factor is much higher (93%). We have seen machine with a negative coupling, with no coupling but it is also possible to build a positive coupling (positive mutual). Assuming some symmetry, we guess that the maximum possible mutual factor is  $\frac{1}{2}$  for a three-phase machine. One phase cannot share more than half of its own flux with one of two others. Finally, the maximum ZS inductance ratio is 2 which is reached with the maximum positive coupling factor ( $+\frac{1}{2}$ ). The minimum one is 0 which is reached with the maximum negative coupling factor ( $-\frac{1}{2}$ ) and the neutral value 1 is reached for an uncoupled machine.

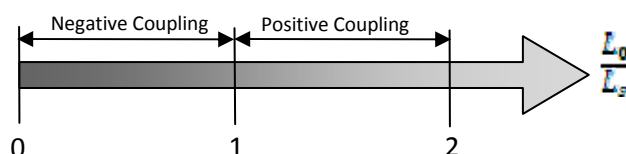

Fig. 5: Range of the Zero-Sequence Inductance Ratio

The following example has the maximum ZS inductance ratio. A four layer concentrated winding with 12 slots is shown in fig.6. This machine has no interest for industrial application because its winding factor is very small (33%). Nevertheless, from an academic point of view, it is interesting to study it because of its high positive coupling.

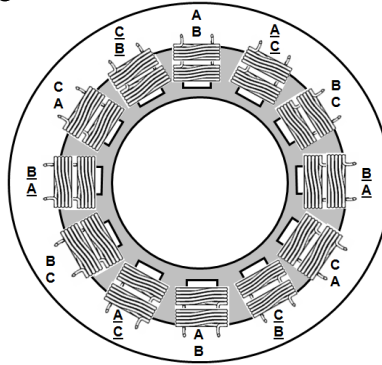

Fig. 6: Positive Mutual Machine

### 3. The Zero-Sequence Inductance Ratio calculation

#### 3.1. Hypothesis and method

For the calculation, we assumed that

- The machine has no magnetic leakage
- The reluctance of the magnetic material is considered null or negligible compared to the non magnetic material (air).
- The air gap is constant.
- The reluctance of the rotor is also null or negligible compared to the non magnetic material.

The method is based on the calculation of the air gap energy when only one phase is fed by a current. It is the “self” energy. The air gap energy when all the phases are crossed by the same current is also calculated. It is the zero-sequence energy.

$$\begin{cases} E_s = \frac{1}{2} L_s * I^2 \\ E_0 = \frac{3}{2} L_0 * I^2 \end{cases} \Rightarrow \frac{L_0}{L_s} = \frac{1}{3} \frac{E_0}{E_s} \quad (15)$$

The ratio of these two energies gives the ratio between the ZS inductance and the self inductance. The air gap energy is calculated by summing the energy of elementary volumes whose length is  $d\theta$ , height is the air gap  $e$ , and the depth is  $l$ .

$$E = \frac{e * l}{2\mu_0} \int_0^{2\pi} B^2 d\theta \quad (16)$$

We consider a discrete distribution of the winding and a finite number  $N$  of tooth. The width of the teeth is constant and equal to  $\theta_N = \frac{2\pi}{N}$ . The cross section of the tooth normal to the magnetic field is  $S = \theta_N * l$ .

$$E = \frac{e * l}{2\mu_0} \sum_{n=1}^N [B_n^2 * \theta_N] \Rightarrow E = \frac{e * l}{2\mu_0} \sum_{n=1}^N \left[ \frac{\phi_n^2}{S^2} * S \right] \Rightarrow E = \frac{e}{2\mu_0 S} \sum_{n=1}^N \frac{\phi_n^2}{l} \Rightarrow E = \frac{\mathfrak{R}}{2} \sum_{n=1}^N \phi_n^2 \quad (17)$$

$\mathfrak{R}$  is the reluctance of the air gap under one tooth. Now, we can express the ZS inductance ratio according to the ZS flux,  $\Phi_0$  and the self flux,  $\Phi_s$ :

$$\frac{L_0}{L_s} = \frac{1}{3} \frac{\sum_{n=1}^N \phi_0^2}{\sum_{n=1}^N \phi_s^2} \quad (18)$$

In order to calculate the energy, we need to calculate first the MMF, the air gap flux and then the air gap energy. These steps could be easily done by small calculations or graphically by counting the surface of the piecewise waveforms. With a similar approach, it is possible to calculate the mutual coefficient of the inductance matrix:

$$\frac{M_{i,j}}{L_s} = \frac{1}{3} \frac{\sum_{n=1}^N (\phi_i * \phi_j)}{\sum_{n=1}^N \phi_s^2} \quad (19)$$

### 3.2. Magneto-Motive force calculation

The calculation of the zero-sequence inductance needs the knowledge of the winding function of the stator. For each phase, we need to know the number of positive and negative turns on each slot. The absolute number of turns is useless. A normalization is enough and easier. The following example shows the winding of a 24 slots- 4 poles three-phase machine.

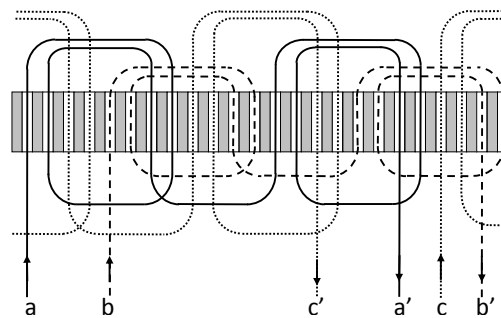

Fig. 7: 24slots-4poles winding arrangement

First, the MMF when only one phase (A for example) is supplied is plotted in Fig.8 a). The MMF is obtained by integrating the number of turns. The FMM is incremented or decremented following the sign and number of turns. It is assumed that  $i_a=1$ ,  $i_b=0$ ,  $i_c=0$ . The results called  $MMF(1,0,0)$  is represented in Fig.8 a). The same work is done when all the phase are supplied ( $i_a=1$ ,  $i_b=1$ ,  $i_c=1$ ). The results is the Zero-Sequence MMF,  $MMF(1,1,1)$ . The plot is shown in Fig.8b).

### 3.2 Air-gap flux and energy calculation

Since the air gap is assumed constant and the reluctance of the magnetic is considered infinitely high regarding the air, the relation between the MMF and the flux along the air gap is linear and linked only to reluctance of the air. It is worth to introduce this reluctance value because the final result is a ratio. Finally the air gap flux  $\Phi$  is deduced directly from the MMF plot. Nevertheless, the average is removed because the average flux along the stator shall be zero ( $\nabla \cdot \mathbf{B}=0$ ). This is the reason why the average of the MMF is subtracted to the plot so that the flux  $\Phi(1,0,0)$  and  $\Phi(1,1,1)$  are represented. As explained in §.3.1, the energy is calculated by integrating the square of the flux. The integration is easy: In Fig.8 the bricks are numbered for the “self” energy and for the zero-sequence energy.

$$\begin{cases} \sum \phi_s^2 = \sum \phi^2(1,0,0) = 20 \\ \sum \phi_o^2 = \sum \phi^2(1,1,1) = 12 \end{cases} \quad (20)$$

### 3.3 Zero-sequence inductance ratio examples

According to Eq.18, the ZS inductance ratio for the 24slots-4poles is one third of 12/20 i.e 20%.



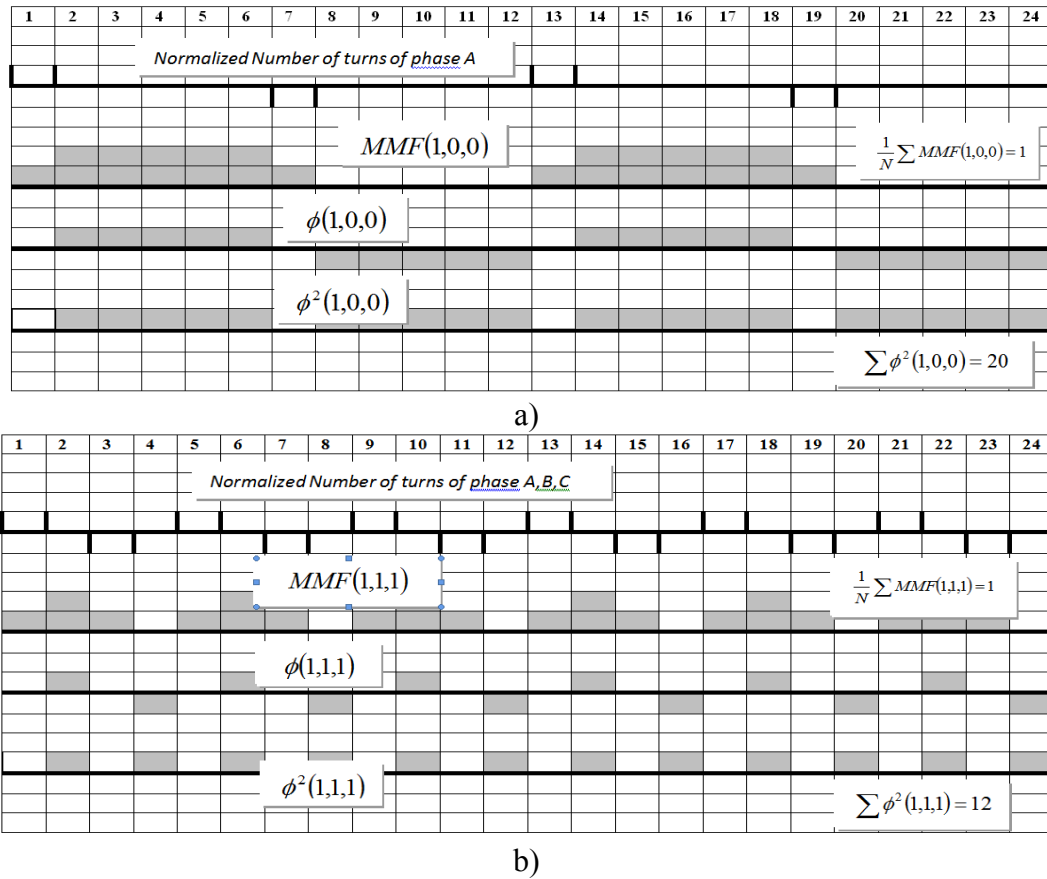

Fig. 8: Graphical Method: a) One phase is supplied b) all the phases are supplied

A computational program (M-file) is given in appendix for evaluate the inductance matrix and then the ZS inductance ratio just by entering the winding matrix. In §4, the results is checked by simulation. A new example of stator is given to be confronted with 2D Finite Element simulations. A 36slots –10 poles machine and 36slots – 8poles machine has respectively the winding matrix  $W_{36-10}$  and  $W_{36-8}$ .

$$W_{36-10} = \begin{bmatrix} 2 & 1 & 0 & -1 & -2 & 0 & 0 & 1 & 1 & 0 & 0 & 0 & -2 & 0 & 0 & 1 & 1 & 0 & 0 & -2 & 0 & -1 & 0 & 1 & 2 & 0 & 0 & -1 & -1 & 0 & 0 & 2 & 0 & -1 & 0 & 0 \\ 0 & -1 & -1 & 0 & 0 & 2 & 0 & 0 & -1 & -1 & 0 & 0 & 2 & 1 & 0 & -1 & -2 & 0 & 0 & 1 & 1 & 0 & 0 & -2 & 0 & 0 & 1 & 1 & 0 & 0 & -2 & -1 & 0 & 1 & 2 & 0 \\ 0 & 0 & 1 & 1 & 0 & 0 & -2 & -1 & 0 & 1 & 2 & 0 & 0 & -1 & -1 & 0 & 0 & 2 & 0 & 0 & -1 & -1 & 0 & 0 & 2 & 1 & 0 & -1 & -2 & 0 & 0 & 1 & 1 & 0 & 0 & -2 \end{bmatrix} \quad (21)$$

$$W_{36-8} = \begin{bmatrix} 2 & 1 & 0 & 0 & -1 & -2 & 0 & 0 & 0 & 2 & 1 & 0 & 0 & -1 & -2 & 0 & 0 & 0 & 2 & 1 & 0 & 0 & -1 & -2 & 0 & 0 & 0 & 2 & 1 & 0 & 0 & -1 & -2 & 0 & 0 & 0 \\ 0 & 0 & 0 & 2 & 1 & 0 & 0 & -1 & -2 & 0 & 0 & 0 & 2 & 1 & 0 & 0 & -1 & -2 & 0 & 0 & 0 & 2 & 1 & 0 & 0 & -1 & -2 & 0 & 0 & 0 & 2 & 1 & 0 & 0 & -1 & -2 \\ 0 & -1 & -2 & 0 & 0 & 0 & 2 & 1 & 0 & 0 & -1 & -2 & 0 & 0 & 0 & 2 & 1 & 0 & 0 & -1 & -2 & 0 & 0 & 0 & 2 & 1 & 0 & 0 & -1 & -2 & 0 & 0 & 0 & 2 & 1 & 0 \end{bmatrix} \quad (22)$$

#### 4. Comparison with Finite Elements Simulations

The theoretical ZS inductance ratio is checked by 2D Finite Element (FE) simulations. Nevertheless, the conclusion would be not satisfactory if the effect of leakage flux is not considered. This is why several simulations have been performed with different air gap and magnetic permeability. The objective is to demonstrate that the simulation results tend close to the theoretical value when the leakage is minimized. The leakage is reduced by decreasing the air gap and increasing the magnetic permeability of the material. A fictive material has been introduced with a relative permeability of  $1e-6$ . The tables 1 et 2 show that the deviation is lower than 4% with an air gap of 0.1mm. In normal condition (air gap=0.8mm, real rotor, M330 magnetic material) the deviation is about 36%. This is explained by the leakage inductance. In proportion to the self inductance, the 36-8 machine has 16,44% of “pure” ZS inductance and 5,9% of leakage. In the same condition, the 36-10 machine has 27,27% of “pure” ZS inductance and 9% of leakage.

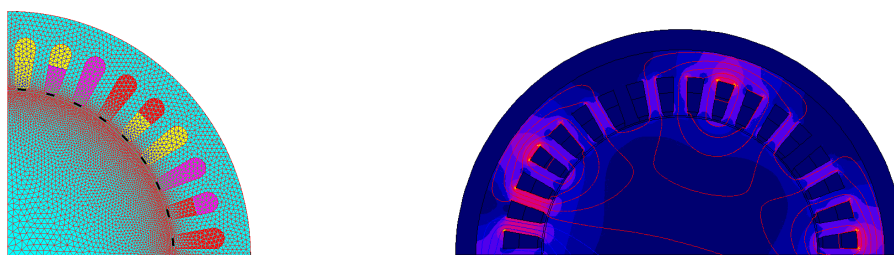

Fig. 9: 2D Finite Element Simutaion

**Table I: 36-10 Zero-Sequence Inductance Ratio evaluation in FE**

Air Gap	Rotor topology	Relative Permeability of the magnetic material	ZS inductance Ratio evaluation with FE	Deviation with the theoretical value
0.8mm	Radial magnets	M330	36,21%	+33%
0.8mm	Full rotor	1e6	31,53%	+16%
0.2mm	Full rotor	1e6	28,36%	+4%
0.1mm	Full rotor	1e6	27,83%	+2%

**Table II: 36-8 Zero-Sequence Inductance Ratio evaluation in FE**

Air Gap	Rotor topology	Relative Permeability of the magnetic material	ZS inductance Ratio evaluation with FE	Deviation with the theoretical value
0.8mm	Radial magnets	M330	25,91%	+36%
0.8mm	Full rotor	1e6	20,43%	+24%
0.2mm	Full rotor	1e6	17,46%	+6%
0.1mm	Full rotor	1e6	17,04%	+4%

Fig.10 shows for each machine that the measured ZS inductance ratio tends toward the theoretical value when the leakage flux is minimized. Except for the nominal case, these simulations have been carried out with a full rotor (no cutting for the magnets).

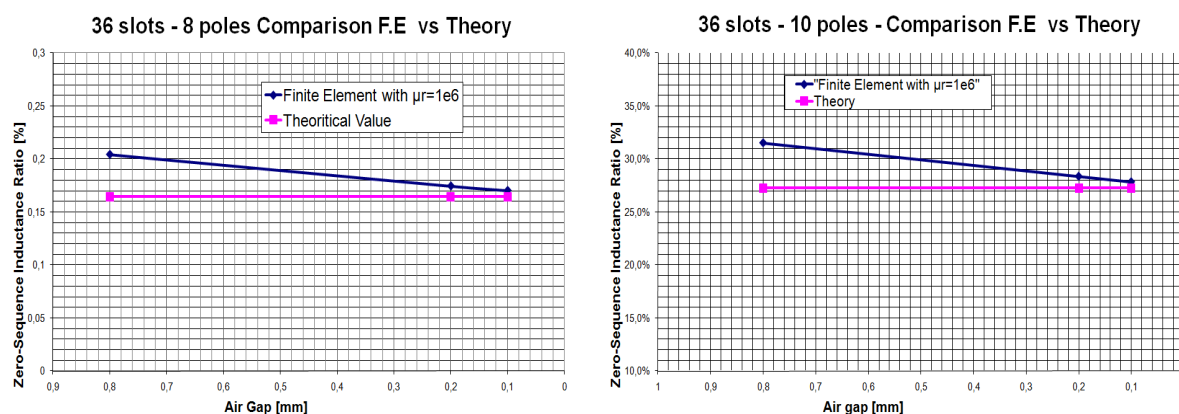

Fig. 11: ZS Inductance deviation : a) 36/8 b) 36/10

## Conclusion

The behavior of  $\Delta$  connected or Wye connected electric machines are well known. A topology able to combine the electric powertrain and the fast battery charger is proposed. Nevertheless, a 3H-bridge inverter is used. The H-bridges bring an additional degree of freedom but the design of the machine has to consider the zero-sequence inductance. This paper deals with machines having low or high zero-sequence inductance and a method is proposed to evaluate the theoretical zero-sequence inductance ratio. Some examples are given and confronted with Finite-Element simulations. The graphical or computational method is therefore able to give the zero-sequence inductance ratio and the normalized inductance matrix.

## References

- [1] L. De-Sousa, B. Bouchez, B. Silvestre: "A Combined Multiphase Electric Drive and Fast Battery Charger for Electric Vehicles", *IEEE Vehicle Power and Propulsion Conference (VPPC2010)*, Lille, France, Sept. 2010
- [2] L. Shi, A. Meintz, M. Ferdowski: "Single-Phase Bidirectional AC-DC Converters for Plug-in Hybrid Electric Vehicle Applications", *IEEE Vehicle Power and Propulsion Conference (VPPC08)*, Harbin, China, Sept. 2008
- [3] C. Stancu, S. Hiti, E. Mundt: "Modile Electric Power for Medium and Heavy Duty Hybrid Electric Vehicles", *35<sup>th</sup> IEEE Power Electronics Specialists Conference (PESC04)*, Aachen, Germany, 2004
- [4] Kinoshita Shigenori: "Electric System for Electric Vehicle", Japanese patent JP6276615, Fuji Electric Co LTD, Sept. 30, 1994
- [5] L. Solero: "Nonconventional on-board Charger for Electric Vehicle Propulsion Batteries", *IEEE Trans. on Vehicular Technology*, Vol. 50, NO. 1, Jan. 2001
- [6] S-K. Sul, S-J. Lee: "An Integral Battery Charger for Four-Wheel Drive Electric Vehicle", *IEEE Trans. on Industry Applications*, Vol. 31, NO. 5, Sept. 1995
- [7] S. Haghbin, M. Alakula, K. Khan, S. Lundmark, M. Leksell, O. Allmark, O. Carlson: "An integrated charger for Plug-in HEV based on a special interior permanent magnet motor", *IEEE Vehicle Power and Propulsion Conference (VPPC2010)*, Lille, France, Sept. 2010
- [8] L. De-Sousa, B. Bouchez: "Combined Electric Device for Powering and Charging", International Patent WO 2010/057892 A1
- [9] L. De-Sousa, B. Bouchez: "Method and Electric Combined Device for Powering and Charging with Compensation Means", International Patent WO 2010/057893 A1
- [10] A. Bruyère, L. De Sousa, B. Bouchez, P. Sandulescu, X. Kestelyn, E. Semail: "A multiphase traction/fast-battery-charger drive for EV and PHEV", *IEEE Vehicle Power and Propulsion Conference (VPPC2010)*, Lille, France, Sept. 2010
- [11] S. Lacroix, E. Laboure, M. Hilaret: "An integrated fast battery charger for EVs" *IEEE Vehicle Power and Propulsion Conference (VPPC2010)*, Lille, France, Sept. 2010
- [12] G. Dajaku and D. Gerling: "Skewing Effect on the PM Flux-Linkage High Harmonics of the PM Machine with Delta Winding", *IEEE Power Electronics and Applications Conference, EPE'09*, Barcelona, Spain, Sept. 2009
- [13] IEEE Standard 115-1995: "IEEE Guide: Test Procedure for Synchronous Machine", *Part II Test Procedure Determination for Dynamic Analysis*, page 104.

## Appendix

```

%-----Inductance Matrix Calculation M-File-----
%-----Luis DE SOUSA, IEEE Member -----
%
% This M-File (MATLAB) is able to compute the inductance matrix (M) and the Zero-Sequence Inductance ratio
function[M,MMF,N,P,Ls,Lo]=Inductance_Matrix(X);
% X is the winding matrix. The row represents the slots. Each value represents the normalized number of turns
N=size(X,2); % N is the number of slot
P=size(X,1); % M is the number of phase
x=X(:,1); % Phi
for k=1:N-1 x(:,k+1)=x(:,k)+X(:,1+k); end % Integration of the winding matrix ---> MMF matrix.
avg=sum(x,2)/N;
x=x-avg*ones(1,N); % The DC component is removed to obtain the flux
% the air gap mutual energy is calculated ( Flux(Phase x) X flux (Phase y))
for j=1:P; for k=1:P; M(j,k)=sum(x(j,:).*x(k,:),2); end; end;
% Normalized to the self inductance
Ls=M(1,1);
M=M/Ls;
MMF=x(1,:);
% Compute the Zero-Sequence Inductance
Lo= sum(sum(M))/P; end

```