



**HAL**  
open science

## Real Algebraic Geometry

Saugata Basu, Johannes Huisman, Kurdyka Krzysztof, Victoria Powers,  
Jean-Philippe Rolin

► **To cite this version:**

Saugata Basu, Johannes Huisman, Kurdyka Krzysztof, Victoria Powers, Jean-Philippe Rolin. Real Algebraic Geometry. Real Algebraic Geometry, Rennes, 2011, Jun 2011, Rennes, France. hal-00609687

**HAL Id: hal-00609687**

**<https://hal.science/hal-00609687v1>**

Submitted on 19 Jul 2011

**HAL** is a multi-disciplinary open access archive for the deposit and dissemination of scientific research documents, whether they are published or not. The documents may come from teaching and research institutions in France or abroad, or from public or private research centers.

L'archive ouverte pluridisciplinaire **HAL**, est destinée au dépôt et à la diffusion de documents scientifiques de niveau recherche, publiés ou non, émanant des établissements d'enseignement et de recherche français ou étrangers, des laboratoires publics ou privés.

# Conference Real Algebraic Geometry

**Université de Rennes 1**

**20 - 24 June 2011  
Beaulieu Campus**



Conference  
Real Algebraic Geometry

**Université de Rennes 1**

**20 - 24 june 2011  
Beaulieu Campus**



C'est un très grand plaisir pour nous d'accueillir à Rennes cette conférence internationale de Géométrie Algébrique Réelle qui est le quatrième opus d'une belle série commencée il y a 30 ans.

La toute première conférence internationale de la discipline fut organisée à Rennes en 1981 par Jean-Louis Colliot-Thélène, Michel Coste, Louis Mahé et Marie-Françoise Roy. Depuis, la discipline a pris un essor considérable : de très nombreuses conférences sur la thématique se sont déroulées dans le monde entier, un réseau européen a tissé des liens au cœur duquel Rennes 1 a toujours joué un rôle privilégié.

Le laboratoire de géométrie algébrique réelle rennais a acquis au fil des années une notoriété internationale et a poursuivi son travail de fond en organisant deux nouvelles conférences internationales de synthèse en 1991 puis en 2001.

Nous sommes donc particulièrement heureux de perpétuer cette tradition décennale d'excellence en ce mois de Juin 2011.

Nous voyons aussi en cette conférence l'occasion de rendre un hommage chaleureux aux professeurs Michel Coste, Louis Mahé et Marie-Françoise Roy pour la mise sur pieds et l'animation de l'équipe rennaise de recherche en Géométrie Algébrique Réelle ainsi que pour leur contribution scientifique marquante au renouveau de la thématique éponyme.

A l'avant veille — ou au lendemain matin pour l'un d'entre eux qui a pris un peu d'avance ! — de prendre un peu de distance avec leur fonction de mathématicien en exercice à Rennes 1, qu'ils reçoivent tout trois notre plus profonde considération.

Nous remercions les 150 chercheurs en mathématiques venus du monde entier pour assister à la conférence et notamment les participants qui vont y donner un exposé — grand merci au passage au comité scientifique. Notre gratitude va tout particulièrement aux conférenciers qui ont accepté le travail ingrat — mais ô combien utile pour la communauté — de rédiger pour la conférence un survol de leur discipline de prédilection : Saugata Basu, Johannes Huisman, Krzysztof Kurdyka, Victoria Powers et Jean-Philippe Rolin.

Nous souhaitons aussi remercier les nombreux sponsors qui nous ont permis d'accueillir autant de participants à des conditions avantageuses et notamment un aussi grand nombre de doctorants et post-doctorants appelés à constituer le vivier de la Géométrie Algébrique Réelle de demain. Merci donc à :

L'IRMAR, l'Université de Rennes 1, le CNRS, Rennes Métropole, le Conseil Régional, le Ministère de l'enseignement supérieur et de la recherche,

Et aussi tout particulièrement à :

La fondation Métivier, le GDR CNRS 2945 «Singularités et Applications», les deux supports IUF de Dominique Cerveau et d'Antoine Chambert-Loir, les ANR SIRE et ANR SIROPA.

Enfin, nous sommes fortement redevables envers Chantal Halet et Emmanuelle Guiot pour le travail considérable qu'elles ont déployé pour la bonne tenue de cette conférence.

Karim Bekka, Goulwen Fichou, Jean-Philippe Monnier, Ronan Quarez  
Organisateurs de la conférence RAG2011,  
Le 20 Juin 2011



It is a very big pleasure for us to welcome in Rennes this international conference in Real Algebraic Geometry which is the fourth opus of a beautiful series begun 30 years ago.

The very first international conference of the discipline was organized in Rennes in 1981 by Jean-Louis Colliot-Thélène, Michel Coste, Louis Mahé and Marie-Françoise Roy. Since then, the discipline took a considerable development: very numerous conferences on the theme took place all over the world, a European network forged ties the heart of which Rennes 1 always played a privileged role.

Over the years, the Rennes's real algebraic geometry laboratory acquired an international reputation and continued its thorough work by organizing two new international conferences of synthesis in 1991 then in 2001.

We are thus particularly happy to immortalize this ten-year tradition of excellence in this June 2011.

We also see in this conference the opportunity to pay a warm tribute to professors Michel Coste, Louis Mahé and Marie-Françoise Roy for the setting up and the animation of the Rennes's team of research in Real Algebraic Geometry as well as for their striking scientific contribution to the revival of the eponymic theme.

On the eve — or the following day morning for one of them who set a little beforehand ! — of setting a little outstrips with their position of mathematician in Rennes 1, may all three receive our deepest consideration.

We thank the 150 researchers in mathematics coming from all over world for attending the conference, in particular the participants who are going to give a talk — big thanks to the scientific committee. Our gratitude goes quite particularly to the speakers who accepted the thankless work - but how so useful for the community - to write for the conference a survey of their preferred discipline: Saugata Basu, Johannes Huisman, Krzysztof Kurdyka, Victoria Powers and Jean-Philippe Rolin.

We also wish to thank the numerous sponsors who allowed us to welcome so many participants under proper conditions, in particular a large number of PhD students and post-PhD students called to constitute the pool of the Real Algebraic Geometry of tomorrow. Thank you thus to:

The IRMAR, the university of Rennes 1, the CNRS, the Rennes Métropole, the Regional Council, the Ministry for Higher Education and Research, and particularly to:

The foundation Métivier, the GDR CNRS 2945 «Singularités et Applications», the two supports of the IUF of Dominique Cerveau and of Antoine Chambert-Loir, the ANR SIRE and ANR SIROPA.

Finally, we are deeply indebted to Chantal Halet and Emmanuelle Guiot for the considerable work they have done for the good running of this conference.

Karim Bekka, Goulwen Fichou, Jean-Philippe Monnier, Ronan Quarez  
Organizers of the conference RAG2011,  
June 20th, 2011





# CONTENTS

Five surveys on Real Algebraic Geometry.....	P.	11
➤ Algorithms in real algebraic geometry: a survey Saugata Basu.....	...P.	13
➤ Topology of real algebraic varieties; some recent results on rational surfaces Johannes Huisman.....	...P.	51
➤ Analytic arcs and real analytic singularities Krzysztof Kurdyka.....	...P.	63
➤ Positive Polynomials and Sums of Squares: Theory and Practice Victoria Powers.....	...P.	77
➤ A survey on o-minimal structures Jean-Philippe Rolin.....	...P.	105
Abstracts.....	P.	121
Participants.....	P.	141





**FIVE SURVEYS ON  
REAL ALGEBRAIC GEOMETRY**



## ALGORITHMS IN REAL ALGEBRAIC GEOMETRY: A SURVEY

SAUGATA BASU

ABSTRACT. We survey both old and new developments in the theory of algorithms in real algebraic geometry – starting from effective quantifier elimination in the first order theory of reals due to Tarski and Seidenberg, to more recent algorithms for computing topological invariants of semi-algebraic sets. We emphasize throughout the complexity aspects of these algorithms and also discuss the computational hardness of the underlying problems. We also describe some recent results linking the computational hardness of decision problems in the first order theory of the reals, with that of computing certain topological invariants of semi-algebraic sets. Even though we mostly concentrate on exact algorithms, we also discuss some numerical approaches involving semi-definite programming that have gained popularity in recent times.

## 1. INTRODUCTION

We survey developments in the theory of algorithms in real algebraic geometry – starting from the first effective quantifier elimination procedure due to Tarski and Seidenberg, to more recent work on efficient algorithms for quantifier elimination, as well as algorithms for computing topological invariants of semi-algebraic sets – such as the number semi-algebraically connected components, Euler-Poincaré characteristic, Betti numbers etc. Throughout the survey, the emphasis is on the worst-case complexity bounds of these algorithms, and the continuing effort to design algorithms with better complexity. Our goal in this survey is to describe these algorithmic results (including stating precise complexity bounds in most cases), and also give some indications of the techniques involved in designing these algorithms. We also describe some hardness results which show the intrinsic difficulty of some of these problems.

**1.1. Notation.** We first fix some notation. Throughout,  $\mathbb{R}$  will denote a *real closed field* (for example, the field  $\mathbb{R}$  of real numbers or  $\mathbb{R}_{\text{alg}}$  of real algebraic numbers), and we will denote by  $\mathbb{C}$  the algebraic closure of  $\mathbb{R}$ .

A *semi-algebraic subset* of  $\mathbb{R}^k$  is a set defined by a finite system of polynomial equalities and inequalities, or more generally by a Boolean formula whose atoms are polynomial equalities and inequalities. Given a finite set  $\mathcal{P}$  of polynomials in  $\mathbb{R}[X_1, \dots, X_k]$ , a subset  $S$  of  $\mathbb{R}^k$  is  *$\mathcal{P}$ -semi-algebraic* if  $S$  is the realization of a Boolean formula with atoms  $P = 0$ ,  $P > 0$  or  $P < 0$  with  $P \in \mathcal{P}$  (we will call such a formula a quantifier-free  $\mathcal{P}$ -formula).

---

*Key words and phrases.* Algorithms, Complexity, Semi-algebraic Sets, Betti Numbers .

2000 MATHEMATICS SUBJECT CLASSIFICATION PRIMARY 14P10, 14P25; SECONDARY 68W30

It is clear that for every semi-algebraic subset  $S$  of  $\mathbb{R}^k$  there exists a finite set  $\mathcal{P}$  of polynomials in  $\mathbb{R}[X_1, \dots, X_k]$  such that  $S$  is  $\mathcal{P}$ -semi-algebraic. We call a semi-algebraic set a  **$\mathcal{P}$ -closed** semi-algebraic set if it is defined by a Boolean formula with no negations with atoms  $P = 0$ ,  $P \geq 0$ , or  $P \leq 0$  with  $P \in \mathcal{P}$ .

For an element  $a \in \mathbb{R}$  we let

$$\text{sign}(a) = \begin{cases} 0 & \text{if } a = 0, \\ 1 & \text{if } a > 0, \\ -1 & \text{if } a < 0. \end{cases}$$

A **sign condition** on  $\mathcal{P}$  is an element of  $\{0, 1, -1\}^{\mathcal{P}}$ . For any semi-algebraic set  $Z \subset \mathbb{R}^k$  the **realization of the sign condition  $\sigma$  over  $Z$** ,  $\mathcal{R}(\sigma, Z)$ , is the semi-algebraic set

$$\{x \in Z \mid \bigwedge_{P \in \mathcal{P}} \text{sign}(P(x)) = \sigma(P)\},$$

and in case  $Z = \mathbb{R}^k$  we will denote  $\mathcal{R}(\sigma, Z)$  by just  $\mathcal{R}(\sigma)$ .

If  $\mathcal{P}$  is a finite subset of  $\mathbb{R}[X_1, \dots, X_k]$ , we write the set of zeros of  $\mathcal{P}$  in  $\mathbb{R}^k$  as

$$Z(\mathcal{P}, \mathbb{R}^k) = \{x \in \mathbb{R}^k \mid \bigwedge_{P \in \mathcal{P}} P(x) = 0\}.$$

Given a semi-algebraic set  $S \subset \mathbb{R}^k$ , we will denote by  $b_i(S)$  the  $i$ -th **Betti number** of  $S$ , that is the rank of the  $i$ -th homology group of  $S$  (see [17] for precise definitions of homology groups for semi-algebraic sets defined over arbitrary real closed fields). Note that  $b_0(S)$  is the number of semi-algebraically connected components of  $S$ . We will denote by  $b(S)$  the sum  $\sum_{i \geq 0} b_i(S)$ .

For  $x \in \mathbb{R}^k$  and  $r > 0$ , we will denote by  $B_k(x, r)$  (resp.  $\mathbf{S}^{k-1}(x, r)$ ) the open ball (resp. the sphere) with center  $x$  and radius  $r$  in  $\mathbb{R}^k$ . When  $x = 0$ , we will write  $B_k(r)$  (resp.  $\mathbf{S}^{k-1}(r)$ ) instead of  $B_k(0, r)$  (resp.  $\mathbf{S}^{k-1}(0, r)$ ). We will also denote the unit ball (resp. sphere) in  $\mathbb{R}^k$  centered at 0 by  $B_k$  (resp.  $\mathbf{S}^{k-1}$ ).

**1.2. Main algorithmic problems.** Algorithmic problems in semi-algebraic geometry typically consist of the following. We are given as input a finite family,  $\mathcal{P} \subset \mathbb{D}[X_1, \dots, X_k]$ , where  $\mathbb{D}$  is an ordered domain contained in the real closed field  $\mathbb{R}$ . The main algorithmic problems can be roughly divided into two classes (though we will see later in Section 3.4 how they are related from the point of computational complexity).

The first class of problems has a logical flavor. It includes the following.

Given a quantified  $\mathcal{P}$ -formula  $\Phi$  (with or without free variables), the task is to:

- (1) (**The Quantifier Elimination Problem**) Compute a quantifier-free formula equivalent to  $\Phi$ .
- (2) (**The General Decision Problem**) This is a special case of the previous problem when  $\Phi$  has no free variables, and the problem is to decide the truth or falsity of  $\Phi$ .
- (3) (**The Existential Problem**) This is a special case of the last problem when there is exactly one block of existential quantifiers; equivalently, the problem can be stated as deciding whether a given  $\mathcal{P}$ -semi-algebraic set is empty or not.

The second class of problems has a more geometric and/or topological flavor. Given a description of a  $\mathcal{P}$ -semi-algebraic set  $S \subset \mathbb{R}^k$  the task is to decide whether

certain geometric and topological properties hold for  $S$ , and in some cases also computing certain topological invariants of  $S$ . Some of the most basic problems include the following.

- (1) (**Deciding Emptiness**) Decide whether  $S$  is empty or not (this is the same as the Existential Problem described above).
- (2) (**Deciding Connectivity**) Given two points  $x, y \in S$ , decide if they are in the same semi-algebraically connected component of  $S$  and if so output a semi-algebraic path in  $S$  connecting them.
- (3) (**Describing Connected Components**) Compute semi-algebraic descriptions of the semi-algebraically connected components of  $S$ .

At a slightly deeper level we have problems of a more topological flavor, such as:

- (4) (**Computing Betti Numbers**) Compute the cohomology groups of  $S$ , its Betti numbers, its Euler-Poincaré characteristic etc..
- (5) (**Computing Triangulations**) Compute a semi-algebraic triangulation of  $S$  as well as,
- (6) (**Computing Regular Stratifications**) compute a decomposition of  $S$  into semi-algebraic smooth pieces of various dimensions satisfying certain extra regularity conditions ( for example, Whitney conditions (a) and(b)).

**Definition 1.1** (Complexity). A typical input to the algorithms considered in this survey will be a set of polynomials with coefficients in an ordered ring  $D$  (which can be taken to be the ring generated by the coefficients of the input polynomials). By **complexity of an algorithm** we will mean the number of arithmetic operations (including comparisons) performed by the algorithm in the ring  $D$ . In case the input polynomials have integer coefficients with bounded bit-size, then we will often give the bit-complexity, which is the number of bit operations performed by the algorithm. We refer the reader to [17, Chapter 8] for a full discussion about the various measures of complexity.

The complexity of an algorithm (see Definition 1.1 above) for solving any of the above problems is measured in terms of the following three parameters:

- the number of polynomials,  $s = \text{card } \mathcal{P}$ ,
- the maximum degree,  $d = \max_{P \in \mathcal{P}} \deg(P)$ , and
- the number of variables,  $k$  (and in case of quantifier elimination problems, the block decomposition of the  $k$  variables).

The rest of the paper is organized as follows. In Section 2, we describe known algorithms for quantifier elimination in the theory of the reals, starting from Tarski's algorithm, algorithms via cylindrical algebraic decomposition, and finally more modern algorithms using the critical points method. We also discuss some variants of quantifier elimination problem that arise in applications, as well as certain approaches using complex geometry of polar varieties that give efficient probabilistic algorithms. We also discuss the known lower bounds for real quantifier elimination.

In Section 3, we concentrate on algorithms for computing topological properties of semi-algebraic sets – including connectivity property via construction of roadmaps, computing the generalized Euler-Poincaré characteristic of semi-algebraic sets, as well as computing the Betti numbers of semi-algebraic sets. Throughout this section the emphasis is on algorithms with singly exponential complexity bounds. We also discuss certain results that are special to semi-algebraic sets defined by quadratic inequalities, or more generally where the defining polynomials have at most



quadratic dependence on most of the variables. We also point out the significance of some of the results from the point of view of computational complexity theory. Finally, we discuss a recent reduction result linking the complexity of the problem of computing the Betti numbers of semi-algebraic sets, with that of the decision problem in the first order theory of the real with a fixed number of quantifier block.

In Section 4, we discuss numerical algorithms for polynomial optimization using the “sums-of-square” approach. The main algorithmic tool here is “interior-point algorithms for semi-definite programming” and we discuss the known results on the computational complexity of the semi-definite programming problem.

We end with a list of open problems (Section 5).

*Warning.* There are several interesting topics which come under the purview of algorithms in real algebraic geometry that have been left out of this survey (because of lack of space as well as the author’s lack of expertise in some of these topics). For example, we do not make any attempt to survey the extremely broad area of research concerning efficient implementation of theoretically efficient algorithms, specific low dimensional applications such as computing the topology of curves and surfaces, computing certificates of positivity of polynomials (for archimedean as well as non-archimedean real closed fields), homotopy continuation algorithms for solving real systems etc. There are multiple excellent sources available for most of these topics. Finally, algorithmic real algebraic geometry has a great variety of applications, due to the ubiquity of semi-algebraic sets arising in different areas of science and engineering – including robotics, molecular chemistry, theoretical computer science, database theory etc. We do not make any attempt to survey these applications.

## 2. QUANTIFIER ELIMINATION AND RELATED PROBLEMS

We begin appropriately with the first algorithm (in the modern sense) in real algebraic geometry which is a starting point of the subject.

### 2.1. The Tarski-Seidenberg Theorem and effective quantifier elimination.

Let  $\mathcal{P} = \{P_1, \dots, P_s\} \subset \mathbb{R}[X_1, \dots, X_k, Y_1, \dots, Y_\ell]$ , and  $\Phi(Y)$  a first-order formula given by

$$(Q_\omega X^{[\omega]}) \dots (Q_1 X^{[1]}) F(P_1, \dots, P_s),$$

where  $Q_i \in \{\forall, \exists\}$ ,  $Q_i \neq Q_{i+1}$ ,  $Y = (Y_1, \dots, Y_\ell)$  is a block of  $\ell$  free variables,  $X^{[i]}$  is a block of  $k_i$  variables with  $\sum_{1 \leq i \leq \omega} k_i = k$ , and  $F(P_1, \dots, P_s)$  is a quantifier-free Boolean formula with atomic predicates of the form  $\text{sign}(P_i(Y, X^{[\omega]}, \dots, X^{[1]})) = \sigma$  where  $\sigma \in \{0, 1, -1\}$ . (Letting  $\Pi$  denote the partition of the blocks of variables  $X_1, \dots, X_k$  into the  $\omega$  blocks of sizes  $k_1, \dots, k_\omega$ , we call a formula such as  $\Phi$ , having the block structure specified by  $\Pi$  to be a  $(\mathcal{P}, \Pi)$ -formula.)

The Tarski-Seidenberg theorem states that

**Theorem 2.1.** [74] *There exists a quantifier-free formula,  $\Psi(Y)$ , such that for any  $y \in \mathbb{R}^\ell$ ,  $\Phi(y)$  is true if and only if  $\Psi(y)$  is true.*

The quantifier elimination problem is to algorithmically construct such a formula.

2.1.1. *Algorithm arising from Tarski's proof.* Tarski's proof [74] of the existence of quantifier elimination in the theory of the reals was effective and was based on Sturm's theorem for counting real roots of polynomials in one variable with real coefficients used in a parametric way. A modern treatment of this proof can be found in [17, Chapter 2]. The complexity of this procedure was not formally analysed in Tarski's paper. However, the algorithm eliminates one variable at a time using a parametrized version of Euclidean remainder sequence, and as a result the number and degrees of the polynomials in the remaining variables grow rather fast, and it is not possible to bound the complexity of the algorithm by any function which is a tower of exponents (in the input parameters) of a fixed height, which implies that the complexity of Tarski's algorithm is not *elementary recursive*. An elementary recursive algorithm for the General Decision Problem was found later by Monk [56].

2.1.2. *Cylindrical Algebraic Decomposition.* One fundamental technique for computing topological invariants of semi-algebraic sets is through *Cylindrical Algebraic Decomposition*. Even though the mathematical ideas behind cylindrical algebraic decomposition were known before (see for example [54]), Collins [35, 36] was the first to apply cylindrical algebraic decomposition in the setting of algorithmic semi-algebraic geometry. Schwartz and Sharir [72] realized its importance in trying to solve the motion planning problem in robotics, as well as computing topological properties of semi-algebraic sets. Similar ideas leading to doubly exponential algorithms was also developed by Wüthrich [77].

**Definition 2.2** (Cylindrical Algebraic Decomposition). A *cylindrical algebraic decomposition* of  $\mathbb{R}^k$  is a sequence  $\mathcal{S}_1, \dots, \mathcal{S}_k$  where, for each  $1 \leq i \leq k$ ,  $\mathcal{S}_i$  is a finite partition of  $\mathbb{R}^i$  into semi-algebraic subsets, called the cells of level  $i$ , which satisfy the following properties:

- Each cell  $S \in \mathcal{S}_1$  is either a point or an open interval.
- For every  $1 \leq i < k$  and every  $S \in \mathcal{S}_i$ , there are finitely many continuous semi-algebraic functions

$$\xi_{S,1} < \dots < \xi_{S,\ell_S} : S \longrightarrow \mathbb{R}$$

such that the cylinder  $S \times \mathbb{R} \subset \mathbb{R}^{i+1}$  is the disjoint union of cells of  $\mathcal{S}_{i+1}$  which are:

- either the graph of one of the functions  $\xi_{S,j}$ , for  $j = 1, \dots, \ell_S$ :

$$\{(x', x_{j+1}) \in S \times \mathbb{R} \mid x_{j+1} = \xi_{S,j}(x')\},$$

- or a band of the cylinder bounded from below and from above by the graphs of the functions  $\xi_{S,j}$  and  $\xi_{S,j+1}$ , for  $j = 0, \dots, \ell_S$ , where we take  $\xi_{S,0} = -\infty$  and  $\xi_{i,\ell_S+1} = +\infty$ :

$$\{(x', x_{j+1}) \in S \times \mathbb{R} \mid \xi_{S,j}(x') < x_{j+1} < \xi_{S,j+1}(x')\}.$$

**Definition 2.3.** Given a finite set  $\mathcal{P} \subset \mathbb{R}[X_1, \dots, X_k]$ , a subset  $S$  of  $\mathbb{R}^k$  is  *$\mathcal{P}$ -invariant* if every polynomial  $P \in \mathcal{P}$  has a constant sign ( $> 0$ ,  $< 0$ , or  $= 0$ ) on  $S$ . A *cylindrical algebraic decomposition of  $\mathbb{R}^k$  adapted to  $\mathcal{P}$*  is a cylindrical algebraic decomposition for which each cell  $C \in \mathcal{S}_k$  is  $\mathcal{P}$ -invariant. It is clear that if  $S$  is  $\mathcal{P}$ -semi-algebraic, a cylindrical algebraic decomposition adapted to  $\mathcal{P}$  is a cylindrical algebraic decomposition adapted to  $S$ .

One important result which underlies most algorithmic applications of cylindrical algebraic decomposition is the following (see [17, Chapter 11] for an easily accessible exposition).

**Theorem 2.4.** [36, 77] *For every finite set  $\mathcal{P}$  of polynomials in  $\mathbb{R}[X_1, \dots, X_k]$ , there is a cylindrical decomposition of  $\mathbb{R}^k$  adapted to  $\mathcal{P}$ . Moreover, such a decomposition can be computed in time  $(sd)^{2^{O(k)}}$ , where  $s = \text{card } \mathcal{P}$  and  $d = \max_{P \in \mathcal{P}} \deg(P)$ .*

Cylindrical algebraic decomposition provides an alternative (and more efficient compared to Tarski's) algorithm for quantifier elimination, since (using the same notation as in the previous section) the semi-algebraic subset of  $\mathbb{R}^\ell$  defined by  $\Phi(Y)$ , is a union of cells (of various dimensions) in a cylindrical algebraic decomposition of  $\mathbb{R}^{k+\ell}$  adapted to  $\mathcal{P}$  (cf. Definition 2.3), where  $Y_1, \dots, Y_\ell$  are the last  $\ell$  variables. This last fact is a consequence of the “cylindrical” structure of the decomposition. The complexity of such an algorithm is bounded by the complexity of computing the cylindrical decomposition and is doubly exponential. More precisely, the complexity is bounded by  $(sd)^{2^{O(k+\ell)}}$ .

*Remark 2.5.* The technique of cylindrical algebraic decomposition is also used in algorithms for computing topological properties of semi-algebraic sets. After making a generic linear change of co-ordinates, the cylindrical algebraic decomposition algorithm yields a finite cell complex from which topological invariants of the underlying semi-algebraic sets can be extracted. It should be noted that a change of co-ordinates is needed to obtain a cell complex. However, in certain applications a change of co-ordinates is not allowed (see [22] for one such application). It is an interesting open question if there always exists a semi-algebraic cell decomposition adapted to a given finite family of polynomials, having a cylindrical structure with respect to the given co-ordinates.

**2.1.3. Lower bound.** Given the doubly exponential upper bound on the complexity of quantifier elimination algorithm that follows from cylindrical algebraic decomposition, it is interesting to ask whether it is at all possible to do better. This question was investigated by Davenport and Heintz [40] who proved a doubly exponential *lower bound* on the complexity of real quantifier elimination, by constructing a sequence of quantified formula having the property that any equivalent sequence of quantifier-free formulas would necessarily have doubly exponential growth in size. However, the quantified formulas in the sequence they constructed had a large number of quantifier alternations (linear in the number of variables). Thus, while it is impossible to hope for better than doubly exponential dependence in the number,  $\omega$ , of quantifier alternations, it might still be possible to obtain algorithms with much better complexity (i.e. singly exponential in the number of variables) if we fix the number of quantifier alternations. This is what we describe next.

**2.2. The critical points method and singly exponential algorithms.** As mentioned earlier, all algorithms using cylindrical algebraic decomposition have doubly exponential complexity. Algorithms with singly exponential complexity for solving problems in semi-algebraic geometry are mostly based on the *critical points method*. This method was pioneered by several researchers including Grigoriev and Vorobjov [46, 45], Renegar [67], Canny [33], Heintz, Roy and Solernò [48], Basu, Pollack and Roy [12] amongst others. In simple terms, the *critical points*

*method* is nothing but a method for finding at least one point in every semi-algebraically connected component of an algebraic set. It can be shown that for a bounded nonsingular algebraic hyper-surface, it is possible to change coordinates so that its projection to the  $X_1$ -axis has a finite number of non-degenerate critical points. These points provide at least one point in every semi-algebraically connected component of the bounded nonsingular algebraic hyper-surface. Unfortunately this is not very useful in algorithms since it provides no method for performing this linear change of variables. Moreover when we deal with the case of a general algebraic set, which may be unbounded or singular, this method no longer works.

In order to reduce the general case to the case of bounded nonsingular algebraic sets, we use an important technique in algorithmic semi-algebraic geometry – namely, perturbation of a given real algebraic set in  $\mathbb{R}^k$  using one or more infinitesimals. The perturbed variety is then defined over a non-archimedean real closed extension of the ground field – namely the field of algebraic Puiseux series in the infinitesimal elements with coefficients in  $\mathbb{R}$ .

Since the theory behind such extensions might be unfamiliar to some readers, we introduce here the necessary algebraic background referring the reader to [17, Section 2.6] for full detail and proofs.

2.2.1. *Infinitesimals and the field of algebraic Puiseux series.*

**Definition 2.6** (Puiseux series). A *Puiseux series* in  $\varepsilon$  with coefficients in  $\mathbb{R}$  is a series of the form

$$(2.1) \quad \bar{a} = \sum_{i \geq k} a_i \varepsilon^{i/q},$$

with  $k \in \mathbb{Z}$ ,  $i \in \mathbb{Z}$ ,  $a_i \in \mathbb{R}$ ,  $q$  a positive integer.

It is a straightforward exercise to verify that the field of all Puiseux series in  $\varepsilon$  with coefficients in  $\mathbb{R}$  is an ordered field. The order extends the order of  $\mathbb{R}$ , and  $\varepsilon$  is an infinitesimally small and positive, i.e. is positive and smaller than any positive  $r \in \mathbb{R}$ .

NOTATION 1. The field of Puiseux series in  $\varepsilon$  with coefficients in  $\mathbb{R}$  contains as a subfield, the field of Puiseux series which are algebraic over  $\mathbb{R}[\varepsilon]$ . We denote by  $\mathbb{R}\langle\varepsilon\rangle$  the *field of algebraic Puiseux series* in  $\varepsilon$  with coefficients in  $\mathbb{R}$ . We will also use the notation  $\mathbb{R}\langle\varepsilon_1, \dots, \varepsilon_m\rangle$  to denote the field  $\mathbb{R}\langle\varepsilon_1\rangle \cdots \langle\varepsilon_m\rangle$ . Notice that in the field  $\mathbb{R}\langle\varepsilon_1, \dots, \varepsilon_m\rangle$  we have the ordering  $0 < \varepsilon_m \ll \varepsilon_{m-1} \ll \cdots \ll \varepsilon_1 \ll 1$  where the symbol  $a \ll b$  means that  $a$  is infinitesimally small with respect to  $b$ .

The following theorem is classical (see for example [17, Section 2.6] for a proof).

**Theorem 2.7.** *The field  $\mathbb{R}\langle\varepsilon\rangle$  is real closed.*

**Definition 2.8** (The  $\lim_\varepsilon$  map). When  $a \in \mathbb{R}\langle\varepsilon\rangle$  is bounded by an element of  $\mathbb{R}$ ,  $\lim_\varepsilon(a)$  is the constant term of  $a$ , obtained by substituting 0 for  $\varepsilon$  in  $a$ .

**Example 2.9.** A typical example of the application of the  $\lim$  map can be seen in Figures 1 and 2 below. The first picture depicts the algebraic set  $Z(Q, \mathbb{R}^3)$ , while the second depicts the algebraic set  $Z(\text{Def}(Q, \zeta, 4), \mathbb{R}\langle\zeta\rangle^3)$  (where we substituted a very small positive number for  $\zeta$  in order to able display this set), where  $Q$  and

$\text{Def}(Q, \zeta, 4)$  are defined by Eqn. (2.4) and Eqn. (2.3) respectively. The algebraic sets  $Z(Q, \mathbb{R}^3)$  and  $Z(\text{Def}(Q, \zeta, 4), \mathbb{R}\langle\zeta\rangle^3)$  are related by

$$Z(Q, \mathbb{R}^3) = \lim_{\zeta} Z(\text{Def}(Q, \zeta, 4), \mathbb{R}\langle\zeta\rangle^3).$$

Since we will often consider the semi-algebraic sets defined by the same formula, but over different real closed extensions of the ground field, the following notation is useful.

NOTATION 2. Let  $\mathbb{R}'$  be a real closed field containing  $\mathbb{R}$ . Given a semi-algebraic set  $S$  in  $\mathbb{R}^k$ , the *extension* of  $S$  to  $\mathbb{R}'$ , denoted  $\text{Ext}(S, \mathbb{R}')$ , is the semi-algebraic subset of  $\mathbb{R}'^k$  defined by the same quantifier free formula that defines  $S$ .

The set  $\text{Ext}(S, \mathbb{R}')$  is well defined (i.e. it only depends on the set  $S$  and not on the quantifier free formula chosen to describe it). This is an easy consequence of the transfer principle.

We now return to the discussion of the critical points method. In order for the critical points method to work for all algebraic sets, we associate to a possibly unbounded algebraic set  $Z \subset \mathbb{R}^k$  a bounded algebraic set  $Z_b \subset \mathbb{R}\langle\varepsilon\rangle^{k+1}$ , whose semi-algebraically connected components are closely related to those of  $Z$ .

Let  $Z = Z(Q, \mathbb{R}^k)$  and consider

$$Z_b = Z(Q^2 + (\varepsilon^2(X_1^2 + \dots + X_{k+1}^2) - 1)^2, \mathbb{R}\langle\varepsilon\rangle^{k+1}).$$

The variety  $Z_b$  is the intersection of the sphere  $S^k(0, 1/\varepsilon)$  of center 0 and radius  $\frac{1}{\varepsilon}$  with a cylinder based  $\text{Ext}(Z, \mathbb{R}\langle\varepsilon\rangle)$  (and is hence bounded over  $\mathbb{R}\langle\varepsilon\rangle$ ). The intersection of  $Z_b$  with the hyper-plane  $X_{k+1} = 0$  is the intersection of  $Z$  with the sphere  $S^{k-1}(0, 1/\varepsilon)$  of center 0 and radius  $\frac{1}{\varepsilon}$ . Denote by  $\pi$  the projection from  $\mathbb{R}\langle\varepsilon\rangle^{k+1}$  to  $\mathbb{R}\langle\varepsilon\rangle^k$ .

The following proposition which appears in [17] then relates the semi-algebraically connected component of  $Z$  with those of  $Z_b$  and this allows us to reduce the problem of finding points on every semi-algebraically connected component of a possibly unbounded algebraic set to the same problem on bounded algebraic sets.

**Proposition 2.10.** *Let  $N$  be a finite number of points meeting every semi-algebraically connected component of  $Z_b$ . Then  $\pi(N)$  meets every semi-algebraically connected component of the extension  $\text{Ext}(Z, \mathbb{R}\langle\varepsilon\rangle)$ .*

We obtain immediately using Proposition 2.10 a method for finding a point in every semi-algebraically connected component of an algebraic set. Note that these points have coordinates in the extension  $\mathbb{R}\langle\varepsilon\rangle$  rather than in the real closed field  $\mathbb{R}$  we started with. However, the extension from  $\mathbb{R}$  to  $\mathbb{R}\langle\varepsilon\rangle$  preserves semi-algebraically connected components.

2.2.2. *Representation of points.* One important aspect in any algorithm in real algebraic geometry is how to represent points whose co-ordinates belong to some real algebraic extension of the ordered ring  $\mathbb{D}$  generated by the coefficients of the input polynomials. There are as usual several options, such as representing an arbitrary real algebraic number using isolating intervals, or by Thom encodings etc. In the singly-exponential algorithms described in the book [17], points in  $\mathbb{R}^k$  are represented by *univariate representations* and an associated *Thom encoding*.

Even though we will not need any further detail about these representations in this survey, given their importance in most of the algorithms that we refer to, we include their precise definitions below.

**Definition 2.11** (Thom encoding). Let  $P \in \mathbb{R}[X]$  and  $\sigma \in \{0, 1, -1\}^{\text{Der}(P)}$ , a sign condition on the set  $\text{Der}(P)$  of derivatives of  $P$ . The sign condition  $\sigma$  is a **Thom encoding** of  $x \in \mathbb{R}$  if  $\sigma(P) = 0$  and  $\sigma$  is the sign condition taken by the set  $\text{Der}(P)$  at  $x$ . Given a Thom encoding  $\sigma$ , we denote by  $x(\sigma)$  the root of  $P$  in  $\mathbb{R}$  specified by  $\sigma$ .

(Note that the use of Thom encoding to represent algebraic numbers was introduced in algorithmic real algebraic geometry by Coste and Roy in [37].)

**Definition 2.12** (Univariate representations and real univariate representations). A  **$k$ -univariate representation** is a  $k + 2$ -tuple of polynomials of  $\mathbb{R}[T]$ ,

$$(f(T), g_0(T), g_1(T), \dots, g_k(T)),$$

such that  $f$  and  $g_0$  are coprime.

The **points associated** to a univariate representation are the points

$$\left( \frac{g_1(t)}{g_0(t)}, \dots, \frac{g_k(t)}{g_0(t)} \right) \in \mathbb{C}^k$$

where  $t \in \mathbb{C}$  is a root of  $f(T)$ .

A **real  $k$ -univariate representation** is a pair  $u, \sigma$  where  $u$  is a  $k$ -univariate representation and  $\sigma$  is the Thom encoding of a root of  $f$ ,  $t_\sigma \in \mathbb{R}$ . The **point associated** to the real univariate representation is the point

$$\left( \frac{g_1(t_\sigma)}{g_0(t_\sigma)}, \dots, \frac{g_k(t_\sigma)}{g_0(t_\sigma)} \right) \in \mathbb{R}^k.$$

*Remark 2.13.* By parametrizing the definition of a real  $k$ -univariate representation (lets say by a co-ordinate function such as  $X_1$ ) one obtains descriptions of semi-algebraic curves. These **curve segment representations** play an important role in algorithms for computing roadmaps of semi-algebraic sets (see Section 3.1 below).

**2.2.3. Deformation techniques to deal with singular varieties.** For dealing with possibly singular algebraic sets we define  **$X_1$ -pseudo-critical points** of  $Z(Q, \mathbb{R}^k)$  when  $Z(Q, \mathbb{R}^k)$  is a bounded algebraic set. These pseudo-critical points are a finite set of points meeting every semi-algebraically connected component of  $Z(Q, \mathbb{R}^k)$ . They are the limits of the critical points of the projection to the  $X_1$  coordinate of a bounded nonsingular algebraic hyper-surface defined by a particular infinitesimal perturbation,  $\text{Def}(Q, \zeta, d)$ , of the polynomial  $Q$  (where  $d = \deg(Q)$ ). Moreover, the equations defining the critical points of the projection on the  $X_1$  coordinate on the perturbed algebraic set have a very special algebraic structure (they form a Gröbner basis [17, Section 12.1]), which makes possible efficient computation of these pseudo-critical values and points. We refer the reader to [17, Chapter 12] for a full exposition including the definition and basic properties of Gröbner basis.

The deformation  $\text{Def}(Q, \zeta, d)$  of  $Q$  is defined as follows. Suppose that  $Z(Q, \mathbb{R}^k)$  is contained in the ball of center 0 and radius  $1/c$ . Let  $\bar{d}$  be an even integer bigger than the degree  $d$  of  $Q$  and let

$$(2.2) \quad G_k(\bar{d}, c) = c^{\bar{d}}(X_1^{\bar{d}} + \dots + X_k^{\bar{d}} + X_2^2 + \dots + X_k^2) - (2k - 1),$$

$$(2.3) \quad \text{Def}(Q, \zeta, d) = \zeta G_k(\bar{d}, c) + (1 - \zeta)Q.$$

The algebraic set  $Z(\text{Def}(Q, \zeta, d), \mathbb{R}\langle \zeta \rangle^k)$  is a bounded and non-singular hypersurface lying infinitesimally close to  $Z(Q, \mathbb{R}^k)$  and the critical points of the projection map onto the  $X_1$  co-ordinate restricted to  $Z(\text{Def}(Q, \zeta, d), \mathbb{R}\langle \zeta \rangle^k)$  form a finite set of points. We take the images of these points under  $\lim_{\zeta}(\cdot)$  (cf. Definition 2.8) and we call the points obtained in this manner the  $X_1$ -pseudo-critical points of  $Z(Q, \mathbb{R}^k)$ . Their projections on the  $X_1$ -axis are called pseudo-critical values.

**Example 2.14.** We illustrate the perturbation mentioned above by a concrete example. Let  $k = 3$  and  $Q \in \mathbb{R}[X_1, X_2, X_3]$  be defined by

$$(2.4) \quad Q = X_2^2 - X_1^2 + X_1^4 + X_2^4 + X_3^4.$$

Then,  $Z(Q, \mathbb{R}^3)$  is a bounded algebraic subset of  $\mathbb{R}^3$  shown below in Figure 1. Notice that  $Z(Q, \mathbb{R}^3)$  has a singularity at the origin. The surface  $Z(\text{Def}(Q, \zeta, 4), \mathbb{R}\langle \zeta \rangle^3)$  with a small positive real number substituted for  $\zeta$  is shown in Figure 2. Notice that this surface is non-singular, but has a different semi-algebraic homotopy type than  $Z(Q, \mathbb{R}\langle \zeta \rangle^3)$  (it has three semi-algebraically connected components compared to only one of  $Z(Q, \mathbb{R}\langle \zeta \rangle^3)$ ). However, the semi-algebraic set bounded by  $Z(\text{Def}(Q, \zeta, 4), \mathbb{R}\langle \zeta \rangle^3)$  (i.e. the part inside the larger component but outside the smaller ones) is semi-algebraically homotopy equivalent to  $Z(Q, \mathbb{R}\langle \zeta \rangle^3)$ .

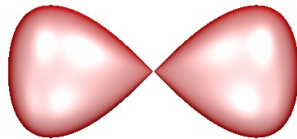

FIGURE 1. The algebraic set  $Z(Q, \mathbb{R}^3)$ .

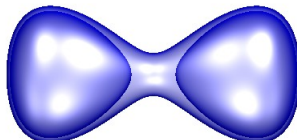

FIGURE 2. The algebraic set  $Z(\text{Def}(Q, \zeta, 4), \mathbb{R}^3)$ .

By computing algebraic representations (see [17, Section 12.4] for the precise definition of such a representation) of the pseudo-critical points one obtains for any given algebraic set a finite set of points guaranteed to meet every semi-algebraically connected component of this algebraic set. Using some more arguments from real algebraic geometry one can also reduce the problem of computing a finite set of points guaranteed to meet every semi-algebraically connected component of the realization of every realizable sign condition on a given family of polynomials to finding points on certain algebraic sets defined by the input polynomials (or infinitesimal perturbations of these polynomials). The details of this argument can be found in [17, Proposition 13.2].

The following theorem which is the best result of this kind appears in [13].

**Theorem 2.15.** *Let  $Z(Q, \mathbb{R}^k)$  be an algebraic set of real dimension  $k'$ , where  $Q$  is a polynomial in  $\mathbb{R}[X_1, \dots, X_k]$  of degree at most  $d$ , and let  $\mathcal{P} \subset \mathbb{R}[X_1, \dots, X_k]$  be a set of  $s$  polynomials with each  $P \in \mathcal{P}$  also of degree at most  $d$ . Let  $D$  be the ring generated by the coefficients of  $Q$  and the polynomials in  $\mathcal{P}$ . There is an algorithm which computes a set of points meeting every semi-algebraically connected component of every realizable sign condition on  $\mathcal{P}$  over  $Z(Q, \mathbb{R}(\varepsilon, \delta)^k)$ . The algorithm has complexity*

$$(k'(k - k') + 1) \sum_{j \leq k'} 4^j \binom{s}{j} d^{O(k)} = s^{k'} d^{O(k)}$$

*in  $D$ . There is also an algorithm providing the list of signs of all the polynomials of  $\mathcal{P}$  at each of these points with complexity*

$$(k'(k - k') + 1)s \sum_{j \leq k'} 4^j \binom{s}{j} d^{O(k)} = s^{k'+1} d^{O(k)}$$

*in  $D$ .*

Notice that the combinatorial complexity (i.e. the part that depends on  $s$ ) of the algorithm in Theorem 2.15 depends on the dimension of the variety rather than that of the ambient space.

**2.3. Certain quantitative results in metric semi-algebraic geometry.** In the case  $D = \mathbb{Z}$ , a careful analysis of the algorithm in Theorem 2.15 produces an explicit upper bound on the radius of a ball centered at the origin which is guaranteed to meet every semi-algebraically connected component of any  $\mathcal{P}$ -semi-algebraic set in terms of  $s, d, k$  and a bound on the bit-size,  $\tau$ , of the coefficients of  $\mathcal{P}$ . This and related bounds of this type are often needed in designing other algorithms (for instance, in order to compute certificates of positivity by sub-division method as done in [32]). The following rather technical but completely explicit estimate appears in [20] (the same paper contains several other explicit estimates of similar types).

**NOTATION 3.** Given an integer  $n$ , we denote by  $\text{bit}(n)$  the number of bits of its absolute value in the binary representation. Note that

$$(2.5) \quad \text{bit}(nm) \leq \text{bit}(n) + \text{bit}(m),$$

$$(2.6) \quad \text{bit} \left( \sum_{i=1}^n m_i \right) \leq \text{bit}(n) + \sup_{i=1}^n \text{bit}(m_i).$$



**Theorem 2.16.** [20] *Let  $\mathcal{P} = \{P_1, \dots, P_s\} \subset \mathbb{Z}[X_1, \dots, X_k]$  and suppose that  $P \in \mathcal{P}$  have degrees at most  $d$ , and the coefficients of  $P \in \mathcal{P}$  have bitsizes at most  $\tau$ . Then there exists a ball centered at the origin of radius*

$$\left( (2DN(2N-1) + 1) 2^{(2N-1)(\tau'' + \text{bit}(2N-1) + \text{bit}(2DN+1))} \right)^{1/2}$$

where

$$\begin{aligned} d' &= \sup(2(d+1), 6), \\ D &= k(d'-2) + 2, \\ N &= d'(d'-1)^{k-1}, \\ \tau'' &= N(\tau'_2 + \text{bit}(N) + 2\text{bit}(2D+1) + 1), \\ \tau'_2 &= \tau'_1 + 2(k-1)\text{bit}(N) + (2k-1)\text{bit}(k), \\ \tau'_1 &= D(\tau'_0 + 4\text{bit}(2D+1) + \text{bit}(N)) - 2\text{bit}(2D+1) - \text{bit}(N), \\ \tau'_0 &= 2\tau + k\text{bit}(d+1) + \text{bit}(2d') + \text{bit}(s) \end{aligned}$$

intersecting every semi-algebraically connected component of the realization of every realizable sign condition (resp. realizable weak sign condition) on  $\mathcal{P}$ .

*Remark 2.17.* Note that asymptotic bounds of the form  $2^{\tau d^{O(k)}}$  for the same problem were known before [19, 46, 67]. One point which needs some explanation is the fact that  $s$  plays a role in the estimate in Theorem 2.16, while it does not appear in the formula  $2^{\tau d^{O(k)}}$ . This is because the total number of polynomials of degree at most  $d$  in  $k$  variables with bitsizes bounded by  $\tau$  is bounded by  $(2^{\tau+1})^{\binom{d+k}{k}} = 2^{\tau d^{O(k)}}$ .

**2.4. Singly exponential quantifier elimination algorithms.** The algorithm with singly exponential algorithm for computing sample points in every semi-algebraically connected component of every realizable sign condition of a family of polynomials used in a parametrized way is a very important ingredient in designing algorithms with singly exponential complexity for real quantifier elimination. More precisely, it allows us to eliminate one whole block of variables (quantified by the same quantifier) at one time, unlike in algorithms based on cylindrical algebraic decomposition, where the elimination has to proceed one variable at a time *regardless of the block structure of the quantifiers*. The singly exponential algorithm for eliminating one block of variables at a time is formalized as the **Block Elimination Algorithm** [17, Chapter 14] and does the following. Given a finite family of polynomials  $\mathcal{P} \subset \mathbb{R}[X_1, \dots, X_k, Y_1, \dots, Y_\ell]$ , the Block Elimination Algorithm produces as output a family of polynomials  $\text{BElim}_X(\mathcal{P}) \subset \mathbb{R}[Y_1, \dots, Y_\ell]$ . The family  $\text{BElim}_X(\mathcal{P})$  has the following important property that justifies its name. For each semi-algebraically connected component,  $C \subset \mathbb{R}^\ell$ , of each realizable sign condition of  $\text{BElim}_X(\mathcal{P})$ , the set of realizable sign conditions of  $\mathcal{P}(y) \subset \mathbb{R}[X_1, \dots, X_k]$  stay invariant as  $y$  is allowed to vary over  $C$ . The Block Elimination Algorithm also produces a set of parametrized (by  $y$ ) sample points which are guaranteed to meet each semi-algebraically connected component of the set of realizable sign conditions of  $\mathcal{P}(y) \subset \mathbb{R}[X_1, \dots, X_k]$ . The complexity of this algorithm is bounded by  $s^{k+1} d^{O(\ell+k)}$ , where as usual  $s = \text{card } \mathcal{P}$  and  $d$  is a bound on the degrees of the polynomials in  $\mathcal{P}$ .

**2.4.1. Sign Determination Algorithm.** The *Block Elimination Algorithm* is one important ingredient of the critical point based quantifier elimination algorithm. The

other important ingredient is a *Sign Determination Algorithm* that allows one to compute the vector of signs of a family,  $\mathcal{P}$ , of  $s$  polynomials in  $D[X]$  at the real roots of a fixed polynomial  $Q \in D[X]$ , with complexity  $sd^{O(1)}$ , where  $d$  is a bound on the degrees of the polynomials in  $\mathcal{P}$  and  $Q$ . This algorithm was first discovered by Ben-Or, Kozen and Reif [26] and extended by Roy and Szpirglas [69] (see also [60] for recent improvements). This algorithm has also been generalized to the multi-variate case (where the zeros of  $Q$  could be positive dimensional), and this is described below in Section 3.3.

2.4.2. *Quantifier Elimination Algorithm.* The above ingredients (namely, the *Block Elimination Algorithm* and the *Sign Determination Algorithm*), along with numerous technical detail which we omit in this survey, allows one to prove the following result.

**Theorem 2.18.** [17] *Let  $\mathcal{P}$  be a set of at most  $s$  polynomials each of degree at most  $d$  in  $k + \ell$  variables with coefficients in a real closed field  $\mathbb{R}$ , and let  $\Pi$  denote a partition of the list of variables  $(X_1, \dots, X_k)$  into blocks,  $X_{[1]}, \dots, X_{[\omega]}$ , where the block  $X_{[i]}$  has size  $k_i, 1 \leq i \leq \omega$ . Given  $\Phi(Y)$ , a  $(\mathcal{P}, \Pi)$ -formula, there exists an equivalent quantifier free formula,*

$$\Psi(Y) = \bigvee_{i=1}^I \bigwedge_{j=1}^{J_i} \left( \bigvee_{n=1}^{N_{i,j}} \text{sign}(P_{ijn}(Y)) = \sigma_{ijn} \right),$$

where  $P_{ijn}(Y)$  are polynomials in the variables  $Y$ ,  $\sigma_{ijn} \in \{0, 1, -1\}$ ,

$$I \leq s^{(k_\omega+1)\cdots(k_1+1)(\ell+1)} d^{O(k_\omega)\cdots O(k_1)O(\ell)},$$

$$J_i \leq s^{(k_\omega+1)\cdots(k_1+1)} d^{O(k_\omega)\cdots O(k_1)},$$

$$N_{ij} \leq d^{O(k_\omega)\cdots O(k_1)},$$

and the degrees of the polynomials  $P_{ijk}(y)$  are bounded by  $d^{O(k_\omega)\cdots O(k_1)}$ . Moreover, there is an algorithm to compute  $\Psi(Y)$  with complexity

$$s^{(k_\omega+1)\cdots(k_1+1)(\ell+1)} d^{O(k_\omega)\cdots O(k_1)O(\ell)}$$

in  $\mathbb{D}$ , denoting by  $\mathbb{D}$  the ring generated by the coefficients of  $\mathcal{P}$ .

If  $\mathbb{D} = \mathbb{Z}$ , and the bit-sizes of the coefficients of the polynomials are bounded by  $\tau$ , then the bit-sizes of the integers appearing in the intermediate computations and the output are bounded by  $\tau d^{O(k_\omega)\cdots O(k_1)O(\ell)}$ .

*Remark 2.19.* The algorithmic results described in Section 2.2 are based on one common technique – namely, by taking a well chosen infinitesimal perturbation, one can replace any bounded, real (possibly singular) variety  $V \subset \mathbb{R}^k$ , by a non-singular variety defined over an (non-archimedean) extension of  $\mathbb{R}$ , and the projection map on some co-ordinate (say  $X_1$ ) restricted to this variety has non-degenerate critical points, which moreover are defined by a zero-dimensional system of equations which is nicely behaved (is automatically a Gröbner basis). The limits of these critical points belong to the given variety  $V$  and moreover they meet every semi-algebraically connected component of  $V$ . This technique (which is rather special to real algebraic geometry as opposed to complex geometry) has several advantages from the point of view of algorithmic complexity. The first advantage is that it is not necessary to choose any generic co-ordinate system or direction to project on. Secondly, the method does not care about how singular the given variety  $V$  is

or even its dimension. Moreover, it is possible to relate the topology (up to semi-algebraic homotopy equivalence) of  $V$  with the infinitesimal “tube” around it which is bounded by the perturbed hyper-surface (say  $V'$ ). This reduces most algorithmic problems of computing topological invariants of  $V$ , to that of the well-behaved hyper-surface  $V'$ . Since the degree of the polynomial defining  $V'$  is at most twice that of the one defining  $V$ , and the computations take place in the original ring adjoined with at most a constant many (i.e. their number is independent of the input parameters  $s, d$  and  $k$ ) infinitesimals, the complexity is well controlled. The main disadvantage of the approach (which could a drawback from the point of view of practical implementation point) is that computations with even a constant many infinitesimals are quite expensive (even though they do not affect the asymptotic complexity bounds). Also, the process of taking algebraic limits at the end can be quite cumbersome. Nevertheless, this perturbation approach remains the only one which gives deterministic algorithms with the best known worst case complexity estimates.

**2.5. Intrinsic complexity and complex algebraic techniques.** The model for studying complexity of algorithms in this survey is that the size of the input is measured in terms of the number of coefficients needed to specify the input polynomials in the dense representation. Since this number is determined by the following parameters:

- (1) the number of variables,  $k$ ;
- (2) the number of polynomials,  $s$ ;
- (3) the degrees of the polynomials,  $d$ ;

it makes sense to state the complexity estimates in terms of  $s, d$  and  $k$ .

There is another body of work (see for example [1, 2, 70, 71, 49]) in which the goal is to obtain algorithms for computing sample points on each semi-algebraically connected component of a given real algebraic variety  $V \subset \mathbb{R}^k$ , whose complexity is bounded by a *polynomial* function of some *intrinsic* invariant of the variety  $V$  or in some cases the length of *straight line programs* encoding the input polynomials. In this approach, the real variety  $V$  is considered as the real part of the complex variety  $V_{\mathbb{C}} \subset \mathbb{C}^k$  (where  $\mathbb{C}$  is the algebraic closure of  $\mathbb{R}$ ), and the intrinsic invariant,  $\delta(V) = \delta(V_{\mathbb{C}})$  depends only on the geometry of the complex variety  $V_{\mathbb{C}}$ , and not on the particular presentation of it by the given input polynomials. If  $d$  is a bound on the degrees of the polynomials defining  $V$ , then  $\delta(V)$  is bounded by  $O(d)^k$  and could be as large as  $d^k$  in the worst case. However,  $\delta(V)$  could be smaller in special cases.

Since these algorithms aim at complexity in terms of some geometric invariant of the variety itself, the infinitesimal perturbation techniques described in the previous sections is not available, since such a perturbation will not in general preserve this invariant. Hence, one needs to work directly with the given variety. For example, one needs to prove that under certain assumptions on the variety, the critical points of a generic projection (also called the polar variety) is non-singular (see [3]). The theory of *geometric resolutions* (see [2]) play an important role in these algorithms.

One feature of the algorithms that follow from these techniques is that it is necessary to choose generic co-ordinates which cannot be done deterministically within the claimed complexity bounds. As such one obtains *probabilistic* (as opposed to deterministic) algorithms, meaning that these algorithms always run within the

stated complexity time bounds, but is guaranteed to give correct results only with high probability.

**2.6. Variants of quantifier elimination and applications.** In certain applications (most notably in the theory of constraint databases) one needs to perform quantifier elimination in a more generalized setting than that discussed above. For instance, it is sometimes necessary to eliminate quantifiers not just from one formula, but a whole sequence of formulas described in some finite terms, where the number of free variables is allowed to grow in the sequence. Clearly, the quantifier elimination algorithms described previously is not sufficient for this purpose since their complexity depends on the number of free variables.

We describe below a variant of the quantifier elimination problem which was introduced in [6] motivated by a problem in constraint databases.

2.6.1. *The Uniform Quantifier Elimination Problem.*

**Definition 2.20.** We call a sequence,

$$\{\phi_n(T_1, \dots, T_\ell, Y_1, \dots, Y_n) \mid n > 0\}$$

of first-order formulas  $\phi_n$  in the language of ordered fields, to be a **uniform sequence** if each  $\phi_n$  has the form,

$$\begin{aligned} \phi_n(T_1, \dots, T_\ell, Y_1, \dots, Y_n) = \\ Q_{1 \leq k_1 \leq n}^1 \cdots Q_{1 \leq k_\omega \leq n}^\omega \phi(T_1, \dots, T_\ell, Y_{k_1}, \dots, Y_{k_\omega}), \end{aligned}$$

where  $Q^i \in \{\forall, \wedge\}$ ,  $1 \leq i \leq \omega$  and  $\phi$  is some fixed  $(\ell + \omega)$ -ary quantifier-free first-order formula.

Thus for every  $n$ ,  $\phi_n$  is a first order formula with  $\ell + n$  free variables. We will refer to the variables  $T_1, \dots, T_\ell$  as *parameters*.

Given a uniform sequence of formulas  $\Phi = \{\phi_n \mid n > 0\}$ , where

$$\begin{aligned} \phi_n(T_1, \dots, T_\ell, Y_1, \dots, Y_n) = \\ Q_{1 \leq k_1 \leq n}^1 \cdots Q_{1 \leq k_\omega \leq n}^\omega \phi(T_1, \dots, T_\ell, Y_{k_1}, \dots, Y_{k_\omega}), \end{aligned}$$

we define the *size* of  $\Phi$  to be the length of the formula  $\phi$ .

**Example 2.21.** Consider the uniform sequence of formulas

$$\phi_n(T_1, Y_1, \dots, Y_n) = \bigwedge_{1 \leq k_1 \leq n} (Y_{k_1} - T_1 = 0), \quad n > 0.$$

Consider the sequence of quantified formulas,  $(\exists T_1)\phi_n(T_1, Y_1, \dots, Y_n)$ . In this example, it is easily seen that letting

$$\Psi_n = \bigwedge_{1 \leq k_1 \leq n} \bigwedge_{1 \leq k_2 \leq n} (Y_{k_1} - Y_{k_2} = 0),$$

we get a uniform sequence of quantifier-free formulas satisfying,

$$\Psi_n(Y_1, \dots, Y_n) \Leftrightarrow (\exists T_1)\phi_n(T_1, Y_1, \dots, Y_n)$$

for every  $n > 0$ .

The **uniform quantifier elimination problem** is to eliminate quantifiers from a uniform sequence of formulas and obtain another *uniform* sequence of quantifier free formulas.

The following is proved in [6].

**Theorem 2.22.** (*Uniform Quantifier Elimination*) *Let,*

$$\Phi = \{\phi_n(T_1, \dots, T_\ell, Y_1, \dots, Y_n) \mid n > 0\}$$

*be a uniform sequence of formulas with parameters  $T_1, \dots, T_\ell$ , where*

$$\begin{aligned} \phi_n(T_1, \dots, T_\ell, Y_1, \dots, Y_n) = \\ Q_{1 \leq k_1 \leq n}^1 \cdots Q_{1 \leq k_\omega \leq n}^\omega \phi(T_1, \dots, T_\ell, Y_{k_1}, \dots, Y_{k_\omega}). \end{aligned}$$

*Let the number of different  $(\ell + \omega)$ -variate polynomials appearing in  $\phi$  be  $s$  and let their degrees be bounded by  $d$ .*

*Let  $R_1, \dots, R_m \in \{\exists, \forall\}$ ,  $R_i \neq R_{i+1}$ , and let  $T^{[1]}, \dots, T^{[m]}$  be a partition of the variables,  $T_1, \dots, T_\ell$  into  $m$  blocks of size  $\ell_1, \dots, \ell_m$ , where  $\sum_{1 \leq i \leq m} \ell_i = \ell$ .*

*Then, there exists an algorithm that outputs a quantifier-free first order formula,  $\psi(Y_{k_1}, \dots, Y_{k_{\omega'}})$ , along with  $Q^i \in \{\forall, \exists\}$ ,  $1 \leq i \leq \omega'$ , such that for every  $n > 0$*

$$\begin{aligned} \psi_n(Y_1, \dots, Y_n) = Q_{1 \leq k_1 \leq n}^1 \cdots Q_{1 \leq k_{\omega'} \leq n}^{\omega'} \psi(Y_{k_1}, \dots, Y_{k_{\omega'}}) \\ \Leftrightarrow (R_1 T^{[1]}) \cdots (R_m T^{[m]}) \phi_n(Y_1, \dots, Y_n, T_1, \dots, T_\ell). \end{aligned}$$

*The complexity of the algorithm is bounded by*

$$s^{\prod_i (\ell_i + 1)} d^\omega \prod_i O(\ell_i^2),$$

*and the size of the formula  $\psi$  is bounded by*

$$s^{\prod_i (\ell_i + 1)} d^\omega \prod_i O(\ell_i^2) \text{size}(\phi).$$

*Remark 2.23.* In [6] Theorem 2.22 is used to prove the equivalence of two different semantics and in the theory of constraint databases. However, it also has applications in logic. For example, in the same paper it is used to prove that semi-algebraic connectivity is not expressible by a first-order formula (see [6] for a precise definition of first-order expressibility). This inexpressibility result has as a consequence that we cannot hope to use quantifier-elimination directly to check whether a given semi-algebraic set is semi-algebraically connected (unlike other first-order expressible topological properties such as being open or closed etc. where it is possible to do so). Note that the inexpressibility result was also proved by more abstract model theoretic methods in [27].

The technique used in the proof of Theorem 2.22 is also used in [6] to give an algorithm for ordinary quantifier elimination whose complexity depends on the size of the input formula, and which has better complexity than the algorithm in Theorem 2.18 in case the input formula has a small size. This algorithm is called **Local Quantifier Elimination Algorithm** in [17].

### 3. COMPUTING TOPOLOGICAL INVARIANTS OF SEMI-ALGEBRAIC SETS

As remarked above (see Remark 2.23), an effective algorithm for deciding connectivity of semi-algebraic sets does not automatically follow from the Tarski-Seidenberg principle. However, one can decide questions about connectivity (as well as compute other topological invariants such as the Betti numbers) using effective triangulation of semi-algebraic sets via Cylindrical Algebraic Decomposition. However, such an algorithm will necessarily have doubly exponential complexity.

Most of the recent work in algorithmic semi-algebraic geometry has focused on obtaining *singly exponential time* algorithms – that is algorithms with complexity

of the order of  $(sd)^{k^{O(1)}}$  rather than  $(sd)^{2^k}$ . An important motivating reason behind the search for such algorithms, is the following theorem due to Gabrielov and Vorobjov [43] (see also [42]) (see [61, 75, 55, 7], as well as the survey article [15], for work leading up to this result) which gives singly exponential upper bound on the topological complexity of semi-algebraic sets measured by the sum of their Betti numbers.

**Theorem 3.1.** [43] *For a  $\mathcal{P}$ -semi-algebraic set  $S \subset \mathbb{R}^k$ , the sum of the Betti numbers of  $S$  is bounded by  $(O(skd))^k$ , where  $s = \text{card } \mathcal{P}$ , and  $d = \max_{P \in \mathcal{P}} \deg(P)$ .*

For the special case of  $\mathcal{P}$ -closed semi-algebraic sets the following slightly better bound was known before [7] (and this bound is used in an essential way in the proof of Theorem 3.1). Using the same notation as in Theorem 3.1 above we have

**Theorem 3.2.** [7] *For a  $\mathcal{P}$ -closed semi-algebraic set  $S \subset \mathbb{R}^k$ , the sum of the Betti numbers of  $S$  is bounded by  $(O(sd))^k$ .*

*Remark 3.3.* These bounds are asymptotically tight, as can be already seen from the example where each  $P \in \mathcal{P}$  is a product of  $d$  generic polynomials of degree one. The number of semi-algebraically connected components of the  $\mathcal{P}$ -semi-algebraic set defined as the subset of  $\mathbb{R}^k$  where all polynomials in  $\mathcal{P}$  are non-zero is clearly bounded from below by  $(Csd)^k$  for some constant  $C$ .

**3.1. Roadmaps.** Theorem 2.15 gives a singly exponential time algorithm for testing if a given semi-algebraic set is empty or not. However, it gives no way of testing if any two sample points computed by it belong to the same semi-algebraically connected component of the given semi-algebraic set, even though the set of sample points is guaranteed to meet each such semi-algebraically connected component. In order to obtain connectivity information in singly exponential time a more sophisticated construction is required – namely that of a *roadmap* of a semi-algebraic set, which is an one dimensional semi-algebraic subset of the given semi-algebraic set which is non-empty and semi-algebraically connected inside each semi-algebraically connected component of the given set. Roadmaps were first introduced by Canny [33], but similar constructions were considered as well by Grigoriev and Vorobjov [45] and Gournay and Risler [44]. Our exposition below follows that in [14, 17] where the most efficient algorithm for computing roadmaps is given. The notions of pseudo-critical points and values defined above play a critical role in the design of efficient algorithms for computing roadmaps of semi-algebraic sets.

We first define a *roadmap of a semi-algebraic set*. We use the following notation. We denote by  $\pi_{1\dots j}$  the projection,  $x \mapsto (x_1, \dots, x_j)$ . Given a set  $S \subset \mathbb{R}^k$  and  $y \in \mathbb{R}^j$ , we denote by  $S_y = S \cap \pi_{1\dots j}^{-1}(y)$ .

**Definition 3.4** (Roadmap of a semi-algebraic set). Let  $S \subset \mathbb{R}^k$  be a semi-algebraic set. A *roadmap* for  $S$  is a semi-algebraic set  $M$  of dimension at most one contained in  $S$  which satisfies the following roadmap conditions:

- $\text{RM}_1$  For every semi-algebraically connected component  $D$  of  $S$ ,  $D \cap M$  is non-empty and semi-algebraically connected.
- $\text{RM}_2$  For every  $x \in \mathbb{R}$  and for every semi-algebraically connected component  $D'$  of  $S_x$ ,  $D' \cap M \neq \emptyset$ .

We describe the construction of a roadmap  $\text{RM}(Z(Q, \mathbb{R}^k), \mathcal{N})$  for a bounded algebraic set  $Z(Q, \mathbb{R}^k)$  which contains a finite set of points  $\mathcal{N}$  of  $Z(Q, \mathbb{R}^k)$ . A

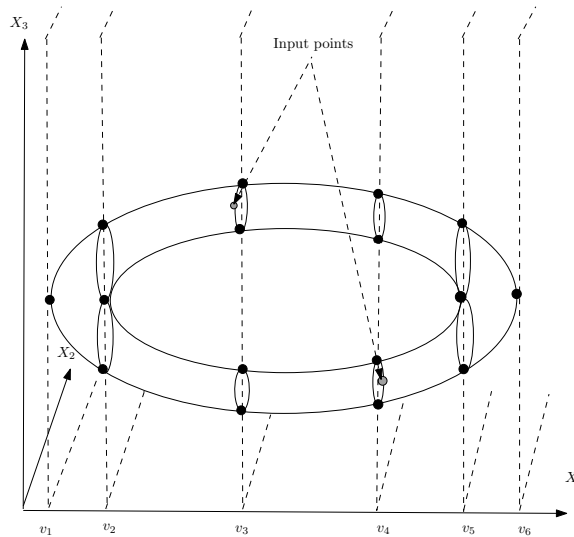

FIGURE 3. Roadmap of the torus in  $\mathbb{R}^3$ .

precise description of how the construction can be performed algorithmically can be found in [17]. We should emphasize here that  $\text{RM}(Z(Q, \mathbb{R}^k), \mathcal{N})$  denotes the semi-algebraic set output by the specific algorithm described below which satisfies the properties stated in Definition 3.4 (cf. Proposition 3.5).

Also, in order to understand the roadmap algorithm it is easier to first concentrate on the case of a bounded and non-singular real algebraic set in  $\mathbb{R}^k$  (see Figure 3 below). In this case several definitions get simplified. For example, the pseudo-critical values defined below are in this case ordinary critical values of the projection map on the first co-ordinate. However, one should keep in mind that even if one starts with a bounded non-singular algebraic set, the input to the recursive calls corresponding to the critical sections (see below) are necessarily singular and thus it is not possible to treat the non-singular case independently.

A key ingredient of the roadmap is the construction of pseudo-critical points and values defined above. The construction of the roadmap of an algebraic set containing a finite number of input points  $\mathcal{N}$  of this algebraic set is as follows. We first construct  $X_2$ -pseudo-critical points on  $Z(Q, \mathbb{R}^k)$  in a parametric way along the  $X_1$ -axis by following continuously, as  $x$  varies on the  $X_1$ -axis, the  $X_2$ -pseudo-critical points on  $Z(Q, \mathbb{R}^k)_x$ . This results in curve segments and their endpoints on  $Z(Q, \mathbb{R}^k)$ . The curve segments are continuous semi-algebraic curves parametrized by open intervals on the  $X_1$ -axis and their endpoints are points of  $Z(Q, \mathbb{R}^k)$  above the corresponding endpoints of the open intervals. Since these curves and their endpoints include for every  $x \in \mathbb{R}$  the  $X_2$ -pseudo-critical points of  $Z(Q, \mathbb{R}^k)_x$ , they meet every semi-algebraically connected component of  $Z(Q, \mathbb{R}^k)_x$ . Thus, the set of curve segments and their endpoints already satisfy  $\text{RM}_2$ . However, it is clear that this set might not be semi-algebraically connected in a semi-algebraically connected component and so  $\text{RM}_1$  might not be satisfied. We add additional curve segments

to ensure connectedness by recursing in certain distinguished hyper-planes defined by  $X_1 = z$  for distinguished values  $z$ .

The set of *distinguished values* is the union of the  $X_1$ -pseudo-critical values, the first coordinates of the input points  $\mathcal{N}$ , and the first coordinates of the endpoints of the curve segments. A *distinguished hyper-plane* is an hyper-plane defined by  $X_1 = v$ , where  $v$  is a distinguished value. The input points, the endpoints of the curve segments, and the intersections of the curve segments with the distinguished hyper-planes define the set of *distinguished points*.

Let the distinguished values be  $v_1 < \dots < v_\ell$ . Note that amongst these are the  $X_1$ -pseudo-critical values. Above each interval  $(v_i, v_{i+1})$  we have constructed a collection of curve segments  $\mathcal{C}_i$  meeting every semi-algebraically connected component of  $Z(Q, \mathbb{R}^k)_v$  for every  $v \in (v_i, v_{i+1})$ . Above each distinguished value  $v_i$  we have a set of distinguished points  $\mathcal{N}_i$ . Each curve segment in  $\mathcal{C}_i$  has an endpoint in  $\mathcal{N}_i$  and another in  $\mathcal{N}_{i+1}$ . Moreover, the union of the  $\mathcal{N}_i$  contains  $\mathcal{N}$ .

We then repeat this construction in each distinguished hyper-plane  $H_i$  defined by  $X_1 = v_i$  with input  $Q(v_i, X_2, \dots, X_k)$  and the distinguished points in  $\mathcal{N}_i$ . Thus, we construct distinguished values  $v_{i,1}, \dots, v_{i,\ell(i)}$  of  $Z(Q(v_i, X_2, \dots, X_k), \mathbb{R}^{k-1})$  (with the role of  $X_1$  being now played by  $X_2$ ) and the process is iterated until for  $I = (i_1, \dots, i_{k-2}), 1 \leq i_1 \leq \ell, \dots, 1 \leq i_{k-2} \leq \ell(i_1, \dots, i_{k-3})$ , we have distinguished values  $v_{I,1} < \dots < v_{I,\ell(I)}$  along the  $X_{k-1}$  axis with corresponding sets of curve segments and sets of distinguished points with the required incidences between them.

The following theorem is proved in [14] (see also [17]).

**Proposition 3.5.** *The semi-algebraic set  $\text{RM}(Z(Q, \mathbb{R}^k), \mathcal{N})$  obtained by this construction is a roadmap for  $Z(Q, \mathbb{R}^k)$  containing  $\mathcal{N}$ .*

Note that if  $x \in Z(Q, \mathbb{R}^k)$ ,  $\text{RM}(Z(Q, \mathbb{R}^k), \{x\})$  contains a path,  $\gamma(x)$ , connecting a distinguished point  $p$  of  $\text{RM}(Z(Q, \mathbb{R}^k))$  to  $x$ .

3.1.1. *Roadmaps of general semi-algebraic sets.* Using the same ideas as above and some additional techniques for controlling the combinatorial complexity of the algorithm it is possible to extend the roadmap algorithm to the case of semi-algebraic sets. The following theorem appears in [14, 17].

**Theorem 3.6.** [14, 17] *Let  $Q \in \mathbb{R}[X_1, \dots, X_k]$  with  $Z(Q, \mathbb{R}^k)$  of dimension  $k'$  and let  $\mathcal{P} \subset \mathbb{R}[X_1, \dots, X_k]$  be a set of at most  $s$  polynomials for which the degrees of the polynomials in  $\mathcal{P}$  and  $Q$  are bounded by  $d$ . Let  $S$  be a  $\mathcal{P}$ -semi-algebraic subset of  $Z(Q, \mathbb{R}^k)$ . There is an algorithm which computes a roadmap  $\text{RM}(S)$  for  $S$  with complexity  $s^{k'+1}d^{O(k^2)}$  in the ring  $\mathbb{D}$  generated by the coefficients of  $Q$  and the elements of  $\mathcal{P}$ . If  $\mathbb{D} = \mathbb{Z}$ , and the bit-sizes of the coefficients of the polynomials are bounded by  $\tau$ , then the bit-sizes of the integers appearing in the intermediate computations and the output are bounded by  $\tau d^{O(k^2)}$ .*

Theorem 3.6 immediately implies that there is an algorithm whose output is exactly one point in every semi-algebraically connected component of  $S$  and whose complexity in the ring generated by the coefficients of  $Q$  and  $\mathcal{P}$  is bounded by  $s^{k'+1}d^{O(k^2)}$ . In particular, this algorithm counts the number semi-algebraically connected component of  $S$  within the same time bound.



3.1.2. *Recent developments.* Very recently Schost and Safey el Din [41] have given a *probabilistic* algorithm for computing the roadmap of a smooth, bounded real algebraic hyper-surface in  $\mathbb{R}^k$  defined by a polynomial of degree  $d$ , whose complexity is bounded by  $d^{\mathcal{O}(k^{3/2})}$ . Complex algebraic techniques related to the geometry of polar varieties play an important role in this algorithm. More recently, a *deterministic* algorithm for computing roadmaps of *arbitrary* real algebraic sets with the same complexity bound, has also been obtained [21]. This algorithm is based on techniques coming from semi-algebraic geometry and can be seen as a direct generalization of Proposition 3.5 above. The main new idea is to consider the critical points of projection maps onto a co-ordinate subspace of dimension bigger than 1 (in fact, of dimension  $\sqrt{k}$ ). As a result the dimensions in the recursive calls to the algorithm decreases by  $\sqrt{k}$  at each step of the recursion (compared to the case of the ordinary roadmap algorithms where it decreases by 1 in each step). This results in the improved complexity. One also needs to prove suitable generalizations of the results guaranteeing the connectivity of the roadmap (see [17, Chapter 15]) in this more general situation.

3.1.3. *Parametrized paths.* One important idea in the algorithm for computing the first Betti number of semi-algebraic sets, is the construction of certain semi-algebraic sets called *parametrized paths*. Under a certain hypothesis, these sets are semi-algebraically contractible. Moreover, there exists an algorithm for computing a covering of a given basic semi-algebraic set,  $S \subset \mathbb{R}^k$ , by a singly exponential number of parametrized paths.

*Parametrized Paths.* We are given a polynomial  $Q \in \mathbb{R}[X_1, \dots, X_k]$  such that  $Z(Q, \mathbb{R}^k)$  is bounded and a finite set of polynomials  $\mathcal{P} \subset \mathbb{R}[X_1, \dots, X_k]$ .

The main technical construction underlying the algorithm for computing the first Betti number in [18], is to obtain a covering of a given  $\mathcal{P}$ -closed semi-algebraic set contained in  $Z(Q, \mathbb{R}^k)$  by a family of semi-algebraically contractible subsets. This construction is based on a parametrized version of the connecting algorithm: we compute a family of polynomials such that for each realizable sign condition  $\sigma$  on this family, the description of the connecting paths of different points in the realization,  $\mathcal{R}(\sigma, Z(Q, \mathbb{R}^k))$ , are uniform. We first define parametrized paths. A parametrized path is a semi-algebraic set which is a union of semi-algebraic paths having a special property called the *divergence property* in [18].

More precisely,

**Definition 3.7** (Parametrized paths). A *parametrized path*  $\gamma$  is a continuous semi-algebraic mapping from  $V \subset \mathbb{R}^{k+1} \rightarrow \mathbb{R}^k$ , such that, denoting by  $U = \pi_{1\dots k}(V) \subset \mathbb{R}^k$ , there exists a semi-algebraic continuous function  $\ell : U \rightarrow [0, +\infty)$ , and there exists a point  $a$  in  $\mathbb{R}^k$ , such that

- (1)  $V = \{(x, t) \mid x \in U, 0 \leq t \leq \ell(x)\}$ ,
- (2)  $\forall x \in U, \gamma(x, 0) = a$ ,
- (3)  $\forall x \in U, \gamma(x, \ell(x)) = x$ ,
- (4)

$$\forall x \in U, \forall y \in U, \forall s \in [0, \ell(x)], \forall t \in [0, \ell(y)]$$

$$(\gamma(x, s) = \gamma(y, t) \Rightarrow s = t),$$

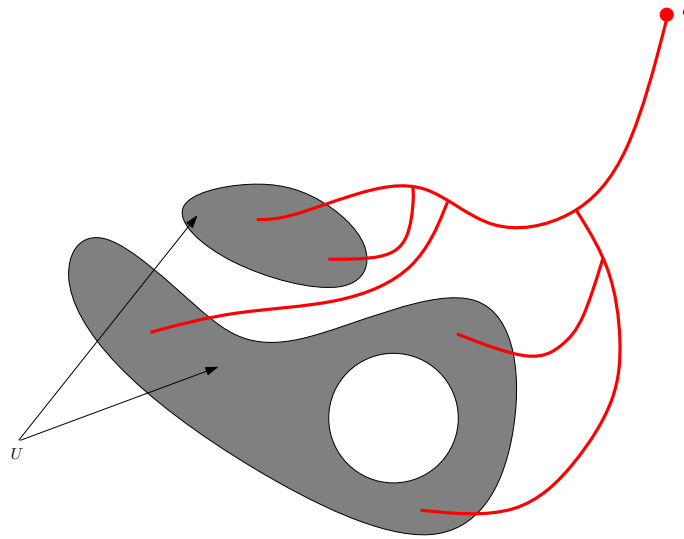

FIGURE 4. A parametrized path

(5)

$$\forall x \in U, \forall y \in U, \forall s \in [0, \min(\ell(x), \ell(y))] \\ (\gamma(x, s) = \gamma(y, s) \Rightarrow \forall t \leq s \gamma(x, t) = \gamma(y, t)).$$

Given a parametrized path,  $\gamma : V \rightarrow \mathbb{R}^k$ , we will refer to  $U = \pi_{1\dots k}(V)$  as its *base*. Also, any semi-algebraic subset  $U' \subset U$  of the base of such a parametrized path, defines in a natural way the restriction of  $\gamma$  to the base  $U'$ , which is another parametrized path, obtained by restricting  $\gamma$  to the set  $V' \subset V$ , defined by  $V' = \{(x, t) \mid x \in U', 0 \leq t \leq \ell(x)\}$ .

The following proposition which appears in [18] describes a crucial property of parametrized paths, which makes them useful in algorithms for computing Betti numbers of semi-algebraic sets.

**Proposition 3.8.** [18] *Let  $\gamma : V \rightarrow \mathbb{R}^k$  be a parametrized path such that  $U = \pi_{1\dots k}(V)$  is closed and bounded. Then, the image of  $\gamma$  is semi-algebraically contractible.*

For every point  $x$  of  $Z(Q, \mathbb{R}^k)$ , denote by  $\sigma(x)$  the sign condition on  $\mathcal{P}$  at  $x$ . Let  $\mathcal{R}(\bar{\sigma}(x), Z(Q, \mathbb{R}^k)) = \{x \in Z(Q, \mathbb{R}^k) \mid \bigwedge_{P \in \mathcal{P}} \text{sign}(P(x)) \in \bar{\sigma}(x)(P)\}$ , where  $\bar{\sigma}$  is the relaxation of  $\sigma$  defined by

$$\begin{cases} \bar{\sigma} = \{0\} & \text{if } \sigma = 0, \\ \bar{\sigma} = \{0, 1\} & \text{if } \sigma = 1, \\ \bar{\sigma} = \{0, -1\} & \text{if } \sigma = -1. \end{cases}$$

We say that  $\bar{\sigma}(x)$  is the *weak sign condition* defined by  $x$  on  $\mathcal{P}$ . We denote by  $\mathcal{P}(x)$  the union of  $\{Q\}$  and the set of polynomials in  $\mathcal{P}$  vanishing at  $x$ .

The following theorem appears in [18].

**Theorem 3.9.** *There exists an algorithm that takes as input a finite set of polynomials  $\mathcal{P} \subset \mathbb{R}[X_1, \dots, X_k]$ , and produces as output,*

- a finite set of polynomials  $\mathcal{A} \subset \mathbb{R}[X_1, \dots, X_k]$ ,
- a finite set  $\Theta$  of quantifier free formulas, with atoms of the form  $P = 0, P > 0, P < 0, P \in \mathcal{A}$ , such that for every semi-algebraically connected component  $S$  of the realization of every weak sign condition on  $\mathcal{P}$  on  $Z(Q, \mathbb{R}^k)$ , there exists a subset  $\Theta(S) \subset \Theta$  such that  $S = \bigcup_{\theta \in \Theta(S)} \mathcal{R}(\theta, Z(Q, \mathbb{R}^k))$ ,
- for every  $\theta \in \Theta$ , a parametrized path

$$\gamma_\theta : V_\theta \rightarrow \mathbb{R}^k,$$

with base  $U_\theta = \mathcal{R}(\theta, Z(Q, \mathbb{R}^k))$ , such that for each  $y \in \mathcal{R}(\theta, Z(Q, \mathbb{R}^k))$ ,  $\text{Im } \gamma_\theta(y, \cdot)$  is a semi-algebraic path which connects the point  $y$  to a distinguished point  $a_\theta$  of some roadmap  $\text{RM}(Z(\mathcal{P}' \cup \{Q\}, \mathbb{R}^k))$  where  $\mathcal{P}' \subset \mathcal{P}$ , staying inside  $\mathcal{R}(\theta, Z(Q, \mathbb{R}^k))$ .

Moreover, the complexity of the algorithm is  $s^{k'+1}d^{O(k^4)}$ , where  $s$  is a bound on the number of elements of  $\mathcal{P}$  and  $d$  is a bound on the degrees of  $Q$  and the elements of  $\mathcal{P}$ .

**3.2. Computing higher Betti numbers.** It clear that the Betti numbers of a semi-algebraic set which is closed and bounded can be computed using elementary linear algebra once we have a triangulation of the set. However, triangulations of semi-algebraic sets are expensive to compute, requiring doubly exponential time.

One basic idea that underlies some of the recent progress in designing algorithms for computing the Betti numbers of semi-algebraic sets is that the cohomology groups of a semi-algebraic set can often be computed from a sufficiently well-behaved covering of the set *without having to triangulate the set*.

The idea of computing cohomology from “good” covers is an old one in algebraic topology and the first result in this direction is often called the “Nerve Lemma”. In this section we give a brief introduction to the Nerve Lemma and its generalizations.

We first define formally the notion of a cover of a closed, bounded semi-algebraic set.

**Definition 3.10 (Cover).** Let  $S \subset \mathbb{R}^k$  be a closed and bounded semi-algebraic set. A cover,  $\mathcal{C}(S)$ , of  $S$  consists of an ordered index set, which by a slight abuse of language we also denote by  $\mathcal{C}(S)$ , and a map that associates to each  $\alpha \in \mathcal{C}(S)$  a closed and bounded semi-algebraic subset  $S_\alpha \subset S$  such that

$$S = \bigcup_{\alpha \in \mathcal{C}(S)} S_\alpha.$$

For  $\alpha_0, \dots, \alpha_p \in \mathcal{C}(S)$ , we associate to the formal product,  $\alpha_0 \cdots \alpha_p$ , the closed and bounded semi-algebraic set

$$(3.1) \quad S_{\alpha_0 \cdots \alpha_p} = S_{\alpha_0} \cap \cdots \cap S_{\alpha_p}.$$

Recall that the 0-th simplicial cohomology group of a closed and bounded semi-algebraic set  $X$ ,  $H^0(X)$ , can be identified with the  $\mathbb{Q}$ -vector space of  $\mathbb{Q}$ -valued locally constant functions on  $X$ . Clearly the dimension of  $H^0(X)$  is equal to the number of connected components of  $X$ .

For  $\alpha_0, \alpha_1, \dots, \alpha_p, \beta \in \mathcal{C}(S)$ , and  $\beta \notin \{\alpha_0, \dots, \alpha_p\}$ , let

$$r_{\alpha_0, \dots, \alpha_p; \beta} : H^0(S_{\alpha_0 \cdots \alpha_p}) \longrightarrow H^0(S_{\alpha_0 \cdots \alpha_p \cdot \beta})$$

be the homomorphism defined as follows. Given a locally constant function,  $\phi \in H^0(S_{\alpha_0 \cdots \alpha_p})$ ,  $r_{\alpha_0 \cdots \alpha_p; \beta}(\phi)$  is the locally constant function on  $S_{\alpha_0 \cdots \alpha_p, \beta}$  obtained by restricting  $\phi$  to  $S_{\alpha_0 \cdots \alpha_p, \beta}$ .

We define the generalized restriction homomorphisms

$$\delta^p : \bigoplus_{\alpha_0 < \cdots < \alpha_p, \alpha_i \in \mathcal{C}(S)} H^0(S_{\alpha_0 \cdots \alpha_p}) \longrightarrow \bigoplus_{\alpha_0 < \cdots < \alpha_{p+1}, \alpha_i \in \mathcal{C}(S)} H^0(S_{\alpha_0 \cdots \alpha_{p+1}})$$

by

$$(3.2) \quad \delta^p(\phi)_{\alpha_0 \cdots \alpha_{p+1}} = \sum_{0 \leq i \leq p+1} (-1)^i r_{\alpha_0 \cdots \hat{\alpha}_i \cdots \alpha_{p+1}; \alpha_i}(\phi_{\alpha_0 \cdots \hat{\alpha}_i \cdots \alpha_{p+1}}),$$

where  $\phi \in \bigoplus_{\alpha_0 < \cdots < \alpha_p \in \mathcal{C}(S)} H^0(S_{\alpha_0 \cdots \alpha_p})$  and  $r_{\alpha_0 \cdots \hat{\alpha}_i \cdots \alpha_{p+1}; \alpha_i}$  is the restriction homomorphism defined previously. The sequence of homomorphisms  $\delta^p$  gives rise to a complex,  $L^\bullet(\mathcal{C}(S))$ , defined by

$$(3.3) \quad L^p(\mathcal{C}(S)) = \bigoplus_{\alpha_0 < \cdots < \alpha_p, \alpha_i \in \mathcal{C}(S)} H^0(S_{\alpha_0 \cdots \alpha_p}),$$

with the differentials  $\delta^p : L^p(\mathcal{C}(S)) \rightarrow L^{p+1}(\mathcal{C}(S))$  defined as in Eqn. (3.2).

**Definition 3.11** (Nerve complex). The complex  $L^\bullet(\mathcal{C}(S))$  is called the *nerve complex* of the cover  $\mathcal{C}(S)$ .

For  $\ell \geq 0$  we will denote by  $L_\ell^\bullet(\mathcal{C}(S))$  the truncated complex defined by

$$\begin{aligned} L_\ell^p(\mathcal{C}(S)) &= L^p(\mathcal{C}(S)), \quad 0 \leq p \leq \ell, \\ &= 0, \quad p > \ell. \end{aligned}$$

Notice that once we have a cover of  $S$  and we identify the semi-algebraically connected components of the various intersections,  $S_{\alpha_0 \cdots \alpha_p}$ , we have natural bases for the vector spaces

$$L^p(\mathcal{C}(S)) = \bigoplus_{\alpha_0 < \cdots < \alpha_p, \alpha_i \in \mathcal{C}(S)} H^0(S_{\alpha_0 \cdots \alpha_p})$$

appearing as terms of the nerve complex. Moreover, the matrices corresponding to the homomorphisms  $\delta^p$  in this basis depend only on the inclusion relationships between the semi-algebraically connected components of  $S_{\alpha_0 \cdots \alpha_{p+1}}$  and those of  $S_{\alpha_0 \cdots \alpha_p}$ .

**Definition 3.12** (Leray Property). We say that the cover  $\mathcal{C}(S)$  *satisfies the Leray property* if each non-empty intersection  $S_{\alpha_0 \cdots \alpha_p}$  is contractible.

Clearly, in this case

$$\begin{aligned} H^0(S_{\alpha_0 \cdots \alpha_p}) &\cong \mathbb{Q}, & \text{if } S_{\alpha_0 \cdots \alpha_p} \neq \emptyset \\ &\cong 0, & \text{if } S_{\alpha_0 \cdots \alpha_p} = \emptyset. \end{aligned}$$

It is a classical fact (usually referred to as the *Nerve Lemma*) that

**Theorem 3.13** (Nerve Lemma). *Suppose that the cover  $\mathcal{C}(S)$  satisfies the Leray property. Then for each  $i \geq 0$ ,*

$$H^i(L^\bullet(\mathcal{C}(S))) \cong H^i(S).$$

(See for instance [68] for a proof.)

*Remark 3.14.* There are several interesting extensions of Theorem 3.13 (Nerve Lemma). For instance, if the Leray property is weakened to say that each  $t$ -ary intersection is  $(k - t + 1)$ -connected, then one can conclude that the nerve complex is  $k$ -connected. We refer the reader to the article by Björner [28] for more details.

Notice that Theorem 3.13 gives a method for computing the Betti numbers of  $S$  using linear algebra from a cover of  $S$  by contractible sets for which all non-empty intersections are also contractible, once we are able to test emptiness of the various intersections  $S_{\alpha_0 \dots \alpha_p}$ .

Now suppose that each individual member,  $S_{\alpha_0}$ , of the cover is contractible, but the various intersections  $S_{\alpha_0 \dots \alpha_p}$  are not necessarily contractible for  $p \geq 1$ . Theorem 3.13 does not hold in this case. However, the following theorem is proved in [18] and underlies the singly exponential algorithm for computing the first Betti number of semi-algebraic sets described there.

**Theorem 3.15.** [18] *Suppose that each individual member,  $S_{\alpha_0}$ , of the cover  $\mathcal{C}(S)$  is contractible. Then,*

$$H^i(L_2^\bullet(\mathcal{C}(S))) \cong H^i(S), \text{ for } i = 0, 1.$$

*Remark 3.16.* Notice that from a cover by contractible sets Theorem 3.15 allows us to compute using linear algebra,  $b_0(S)$  and  $b_1(S)$ , once we have identified the non-empty semi-algebraically connected components of the pair-wise and triple-wise intersections of the sets in the cover and their inclusion relationships.

3.2.1. *Constructing coverings of closed semi-algebraic sets by closed contractible sets.* The parametrized paths obtained in Theorem 3.9 are not necessarily closed or even contractible, but become so after making appropriate modifications. At the same time it is possible to maintain the covering property, namely for any given  $\mathcal{P}$ -closed semi-algebraic  $S$  set, there exists a set of modified parametrized paths, whose union is  $S$ . Moreover, these modified sets are closed and contractible. We omit the details of this (technical) construction referring the reader to [18] for more detail. Putting together the constructions outlined above we have:

**Theorem 3.17.** [18] *There exists an algorithm that given as input a  $\mathcal{P}$ -closed and bounded semi-algebraic set  $S$ , outputs a set of formulas  $\{\phi_1, \dots, \phi_M\}$  such that*

- each  $\mathcal{R}(\phi_i, \mathbb{R}^k)$  is semi-algebraically contractible, and
- $\bigcup_{1 \leq i \leq M} \mathcal{R}(\phi_i, \mathbb{R}^k) = \text{Ext}(S, \mathbb{R}^k)$ ,

where  $\mathbb{R}^k$  is some real closed extension of  $\mathbb{R}$ . The complexity of the algorithm is bounded by  $s^{(k+1)^2} d^{O(k^5)}$ , where  $s = \text{card } \mathcal{P}$  and  $d = \max_{P \in \mathcal{P}} \text{deg}(P)$ .

3.2.2. *Computing the First Betti Number.* It is now an easy consequence of the existence of singly exponential time covering algorithm (Theorem 3.17), and Theorem 3.15 stated above, along with the fact that we can compute descriptions of the semi-algebraically connected components of semi-algebraic sets in singly exponential time, that we can compute the first Betti number of closed and bounded semi-algebraic sets in singly exponential time (see Remark 3.16 above), since the dimensions of the images and kernels of the homomorphisms of the complex,  $L_2^\bullet(\mathcal{C}(S))$  in Theorem 3.15, can then be computed using traditional algorithms from linear algebra. As mentioned earlier, for arbitrary semi-algebraic sets (not necessarily closed and bounded), there is a singly exponential time reduction to the closed and bounded case using the construction of Gabrielov and Vorobjov [42].

3.2.3. *Algorithm for Computing the First Few Betti Numbers.* Using the same ideas as above but with a more complicated recursive procedure to construct a suitable complex one has the following:

**Theorem 3.18.** [9] *For any given  $\ell$ , there is an algorithm that takes as input a  $\mathcal{P}$ -formula describing a semi-algebraic set  $S \subset \mathbb{R}^k$ , and outputs  $b_0(S), \dots, b_\ell(S)$ . The complexity of the algorithm is  $(sd)^{k^{O(\ell)}}$ , where  $s = \text{card}(\mathcal{P})$  and  $d = \max_{P \in \mathcal{P}} \deg(P)$ .*

Note that the complexity is singly exponential in  $k$  for every fixed  $\ell$ .

**3.3. Computing generalized Euler-Poincaré characteristic.** As mentioned before in Section 2.4.1, efficient algorithms for sign determination of univariate polynomials described in [26, 69] are amongst the most basic algorithms in algorithmic real algebraic geometry. Given  $\mathcal{P} \subset \mathbb{R}[X], Q \in \mathbb{R}[X]$  with  $\text{card } \mathcal{P} = s$ , and  $\deg(P) \leq d$  for  $P \in \mathcal{P} \cup \{Q\}$ , these algorithms count for each realizable sign condition of the family  $\mathcal{P}$ , the cardinality of the set of real zeros of  $Q$ , lying in the realization of that sign condition. The complexity of the algorithm in [69] is  $sd^{O(1)}$ .

In the multidimensional case, it is no longer meaningful to talk about the cardinalities of the zero set of  $Q$  lying in the realizations of different sign conditions of  $\mathcal{P}$ . However, there exists another discrete valuation on semi-algebraic sets that properly generalizes the notion of cardinality. This valuation is the Euler-Poincaré characteristic.

The *Euler-Poincaré characteristic*,  $\chi(S)$ , of a closed and bounded semi-algebraic set  $S \subset \mathbb{R}^k$  is defined as

$$\chi(S) = \sum_i (-1)^i b_i(S),$$

where  $b_i(S)$  is the rank of the  $i$ -th simplicial homology group of  $S$ . Note that with this definition,  $\chi(\emptyset) = 0$ , and  $\chi(S) = \text{card } S$ , whenever  $\text{card } S < \infty$ . Moreover,  $\chi$  is additive.

The Euler-Poincaré characteristic defined above for closed and bounded semi-algebraic set can be extended additively to all semi-algebraic sets. This *generalized Euler-Poincaré characteristic* is then a homeomorphism (but not a homotopy) invariant, and establishes an isomorphism between the *Grothendieck ring,  $K_0(\text{sa})$* , of homeomorphism classes of semi-algebraic sets and  $\mathbb{Z}$ .

The problem of determining the Euler-Poincaré characteristic of  $\mathcal{P}$ -closed semi-algebraic sets was considered in [7] where an algorithm was presented for computing the Euler-Poincaré characteristic of a given  $\mathcal{P}$ -closed semi-algebraic set. The complexity of the algorithm is  $(ksd)^{O(k)}$ . Moreover, in the special case when the coefficients of the polynomials in  $\mathcal{P}$  are integers of bit lengths bounded by  $\tau$ , the algorithm performs at most  $(ksd)^{O(k)} \tau^{O(1)}$  bit operations.

The following result (which should be viewed as a generalization of the univariate sign determination algorithm) appears in [16].

**Theorem 3.19.** *There exists an algorithm which given an algebraic set  $Z = Z(Q, \mathbb{R}^k) \subset \mathbb{R}^k$  and a finite set of polynomials  $\mathcal{P} = \{P_1, \dots, P_s\} \subset \mathbb{R}[X_1, \dots, X_k]$ , computes the list  $\chi(\mathcal{P}, Z)$  indexed by elements,  $\sigma$ , of  $\text{Sign}(\mathcal{P}, Z)$ . If the degrees of the polynomials in  $\mathcal{P} \cup \{Q\}$  are bounded by  $d$ , and the real dimension of  $Z = Z(Q, \mathbb{R}^k)$  is  $k'$ , then the complexity of the algorithm is*

$$s^{k'+1} O(d)^k + s^{k'} ((k' \log_2(s) + k \log_2(d)) d)^{O(k)}.$$

If the coefficients of the polynomials in  $\mathcal{P} \cup \{Q\}$  are integers of bit-sizes bounded by  $\tau$ , then the bit-sizes of the integers appearing in the intermediate computations and the output are bounded by  $\tau((k' \log_2(s) + k \log_2(d))d)^{O(k)}$ .

**3.4. Relation between the complexity of quantifier elimination and the complexity of computing Betti numbers.** It is clear from the previous sections that there are two important strands of research in algorithms in real algebraic geometry, namely

- (1) Algorithms for deciding sentences in the first-order theory of the reals (with several blocks of quantifiers);
- (2) Computing topological invariants of semi-algebraic sets (such as their Betti numbers).

While these two classes of problems might seem quite different, the following reduction result gives a polynomial time reduction of the problem of deciding quantified sentences in the first order theory of the reals with a fixed number of quantifiers to the problem of computing Betti numbers of semi-algebraic sets. For technical reasons, the reduction is only proved for a certain sub-class of formulas which is defined more precisely below.

**Definition 3.20.** (Compact general decision problem with at most  $\omega$  quantifier alternations ( $\mathbf{GDP}_\omega^c$ ))

Input. A sentence  $\Phi$  in the first order theory of  $\mathbb{R}$

$$(Q_1 \mathbf{X}^1 \in \mathbf{S}^{k_1}) \dots (Q_\omega \mathbf{X}^\omega \in \mathbf{S}^{k_\omega}) \phi(\mathbf{X}^1, \dots, \mathbf{X}^\omega),$$

where for each  $i, 1 \leq i \leq \omega$ ,  $\mathbf{X}^i = (X_0^i, \dots, X_{k_i}^i)$  is a block of  $k_i + 1$  variables,  $Q_i \in \{\exists, \forall\}$ , with  $Q_j \neq Q_{j+1}, 1 \leq j < \omega$ , and  $\phi$  is a quantifier-free formula defining a *closed* semi-algebraic subset  $S$  of  $\mathbf{S}^{k_1} \times \dots \times \mathbf{S}^{k_\omega}$ .

Output. True or False depending on whether  $\Phi$  is true or false in the first order theory of  $\mathbb{R}$ .

NOTATION 4. For any semi-algebraic set  $S \subset \mathbb{R}^k$ , we denote by  $P_S(T)$ , denote the *Poincaré polynomial* of  $S$  – namely,

$$P_S(T) := \sum_{i \geq 0} b_i(S) T^i.$$

**Definition 3.21.** (Computing the Poincaré polynomial of semi-algebraic sets ( $\mathbf{Poincaré}$ ))

Input. A quantifier-free formula defining a semi-algebraic set  $S \subset \mathbb{R}^k$ .

Output. The Poincaré polynomial  $P_S(T)$ .

The following reduction result appears in [25]. It says that with a mild hypothesis of compactness, the General Decision Problem with a fixed number of quantifier alternations can be reduced in polynomial time to the problem of computing Betti numbers of semi-algebraic sets.

**Theorem 3.22.** [25] *For every  $\omega > 0$ , there is a deterministic polynomial time reduction of  $\mathbf{GDP}_\omega^c$  to  $\mathbf{Poincaré}$ .*

*Remark 3.23.* Theorem 3.22 is motivated by a well known theorem due to Toda [76] in discrete complexity theory which relates two complexity classes – namely the polynomial hierarchy and the complexity class  $\#\mathbf{P}$ . Theorem 3.22 can be viewed

as an analogue of Toda’s theorem in the Blum-Shub-Smale model of computations over arbitrary real closed fields [30] (see also [25]).

The main ingredients in the proof of Theorem 3.22 is an efficient semi-algebraic realization of the iterated fibered join of a semi-algebraic set with itself over a semi-algebraic map, and Alexander duality that allows one to express the Poincaré polynomial of a semi-algebraic subset of the sphere in terms of its complement in the sphere.

**3.5. Effective semi-algebraic triangulation and stratification.** As mentioned above in Section 2.1.2 one obtains an algorithm for computing a semi-algebraic triangulation of semi-algebraic sets using cylindrical algebraic decomposition (after making a generic linear change of co-ordinates). The complexity of this algorithm is dominated by the cost of the performing the cylindrical algebraic decomposition, and is thus doubly exponential.

Algorithms for computing stratifications of semi-algebraic sets, such that the strata satisfy additional regularity conditions (such as Whitney conditions (a) and (b)) have been considered by several authors. Rannou [65] gave an algorithm for obtaining stratification with regularity conditions that imply the Whitney conditions. The complexity of this algorithm is doubly exponential in the depth of the stratification. *Finding a singly exponential algorithm for computing stratifications of semi-algebraic sets remains a major open problem* (see Section 5).

**3.6. Semi-algebraic sets defined by quadratic and partially quadratic systems.** A restricted class of semi-algebraic sets - namely, semi-algebraic sets defined by quadratic inequalities - has been considered by several researchers [4, 5, 47]. As in the case of general semi-algebraic sets, the Betti numbers of such sets can be exponentially large in the number of variables, as can be seen in the following example.

**Example 3.24.** The set  $S \subset \mathbb{R}^\ell$  defined by

$$Y_1(Y_1 - 1) \geq 0, \dots, Y_\ell(Y_\ell - 1) \geq 0$$

satisfies  $b_0(S) = 2^\ell$ .

However, it turns out that for a semi-algebraic set  $S \subset \mathbb{R}^\ell$  defined by  $m$  quadratic inequalities, it is possible to obtain upper bounds on the Betti numbers of  $S$  which are polynomial in  $\ell$  and exponential only in  $m$ . The first such result is due to Barvinok [5], who proved the following theorem.

**Theorem 3.25.** [5] *Let  $S \subset \mathbb{R}^\ell$  be defined by  $Q_1 \geq 0, \dots, Q_m \geq 0$ ,  $\deg(Q_i) \leq 2, 1 \leq i \leq m$ . Then  $b(S) \leq \ell^{O(m)}$ .*

*Remark 3.26.* Notice that the bound in Theorem 3.25 is polynomial in the dimension  $\ell$  for fixed  $m$ , and this fact depends crucially on the assumption that the degrees of the polynomials  $Q_1, \dots, Q_m$  are at most two. For instance, the semi-algebraic set defined by a *single* polynomial of degree 4 can have Betti numbers exponentially large in  $\ell$ , as exhibited by the semi-algebraic subset of  $\mathbb{R}^\ell$  defined by

$$\sum_{i=0}^{\ell} Y_i^2(Y_i - 1)^2 \leq 0.$$



The above example illustrates the delicate nature of the bound in Theorem 3.25, since a single inequality of degree 4 is enough to destroy the polynomial nature of the bound. In contrast to this, it is shown in Theorem 3.31 below that a polynomial bound on the Betti numbers of  $S$  continues to hold, even if we allow a few (meaning any constant number) of the variables to occur with degrees larger than two in the polynomials used to describe the set  $S$ .

The bound on the sum of all the Betti numbers in Theorem 3.25 has exponential dependence on the number of inequalities. This dependence is unavoidable, since the semi-algebraic set  $S \subset \mathbb{R}^k$  defined by

$$X_1(1 - X_1) \leq 0, \dots, X_k(1 - X_k) \leq 0,$$

has  $b_0(S) = 2^k$ .

Hence, it is somewhat surprising that for any fixed constant  $\ell$ , the Betti numbers  $b_{k-1}(S), \dots, b_{k-\ell}(S)$ , of a basic closed semi-algebraic set  $S \subset \mathbb{R}^k$  defined by quadratic inequalities, are polynomially bounded. The following theorem appears in [8].

**Theorem 3.27.** *Let  $\mathbb{R}$  a real closed field and  $S \subset \mathbb{R}^k$  be defined by*

$$P_1 \leq 0, \dots, P_s \leq 0, \deg(P_i) \leq 2, 1 \leq i \leq s.$$

*Then, for  $\ell \geq 0$ ,*

$$b_{k-\ell}(S) \leq \binom{s}{\ell} k^{O(\ell)}.$$

3.6.1. *Algorithm for testing emptiness.* The problem of deciding whether a given semi-algebraic set defined by a finite set of quadratic inequalities is empty or not was considered first by Barvinok [4] who proved the following theorem.

**Theorem 3.28.** [4] *There exists an algorithm which decides if a given system of inequalities  $Q_1 \geq 0, \dots, Q_\ell \geq 0$ , with each  $Q_i \in \mathbb{R}[X_1, \dots, X_k]$ ,  $\deg(Q_i) \leq 2$ , has a solution in  $\mathbb{R}^k$ , whose complexity is bounded by  $k^{O(\ell)}$ .*

Barvinok’s algorithm did not produce explicit sample points meeting every semi-algebraically connected component of the set of solutions (in the style of Theorem 2.15 in the general case). This was done by Grigoriev and Pasechnik [47]. In fact, they consider the following more general situation.

Let  $S \subset \mathbb{R}^k$  be the pull-back of a  $\mathcal{P}$ -semi-algebraic subset  $T \subset \mathbb{R}^\ell$  via a quadratic map  $Q = (Q_1, \dots, Q_\ell) : \mathbb{R}^k \rightarrow \mathbb{R}^\ell$ , where  $\mathcal{P} \subset \mathbb{R}[Y_1, \dots, Y_\ell]$ ,  $Q_1, \dots, Q_\ell \in \mathbb{R}[X_1, \dots, X_k]$  with  $\deg(Q_i) \leq 2$  for  $i = 1, \dots, \ell$ .

In [47], Grigoriev and Pasechnik give an algorithm that computes a set of sample points guaranteed to meet every semi-algebraically connected component of  $S$  whose complexity is bounded by  $(ksd)^{O(\ell)}$  where  $s = \text{card } \mathcal{P}$ , and  $d$  is a bound on the degrees of the polynomials in  $\mathcal{P}$ .

*Remark 3.29.* Note that the problem of deciding the feasibility of even one quartic real polynomial equation is an **NP**-hard problem, and the same is true for systems of quadratic equations. Thus, there is little hope for obtaining a polynomial-time algorithm for either of these problems. The above results are somewhat surprising in that they imply in the quadratic case one obtains polynomial time algorithms for testing feasibility, provided the number of polynomials is kept fixed (see also Section 3.6.3 below). We refer the reader to [58] and [30] for precise definitions of

the computational complexity classes that we refer to here and elsewhere in this survey.

3.6.2. *Computing the top few Betti numbers of basic semi-algebraic sets defined by quadratic inequalities.* Motivated by the polynomial bound on the top few Betti numbers of sets defined by quadratic inequalities (Theorem 3.27), the problem of obtaining a polynomial time algorithm to compute these numbers was investigated in [11] where the following result is proved.

**Theorem 3.30.** [11] *There exists an algorithm which given a set of  $s$  polynomials,  $\mathcal{P} = \{P_1, \dots, P_s\} \subset \mathbb{R}[X_1, \dots, X_k]$ , with  $\deg(P_i) \leq 2, 1 \leq i \leq s$ , computes  $b_{k-1}(S), \dots, b_{k-\ell}(S)$ , where  $S$  is the set defined by  $P_1 \leq 0, \dots, P_s \leq 0$ . The complexity of the algorithm is*

$$(3.4) \quad \sum_{i=0}^{\ell+2} \binom{s}{i} k^{2^{O(\min(\ell, s))}}.$$

*If the coefficients of the polynomials in  $\mathcal{P}$  are integers of bit-sizes bounded by  $\tau$ , then the bit-sizes of the integers appearing in the intermediate computations and the output are bounded by  $\tau(sk)^{2^{O(\min(\ell, s))}}$ .*

3.6.3. *Significance from the computational complexity theory viewpoint.* Semi-algebraic sets defined by a system of quadratic inequalities have a special significance in the theory of computational complexity. Even though such sets might seem to be the next simplest class of semi-algebraic sets after sets defined by linear inequalities, from the point of view of computational complexity they represent a quantum leap. Whereas there exist (weakly) polynomial time algorithms for solving linear programming, solving quadratic feasibility problem is provably hard. For instance, it follows from an easy reduction from the problem of testing feasibility of a real quartic equation in many variables, that the problem of testing whether a system of quadratic inequalities is feasible is  $\mathbf{NP}_{\mathbb{R}}$ -complete in the Blum-Shub-Smale model of computation (see [30]). Assuming the input polynomials to have integer coefficients, the same problem is  $\mathbf{NP}$ -hard in the classical Turing machine model, since it is also not difficult to see that the Boolean satisfiability problem can be posed as the problem of deciding whether a certain semi-algebraic set defined by quadratic inequalities is empty or not. Counting the number of semi-algebraically connected components of such sets is even harder. In fact, it is  $\mathbf{PSPACE}$ -hard [66] ( $\mathbf{PSPACE}$  is a complexity class which contains the entire polynomial hierarchy), and the proof of this result extends easily to the quadratic case. Moreover, it is proved in [11] for  $\ell = O(\log k)$ , computing the  $\ell$ -th Betti number of a basic semi-algebraic set defined by quadratic inequalities in  $\mathbb{R}^k$  is  $\mathbf{PSPACE}$ -hard. In view of these hardness results, it is unlikely that there exist polynomial time algorithms for computing the Betti numbers (or even the first few Betti numbers) of such a set.

From this point of view, Theorem 3.30 is quite surprising, since it gives a polynomial time algorithm for computing certain Betti numbers of a class of semi-algebraic sets for which computing the zero-th Betti number is already  $\mathbf{PSPACE}$ -hard.

3.6.4. *Semi-algebraic sets defined by partially quadratic systems.* We have discussed topological as well as algorithmic results concerning general semi-algebraic sets, as well as those defined by quadratic constraints. In [24], the authors try to interpolate between results known for general semi-algebraic sets (defined by polynomials

of arbitrary degrees) and those known for semi-algebraic sets defined by polynomials of degree at most 2. In order to do so they consider semi-algebraic sets defined by polynomial inequalities, in which the dependence of the polynomials on a *subset of the variables* is at most quadratic. As a result we obtain common generalizations of the bounds stated in Theorems 3.2 and 3.25. Given any polynomial  $P \in \mathbb{R}[X_1, \dots, X_k, Y_1, \dots, Y_\ell]$ , we will denote by  $\deg_X(P)$  (resp.  $\deg_Y(P)$ ) the total degree of  $P$  with respect to the variables  $X_1, \dots, X_k$  (resp.  $Y_1, \dots, Y_\ell$ ).

Denote by

- $\mathcal{Q} \subset \mathbb{R}[Y_1, \dots, Y_\ell, X_1, \dots, X_k]$ , a family of polynomials with  $\deg_Y(Q) \leq 2, \deg_X(Q) \leq d, Q \in \mathcal{Q}, \text{card } \mathcal{Q} = m,$
- $\mathcal{P} \subset \mathbb{R}[X_1, \dots, X_k]$ , a family of polynomials with  $\deg_X(P) \leq d, P \in \mathcal{P}, \text{card } \mathcal{P} = s.$

The following theorem that interpolates between Theorems 3.1 and 3.25 above is proved in [24].

**Theorem 3.31.** *Let  $S \subset \mathbb{R}^{\ell+k}$  be a  $(\mathcal{P} \cup \mathcal{Q})$ -closed semi-algebraic set. Then*

$$b(S) \leq \ell^2(O(s + \ell + m)\ell d)^{k+2m}.$$

*In particular, for  $m \leq \ell$ , we have  $b(S) \leq \ell^2(O(s + \ell)\ell d)^{k+2m}.$*

Notice that Theorem 3.31 can be seen as a common generalization of Theorems 3.2 and 3.25, in the sense that we recover similar bounds (that is bounds having the same shape) as in Theorem 3.2 (respectively Theorem 3.25) by setting  $\ell$  and  $m$  (respectively  $s, d$  and  $k$ ) to  $O(1)$ .

Note also that as a special case of Theorem 3.31 we obtain a bound on the sum of the Betti numbers of a semi-algebraic set defined over a quadratic map. As mentioned before, such sets have been considered from an algorithmic point of view in [47], where an efficient algorithm is described for computing sample points in every semi-algebraically connected component, as well as testing emptiness, of such sets.

More precisely we have:

**Corollary 3.32.** *Let  $Q = (Q_1, \dots, Q_k) : \mathbb{R}^\ell \rightarrow \mathbb{R}^k$  be a map where each  $Q_i \in \mathbb{R}[Y_1, \dots, Y_\ell]$  and  $\deg(Q_i) \leq 2$ . Let  $V \subset \mathbb{R}^k$  be a  $\mathcal{P}$ -closed semi-algebraic set for some family  $\mathcal{P} \subset \mathbb{R}[X_1, \dots, X_k]$ , with  $\text{card } \mathcal{P} = s$  and  $\deg(P) \leq d, P \in \mathcal{P}$ . Let  $S = Q^{-1}(V)$ . Then*

$$b(S) \leq \ell^2(O(s + \ell + k)\ell d)^{3k}.$$

The techniques developed in this paper for obtaining tight bounds on the Betti numbers of semi-algebraic sets defined by partly quadratic systems of polynomials also pave the way towards designing more efficient algorithms for computing the Euler-Poincaré characteristic as well as the Betti numbers of such sets.

The following theorem appears in [24].

**Theorem 3.33.** *There exists an algorithm that takes as input the description of a  $(\mathcal{P} \cup \mathcal{Q})$ -closed semi-algebraic set  $S$  (following the same notation as in Theorem 3.31) and outputs its the Euler-Poincaré characteristic  $\chi(S)$ . The complexity of this algorithm is bounded by  $(\ell s m d)^{O(m(m+k))}$ . In the case when  $S$  is a basic closed semi-algebraic set the complexity of the algorithm is  $(\ell s m d)^{O(m+k)}$ .*

The algorithm for computing all the Betti numbers has complexity  $(lsm d)^{2^{O(m+k)}}$  and its description can be found in [23]. While the complexity of both the algorithms discussed above is *polynomial* for fixed  $m$  and  $k$ , the complexity of the algorithm for computing the Euler-Poincaré characteristic is significantly better than that of the algorithm for computing all the Betti numbers.

Note that the first versions of both these algorithms for computing the Euler-Poincaré characteristic as well as the Betti numbers of semi-algebraic sets defined by purely quadratic constraints having complexity which is polynomial for fixed number of constraints, appeared first in [10] and [11] respectively. The extensions of these algorithms to semi-algebraic sets defined by partially quadratic systems were made in [24] and [23] respectively.

These latter results indicate that the problem of computing the Betti numbers of semi-algebraic sets defined by a constant number of polynomial inequalities is solvable in polynomial time, even if we allow a small (constant sized) subset of the variables to occur with degrees larger than two in the polynomials defining the given set.

#### 4. SUMS OF SQUARES AND SEMI-DEFINITE PROGRAMMING

All the algorithms surveyed above have the feature that they are exact, and most of them work over arbitrary real closed fields (even non-archimedean ones). For example, the ring generated by the coefficients,  $D$ , could be the ordered ring,  $\mathbb{Z}[\varepsilon]$  with  $\varepsilon$  positive and infinitesimal, contained in the real closed field  $\mathbb{R} = \mathbb{R}_{\text{alg}}(\varepsilon)$  and all algorithms reported above would still work without any modification.

There are some other approaches to designing algorithms for solving systems of real polynomial equations or testing emptiness of semi-algebraic sets that deserve mention. These approaches strictly assume that the underlying real closed field is the field  $\mathbb{R}$  of real numbers, and the computations are done with some finite precision. In other words, the algorithms are numerical rather than exact, and as such there is some possibility of error in the outputs. These algorithms are often used in practical applications, where exact or symbolic algorithms are deemed to be too expensive and small errors are considered not very significant.

We mention one such approach below.

**4.1. Deciding non-negativity of polynomials using sums-of-squares.** The problem is to decide whether a given polynomial  $P \in \mathbb{R}[X_1, \dots, X_k]$  is non-negative in  $\mathbb{R}^k$ . More generally, the problem is to decide whether a given polynomial  $P \in \mathbb{R}[X_1, \dots, X_k]$  is non-negative over a given basic, semi-algebraic subset  $K \subset \mathbb{R}^k$ .

There are also optimization versions of these problems namely.

Given  $P \in \mathbb{R}[X_1, \dots, X_k]$  compute

$$p^{\min} := \inf_{x \in \mathbb{R}^k} P(x).$$

More generally, Given  $P \in \mathbb{R}[X_1, \dots, X_k]$  and  $K \subset \mathbb{R}^k$  a basic semi-algebraic set, compute

$$p^{\min} := \inf_{x \in K} P(x).$$

For purposes of exposition we concentrate on the first versions of these problems.

Let the degree of  $P$  be  $2d$  and let  $\text{Pos}_{k,d}$  (resp.  $\Sigma_{k,d}$ ) denote the cone of non-negative polynomials (resp. cone of sum of squares) in  $\mathbb{R}[X_1, \dots, X_k]$  of degree at most  $2d$ . Clearly  $\Sigma_{k,d} \subset \text{Pos}_{k,d}$  and as known since Hilbert, the inclusion is strict

unless the pair  $(k, d)$  is of the form  $(1, d)$ ,  $(k, 1)$  or  $(k, d) = (2, 2)$  [31, Chapter 6]. Note that the cones  $\text{Pos}_{k,d}$  are in general not understood very well (for instance, their face structure, extreme rays etc.) and testing membership in them is clearly an NP-hard problem. On the other hand, the cones  $\Sigma_{k,d}$  are relatively well understood and membership in  $\Sigma_{k,d}$  can be tested via semi-definite programming as a result of the following theorem.

For any symmetric, square matrix  $X \in \mathbb{R}^{k \times k}$ , we let  $X \succeq 0$  denote that  $X$  is positive, semi-definite. For each  $k, d \geq 0$ , we denote by  $\mathcal{M}_{k,d}$  the set of exponent vectors  $\alpha = (\alpha_1, \dots, \alpha_k) \in \mathbb{N}^k$  with  $|\alpha| = \sum_{i=1}^k \alpha_i \leq d$ .

**Theorem 4.1.** [34, 63] *The following are equivalent.*

- (1)  $P = \sum_{\alpha \in \mathcal{M}_{k,d}} p_\alpha X^\alpha \in \Sigma_{k,d}$ .
- (2) *The following system in matrix variables  $X = (X_{\alpha,\beta})_{\alpha,\beta \in \mathcal{M}_{k,d}}$  is feasible:*

$$\begin{aligned} X &\succeq 0 \\ \sum_{\beta, \gamma \in \mathcal{M}_{k,d}, \beta + \gamma = \alpha} X_{\beta,\gamma} &= p_\alpha, \alpha \in \mathcal{M}_{k,2d}. \end{aligned}$$

The feasibility problem in the above theorem is an instance of the feasibility problem in the theory of *semi-definite programming*. Semi-definite programming (or semi-definite optimization) is a generalization of linear programming, where the problem is to optimize a linear functional over some affine section of the cone of real symmetric positive semi-definite matrices in the space of  $k \times k$  real symmetric matrices. Because of its wide ranging applicability, semi-definite programming has been the focus of intense effort on the part of researchers in optimization for developing efficient algorithms for solving semi-definite programming problems. As a result very efficient algorithms based on “interior point methods” (see [57]) have been developed for solving semi-definite optimization problems such as the one in Theorem 4.1. These algorithms are very efficient in practice, but there seems to be no definitive mathematical result which states that the running time is polynomial (in the bit-size of the input) (unlike in the case of linear programming).

Note that the polynomial optimization problems can also be “approximated” using the sum of squares cone just like above. For example, in order to compute

$$p^{\min} := \inf_{x \in \mathbb{R}^k} P(x) = \sup\{\rho \in \mathbb{R} \mid P - \rho \in \text{Pos}_{k,d}\},$$

one computes

$$p^{\text{sos}} := \sup\{\rho \in \mathbb{R} \mid P - \rho \in \Sigma_{k,d}\}.$$

Since, this latter problem is an example of semi-definite *optimization* problem and can be solved in practice using efficient interior points methods. Also note that since the latter problem involves optimization over a smaller cone we have that

$$p^{\text{sos}} \leq p^{\min}.$$

The idea of “relaxing” polynomial optimization problems to semi-definite programming has been utilized by Lasserre [50, 52, 51], Parrilo [59] and others to obtain algorithms for performing polynomial optimization which perform well in practice (but see Remark 4.2 below).

*Remark 4.2.* While the idea of approximating the cone of non-negative polynomials by the smaller cone of sums of square seems to work well in practice for solving or approximating well solutions of polynomial optimization problems, one should

be aware of certain negative results. Blekherman [29] proved that the ratio of the volumes of certain fixed sections of the cones  $\Sigma_{k,d}$  and  $\text{Pos}_{k,d}$  goes to 0 with  $k$  exponentially fast. This seems to indicate that the approximation of  $\text{Pos}_{k,d}$  by  $\Sigma_{k,d}$  is very inaccurate as  $k$  grows (with  $d$  fixed).

We refer the reader to the excellent survey article by Laurent [53] for more detailed information about the sums-of-squares methods in algorithmic real algebraic geometry.

**4.2. Complexity of semi-definite programming.** Since semi-definite optimization problems play an important role in the sums-of-square approximation algorithms described above, it is important to be aware of the current complexity status of this problem. As noted above, while interior points algorithms for solving semi-definite programming problems are extremely efficient in practice, there is no definite result known placing the semi-definite programming problem in the class  $\mathbf{P}$ . Khachiyan and Prokolab [62] proved that there exists a polynomial time algorithm for semi-definite programming in case the dimension is fixed. Using results proved by Ramana [64] on exact semi-definite duality theory, it can be deduced (see [73]) that semi-definite feasibility cannot be  $\mathbf{NP}$ -complete unless  $\mathbf{NP} = \mathbf{co-NP}$  (a hypothesis not believed to be true). In the Blum-Shub-Smale model of computation over real machines [30], the semi-definite feasibility problem is clearly in the class  $\mathbf{NP}_{\mathbb{R}}$ , and it is unknown if it is any easier than ordinary real polynomial feasibility problem in this model.

## 5. OPEN PROBLEMS

We list here some interesting open problems some of which could possibly be tackled in the near future.

*Computing Betti numbers in singly exponential time ?* Suppose  $S \subset \mathbb{R}^k$  is a semi-algebraic set defined in terms of  $s$  polynomials, of degrees bounded by  $d$ . One of the most fundamental open questions in algorithmic semi-algebraic geometry, is whether there exists a singly exponential (in  $k$ ) time algorithm for computing the Betti numbers of  $S$ . The best we can do so far is summarized in Theorem 3.18 which gives the existence of singly exponential time algorithms for computing the first  $\ell$  Betti numbers of  $S$  for any constant  $\ell$ . A big challenge is to extend these ideas to design an algorithm for computing all the Betti numbers of  $S$ .

*Computing semi-algebraic triangulations in singly exponential time ?* A related question is whether there exists an algorithm for computing semi-algebraic triangulations with singly exponential complexity. Clearly, such an algorithm would also make possible the computation of Betti numbers in singly exponential time.

*More Efficient Algorithms for Computing the Number of Connected Components in the Quadratic Case ?* As described in Section 3.6 for semi-algebraic sets in  $\mathbb{R}^k$  defined by  $\ell$  quadratic inequalities, there are algorithms for deciding emptiness, as well as computing sample points in every semi-algebraically connected component whose complexity is bounded by  $k^{O(\ell)}$ . We also have an algorithm for computing the Euler-Poincaré characteristic of such sets whose complexity is  $k^{O(\ell)}$ . However, the best known algorithm for computing the number of semi-algebraically connected

components of such sets has complexity  $k^{2^{O(\ell)}}$  (as a special case of the algorithm for computing all the Betti numbers given in Theorem 3.27). This raises the question whether there exists a more efficient algorithm with complexity  $k^{O(\ell)}$  or even  $k^{O(\ell^2)}$  for counting the number of semi-algebraically connected components of such sets. Roadmap type constructions used for counting semi-algebraically connected components in the case of general semi-algebraic sets cannot be directly employed in this context, because such algorithms will have complexity exponential in  $k$ . Recent work by Coste and Moussa [38] on the geodesic diameter of semi-algebraic sets defined by few quadratic inequalities might contain some relevant hints towards this goal.

*More Efficient Algorithms for Computing the Number of Connected Components for General Semi-algebraic Sets ?* A very interesting open question is whether the exponent  $O(k^2)$  in the complexity of roadmap algorithms (cf. Theorem 3.6) can be improved to  $O(k)$ , so that the complexity of testing connectivity becomes asymptotically the same as that of testing emptiness of a semi-algebraic set (cf. Theorem 2.15). Recent improvements in the complexity of roadmap algorithms described in Section 3.1.2 above, certainly gives some hope in this regard.

Such an improvement would go a long way in making this algorithm practically useful. It would also be of interest for studying metric properties of semi-algebraic sets because of the following. Applying Crofton's formula from integral geometry one immediately obtains as a corollary of Theorem 3.6 (using the same notation as in the theorem) an upper bound of  $s^{k'+1}d^{O(k^2)}$  on the length of a semi-algebraic connecting path connecting two points in any semi-algebraically connected component of  $S$  (assuming that  $S$  is contained in the unit ball centered at the origin). An improvement in the complexity of algorithms for constructing connecting paths (such as the roadmap algorithm) would also improve the bound on the length of connecting paths. Recent results due to D'Acunto and Kurdyka [39] show that it is possible to construct semi-algebraic paths of length  $d^{O(k)}$  between two points of  $S$  (assuming that  $S$  is a semi-algebraically connected component of a real algebraic set contained in the unit ball defined by polynomials of degree  $d$ ). However, the semi-algebraic complexity of such paths cannot be bounded in terms of the parameters  $d$  and  $k$ . The improvement in the complexity suggested above, apart from its algorithmic significance, would also be an effective version of the results in [39].

*Remove the compactness assumption in Theorem 3.22.* More generally, investigate the role of compactness in the Blum-Shub-Smale model of computations over real closed fields (see [25] for more details).

## 6. ACKNOWLEDGMENT

The author was partially supported by an NSF grant CCF-0915954.

## REFERENCES

- [1] B. Bank, M. Giusti, J. Heintz, and G. M. Mbakop. Polar varieties, real equation solving, and data structures: the hypersurface case. *J. Complexity*, 13(1):5–27, 1997.
- [2] B. Bank, M. Giusti, J. Heintz, and G. M. Mbakop. Polar varieties and efficient real elimination. *Math. Z.*, 238(1):115–144, 2001.
- [3] Bernd Bank, Marc Giusti, Joos Heintz, Mohab Safey El Din, and Eric Schost. On the geometry of polar varieties. *Appl. Algebra Engrg. Comm. Comput.*, 21(1):33–83, 2010.

- [4] A. I. Barvinok. Feasibility testing for systems of real quadratic equations. *Discrete Comput. Geom.*, 10(1):1–13, 1993.
- [5] A. I. Barvinok. On the Betti numbers of semialgebraic sets defined by few quadratic inequalities. *Math. Z.*, 225(2):231–244, 1997.
- [6] S. Basu. New results on quantifier elimination over real closed fields and applications to constraint databases. *J. ACM*, 46(4):537–555, 1999.
- [7] S. Basu. On bounding the Betti numbers and computing the Euler characteristic of semi-algebraic sets. *Discrete Comput. Geom.*, 22(1):1–18, 1999.
- [8] S. Basu. Different bounds on the different Betti numbers of semi-algebraic sets. *Discrete Comput. Geom.*, 30(1):65–85, 2003. ACM Symposium on Computational Geometry (Medford, MA, 2001).
- [9] S. Basu. Computing the first few Betti numbers of semi-algebraic sets in single exponential time. *J. Symbolic Comput.*, 41(10):1125–1154, 2006.
- [10] S. Basu. Efficient algorithm for computing the Euler-Poincaré characteristic of a semi-algebraic set defined by few quadratic inequalities. *Comput. Complexity*, 15(3):236–251, 2006.
- [11] S. Basu. Computing the top few Betti numbers of semi-algebraic sets defined by quadratic inequalities in polynomial time. *Found. Comput. Math.*, 8(1):45–80, 2008.
- [12] S. Basu, R. Pollack, and M.-F. Roy. On the combinatorial and algebraic complexity of quantifier elimination. *J. ACM*, 43(6):1002–1045, 1996.
- [13] S. Basu, R. Pollack, and M.-F. Roy. On computing a set of points meeting every cell defined by a family of polynomials on a variety. *J. Complexity*, 13(1):28–37, 1997.
- [14] S. Basu, R. Pollack, and M.-F. Roy. Computing roadmaps of semi-algebraic sets on a variety. *J. Amer. Math. Soc.*, 13(1):55–82, 2000.
- [15] S. Basu, R. Pollack, and M.-F. Roy. Betti number bounds, applications and algorithms. In *Current Trends in Combinatorial and Computational Geometry: Papers from the Special Program at MSRI*, volume 52 of *MSRI Publications*, pages 87–97. Cambridge University Press, 2005.
- [16] S. Basu, R. Pollack, and M.-F. Roy. Computing the Euler-Poincaré characteristics of sign conditions. *Comput. Complexity*, 14(1):53–71, 2005.
- [17] S. Basu, R. Pollack, and M.-F. Roy. *Algorithms in real algebraic geometry*, volume 10 of *Algorithms and Computation in Mathematics*. Springer-Verlag, Berlin, 2006 (second edition).
- [18] S. Basu, R. Pollack, and M.-F. Roy. Computing the first Betti number of a semi-algebraic set. *Found. Comput. Math.*, 8(1):97–136, 2008.
- [19] S. Basu, R. Pollack, and M.-F. Roy. *Algorithms in real algebraic geometry*, volume 10 of *Algorithms and Computation in Mathematics*. Springer-Verlag, Berlin, 2009, online version posted on 07/31/2009, available at <http://perso.univ-rennes1.fr/marie-francoise.roy/bpr-ed2-posted1.html>.
- [20] S. Basu and M.-F. Roy. Bounding the radii of balls meeting every connected component of semi-algebraic sets. *J. Symbolic Comput.*, 45(12):1270–1279, 2010.
- [21] Saugata Basu, Marie-Françoise Roy, Mohab Safey El Din, and Eric Schost. Baby step-giant step roadmap algorithm for general algebraic sets. *manuscript*.
- [22] Saugata Basu, Andrei Gabrielov, and Nicolai Vorobjov. Semi-monotone sets. *arXiv:1004.5047v1 [math.LO]*.
- [23] Saugata Basu, Dmitrii V. Pasechnik, and Marie-Françoise Roy. Computing the Betti numbers of semi-algebraic sets defined by partly quadratic systems of polynomials. *J. Algebra*, 321(8):2206–2229, 2009.
- [24] Saugata Basu, Dmitrii V. Pasechnik, and Marie-Françoise Roy. Bounding the Betti numbers and computing the Euler-Poincaré characteristic of semi-algebraic sets defined by partly quadratic systems of polynomials. *J. Eur. Math. Soc. (JEMS)*, 12(2):529–553, 2010.
- [25] Saugata Basu and Thierry Zell. Polynomial hierarchy, Betti numbers, and a real analogue of Toda’s theorem. *Found. Comput. Math.*, 10(4):429–454, 2010.
- [26] M. Ben-Or, D. Kozen, and J. Reif. The complexity of elementary algebra and geometry. *J. of Computer and Systems Sciences*, 18:251–264, 1986.
- [27] Michael Benedikt, Guozhu Dong, Leonid Libkin, and Limsoon Wong. Relational expressive power of constraint query languages. *J. ACM*, 45(1):1–34, 1998.
- [28] A. Björner. Topological methods. In R. Graham, M. Grötschel, and L. Lovász, editors, *Handbook of Combinatorics*, volume II, pages 1819–1872. North-Holland/Elsevier, 1995.



- [29] Grigoriy Blekherman. There are significantly more nonnegative polynomials than sums of squares. *Israel J. Math.*, 153:355–380, 2006.
- [30] L. Blum, F. Cucker, M. Shub, and S. Smale. *Complexity and real computation*. Springer-Verlag, New York, 1998. With a foreword by Richard M. Karp.
- [31] J. Bochnak, M. Coste, and M.-F. Roy. *Géométrie algébrique réelle (Second edition in english: Real Algebraic Geometry)*, volume 12 (36) of *Ergebnisse der Mathematik und ihrer Grenzgebiete [Results in Mathematics and Related Areas ]*. Springer-Verlag, Berlin, 1987 (1998).
- [32] F. Boudaoud, F. Caruso, and M.-F. Roy. Certificates of positivity in the Bernstein basis. *Discrete Comput. Geom.*, 39(4):639–655, 2008.
- [33] J. Canny. Computing road maps in general semi-algebraic sets. *The Computer Journal*, 36:504–514, 1993.
- [34] M. D. Choi, T. Y. Lam, and B. Reznick. Sums of squares of real polynomials. In *K-theory and algebraic geometry: connections with quadratic forms and division algebras (Santa Barbara, CA, 1992)*, volume 58 of *Proc. Sympos. Pure Math.*, pages 103–126. Amer. Math. Soc., Providence, RI, 1995.
- [35] G. E. Collins. Quantifier elimination for real closed fields by cylindric algebraic decomposition. In *Second GI Conference on Automata Theory and Formal Languages*, volume 33 of *Lecture Notes in Computer Science*, pages 134–183, Berlin, 1975. Springer-Verlag.
- [36] G.E. Collins. Quantifier elimination for real closed fields by cylindrical algebraic decomposition. *LNCS*, 33:134–183, 1975.
- [37] M. Coste and M.-F. Roy. Thom’s lemma, the coding of real algebraic numbers and the topology of semi-algebraic sets. *Journal of Symbolic Computation*, 5(1/2):121–129, 1988.
- [38] Michel Coste and Seydou Moussa. Geodesic diameter of sets defined by few quadratic equations and inequalities. *arXiv:1004.5047v1 [math.LO]*.
- [39] D. D’Acunto and K. Kurdyka. Bounds for gradient trajectories and geodesic diameter of real algebraic sets. *Bull. London Math. Soc.*, 38(6):951–965, 2006.
- [40] James H. Davenport and Joos Heintz. Real quantifier elimination is doubly exponential. *J. Symbolic Comput.*, 5(1-2):29–35, 1988.
- [41] Mohab Safey el Din and Eric Schost. A baby steps/giant steps probabilistic algorithm for computing roadmaps in smooth bounded real hypersurface. *Discrete Comput. Geom.*, 45(1):181–220, 2010.
- [42] A. Gabrielov and N. Vorobjov. Betti numbers of semialgebraic sets defined by quantifier-free formulae. *Discrete Comput. Geom.*, 33(3):395–401, 2005.
- [43] Andrei Gabrielov and Nicolai Vorobjov. Approximation of definable sets by compact families, and upper bounds on homotopy and homology. *J. Lond. Math. Soc. (2)*, 80(1):35–54, 2009.
- [44] L. Gournay and J. J. Risler. Construction of roadmaps of semi-algebraic sets. *Appl. Algebra Eng. Commun. Comput.*, 4(4):239–252, 1993.
- [45] D. Grigoriev and N. Vorobjov. Counting connected components of a semi-algebraic set in subexponential time. *Comput. Complexity*, 2(2):133–186, 1992.
- [46] D. Yu. Grigoriev and N. N. Vorobjov, Jr. Solving systems of polynomial inequalities in subexponential time. *J. Symbolic Comput.*, 5(1-2):37–64, 1988.
- [47] Dima Grigoriev and Dmitrii V. Pasechnik. Polynomial-time computing over quadratic maps. I. Sampling in real algebraic sets. *Comput. Complexity*, 14(1):20–52, 2005.
- [48] J. Heintz, M.-F. Roy, and P. Solernò. Description of the connected components of a semialgebraic set in single exponential time. *Discrete and Computational Geometry*, 11:121–140, 1994.
- [49] Gabriela Jeronimo, Daniel Perrucci, and Juan Sabia. On sign conditions over real multivariate polynomials. *Discrete Comput. Geom.*, 44(1):195–222, 2010.
- [50] Jean B. Lasserre. Global optimization with polynomials and the problem of moments. *SIAM J. Optim.*, 11(3):796–817 (electronic), 2000/01.
- [51] Jean B. Lasserre. Convergent SDP-relaxations in polynomial optimization with sparsity. *SIAM J. Optim.*, 17(3):822–843 (electronic), 2006.
- [52] Jean B. Lasserre. A sum of squares approximation of nonnegative polynomials. *SIAM J. Optim.*, 16(3):751–765 (electronic), 2006.
- [53] Monique Laurent. Sums of squares, moment matrices and optimization over polynomials. In *Emerging applications of algebraic geometry*, volume 149 of *IMA Vol. Math. Appl.*, pages 157–270. Springer, New York, 2009.

- [54] S. Lojasiewicz. Triangulation of semi-analytic sets. *Ann. Scuola Norm. Sup. Pisa, Sci. Fis. Mat.*, 18(3):449–474, 1964.
- [55] J. Milnor. On the Betti numbers of real varieties. *Proc. Amer. Math. Soc.*, 15:275–280, 1964.
- [56] L. G. Monk. *Elementary-recursive decision procedures*. PhD thesis, UC Berkeley, 1975.
- [57] Yurii Nesterov and Arkadii Nemirovskii. *Interior-point polynomial algorithms in convex programming*, volume 13 of *SIAM Studies in Applied Mathematics*. Society for Industrial and Applied Mathematics (SIAM), Philadelphia, PA, 1994.
- [58] C. Papadimitriou. *Computational Complexity*. Addison-Wesley, 1994.
- [59] Pablo A. Parrilo. Semidefinite programming relaxations for semialgebraic problems. *Math. Program.*, 96(2, Ser. B):293–320, 2003. Algebraic and geometric methods in discrete optimization.
- [60] Daniel Perrucci. Linear solving for sign determination. *arXiv:0911.5707v1 [math.AG]*.
- [61] I. G. Petrovskii and O. A. Oleinik. On the topology of real algebraic surfaces. *Izvestiya Akad. Nauk SSSR. Ser. Mat.*, 13:389–402, 1949.
- [62] Lorant Porkolab and Leonid Khachiyan. On the complexity of semidefinite programs. *J. Global Optim.*, 10(4):351–365, 1997.
- [63] Victoria Powers and Thorsten Wörmann. An algorithm for sums of squares of real polynomials. *J. Pure Appl. Algebra*, 127(1):99–104, 1998.
- [64] Motakuri V. Ramana. An exact duality theory for semidefinite programming and its complexity implications. *Math. Programming*, 77(2, Ser. B):129–162, 1997. Semidefinite programming.
- [65] E. Rannou. The complexity of stratification computation. *Discrete Comput. Geom.*, 19(1):47–78, 1998.
- [66] J. Reif. Complexity of the mover’s problem and generalizations. In *IEEE Transactions on Robotics and Automation*, pages 421–427, 1979.
- [67] J. Renegar. On the computational complexity and geometry of the first-order theory of the reals. I-III. *J. Symbolic Comput.*, 13(3):255–352, 1992.
- [68] J. J. Rotman. *An Introduction to Algebraic Topology*. Springer-Verlag, 1988.
- [69] M.-F. Roy and A. Szpirglas. Complexity of the computations with real algebraic numbers. *Journal of Symbolic computation*, 10:39–51, 1990.
- [70] Mohab Safey El Din and Éric Schost. Polar varieties and computation of one point in each connected component of a smooth algebraic set. In *Proceedings of the 2003 International Symposium on Symbolic and Algebraic Computation*, pages 224–231 (electronic), New York, 2003. ACM.
- [71] Mohab Safey El Din and Éric Schost. Properness defects of projections and computation of at least one point in each connected component of a real algebraic set. *Discrete Comput. Geom.*, 32(3):417–430, 2004.
- [72] J. Schwartz and M. Sharir. On the piano movers’ problem ii. general techniques for computing topological properties of real algebraic manifolds. *Adv. Appl. Math.*, 4:298–351, 1983.
- [73] Sergey P. Tarasov and Mikhail N. Vyalyi. Semidefinite programming and arithmetic circuit evaluation. *Discrete Appl. Math.*, 156(11):2070–2078, 2008.
- [74] A. Tarski. *A decision method for elementary algebra and geometry*. University of California Press, Berkeley and Los Angeles, Calif., 1951. 2nd ed.
- [75] R. Thom. Sur l’homologie des variétés algébriques réelles. In *Differential and Combinatorial Topology (A Symposium in Honor of Marston Morse)*, pages 255–265. Princeton Univ. Press, Princeton, N.J., 1965.
- [76] S. Toda. PP is as hard as the polynomial-time hierarchy. *SIAM J. Comput.*, 20(5):865–877, 1991.
- [77] H. R. Wüthrich. Ein Entscheidungsverfahren für die Theorie der reell-abgeschlossenen Körper. *LNCS*, 43:138–162, 1976.

DEPARTMENT OF MATHEMATICS, PURDUE UNIVERSITY, WEST LAFAYETTE, IN 47907, U.S.A.  
 E-mail address: sbasu@math.purdue.edu



## TOPOLOGY OF REAL ALGEBRAIC VARIETIES; SOME RECENT RESULTS ON RATIONAL SURFACES

JOHANNES HUISMAN

*To Louis, Marie-Françoise, Michel,  
With gratitude*

*MSC 2000:* 14P25

*Keywords:* rational real algebraic surface, topological surface, rational model, algebraic diffeomorphism, automorphism group, continuous rational map, homotopy class, totally real cycle, reduced real Lawson homology

### 1. INTRODUCTION

The field of topology of real algebraic varieties is wide, active and many different techniques are employed. To write a survey on the subject forces one to make drastic choices. I chose to report on some recent work on rational real algebraic surfaces that I found enjoyable.

One of the aims of a survey is to make the subject more accessible to people working in other areas. I tried to present things in a most elementary way. However, some prerequisites are unavoidable like basic notions of algebraic geometry, topology and differential geometry.

I will conclude the paper with a section on two lines of research that seem promising, in my opinion.

Other topics concerning the topology of real algebraic varieties that I was not able to treat, but would have deserved to be treated, are, among others: cobordism classes of real algebraic varieties and morphisms [61, 42]<sup>1</sup>, cohomology of real algebraic varieties [67, 32, 34, 63, 33, 20], equivariant homotopy theory of spaces of real cycles [18, 62, 19], homotopy groups of real algebraic varieties [69],  $M$ -varieties [17, 39, 40], moduli of real stable maps [73, 74], Kollár's conjectures [28, 29, 12, 13], real algebraic cycles [8, 48, 49, 50, 9, 25, 55, 53, 70, 54], real algebraic models of smooth manifolds [47, 36, 10, 68, 1, 51, 52, 57], real algebraic surfaces [66, 58, 15, 76, 81, 11, 24, 16, 82, 59, 4, 65, 2], real cubic surfaces [26, 72, 3] three-folds [41, 43, 45] and four-folds [21, 44, 46, 22, 23]. I have left out here references concerning algorithms in real algebraic geometry, analytic geometry, enumerative real geometry, Hilbert's 16th problem, Klein surfaces and real algebraic curves, Nash manifolds, patch-working, real-root counting, semi-algebraic geometry and o-minimal structures, singularity theory, toric geometry, tropical geometry, and the B. and M. Shapiro conjecture. They will, most probably, be treated elsewhere in this volume, or during the conference.

---

<sup>1</sup>Here and further in this section, only references over the past 10 years are included

**Convention.** In this paper, a real algebraic variety can either be considered as a separated scheme over  $\mathbf{R}$  of finite type, or as a quasi-projective complex algebraic variety endowed with an antiholomorphic involution.

2. REAL RATIONAL SURFACES

Let  $X$  be an irreducible projective real algebraic surface. The surface  $X$  is *rational* if  $X$  admits a covering by open subsets  $U_1, \dots, U_n$ , each of which is isomorphic to the affine real algebraic plane  $\mathbf{A}^2$ .

We will be interested in the topological space  $X(\mathbf{R})$  of real points of a rational surface  $X$ . Here, the topology on  $X(\mathbf{R})$  is the euclidean topology, not the Zariski topology. It follows from our definition that  $X(\mathbf{R})$  is a compact connected topological surface. In fact,  $X(\mathbf{R})$  comes along with the structure of a smooth  $C^\infty$  surface.

**Examples 1.** 1. The real projective plane  $\mathbf{P}^2$  is rational. Indeed, the standard affine open subsets  $U_0, U_1, U_2$  defined by the inequalities  $x \neq 0$ ,  $y \neq 0$ ,  $z \neq 0$ , respectively, constitute a covering by open subsets, each of which is isomorphic to  $\mathbf{A}^2$ .

The set of real points  $\mathbf{P}^2(\mathbf{R})$  of  $\mathbf{P}^2$  is the topological real projective plane.

2. The real algebraic torus  $\mathbf{P}^1 \times \mathbf{P}^1$  is rational. Indeed, let  $U_0, U_1$  be the standard affine open subset of the real projective line  $\mathbf{P}^1$  defined by the inequalities  $x \neq 0$ ,  $y \neq 0$ , respectively. Then the subsets  $U_i \times U_j$ , for  $i, j = 0, 1$ , constitute a covering of  $\mathbf{P}^1 \times \mathbf{P}^1$  by open subsets, each of which is isomorphic to  $\mathbf{A}^2$ .

The set of real points  $(\mathbf{P}^1 \times \mathbf{P}^1)(\mathbf{R})$  of  $\mathbf{P}^1 \times \mathbf{P}^1$  is the topological torus  $S^1 \times S^1$ , where  $S^1$  denotes the unit circle in  $\mathbf{R}^2$ .

3. The real algebraic sphere  $\mathbf{S}^2$  in real projective space  $\mathbf{P}^3$  given by the affine equation  $x^2 + y^2 + z^2 = 1$  is rational. Indeed, for a real point  $P$  of  $\mathbf{S}^2$ , let  $T_P\mathbf{S}^2$  be the real projective plane in  $\mathbf{P}^3$  tangent to  $\mathbf{S}^2$  at  $P$ , and let  $\pi_P$  be the linear projection, or the stereographic projection, from  $\mathbf{S}^2 \setminus T_P\mathbf{S}^2$  into  $\mathbf{A}^2$ . The morphism  $\pi_P$  is an isomorphism of real algebraic varieties. Choose 3 distinct real points  $P_1, P_2, P_3$  of  $\mathbf{S}^2$ , and denote the open subset  $\mathbf{S}^2 \setminus T_{P_i}\mathbf{S}^2$  by  $U_i$ , for  $i = 1, 2, 3$ . Since the projective tangent planes at the points  $P_1, P_2, P_3$  intersect in 1 point only that, moreover, does not belong to  $\mathbf{S}^2$ , the subsets  $U_1, U_2, U_3$  constitute an open covering of  $\mathbf{S}^2$ . It follows that  $\mathbf{S}^2$  is rational.

The set of real points  $\mathbf{S}^2(\mathbf{R})$  of  $\mathbf{S}^2$  is the unit sphere  $S^2$  in  $\mathbf{R}^3$ .

*Remark 2.* The informed reader has noted that our definition of a rational surface is not the standard one. If  $X$  is a rational surface in our sense, then  $X$  contains a dense open subset isomorphic to  $\mathbf{A}^2$ , and therefore, its function field is isomorphic to the rational function field  $\mathbf{R}(x, y)$ . The converse is somewhat harder to prove. Since it is not essential for what we want to explain, we omit a proof.

Let us recall the explicit construction of the blow-up of  $\mathbf{A}^2$  at a real point  $P$ . For simplicity, we may assume that  $P$  is the origin  $O$ . Let  $x, y$  be the coordinates on  $\mathbf{A}^2$ . We need 2 further copies of  $\mathbf{A}^2$  that we will denote by  $\mathbf{A}_0^2$  and  $\mathbf{A}_1^2$  in order to distinguish them from each other. Denote by

$x_i, y_i$  the coordinate functions on  $\mathbf{A}_i^2$ , for  $i = 0, 1$ . Define two morphisms

$$\varphi_0: \mathbf{A}_0^2 \longrightarrow \mathbf{A}^2 \quad \text{and} \quad \varphi_1: \mathbf{A}_1^2 \longrightarrow \mathbf{A}^2$$

by

$$\varphi_0(x_0, y_0) = (x_0, x_0 y_0) \quad \text{and} \quad \varphi_1(x_1, y_1) = (x_1 y_1, y_1).$$

Geometrically, the morphism  $\varphi_0$  maps the horizontal lines  $y_0 = \text{cst}$  in  $\mathbf{A}_0^2$  to the nonvertical lines that pass through the origin in  $\mathbf{A}^2$ . Similarly,  $\varphi_1$  maps the vertical lines in  $\mathbf{A}_1^2$  to the nonhorizontal lines that pass through the origin in  $\mathbf{A}^2$ . In particular,  $\varphi_0$  maps the  $y_0$ -axis in  $\mathbf{A}_0^2$  onto the origin of  $\mathbf{A}^2$ , and  $\varphi_1$  maps the  $x_1$ -axis in  $\mathbf{A}_1^2$  onto the origin of  $\mathbf{A}^2$ .

Let  $U_0, U_1$  be the open subsets of  $\mathbf{A}^2$  defined by the inequalities  $x \neq 0, y \neq 0$ , respectively. The morphism  $\varphi_i$  is an isomorphism from  $\varphi_i^{-1}(U_i)$  onto  $U_i$ , for  $i = 0, 1$ . In particular, one gets an induced isomorphism  $\varphi_{10}$  from the open subset  $\varphi_0^{-1}(U_0 \cap U_1)$  of  $\mathbf{A}_0^2$  onto the open subset  $\varphi_1^{-1}(U_0 \cap U_1)$  of  $\mathbf{A}_1^2$ , and  $\varphi_{01}$  in the opposite direction. Explicitly,

$$\varphi_{10}(x_0, y_0) = \left(\frac{1}{y_0}, x_0 y_0\right) \quad \text{and} \quad \varphi_{01}(x_1, y_1) = \left(x_1 y_1, \frac{1}{x_1}\right).$$

These reciprocal isomorphisms extend to reciprocal isomorphisms between the open subset  $V_0$  of  $\mathbf{A}_0^2$  defined by the inequality  $y_0 \neq 0$  and the open subset  $V_1$  of  $\mathbf{A}_1^2$  defined by the inequality  $x_1 \neq 0$ . The blow-up  $B_O \mathbf{A}^2$  of  $\mathbf{A}^2$  at  $O$  is the real algebraic surface obtained by gluing  $\mathbf{A}_0^2$  and  $\mathbf{A}_1^2$  along their open subset  $V_0$  and  $V_1$  via the reciprocal isomorphisms  $\varphi_{10}$  and  $\varphi_{01}$ .

The morphisms  $\varphi_0$  and  $\varphi_1$  glue together to produce a morphism

$$\varphi: B_O \mathbf{A}^2 \longrightarrow \mathbf{A}^2.$$

It is an isomorphism over the open subset  $\mathbf{A}^2 \setminus \{O\}$ . We will, therefore, often identify  $\varphi^{-1}(\mathbf{A}^2 \setminus \{O\})$  with  $\mathbf{A}^2 \setminus \{O\}$ . The fiber  $\varphi^{-1}(O)$  is isomorphic to the real projective line  $\mathbf{P}^1$ , and is called the exceptional curve.

What is important for us here is that  $B_O \mathbf{A}^2$ , or more generally, the blow-up  $B_P \mathbf{A}^2$  of  $\mathbf{A}^2$  at a real point  $P$  admits an open covering by two affine subsets, both isomorphic to  $\mathbf{A}^2$ .

Let  $X$  be a rational surface. If  $P$  is a real point of  $X$ , then we can choose an open affine subset  $U$  of  $X$  containing  $P$  and isomorphic to  $\mathbf{A}^2$ , and define the blow-up of  $X$  at  $P$  to be the real algebraic surface obtained from  $X \setminus \{P\}$  and  $B_P U$  by gluing them along their common open subset  $U \setminus \{P\}$ . The price we have to pay for our down-to-earth treatment of the blow-up is that it is now not immediately clear that the blow-up of  $X$  at  $P$  does neither depend on the choice of  $U$ , nor on the choice of the isomorphism between  $U$  and  $\mathbf{A}^2$ . The sceptical reader is invited to consult any standard textbook on algebraic geometry of his liking to wipe away any persistent doubts. In any case, it is clear that the blow-up of a rational surface  $X$  at a real point is again rational. More generally:

**Proposition 3.** *Let  $X$  be a rational surface and let*

$$X_n \rightarrow X_{n-1} \rightarrow \cdots \rightarrow X_0 = X$$

*be a sequence of blow-ups at real points, starting with  $X$ . Then  $X_n$  is a rational surface.  $\square$*

If one wants to know what the set of real points of such a surface looks like, one has to get back to the construction of the blow-up of  $\mathbf{A}^2$  at the origin  $O$ . As observed above, the exceptional curve  $E$  in  $B_O\mathbf{A}^2$  is isomorphic to the real projective line  $\mathbf{P}^1$ . Therefore, its set of real points  $E(\mathbf{R})$  is, topologically speaking, a circle. It is also a smooth curve in the smooth surface  $(B_O\mathbf{A}^2)(\mathbf{R})$ . One can check that its normal bundle is not orientable, i.e., it is isomorphic to the Moebius bundle over  $E(\mathbf{R})$ . It follows that the set of real points  $(B_O\mathbf{A}^2)(\mathbf{R})$  of the blow-up of  $\mathbf{A}^2$  at  $O$  is homeomorphic to the connected sum  $\mathbf{R}^2\#\mathbf{P}^2(\mathbf{R})$  of the real affine plane  $\mathbf{R}^2$  with the real projective plane  $\mathbf{P}^2(\mathbf{R})$ .

It follows that, if  $X$  is a rational surface, then the set of real points  $(B_P X)(\mathbf{R})$  of the blow-up of  $X$  at a real point  $P$  is homeomorphic to the connected sum  $X(\mathbf{R})\#\mathbf{P}^2(\mathbf{R})$  of the set of real points  $X(\mathbf{R})$  of  $X$  with the real projective plane  $\mathbf{P}^2(\mathbf{R})$ .

From the classification of topological surfaces we know that for any nonorientable compact connected topological surface  $S$  there is a unique natural integer  $g$  such that  $S$  is homeomorphic to the connected sum of  $g + 1$  copies of the real projective plane  $\mathbf{P}^2(\mathbf{R})$ . The integer  $g$  will be called the genus of the surface  $S$ , e.g., the real projective plane  $\mathbf{P}^2(\mathbf{R})$  has genus 0, the Klein bottle  $\mathbf{P}^2(\mathbf{R})\#\mathbf{P}^2(\mathbf{R})$  has genus 1.

Let  $S$  be a compact connected topological surface. A rational surface  $X$  is a *rational algebraic model* for  $S$  if the set of real points  $X(\mathbf{R})$  of  $X$  is homeomorphic to  $S$ . The preceding observations and Examples 1.2 and 1.3 above lead to the following consequence:

**Corollary 4.** *Let  $S$  be compact connected topological surface. If  $S$  is nonorientable, or orientable and of genus 0 or 1, then  $S$  admits a rational algebraic model.* □

A deep result of Comessatti [14, p. 257] states that the other topological surfaces do not have any rational model:

**Theorem 5** (Comessatti). *Let  $X$  be a rational surface. Then  $X(\mathbf{R})$  is not homeomorphic to an orientable surface of genus greater than 1.* □

A modern proof uses the Minimal Model Program for real algebraic varieties as developed by Kollár [35, p. 206, Theorem 30]. In fact, that approach gives an even more precise statement.

Let  $S$  be a topological surface, and let  $X$  and  $Y$  be two rational models of  $S$ . We will say that  $X$  and  $Y$  are *isomorphic as rational models* if  $X(\mathbf{R})$  and  $Y(\mathbf{R})$  have isomorphic Zariski open neighborhoods in  $X$  and  $Y$ , respectively. Equivalently, the differentiable surfaces  $X(\mathbf{R})$  and  $Y(\mathbf{R})$  are algebraically diffeomorphic, i.e., there is a diffeomorphism  $f$  from  $X(\mathbf{R})$  into  $Y(\mathbf{R})$  whose coordinate functions are rational functions on  $X(\mathbf{R})$  without poles on  $X(\mathbf{R})$ , and the same holds for  $f^{-1}$ .

**Example 6.** Let  $P$  be a real point of the real algebraic sphere  $\mathbf{S}^2$ . Then the blow-up  $B_P\mathbf{S}^2$  of  $\mathbf{S}^2$  at  $P$  is a rational algebraic model of the topological real projective plane  $\mathbf{P}^2(\mathbf{R})$ . The algebraic real projective plane  $\mathbf{P}^2$  is a rational algebraic model of  $\mathbf{P}^2(\mathbf{R})$  as well. Although the real algebraic surfaces  $\mathbf{P}^2$  and  $B_P\mathbf{S}^2$  are not isomorphic, the stereographic projection induces

an algebraic diffeomorphism from  $(B_P\mathbf{S}^2)(\mathbf{R})$  onto  $\mathbf{P}^2(\mathbf{R})$ . The rational models  $B_P\mathbf{S}^2$  and  $\mathbf{P}^2$  are isomorphic rational models of the topological surface  $\mathbf{P}^2(\mathbf{R})$ .

Using Kollár’s Minimal Model Program one can prove the following statement (compare [5, Thm 3.1]):

**Theorem 7.** *Let  $S$  be a compact connected topological surface. Let  $X$  be a rational model of  $S$ .*

- (1) *If  $S$  is not orientable then  $X$  is isomorphic to a rational model of  $S$  obtained from  $\mathbf{S}^2$  by successively blowing up at real points only.*
- (2) *If  $S$  is orientable then  $X$  is isomorphic to  $\mathbf{S}^2$  or  $\mathbf{P}^1 \times \mathbf{P}^1$ , as a rational model. □*

This clearly implies Comessatti’s Theorem above, but it also opens the door to the classification of rational models of a given topological surface. Surprisingly enough, all rational models of a given topological surface turn out to be isomorphic as rational models [5, Thm 1.2]:

**Theorem 8.** *Let  $S$  be a compact connected topological surface. Then, any two rational algebraic models of  $S$  are isomorphic. □*

One of the crucial ingredients of the proof is the following. Let  $S$  be a nonorientable compact connected topological surface. According to Theorem 7, any rational model  $X$  of  $S$  is isomorphic to a rational model  $Y$  of  $S$  obtained from  $\mathbf{S}^2$  by successively blowing up real points. This means that there is a sequence of blow-ups at real points

$$Y = Y_n \rightarrow Y_{n-1} \rightarrow \cdots \rightarrow Y_0 = \mathbf{S}^2.$$

A difficulty arises when, for example,  $Y_2$  is the blow-up of  $Y_1$  at a real point  $P$  of the exceptional curve  $E$  of  $Y_1$ . One gets rid of this difficulty by using Example 6. Let us explain this in case  $n = 2$ , for simplicity. The algebraic surface  $Y_1$  is a rational model of  $\mathbf{P}^2(\mathbf{R})$ . Therefore,  $Y_1(\mathbf{R})$  is algebraically diffeomorphic to  $\mathbf{P}^2(\mathbf{R})$ . Moreover, there is such a diffeomorphism that maps the set of real points  $E(\mathbf{R})$  of the exceptional curve  $E$  to a real projective line of  $\mathbf{P}^2(\mathbf{R})$ . Now, all real projective lines in  $\mathbf{P}^2(\mathbf{R})$  are equal. Choose a real projective line  $D(\mathbf{R})$  of  $\mathbf{P}^2(\mathbf{R})$  that does not contain the point  $Q$  of  $\mathbf{P}^2(\mathbf{R})$  that corresponds to  $P$  under the diffeomorphism between  $Y_1(\mathbf{R})$  and  $\mathbf{P}^2(\mathbf{R})$ . Then there is a blow-up  $Y'_1$  of  $\mathbf{S}^2$  at a real point, and an algebraic diffeomorphism from  $Y'_1(\mathbf{R})$  onto  $\mathbf{P}^2(\mathbf{R})$  mapping the set of real points of the exceptional curve of  $Y'_1$  onto  $D(\mathbf{R})$ . Let  $P'$  be the real point of  $Y'_1$  that corresponds to  $Q$  under the diffeomorphism. Then,  $P'$  is not a real point of the exceptional curve of  $Y'_1$ . Since there is an algebraic diffeomorphism from  $Y_1(\mathbf{R})$  into  $Y'_1(\mathbf{R})$  that maps  $P$  onto  $P'$ , there is also an algebraic diffeomorphism from  $Y_2(\mathbf{R})$  into  $Y'_2(\mathbf{R})$ , the set of real points of the blow-up  $Y'_2$  of  $Y'_1$  at  $P'$ . Now,  $Y'_2$  is the blow-up of  $\mathbf{S}^2$  at 2 distinct real points, and is isomorphic as a rational model, to  $Y_2$ .

By an induction argument, one shows more generally that any rational model  $X$  of a nonorientable compact connected surface is isomorphic to a rational model  $Y$  obtained from  $\mathbf{S}^2$  by blowing up  $\mathbf{S}^2$  at a finite number of distinct real points. A proof of Theorem 8, different from the one in [5], can



then be obtained by showing that the group of algebraic self-diffeomorphisms of  $\mathbf{S}^2(\mathbf{R})$ , i.e., the standard unit sphere  $S^2$  in  $\mathbf{R}^3$ , is  $n$ -transitive, for each  $n$ . This approach has been followed in [30]. In fact, adapting the above induction argument, one can show even more [30, Thm 1.4]:

**Theorem 9.** *Let  $X$  be a rational surface. Then the group of algebraic self-diffeomorphisms  $\text{Diff}_{\text{alg}}(X(\mathbf{R}))$  of  $X(\mathbf{R})$  acts  $n$ -transitively on  $X(\mathbf{R})$ , for all natural integers  $n$ .  $\square$*

Recall that a group  $G$ , acting on a set  $S$ , acts  $n$ -transitively on  $S$  if for two  $n$ -tuples  $(P_1, \dots, P_n)$  and  $(Q_1, \dots, Q_n)$  of distinct elements of  $S$ , there is an element  $g \in G$  such that  $g \cdot P_i = Q_i$  for all  $i$ .

In the case when  $X$  is the real algebraic torus  $\mathbf{P}^1 \times \mathbf{P}^1$ , Theorem 9 was proved before [5, Thm 5.4]. In order to give an idea of the proof of Theorem 9, let us show how one can construct many algebraic self-diffeomorphisms of the unit sphere  $S^2$  in  $\mathbf{R}^3$  (cf. [30, Lemma 2.1]).

Let  $I$  be the interval  $[-1, 1]$  in  $\mathbf{R}$ . Choose any smooth algebraic map  $f$  from  $I$  into the circle  $S^1$ . This simply means that the two coordinate functions of  $f$  are real rational functions in one variable without poles in  $I$ . Define

$$\varphi_f: S^2 \longrightarrow S^2$$

by

$$\varphi_f(x, y, z) = (f(z) \cdot (x, y), z),$$

where  $\cdot$  denotes complex multiplication in  $\mathbf{R}^2 = \mathbf{C}$ . Then  $\varphi_f$  is an algebraic self-diffeomorphism of  $S^2$ . Indeed, its inverse is  $\varphi_{f^{-1}}$ , where  $f^{-1}$  maps  $z$  to the multiplicative inverse  $f(z)^{-1}$  of  $f(z)$ .

It is not difficult to prove, using the algebraic self-diffeomorphisms  $\varphi_f$  defined above, that the group of algebraic self-diffeomorphisms  $\text{Diff}_{\text{alg}}(S^2)$  of  $S^2$  acts  $n$ -transitively on  $S^2$ , for all natural integers  $n$ .

Theorem 9 remains valid if one considers the action of the group of algebraic self-diffeomorphisms on the set of real infinitely near points, or more precisely, real curvilinear subschemes of given length of a rational surface [31].

The question has been raised whether the group  $\text{Diff}_{\text{alg}}(X(\mathbf{R}))$  is dense in the group  $\text{Diff}(X(\mathbf{R}))$  of all self-diffeomorphisms of  $X(\mathbf{R})$ , for a rational surface  $X$ . This turns out to be true and has been proved by Kollár and Mangolte [37, Thm 4]:

**Theorem 10.** *Let  $X$  be a rational surface. Then the subgroup  $\text{Diff}_{\text{alg}}(X(\mathbf{R}))$  is dense in  $\text{Diff}(X(\mathbf{R}))$ .  $\square$*

In case when  $X$  is the real algebraic sphere  $\mathbf{S}^2$ , the proof uses a result of Lucackii to the effect that  $\text{SO}(3, 1)$  is a maximal closed subgroup of the neutral component  $\text{Diff}_0(S^2)$  of  $\text{Diff}(S^2)$ . It follows that  $\text{O}(3, 1)$  together with any nontrivial algebraic self-diffeomorphism of  $S^2$  of the form  $\varphi_f$  above, generate a dense subgroup of  $\text{Diff}(S^2)$ . A similar argument applies when  $X$  is the real algebraic torus.

Kollár and Mangolte then proceed by showing that the mapping class group

$$\mathcal{M}(X(\mathbf{R})) = \text{Diff}(X(\mathbf{R}))/\text{Diff}_0(X(\mathbf{R}))$$

can be generated by algebraic self-diffeomorphisms of  $X(\mathbf{R})$ , in case  $X$  is a rational surface [37, Thm 27]. These are the main ingredients of the proof of Theorem 10.

A closely related line of research studies generators of the group of algebraic self-diffeomorphisms of  $X(\mathbf{R})$ , for a rational surface  $X$ , and in fact mainly  $\mathbf{P}^2$  (see work of Ronga and Vust [75] and Blanc [unpublished]).

Blanc and Mangolte have studied transitivity of the group  $\text{Diff}_{\text{alg}}(X(\mathbf{R}))$  for a real algebraic surface  $X$  that is geometrically rational, i.e., its complexification  $X_{\mathbf{C}}$  is rational as a complex algebraic surface [6].

### 3. PROSPECTS

**Continuous rational maps.** In a recent paper, Kucharz introduces the notion of *continuous rational maps* between real algebraic varieties. More precisely, let  $X$  and  $Y$  be irreducible real algebraic varieties whose sets of real points are dense. A continuous rational map from  $X(\mathbf{R})$  into  $Y(\mathbf{R})$  is a rational map  $f$  from  $X$  into  $Y$  with the following property. Let  $U$  be the domain of the rational map  $f$ . The restriction of  $f$  to  $U(\mathbf{R})$  extends to a continuous map from  $X(\mathbf{R})$  into  $Y(\mathbf{R})$ .

A typical example of a continuous rational map is the rational function  $f = x^3/(x^2 + y^2)$  on  $\mathbf{A}^2$ . It defines a continuous rational map from  $\mathbf{R}^2$  into  $\mathbf{R}$  by defining  $f(0, 0) = 0$ . Such continuous rational functions have also been studied by Kollár very recently [38].

Let  $S^n$  be the unit sphere in  $\mathbf{R}^{n+1}$ . Several authors have studied different kinds of algebraic representatives of homotopy classes of continuous maps between spheres of different dimensions, without definite success [83, 7, 71]. Kucharz shows that all homotopy classes can be represented by continuous rational maps [56, Thm 1.1]:

**Theorem 11.** *Let  $n$  and  $p$  be nonzero natural integers. Any continuous map from  $S^n$  to  $S^p$  is homotopic to a continuous rational map.  $\square$*

In fact, the statement is more precise; one can impose arbitrary  $\mathcal{C}^r$ -regularity on the continuous rational map. In any case, Theorem 11 may open new ways of access to the ever mysterious homotopy groups of spheres.

Kucharz shows many other properties of continuous rational maps that give the feeling that this class of maps deserves to be studied more thoroughly. In fact, one should try to set up a theory of real algebraic varieties where affine subsets are allowed to be glued along continuous birational maps (work in progress of Mangolte, Monnier and the author). This would give rise to a concept of real algebraic varieties that is more flexible than the real algebraic varieties in the sense of [7], however still being finer than real birational geometry.

**Totally real cycles on, and reduced real Lawson homology of projective real algebraic varieties.** Let  $X$  be a projective real algebraic variety. A *totally real irreducible cycle* on  $X$  is an irreducible real algebraic subvariety  $Y$  of  $X$  whose set of real points  $Y(\mathbf{R})$  is dense in  $Y$ . Denote by  $Z_d(X)_{\text{tr}}$  the  $\mathbf{Z}/2$ -vector space freely generated by all totally real irreducible cycles on  $X$  of dimension  $d$ . It comes naturally equipped with the structure of a topological vector space. Since its elements can be represented

by reduced real algebraic cycles, the group  $Z_d(X)_{\text{tr}}$  is called, somewhat abusively, the group of *reduced real algebraic cycles* of dimension  $d$  on  $X$ .

The group  $Z_0(X)_{\text{tr}}$  of reduced real 0-cycles on  $X$  can be easily described. Let  $X(\mathbf{R})^{(i)}$  be the  $i$ -fold symmetric power of the set of real points  $X(\mathbf{R})$  of  $X$ , where  $i$  is a natural integer. The euclidean topology on  $X(\mathbf{R})$  induces a topology on  $X(\mathbf{R})^{(i)}$ . The disjoint union

$$\coprod_{i=0}^{\infty} X(\mathbf{R})^{(i)}$$

is then, in a natural way, a topological monoid mapping surjectively to  $Z_0(X)_{\text{tr}}$ . The topology of the latter is induced by that map.

The group  $Z_d(X)_{\text{tr}}$  has been introduced and studied in the Ph.D. Thesis of Lam [60]<sup>2</sup>. One of the results concerns the group  $Z_d(\mathbf{P}^n)_{\text{tr}}$  of reduced real algebraic cycles on the  $n$ -dimensional real projective space  $\mathbf{P}^n$ . The projective cone over a cycle defines an *algebraic suspension map*

$$\Sigma: Z_d(\mathbf{P}^n)_{\text{tr}} \longrightarrow Z_{d+1}(\mathbf{P}^{n+1})_{\text{tr}}$$

which is shown to be a homotopy equivalence.

Let  $X$  be a projective real algebraic variety. In a recent paper [80], Teh defines the real reduced Lawson  $(p, n)$ -th homology group of  $X$  as the  $(n-p)$ -th homotopy group of the topological space  $Z_p(X)_{\text{tr}}$ , i.e.

$$RL_p H_n(X) = \pi_{n-p}(Z_p(X)_{\text{tr}}),$$

where  $n$  and  $p$  are natural numbers satisfying  $p \leq n$ . In case  $p = 0$ , the Dold-Thom isomorphism gives rise to a natural isomorphism between the real reduced  $(0, n)$ -th homology group of  $X$  and the ordinary singular  $n$ -th homology group of  $X(\mathbf{R})$  with  $\mathbf{Z}/2$  coefficients. In case  $p > 0$ , the Dold-Thom isomorphism induces natural morphisms from the real reduced Lawson  $(p, n)$ -th homology group of  $X$  into the ordinary singular  $n$ -th homology group of  $X(\mathbf{R})$  with  $\mathbf{Z}/2$  coefficients [80, Prop 7.6]. Many other properties are derived. An interesting application can be found in [79], where Teh proves a generalization of the Harnack-Thom Inequality for real reduced Lawson homology groups (see [79, Thm 4.6]).

Another—seemingly disjoint—branch of real algebraic geometry also studies totally real cycles, in fact, totally real divisors [77, 27, 64, 78]. It makes one wonder whether cross-pollination between the two branches would give new insights into the topology and geometry of real algebraic varieties, in general, and rational real algebraic varieties, in particular.

#### REFERENCES

- [1] Akbulut, S.: Real algebraic structures. Proceedings of Gökova Geometry-Topology Conference 2005, 49–58, Gökova Geometry/Topology Conference (GGT), Gökova, 2006
- [2] Akriche, M., Mangolte, F.: Nombres de Betti des surfaces elliptiques réelles. Beitrage Algebra Geom. 49(1) (2008), 153–164
- [3] Allcock, D., Carlson, J. A., Toledo, D.: Hyperbolic geometry and moduli of real cubic surfaces. Ann. Sci. Éc. Norm. Supér. (4) 43(1) (2010), 69–115

<sup>2</sup>Since I do not have a copy of the Ph.D. Thesis of T.-K. Lam at my disposal, I do follow here [62]

- [4] Bihan, F., Mangolte, F.: Topological types and real regular Jacobian elliptic surfaces. *Geom. Dedicata* 127 (2007), 57–73
- [5] Biswas, I., Huisman, J.: Rational real algebraic models of topological surfaces. *Doc. Math.* 12 (2007), 549–567
- [6] Blanc, J., Mangolte, F.: Geometrically rational real conic bundles and very transitive actions. Preprint (2010), arXiv:0903.3101v4 [math.AG]
- [7] Bochnak, J., Coste, M., Roy, M.-F.: Real algebraic geometry, *Ergeb. Math. Grenzgeb.* (3), vol. 36, Springer-Verlag, 1998
- [8] Bochnak, J., Kucharz, W.: A topological proof of the Grothendieck formula in real algebraic geometry. *Enseign. Math.* (2) 48(3-4) (2002), 237–258
- [9] Bochnak, J., Kucharz, W.: Real algebraic morphisms represent few homotopy classes. *Math. Ann.* 337(4) (2007), 909–921
- [10] Calcut, J. S., King, H. C.: Noncompact codimension-1 real algebraic manifolds. *Michigan Math. J.* 52(2) (2004), 361–373
- [11] Catanese, F., Frediani, P.: Real hyperelliptic surfaces and the orbifold fundamental group. *J. Inst. Math. Jussieu* 2(2) (2003), 163–233
- [12] Catanese, F., Mangolte, F.: Real singular del Pezzo surfaces and 3-folds fibred by rational curves. I. *Michigan Math. J.* 56(2) (2008), 357–373
- [13] Catanese, F., Mangolte, F.: Real singular del Pezzo surfaces and 3-folds fibred by rational curves. II. *Ann. Sci. Éc. Norm. Supér.* (4) 42(4) (2009), 531–557
- [14] Comessatti, A.: Sulla connessione delle superficie razionali reali, *Annali di Math.* 23 (1914), 215–283.
- [15] Degtyarev, A., Kharlamov, V.: Real rational surfaces are quasi-simple. *J. Reine Angew. Math.* 551 (2002), 87–99
- [16] Degtyarev, A., Itenberg, I., Kharlamov, V.: Finiteness and quasi-simplicity for symmetric K3-surfaces. *Duke Math. J.* 122(1) (2004), 1–49
- [17] Derval, D.: Variétés Galois-maximales et éclatements. *Manuscripta Math.* 110(4) (2003), 467–474
- [18] dos Santos, P. F.: Algebraic cycles on real varieties and  $\mathbf{Z}/2$ -equivariant homotopy theory. *Proc. London Math. Soc.* (3) 86(2) (2003), 513–544
- [19] dos Santos, P. F., Lima-Filho, P.: Quaternionic algebraic cycles and reality. *Trans. Amer. Math. Soc.* 356(12) (2004), 4701–4736
- [20] dos Santos, P. F., Lima-Filho, P.: Bigraded equivariant cohomology of real quadrics. *Adv. Math.* 221(4) (2009), 1247–1280
- [21] Finashin, S., Kharlamov, V.: Deformation classes of real four-dimensional cubic hypersurfaces. *J. Algebraic Geom.* 17(4) (2008), 677–707
- [22] Finashin, S., Kharlamov, V.: On the deformation chirality of real cubic fourfolds. *Compos. Math.* 145(5) (2009), 1277–1304
- [23] Finashin, S., Kharlamov, V.: Topology of real cubic fourfolds. *J. Topol.* 3(1) (2010), 1–28
- [24] Frediani, P.: Real Kodaira surfaces. *Collect. Math.* 55(1) (2004), 61–96
- [25] Ghiloni, R.: Second order homological obstructions on real algebraic manifolds. *Topology Appl.* 154(17) (2007), 3090–3094
- [26] Holzer, S., Labs, O.: Illustrating the classification of real cubic surfaces. *Algebraic geometry and geometric modeling*, 119–134, *Math. Vis.*, Springer, Berlin, 2006
- [27] Huisman, J.: On the geometry of algebraic curves having many real components. *Rev. Mat. Complut.* 14(1) (2001), 83–92
- [28] Huisman, J., Mangolte, F.: Every orientable Seifert 3-manifold is a real component of a uniruled algebraic variety. *Topology* 44(1) (2005), 63–71
- [29] Huisman, J., Mangolte, F.: Every connected sum of lens spaces is a real component of a uniruled algebraic variety. *Ann. Inst. Fourier (Grenoble)* 55(7) (2005), 2475–2487
- [30] Huisman, J., Mangolte, F.: The group of automorphisms of a real rational surface is  $n$ -transitive. *Bull. London Math. Soc.* 41 (2009), 563–568
- [31] Huisman, J., Mangolte, F.: Automorphisms of real rational surfaces and weighted blow-up singularities. *Manuscripta Math.* 132(1-2) (2010), 1–17

- [32] Kalinin, I. O.: Cohomological characteristics of real algebraic manifolds. *Algebra i Analiz* 14(5) (2002), 39–72; translation in *St. Petersburg Math. J.* 14(5) (2003), 739–763
- [33] Kalinin, I. O.: On the cohomology of real algebraic varieties. *Zap. Nauchn. Sem. S.-Peterburg. Otdel. Mat. Inst. Steklov. (POMI)* 299 (2003), *Geom. i Topol.* 8, 112–151, 328–329; translation in *J. Math. Sci. (N. Y.)* 131(1) (2005), 5323–5344
- [34] Karoubi, M., Weibel, C.: Algebraic and Real K-theory of real varieties. *Topology* 42(4) (2003), 715–742
- [35] Kollár, J.: The topology of real algebraic varieties. *Current developments in mathematics 2000*, 197–231, Int. Press, Somerville, MA, 2001.
- [36] Kollár, J.: The Nash conjecture for nonprojective threefolds. *Symposium in Honor of C. H. Clemens (Salt Lake City, UT, 2000)*, 137–152, *Contemp. Math.*, 312, Amer. Math. Soc., Providence, RI, 2002
- [37] Kollár, J., Mangolte, F.: Cremona transformations and diffeomorphisms of surfaces. *Adv. Math.* 222(1) (2009), 44–61
- [38] Kollár, J.: Continuous rational functions on real and  $p$ -adic varieties. Preprint (2011), arXiv:1101.3737v1 [math.AG]
- [39] Krasnov, V. A.: Real algebraic maximal varieties. *Mat. Zametki* 73(6) (2003), 853–860; translation in *Math. Notes* 73(5-6) (2003), 806–812
- [40] Krasnov, V. A.: On the algebraic cohomology of real algebraic  $M$ -varieties. *Mat. Zametki* 76(6) (2004), 854–867; translation in *Math. Notes* 76(5-6) (2004), 796–809
- [41] Krasnov, V. A.: Rigid isotopy classification of real three-dimensional cubics. *Izv. Ross. Akad. Nauk Ser. Mat.* 70(4) (2006), 91–134; translation in *Izv. Math.* 70(4) (2006), 731–768
- [42] Krasnov, V. A.: Real algebraic manifolds and cobordisms. *Izv. Ross. Akad. Nauk Ser. Mat.* 71(3) (2007), 141–172; translation in *Izv. Math.* 71(3) (2007), 573–601
- [43] Krasnov, V. A.: The Albanese map of the Fano surface of a real cubic  $M$ -threefold. *Mat. Zametki* 84(3) (2008), 381–389; translation in *Mat. Zametki* 84(4) (2008), 356–362
- [44] Krasnov, V. A.: Equivariant topological classification of Fano varieties of real cubic fourfolds. *Mat. Zametki* 85(4) (2009), 603–615; translation in *Math. Notes* 85(3-4) (2009), 574–583
- [45] Krasnov, V. A.: On the topological classification of real three-dimensional cubics. *Mat. Zametki* 85(6) (2009), 886–893; translation in *Math. Notes* 85(5-6) (2009), 841–847
- [46] Krasnov, V. A.: On the Fano variety of a class of real four-dimensional cubics. *Mat. Zametki* 85(5) (2009), 711–720; translation in *Math. Notes* 85(5-6) (2009), 682–689
- [47] Kucharz, W.: Algebraic cycles and algebraic models of smooth manifolds. *J. Algebraic Geom.* 11(1) (2002), 101–127
- [48] Kucharz, W.: Real divisors algebraically equivalent to zero. *Math. Res. Lett.* 10(5-6) (2003), 807–818
- [49] Kucharz, W.: Algebraic equivalence of cycles and algebraic models of smooth manifolds. *Compos. Math.* 140(2) (2004), 501–510
- [50] Kucharz, W.: Rational and homological equivalence of real algebraic cycles. *Geom. Dedicata* 106 (2004), 113–122
- [51] Kucharz, W.: Submanifolds of real algebraic varieties. *Proc. Amer. Math. Soc.* 136(1) (2008), 55–60
- [52] Kucharz, W.: Curves on algebraic models of smooth manifolds. *Math. Res. Lett.* 15(2) (2008), 289–295
- [53] Kucharz, W.: Rational surfaces in algebraic models of smooth manifolds. *Arch. Math. (Basel)* 90(6) (2008), 572–578
- [54] Kucharz, W.: Splitting vector bundles by blowups. *Ann. Polon. Math.* 95(1) (2009), 95–101
- [55] Kucharz, W.: Cycles on algebraic models of smooth manifolds. *J. Eur. Math. Soc. (JEMS)* 11(2) (2009), 393–405
- [56] Kucharz, W.: Rational maps in real algebraic geometry. *Adv. Geom.* 9(4) (2009), 517–539

- [57] Kucharz, W.: Complex cycles on algebraic models of smooth manifolds. *Math. Ann.* 346(4) (2010), 829–856
- [58] Kulikov, V. S., Kharlamov, V. M.: On real structures on rigid surfaces. *Izv. Ross. Akad. Nauk Ser. Mat.* 66(1) (2002), 133–152; translation in *Izv. Math.* 66(1) (2002), 133–150
- [59] Kulikov, V. S., Kharlamov, V. M.: Surfaces with  $DIF \neq DEF$  real structures. *Izv. Ross. Akad. Nauk Ser. Mat.* 70(4) (2006), 135–174; translation in *Izv. Math.* 70(4) (2006), 769–807
- [60] Lam, T.-K.: Spaces of real algebraic cycles and homotopy theory, Ph.D. Thesis, SUNY, Stony Brook, 1990
- [61] Laszlo, Y., Viterbo, C.: Estimates of characteristic numbers of real algebraic varieties. *Topology* 45(2) (2006), 261–280
- [62] Lawson, H. B., Lima-Filho, P., Michelsohn, M.-L.: Algebraic cycles and the classical groups. I. Real cycles. *Topology* 42(2) (2003), 467–506
- [63] McCrory, C., Parusiński, A.: Virtual Betti numbers of real algebraic varieties. *C. R. Math. Acad. Sci. Paris* 336(9) (2003), 763–768
- [64] Monnier, J.-Ph.: Divisors on real curves. *Adv. Geom.* 3(3) (2003), 339–360
- [65] Nikulin, V. V.: On connected components of moduli of real polarized K3-surfaces. *Izv. Ross. Akad. Nauk Ser. Mat.* 72(1) (2008), 99–122; translation in *Izv. Math.* 72(1) (2008), 91–111
- [66] Ozan, Y.: On entire rational maps of real surfaces. *J. Korean Math. Soc.* 39(1) (2002), 77–89
- [67] Ozan, Y.: On algebraic K-theory of real algebraic varieties with circle action. *J. Pure Appl. Algebra* 170(2-3) (2002), 287–293
- [68] Ozan, Y.: Relative topology of real algebraic varieties in their complexifications. *Pacific J. Math.* 217(2) (2004), 291–302
- [69] Ozan, Y.: On homotopy groups of real algebraic varieties and their complexifications. *Geom. Dedicata* 108 (2004), 131–140
- [70] Öztürk, A.: Homology of real algebraic varieties and morphisms to spheres. *Proc. Amer. Math. Soc.* 137(2) (2009), 505–509
- [71] Peng, J., Tang, Z.: Algebraic maps from spheres to spheres. *Sci. China Ser. A* 42(11) (1999), 1147–1154
- [72] Polo-Blanco, I., Top, J.: Explicit real cubic surfaces. *Canad. Math. Bull.* 51(1) (2008), 125–133
- [73] Puignau, N.: Première classe de Stiefel-Whitney des espaces d’applications stables réelles en genre zéro vers une surface convexe. *J. Inst. Math. Jussieu* 8(2) (2009), 383–414
- [74] Puignau, N.: Sur la première classe de Stiefel-Whitney de l’espace des applications stables réelles vers l’espace projectif. *Ann. Inst. Fourier (Grenoble)* 60(1) (2010), 149–168
- [75] Ronga, F., Vust, T.: Birational diffeomorphisms of the real projective plane. *Comment. Math. Helv.* 80(3) (2005), 517–540
- [76] Russo, F.: The antibirational involutions of the plane and the classification of real del Pezzo surfaces. *Algebraic geometry*, 289–312, de Gruyter, Berlin, 2002
- [77] Scheiderer, C.: Sums of squares of regular functions on real algebraic varieties. *Trans. Amer. Math. Soc.* 352(3) (2000), 1039–1069
- [78] Scheiderer, C.: A Positivstellensatz for projective real varieties. Preprint (2011), arXiv:1104.1772v1 [math.AG]
- [79] Teh, J.-H.: Harnack-Thom theorem for higher cycle groups and Picard varieties. *Trans. Amer. Math. Soc.* 360(6) (2008), 3263–3285
- [80] Teh, J.-H.: A homology and cohomology theory for real projective varieties. *Indiana Univ. Math. J.* 59(1) (2010), 327–384
- [81] Welschinger, J.-Y.: Real structures on minimal ruled surfaces. *Comment. Math. Helv.* 78(2) (2003), 418–446
- [82] Welschinger, J.-Y.: Deformation classes of real ruled manifolds. *J. Reine Angew. Math.* 574 (2004), 103–120
- [83] Wood, R.: Polynomial maps from spheres to spheres. *Invent. Math.* 5 (1968) 163–168

(J. Huisman) UNIVERSITÉ EUROPÉENNE DE BRETAGNE, FRANCE

(J. Huisman) UNIVERSITÉ DE BREST; CNRS, UMR 6205 LABORATOIRE DE MATHÉMATIQUES  
DE BREST, ISSTB, 6, AVENUE VICTOR LE GORGEU, CS 93837, 29238 BREST CEDEX 3,  
FRANCE. TEL. +33 2 98 01 61 94, FAX +33 2 98 01 67 90

*E-mail address:* `johannes.huisman@univ-brest.fr`

*URL:* `http://pageperso.univ-brest.fr/~huisman`

**ANALYTIC ARCS AND REAL ANALYTIC SINGULARITIES**

KRZYSZTOF KURDYKA

*Dedicated to Marie-Françoise, Michel and Louis.*

CONTENTS

1. Introduction.	2
2. Virtual Betti numbers and the weight filtration	2
2.1. Arc-symmetric and $\mathcal{AS}$ -sets	2
2.2. Virtual Betti numbers	3
3. Blow-analytic equivalence and its invariants	4
3.1. Fukui's invariant	5
3.2. Motivic type invariants	5
3.3. Zeta functions	5
3.4. Blow-Nash equivalence and zeta functions	6
3.5. Blow-analytic equivalence for two variable germs	7
4. Arc-analyticity versus blow-analyticity	8
4.1. Algebraic case	9
5. Lipschitz properties of arc- and blow- analytic functions	9
5.1. Lipschitz arc- and blow-analytic homeomorphisms.	9
6. Analytic families of symmetric matrices	10
6.1. Desingularization of hyperbolic polynomials and analytic families	11
References	11



## 1. INTRODUCTION.

The goal of this survey is to present some aspects of the recent progress in the theory of real analytic singularities with particular emphasis on the use of analytic arcs and the structure of the spaces of such arcs.

The famous Curve Selecting Lemma of Bruhat-Cartan-Wallace has appeared already in the 50's of the last century and later was made by S. Łojasiewicz one of the most powerful methods in the real analytic geometry. The idea of studying the structure of the space of germs of analytic or formal arcs on singular complex varieties appeared in a preprint of J.F. Nash (1965), which was published 30 years later [29]. The motivation of J. F. Nash was to understand the resolution of singularities of H. Hironaka or possibly to give an alternative approach to this fundamental problem.

In the 70's T.C. Kuo introduced a notion of blow-analytic map, and suggested that the blow-analytic equivalence of an analytic family of real analytic function germs has no moduli [20]. Given real analytic manifolds  $M, N$ , he called a mapping  $f : M \rightarrow N$  *blow-analytic* if there exists  $\sigma : \tilde{M} \rightarrow M$  a locally finite composition of blowing-ups with smooth centers such that  $f \circ \sigma$  is analytic.

In the 80's a notion of arc-analytic function was introduced by the author [21]. Let  $M, N$  be real analytic manifolds, a function  $f : M \rightarrow N$  is called *arc-analytic* if  $f \circ \gamma$  is analytic for every analytic arc  $\gamma$ . Clearly each blow-analytic map is arc-analytic (and subanalytic). In the semialgebraic setting the inverse was established by E. Bierstone and P.D. Milman [2], and also by A. Parusiński [31]. However in the general analytic case the question whether every subanalytic and arc-analytic function is blow-analytic remains a challenging open problem. I will discuss this issue in the survey.

In the late 90's M. Kontsevich brought new ideas of the motivic measure to study the structure of the space of analytic (or formal) arcs. This sparkling idea was developed in a spectacular way by J. Denef and F. Loeser [5]. This was an important breakthrough which has numerous applications in algebraic geometry and singularity theory. It turns out to be also surprisingly useful and applicable in the real context. I will describe in this survey some important results obtained using motivic integration in the real analytic case. In January 2003 a *Winter School Real Algebraic and Analytic Geometry & Motivic Integration* was held in Aussois. The goal was to introduce motivic integration methods to the community of real algebraic and analytic geometers. Looking back from the eight-year perspective, I am convinced that it was a successful investment.

## 2. VIRTUAL BETTI NUMBERS AND THE WEIGHT FILTRATION

First I will recall some relevant notions.

**2.1. Arc-symmetric and  $\mathcal{AS}$ -sets.** Let  $M$  be a real analytic manifold, we say that  $E \subset M$  is *arc-symmetric in  $M$*  (cf. [21]), if it satisfies the following test: given an analytic arc  $\gamma : (-1, 1) \rightarrow M$ , then either  $\gamma^{-1}(E)$  consists of isolated points

or  $\gamma(-1, 1) \subset E$ . Arc-symmetric semialgebraic subsets of an affine space form a family which contains all connected (even analytic) components of real algebraic sets. Taking the sets of this family as closed sets we define a topology  $\mathcal{AR}$  on  $\mathbb{R}^n$ . This topology is actually noetherian, and stronger than the Zariski topology. Moreover the  $\mathcal{AR}$ -irreducible components are connected (and closed) for the strong topology. So, to some extent, the  $\mathcal{AR}$  topology is similar to the Zariski topology in the complex case and it is well known how powerful are topological methods in the complex case.

In the sequel we will be mostly interested in the case where  $M = \mathbb{R}^n$  and  $E$  is semialgebraic. So by an arc-symmetric set we will mean a semialgebraic arc-symmetric set unless otherwise stated.

The local topological properties of arc-symmetric sets are presented in [22]. We have used the technique of the Euler integral of constructible functions, in a similar way as for the real algebraic sets as explained in [4]. In particular we have proved that the arc-symmetric sets satisfy the same local topological properties as the real algebraic ones, they are (mod 2) Euler spaces, for instance. This similarity is more transparent if we restrict ourselves to the compact arc-symmetric sets or, in general, to the finite set-theoretic combinations of compact arc-symmetric sets, called the  $\mathcal{AS}$ -sets.

Precisely  $\mathcal{AS}$  subsets of  $\mathbb{R}^n$ , considered by A. Parusiński in [32], are the traces on  $\mathbb{R}^n$  of finite set-theoretic combinations of arc-symmetric subsets in  $\mathbb{P}^n$ . For such sets we do not need the properness assumption to show that the image of an  $\mathcal{AS}$ -set by an injective map with an  $\mathcal{AS}$  graph is again an  $\mathcal{AS}$ -set.

**2.2. Virtual Betti numbers.** Recently the arc-symmetric sets appeared as well in the construction of new invariants in real singularity theory. Recall that for a real algebraic set  $X$  new additive invariants, called the *virtual Betti numbers*  $\beta_i(X)$  have been introduced independently by Totaro [39], McCrory and Parusiński [27], see also Pennaneac'h [35]. These invariants coincide with the standard Betti numbers for  $X$  compact and nonsingular, that is  $\beta_i(X) = \dim H_k(X, \mathbb{Z}_2)$ . But in the singular case they distinguish fine analytic structure of a set. For instance, two compact curves which look like a figure eight

$$X = \{(x, y) : y^2 = x^2 - x^4\}$$

and another one which is a union of two circles with one common point

$$Y = \{(x, y) : ((x + 1)^2 + y^2 - 1)((x - 1)^2 + y^2 - 1) = 0\}$$

are homeomorphic, but  $\beta_1(X) = 1$  and  $\beta_1(Y) = 2$ . So virtual Betti numbers are not topological invariants, but they are invariants of bijections with algebraically constructible graphs. (A set is called *algebraically constructible* if it is a finite union of differences of algebraic sets.)

These invariants have been extended to the  $\mathcal{AS}$ -sets by G. Fichou in [6]. So in fact virtual Betti numbers are invariants of bijections with a graph which is an  $\mathcal{AS}$

set. As in the classical way one defines a *virtual Poincaré polynomial* of  $X \subset \mathbb{R}^n$  which is an  $\mathcal{AS}$  set by the formula

$$\beta(X, u) = \sum_{i=0}^d \beta_i(X)u^i,$$

where  $d = \dim X$ . Note that  $\beta_i(X) = 0$  for  $i > d$ . We have:  $\beta(\emptyset) = 0$ ,  $\beta(\mathbb{P}^n) = 1 + u + u^2 + \dots + u^n$ ,  $\beta(\mathbf{R}^n) = u^n$ . So  $\beta : \mathcal{AS} \rightarrow \mathbb{Z}[u]$  is a map with the following properties

- $\beta(X) = b(X)$  is a standard Poincaré polynomial for  $X$  nonsingular and compact.
- $\beta(X) = \beta(X - Y) + \beta(Y)$  if  $Y$  is a closed subset in  $X$ .
- $\beta(X \times Y) = \beta(X)\beta(Y)$ .

Using the  $\mathcal{AS}$ -sets C. McCrory and A. Parusiński associate in [28] to each real algebraic variety (or more generally to each locally compact  $\mathcal{AS}$ -set) a filtered chain complex, which induces on Borel-Moore homology with  $\mathbb{Z}_2$  coefficients an analog of the weight filtration for complex algebraic varieties. This filtered complex is functorial with respect to proper maps with  $\mathcal{AS}$  graphs, so in particular, with respect to regular or Nash (semialgebraic and analytic) proper morphisms. The virtual Betti numbers can be computed from the spectral sequence associated to this filtration. As McCrory and Parusiński show the virtual Betti numbers are the only additive invariants of real algebraic varieties that do not distinguish Nash isomorphic compact varieties (all the others invariants are combinations of virtual Betti numbers).

We call  $\chi_c(X) := \beta(X, -1)$  a *virtual Euler characteristic* of  $X$ . The additivity of these invariants allows one to construct new invariants of the germs of real analytic functions, analogous to the zeta function of Denef and Loeser. This will be discussed in the next sections.

### 3. BLOW-ANALYTIC EQUIVALENCE AND ITS INVARIANTS

One of the fundamental questions in the classification of germs of analytic functions is finding a "good" definition of their equivalence. Assume that we are given two germs  $f, g : (\mathbb{R}^n, 0) \rightarrow (\mathbb{R}, 0)$  of analytic functions, we would like to say that they are *equivalent* if there exists the germ of a homeomorphism  $h : (\mathbb{R}^n, 0) \rightarrow (\mathbb{R}^n, 0)$  such that  $f = g \circ h$ . But this equivalence is too coarse i.e naturally distinct germs like  $f(x, y) = x$  and  $g(x, y) = x^3 - y^2$  are equivalent. So we would like to put some restrictions on homeomorphism  $h$ , for instance that  $h$  is a  $C^k$  diffeomorphism,  $k \geq 1$ . However with this definition we obtain too fine equivalence relation in the sense that there are analytic families of analytic germs in finitely many parameters such that every two germs are not  $C^1$  equivalent. In the classical example of Whitney, the zeros of the family  $f_t(x, y) = xy(x + y)(x - ty)$ ,  $t \in (-1, 1)$  form a 1-parameter family of 4 lines with non-constant cross-ratio. So  $t \neq s$  implies that  $f_t$  is not  $C^1$  equivalent to  $f_s$ .

An idea of T.C. Kuo was to consider the equivalence relation defined by the family of *blow-analytic homeomorphisms*. Actually he proved in [20] that the blow-analytic equivalence of an analytic family of real analytic function germs with isolated singularities has no moduli.

The most general definition of *blow-analytic equivalence* of two germs of analytic functions  $f, g : (\mathbb{R}^n, 0) \rightarrow (\mathbb{R}, 0)$  is as follows: there exists the germ of a homeomorphism  $h : (\mathbb{R}^n, 0) \rightarrow (\mathbb{R}^n, 0)$  such that  $f = g \circ h$ , moreover  $h$  and  $h^{-1}$  are blow-analytic. However with this definition the theory is rather at the very beginning. In the sequel several more restrictive definitions of blow-analytic equivalence shall be used.

**3.1. Fukui's invariant.** Let me recall  $\mathcal{F}(f)$  the *invariant of Fukui* [11] associated to the germ of an analytic function  $f : (\mathbb{R}^n, 0) \rightarrow (\mathbb{R}, 0)$ .  $\mathcal{F}(f)$  is a subset of  $\mathbb{N}$  which consists of those  $k$  for which there exists the germ of an analytic arc  $\gamma : (\mathbb{R}, 0) \rightarrow (\mathbb{R}^n, 0)$  such that the order of  $f \circ \gamma$  at 0 is equal to  $k$ . It is quite straightforward to check that if  $f$  and  $g$  are blow-equivalent then  $\mathcal{F}(f) = \mathcal{F}(g)$ . Indeed if  $h$  and  $h^{-1}$  are blow-analytic then they preserve analytic arcs. More precisely, if we denote by  $\mathcal{L}$  the space of germs of analytic arcs  $\gamma : (\mathbb{R}, 0) \rightarrow (\mathbb{R}^n, 0)$ , then the mapping

$$h^* : \mathcal{L} \ni \gamma \mapsto h \circ \gamma \in \mathcal{L}$$

is a bijection if and only  $h$  and  $h^{-1}$  are arc-analytic. In particular, if  $h$  and  $h^{-1}$  are blow-analytic, then  $h^*$  is a bijection. Recent progress in the study of Fukui's invariant can be found in [15].

**3.2. Motivic type invariants.** More fine invariants of a blow-analytic equivalence were constructed following the idea of J. Nash of truncation of arcs and motivic type constructions of J. Denef and F. Loeser. We start with notations: let

$$L_k := \{\alpha : (\mathbb{R}, 0) \rightarrow (\mathbb{R}^n, 0) : \text{polynomial of degree at most } k\} = \mathbb{R}^{kn}.$$

Let  $f : (\mathbb{R}^n, 0) \rightarrow (\mathbb{R}, 0)$  be the germ of an analytic function. The following spaces are algebraically constructible

$$A_k(f) := \{\alpha \in L_k : \text{ord}(f \circ \alpha) = k\} \quad A_k^\pm(f) := \{\alpha \in L_k : f \circ \alpha = \pm t^k + \dots\}$$

We remark that if  $f$  and  $g$  are analytically equivalent (i.e  $f = g \circ h$  with  $h$  the germ of an analytic diffeomorphism), then  $A_k(f) \sim A_k(g)$ ,  $A_k^\pm(f) \sim A_k^\pm(g)$ . (Here  $\sim$  means isomorphism of algebraically constructible sets.) Hence, not only they have the same Poincaré polynomials, but also the same virtual Poincaré polynomials.

**3.3. Zeta functions.** S. Koike and A. Parusiński [17] defined zeta functions of a germ  $f$  by the following formulas:

$$Z_f(t) := \sum_{k \geq 1} \chi^c(A_k(f)) t^k \quad Z_f^\pm(t) := \sum_{k \geq 1} \chi^c(A_k^\pm(f)) t^k$$

where  $\chi^c(\cdot)$  is the  $\mathbb{Z}_2$ -Euler characteristic with compact supports. They proved that  $Z_f(t) = Z_g(t)$  and  $Z_f^\pm(t) = Z_g^\pm(t)$  provided that the germs  $f, g$  are blow-analytically

equivalent in the following sense:  $f = g \circ h$ , for some  $h$  such that the following diagram is commutative

$$\begin{CD} (M_f, \sigma_f^{-1}(0)) @>H>> (M_g, \sigma_g^{-1}(0)) \\ @V\sigma_fVV @VV\sigma_gV \\ (\mathbb{R}^n, 0) @>h>> (\mathbb{R}^n, 0) \end{CD}$$

where  $\sigma_f, \sigma_g$  are real analytic modifications which are isomorphisms over complements of  $f^{-1}(0)$  and  $g^{-1}(0)$ ,  $M_f, M_g$  are smooth analytic manifolds and  $H$  is an analytic diffeomorphism. Then consequently  $h$  is a homeomorphism and  $h, h^{-1}$  are blow-analytic. Note that it is an open question whether this relation is transitive. S. Koike and A. Parusiński also prove the Thom-Sebastiani formula for these zeta functions, which expresses the zeta functions for the function  $f(x) + g(y)$  in terms of the zeta functions of  $f(x)$  and  $g(y)$ . They also investigated the zeta functions for Brieskorn polynomials in two and three variables. They found that the zeta functions of the Brieskorn polynomials  $x^p + y^{kp} + z^{kp}$ , where  $p$  is an even number, do not depend on  $k$ . This means that we still do not know whether they are blow-analytically equivalent or not.

**3.4. Blow-Nash equivalence and zeta functions.** G. Fichou [6] has considerably extended this approach taking into account the virtual Poincaré polynomials of the sets  $A_k^\pm(f)$ . Given two germs of Nash functions (i.e analytic and semialgebraic)  $f, g : (\mathbb{R}^n, 0) \rightarrow (\mathbb{R}, 0)$  we say that they are *blow-Nash equivalent* if  $f = g \circ h$  for some  $h$  such that the following diagram is commutative

$$\begin{CD} (M_f, \sigma_f^{-1}(0)) @>H>> (M_g, \sigma_g^{-1}(0)) \\ @V\sigma_fVV @VV\sigma_gV \\ (\mathbb{R}^n, 0) @>h>> (\mathbb{R}^n, 0) \end{CD}$$

where  $\sigma_f, \sigma_g$  are proper birational morphisms which are isomorphisms over complements of  $f^{-1}(0)$  and  $g^{-1}(0)$ ;  $M_f, M_g$  are open neighborhoods of  $\sigma_f^{-1}(0), \sigma_g^{-1}(0)$  and  $H$  is a Nash diffeomorphism. Then consequently  $h$  is a homeomorphism and  $h, h^{-1}$  are *blow-Nash*. In fact he assumed even more, namely that  $f \circ \sigma_f$  and  $jac \sigma_f$  (respectively  $f \circ \sigma_g$  and  $jac \sigma_g$ ) are normal crossings. (Again it is an open question whether this relation is transitive).

Then he defined zeta functions as follows

$$Z_f(t) := \sum_{k \geq 1} \beta(A_k(f)) \left(\frac{t}{u^n}\right)^k \quad Z_f^\pm(t) := \sum_{k \geq 1} \beta(A_k^\pm(f)) \left(\frac{t}{u^n}\right)^k$$

where  $\beta$  is the virtual Poincaré polynomial. G. Fichou proved that  $Z_f(t) = Z_g(t)$  and  $Z_f^\pm(t) = Z_g^\pm(t)$  if  $f, g$  are blow-Nash equivalent. He obtained the classification of two-variable Brieskorn polynomials under blow-Nash equivalence. He answered also the question of the non-existence of moduli for blow-Nash equivalence in the

case of an algebraic family with isolated singularities. Applying this approach G. Fichou has obtained several interesting results on blow-Nash equivalence and virtual Betti numbers [7, 8, 9, 10].

**3.5. Blow-analytic equivalence for two variable germs.** Koike and Parusiński [18] obtained complete blow analytic classification of germs of analytic functions in two variables. The authors use the blow-analytic equivalence of  $f, g$  in the sense Subsection 3.3 , namely that  $f = g \circ h$  and the following diagram is commutative

$$\begin{array}{ccc} (M_f, \sigma_f^{-1}(0)) & \xrightarrow{H} & (M_g, \sigma_g^{-1}(0)) \\ \sigma_f \downarrow & & \downarrow \sigma_g \\ (\mathbb{R}^n, 0) & \xrightarrow{h} & (\mathbb{R}^n, 0) \end{array}$$

where  $\sigma_f, \sigma_g$  are real analytic modifications which are isomorphisms over complements of  $f^{-1}(0)$  and  $g^{-1}(0)$ ,  $M_f, M_g$  are smooth analytic manifolds and  $H$  is an analytic diffeomorphism. In fact, as they prove, this definition is equivalent (in 2 dimensional case) to *cascade blow-analytic equivalence* which means the following:  $\sigma_f, \sigma_g$  are the composition of the same number of point blow-ups  $\sigma_f = \sigma_1 \circ \dots \circ \sigma_n$ ,  $\sigma_g = \tau_1 \circ \dots \circ \tau_n$ . Moreover on each level of the tower there is a homeomorphism  $h_i$  such that

$$h_i \circ (\sigma_i \circ \dots \circ \sigma_n) = \tau_i \circ \dots \circ \tau_n,$$

for  $i = 0, \dots, n - 1$ , where  $h_0 = h$ . With this definition it is much easier to work, for instance the transitivity is proved.

As shown in [18] for two variable real analytic function germs the blow-analytic equivalence is a natural counterpart of topological equivalence of complex analytic germs. Recall that, by an old result of Zariski, the topological type of a plane curve singularity  $(X, 0) \subset (\mathbb{C}^2, 0)$  is determined by the Puiseux pairs of each irreducible component and the intersection numbers of any pairs of distinct components. It can be shown, cf. [33], that the topological type of function germs  $f : (\mathbb{C}^2, 0) \rightarrow (\mathbb{C}, 0)$  is completely characterized, also in the non-reduced case  $f = \prod f_i^{d_i}$ , by the embedded topological type of its zero set and the multiplicities  $d_i$  of its irreducible components.

As shown in [18] the two variable blow-analytic equivalence classes are classified by multiplicities of irreducible components, their mutual intersection numbers, and real analytic versions of Puiseux pairs. The precise result says

**Theorem 3.1.** *Let  $f : (\mathbb{R}^2, 0) \rightarrow (\mathbb{R}, 0)$  and  $g : (\mathbb{R}^2, 0) \rightarrow (\mathbb{R}, 0)$  be real analytic function germs. Then the following conditions are equivalent:*

- (1)  *$f$  and  $g$  are blow-analytically equivalent.*
- (2)  *$f$  and  $g$  have isomorphic minimal resolutions.*
- (3) *The real tree models of  $f$  and  $g$  are isomorphic.*

We refer to [18] for a precise definition of the real tree model, a combinatorial invariant that encodes the Puiseux pairs in particular (a version of the real tree model was used in [24] to study Lipschitz properties of some arc-analytic functions).

Theorem 3.1 gives that blow-analytically equivalent weighted homogeneous isolated singularities  $f : (\mathbb{R}^2, 0) \rightarrow (\mathbb{R}, 0)$  and  $g : (\mathbb{R}^2, 0) \rightarrow (\mathbb{R}, 0)$  are either both analytically equivalent to  $xy$  or they have the same weights, the result obtained first by Abderrahmane [1]. Theorem 3.1 gives also the blow-analytic classification of Brieskorn two variable singularities  $\pm x^p \pm y^q$ . In another example given in [18], it is shown that  $f(x, y) = x(x^3 - y^5)(x^3 + y^5)$  and  $g(x, y) = x(x^3 - y^5)(x^3 - 2y^5)$  have the same Fukui invariants and zeta functions but they are not blow-analytically equivalent.

The two dimensional case is very special and sometimes surprising. Using the Newton polygon method it is shown in [19] that  $C^1$  equivalent germs  $f : (\mathbb{R}^2, 0) \rightarrow (\mathbb{R}, 0)$  and  $g : (\mathbb{R}^2, 0) \rightarrow (\mathbb{R}, 0)$  are blow-analytically equivalent, in particular the corresponding components of their zero sets have the same Puiseux pairs. This is not longer true if one replaces  $C^1$  with bi-Lipschitz equivalence, cf. [19] Example 4.3.

#### 4. ARC-ANALYTICITY VERSUS BLOW-ANALYTICITY

One of the intriguing questions in the real analytic singularity theory is the following: assume that  $M$  is a compact analytic manifold and  $f : M \rightarrow \mathbb{R}$  is an arc-analytic and subanalytic function, does there exist  $\pi : \tilde{M} \rightarrow M$  a finite composition of blowing-ups with smooth and closed centers such that  $f \circ \pi$  is analytic (i.e. that  $f$  is blow-analytic) ?

By E. Bierstone and P.D. Milman [2], see also A. Parusiński [31], the answer is positive if  $f$  satisfies an equation  $G(x, f(x)) = 0$ , where  $G(x, y) = \sum_{i=0}^p g_i(x)y^{p-i}$  with  $g_i : M \rightarrow \mathbb{R}$  analytic. In the case  $\dim M = 2$ , the answer is always positive (without any extra assumption). However the proof is not trivial and essentially uses results of [2] or [31] and the fact that the centers are points so they are naturally closed.

Probably the answer (if positive) in the general case would require a better understanding of flattening of real analytic mappings and a more geometric understanding of the resolution of singularities. Some progress towards the solution of this problem was made by K. Kurdyka and A. Parusiński [23].

For an arc-analytic subanalytic function  $f : M \rightarrow \mathbb{R}$  denote by  $S(f)$  the set of non-analyticity of  $f$ . By definition,  $S(f)$  is the complement of the set  $R(f)$  of points  $p \in M$ , such that  $f$  is analytic at  $p$ . It is known that  $S(f)$  is closed, subanalytic and  $\dim S(f) \leq \dim M - 2$ . We proved in [23] that the set  $S(f)$  is actually arc-analytic. Note that, this is a necessary condition for the positive answer to the question stated in the beginning of this section. The second main theorem of that paper is a refinement of the main result of [2].

**Theorem 4.1.** *Let  $M$  be a real analytic manifold and let  $f : M \rightarrow \mathbb{R}$  be an arc-analytic function. Suppose that  $G(x, f(x)) = 0$ , where  $G(x, y) = \sum_{i=0}^p g_i(x)y^{p-i}$  is a nonzero polynomial in  $y$  with coefficients  $g_i$  which are analytic functions on  $M$ . Then there is a mapping  $\pi : M' \rightarrow M$ , which is a composite of a finite sequence of*

blowing-ups with nonsingular closed centers over any relatively compact open subset of  $M$ , such that

- (1)  $f \circ \pi$  is analytic.
- (2) over any open relatively compact subset of  $M$ ,  $\pi$  is a composite of a finite sequence of blowing-ups with nonsingular closed centers :  $\pi = \pi_0 \circ \dots \circ \pi_k$ , and for every  $j = 0, \dots, k$  the center of  $\pi_j$  is contained in the locus of non-analyticity of  $f \circ \pi_0 \circ \dots \circ \pi_{j-1}$ .

In particular,  $\pi$  is an isomorphism over the set of analyticity of  $f$ .

This theorem holds in the Nash category with  $\pi$  actually a finite composite of a sequence of blowings-up with nonsingular Nash closed centers.

**4.1. Algebraic case.** Theorem 4.1 can be stated in the real algebraic version, see [2]. In this case if we assume that  $X$  is a nonsingular real algebraic variety and that the coefficients  $g_i$  are regular, then we may require that  $\pi$  is a finite composite of blowing-ups with nonsingular algebraic centers. However we cannot require that the centers of blowing-ups are entirely contained in the non-analyticity loci as Example 1.6 [23] shows.

### 5. LIPSCHITZ PROPERTIES OF ARC- AND BLOW- ANALYTIC FUNCTIONS

Arc-analytic (and subanalytic) function need not be locally Lipschitz. The first explicit example was given by L. Paunescu [34], namely  $f(x, y) = \frac{xy^5}{x^4+y^6}$ ,  $f(0, 0) = 0$ .

K. Kurdyka and L. Paunescu [24] proved that, if  $h$  is arc-analytic and  $h^r$  is analytic for some integer  $r$ , then  $h : (\mathbb{R}^n, 0) \rightarrow (\mathbb{R}, 0)$  is Lipschitz. The method of the proof is based on the reduction to the two dimensional case and a thorough investigation of the real tree model mentioned in the previous section. However, in general, arc-analytic roots of polynomials with analytic coefficients may not be Lipschitz.

*Example 5.1.* Consider a polynomial  $P(x, y, z) = (z^4 - (x^2 + y^8))^2 - x^4 - y^{20}$ . It has an arc-analytic (blow-analytic) root

$$f = \sqrt[4]{x^2 + y^8 - \sqrt{x^4 + y^{20}}}$$

which is not lipschitz! Note that the above polynomial is not hyperbolic (we will explain this in the next section).

**5.1. Lipschitz arc- and blow-analytic homeomorphisms.** Surprisingly, several analogues of the analytic Inverse Mapping Theorem are true for arc- or blow-analytic homeomorphisms, when a Lipschitz property is satisfied. First T. Fukui, K. Kurdyka and L. Paunescu [13] proved the following.

**Theorem 5.2.** *Let  $f : (\mathbb{R}^n, 0) \rightarrow (\mathbb{R}^n, 0)$  be the germ of a subanalytic homeomorphism which is bi-Lipschitz and arc-analytic. Then  $f^{-1}$  is also arc-analytic.*



In the case of blow-analytic semialgebraic homeomorphism a stronger result is true. Namely, T. Fukui, K. Kurdyka, A. Parusiński [14] using motivic type arguments have proved the following theorem.

**Theorem 5.3.** *Let  $f : (\mathbb{R}^n, 0) \rightarrow (\mathbb{R}^n, 0)$  be a semialgebraic homeomorphism such that  $f$  is Lipschitz and  $f^{-1}$  is blow-analytic. Then  $f^{-1}$  is Lipschitz and  $f$  is blow-analytic.*

Theorem 5.3 gives a negative answer to Question 7.8 of [15]. As a corollary we obtain the following Inverse Function Theorem. By  $C^\omega$  we mean real analytic.

**Corollary 5.4.** *Let  $f : (\mathbb{R}^n, 0) \rightarrow (\mathbb{R}^n, 0)$  be a semialgebraic homeomorphism such that  $f^{-1}$  is blow-analytic. If  $f$  is  $C^k$ ,  $k = 1, 2, \dots, \infty, \omega$ , then so is  $f^{-1}$ .*

The proof of Theorem 5.3 uses the jet spaces of real analytic arcs and additive invariants of real algebraic sets.

## 6. ANALYTIC FAMILIES OF SYMMETRIC MATRICES

Arc-analytic phenomena appear in the theory of hyperbolic polynomials with analytic coefficients and analytic families of symmetric matrices. Let me first quote a classical result of F. Rellich [37] published in 1937, (see also [38]).

**Theorem 6.1.** *Let  $P(x, z) = z^d + \sum_{i=1}^d a_i(x)z^{d-i}$ , where  $a_i : I \rightarrow \mathbb{R}$  real analytic in an open interval  $I \subset \mathbb{R}$ . Assume that for each  $x \in I$  all roots of the polynomial  $z \mapsto P(x, z)$  are real (we call such a polynomial **hyperbolic**). Then there exist real analytic functions  $f_i : I \rightarrow \mathbb{R}$  such that*

$$P(x, z) = \prod_{i=1}^d [z - f_i(x)].$$

*Example 6.2.* Rellich's theorem fails if coefficients  $a_i$  depend on 2 variables, take for instance  $P(x, z) = z^2 - (x_1^2 + x_2^2)$ .

So if the coefficients  $a_i$  are analytic in open set  $\Omega \subset \mathbb{R}^n$ ,  $n \geq 2$ , then we don't have such a splitting. However  $P^{-1}(0)$ , the set of roots of  $P$ , can be naturally seen as a multivalued arc analytic function in variable  $x \in \Omega$ . It turns out that indeed this multivalued function has properties similar (and even stronger) to those discussed in the previous sections. These result were obtained by K. Kurdyka and L. Paunescu [25]. The first main result is a positive answer to a question posed by S. Łojasiewicz. Let  $P(x, z) = z^d + \sum_{i=1}^d a_i(x)z^{d-i}$ ,  $a_i : \Omega \rightarrow \mathbb{R}$  real analytic,  $\Omega \subset \mathbb{R}^n$  open. Assume that for each  $x \in \Omega$  all roots of the polynomial  $z \mapsto P(x, z)$  are real and denote them by  $\lambda_1(x) \leq \dots \leq \lambda_d(x)$ . So we have a mapping  $\Lambda : \Omega \rightarrow \mathbb{R}^d$ ,  $\Lambda(x) = (\lambda_1(x), \dots, \lambda_d(x))$ .

**Theorem 6.3.**  $\Lambda : \Omega \rightarrow \mathbb{R}^d$  is locally lipschitz.

The proof goes by reduction to the 2-dimensional case and a thorough study of a desingularization of such a polynomial. According to Bronshtein [3] and also Wakabayashi [40] this result holds actually with weaker assumption, that the coefficients are of the class  $C^d$ , but their proofs are difficult to follow.

**6.1. Desingularization of hyperbolic polynomials and analytic families.** Multiparameter versions of Rellich’s theorems were obtained in [25].

**Theorem 6.4.** *Consider a polynomial  $P(x, z) = z^d + \sum_{i=1}^d a_i(x)z^{d-i}$ , with  $a_i : \Omega \rightarrow \mathbb{R}$  real analytic functions in an open set  $\Omega \subset \mathbb{R}^n$ . Assume that for each  $x \in \Omega$  all roots of the polynomial  $z \mapsto P(x, z)$  are real. Then, there exists  $\sigma : W \rightarrow \Omega$  a locally finite composition of blowing-ups with smooth (global) centers, such that for any  $w_0 \in W$  there is a neighborhood  $U$  and analytic functions  $F_i : U \rightarrow \mathbb{R}$  such that*

$$P(w, z) = z^d + \sum_{i=1}^d a_i(\sigma(w))z^{d-i} = \prod_{i=1}^d [z - F_i(w)],$$

for any  $w \in U, z \in \mathbb{R}$ .

*Example 6.5.* Let  $z^2 - (x_1^2 + x_2^2)$ , put  $x_1 = w_1, x_2 = w_1 w_2$ , so  $P(w_1, w_2, z) = (z - F_1(w))(z - F_2(w))$ , with  $F_1 = w_1(1 + w_2^2)^{1/2}, F_2 = -w_1(1 + w_2^2)^{1/2}$  analytic functions.

Let  $\mathcal{S}_d$  stand for the space of symmetric  $d \times d$  matrices with real entries.

**Theorem 6.6.** *Consider an analytic family  $A : \Omega \rightarrow \mathcal{S}_d$  of symmetric matrices, where  $\Omega$  is an open connected subset of  $\mathbb{R}^m$ . Then, there exists  $\sigma : W \rightarrow \Omega$  a locally finite composition of blowing-ups with smooth (global) centers, such that for any  $w_0 \in W$  there is a neighborhood  $U$  such that the corresponding family  $A \circ \sigma|_U : U \rightarrow \mathcal{S}_d$  admits a simultaneous analytic diagonalization.*

The statement that the family of matrices  $A \circ \sigma|_U : U \rightarrow \mathcal{S}_d$  admits a simultaneous analytic diagonalization means that we can choose in an analytic way eigenvalues and eigenvectors of the family  $A \circ \sigma|_U$ . An analogous version of this theorem for antisymmetric matrices is also given in [25]. Recently these results were generalized and extended to the case of quasi-analytic families of symmetric and normal matrices by A. Rainer [36]. Another approach to a generalization of those result was given by K. J. Nowak [30].

REFERENCES

[1] O. M. Abderrahmane Yacoub : *Weighted homogeneous polynomials and blow-analytic equivalence*, in Singularity Theory and Its Applications, Advances Studies in Pure Mathematics **43**, 2006, Mathematical Society of Japan, Tokyo, 333–345.  
 [2] E. Bierstone, P. D. Milman, *Arc-analytic functions*, Invent. math. **101** (1990), 411–424.  
 [3] M.D. Bronshtein, *Smoothness of roots depending on parameter*, Sib. Math. J. **20** (1979), 347–352.  
 [4] M. Coste, *Real Algebraic Sets*, in "Arc Spaces and Additive Invariants in Real Algebraic Geometry", Panoramas et Synthèses **24**, 2007, S.M.F., pp. 1-32.

- [5] J. Denef, F. Loeser, *Germes of arcs on singular algebraic varieties and motivic integration*, Invent. math. **135** (1999) 201–232.
- [6] G. Fichou, *Motivic invariants of arc-symmetric sets and blow-Nash equivalence*, Compositio Math. **141** (2005) 655–688.
- [7] G. Fichou, *Zeta functions and Blow-Nash equivalence*, Annales Polonici Math., special volume in memory of S. Łojasiewicz, **87** (2005) 111–126
- [8] G. Fichou, *The corank and the index are blow-Nash invariants*, Kodai Math. J. 29 (2006), no. 1, 31–40.
- [9] G. Fichou, *Equivariant virtual Betti numbers*, Ann. Inst. Fourier (Grenoble) 58 (2008), no. 1, 1–27.
- [10] G. Fichou, *Blow-Nash types of simple singularities*, J. Math. Soc. Japan 60 (2008), no. 2, 445–470.
- [11] T. Fukui, *Seeking invariants for blow-analytic equivalence*, Compositio Math. **105** (1997), 95–107.
- [12] T. Fukui, S. Koike, T.-C. Kuo, *Blow-analytic equisingularities, properties, problems and progress*, Real Analytic and Algebraic Singularities (T. Fukuda, T. Fukui, S. Izumiya and S. Koike, ed), Pitman Research Notes in Mathematics Series, **381** (1998), pp. 8–29.
- [13] T. Fukui, K. Kurdyka, L. Paunescu, *An inverse mapping theorem for arc-analytic homeomorphisms*, Geometric singularity theory, 49–56, Banach Center Publ., 65, Polish Acad. Sci., Warsaw, 2004.
- [14] T. Fukui, K. Kurdyka, A. Parusiński, *Inverse Function Theorems for Arc-analytic Homeomorphisms*, arXiv:1003.0826.
- [15] T. Fukui, L. Paunescu, *On blow-analytic equivalence*, in "Arc Spaces and Additive Invariants in Real Algebraic Geometry", Panoramas et Synthèses **24**, 2007, S.M.F., pp. 87–122
- [16] T. Fukui, S. Koike, T.-C. Kuo, *Blow-analytic equisingularities, properties, problems and progress*, in "Real analytic and algebraic singularities", Pitman Research Notes in Mathematics Series, **381**, 1997, Longman, 8–29.
- [17] S. Koike and A. Parusiński, *Motivic-type invariants of blow-analytic equivalence*, Ann. Inst. Fourier **53** (2003), 2061–2104.
- [18] S. Koike, A. Parusiński, *Blow-analytic equivalence of two variable real analytic function germs*, J. Algebraic Geom. 19 (2010), no. 3, 439472.
- [19] S. Koike, A. Parusiński, *Equivalence relations for two variable real analytic function germs*, arXiv:0801.2650
- [20] T.-C. Kuo, *On classification of real singularities*, Invent. math. **82** (1985), 257–262.
- [21] K. Kurdyka, *Ensembles semi-algébriques symétriques par arcs*, Math. Ann. **281** no.3 (1988), 445–462.
- [22] K. Kurdyka, A. Parusiński, *Arc-symmetric sets and arc-analytic mappings*, in "Arc Spaces and Additive Invariants in Real Algebraic Geometry", Panoramas & Synthèses **24**, S.M.F. (2007), 33–67.
- [23] K. Kurdyka, A. Parusiński, *On the non-analyticity locus of an arc-analytic function* J. Algebraic Geom. 2011, to appear.
- [24] K. Kurdyka, L. Paunescu, *Arc-analytic roots of analytic functions are Lipschitz*, Proc. Amer. Math. Soc. 132 (2004), no. 6, 16931702.
- [25] K. Kurdyka, L. Paunescu, *Hyperbolic polynomials and multiparameter real-analytic perturbation theory*, Duke Math. J. 141 (2008), no. 1, 123149.
- [26] C. McCrory, A. Parusiński, *Algebraically Constructible Functions*, Annales Sci. Éc. Norm. Sup. **30**, 4 (1997), 527–552.
- [27] C. McCrory, A. Parusiński, *Virtual Betti numbers of real algebraic varieties*, Comptes Rendus Acad. Sci. Paris, Ser. I, **336** (2003), 763–768. See also <http://arxiv.org/pdf/math.AG/0210374>.

- [28] C. McCrory, A. Parusiński, *The weight filtration for real algebraic varieties*, in "Topology of Stratified Spaces", MSRI Publications Volume 58, 2011, Berkeley, California, 121-160.
- [29] J.F. Nash, *Arc structure of singularities*. A celebration of John F. Nash, Jr. Duke Math. J. 81 (1995), no. 1, 3138 (1996).
- [30] K. J. Nowak, *Quasianalytic perturbation of multiparameter hyperbolic polynomials an symmetric matrices*, Ann. Polon. Math. to appear.
- [31] A. Parusiński, *Subanalytic functions*, Trans. Amer. Math. Soc. **344**, 2 (1994), 583–595.
- [32] A. Parusiński, *Topology of Injective Endomorphisms of Real Algebraic Sets*, Math. Ann. **328** (2004), 353–372
- [33] A. Parusiński : *A criterion for the topological equivalence of two variable complex analytic function germs*, Proc. Japan Acad. Ser. A Math. Sci. Volume **84**, Number 8 (2008), 147–150.
- [34] L. Paunescu, *An example of blow-analytic homeomorphism* in "Real analytic and algebraic singularities", Pitman Research Notes in Mathematics Series, **381**, 1997, Longman, 62–63.
- [35] H. Pennaneac'h, *Virtual and non virtual algebraic Betti numbers*, Advances in Geometry, 5 (2005), no. 2, 187193.
- [36] A. Rainer, *Quasianalytic multiparameter perturbation of polynomials and normal matrices*, Trans. AMS, to appear.
- [37] F. Rellich, *Störungstheorie der Spektralzerlegung, I*, Math. Ann. **113** (1937), 600-619.
- [38] F. Rellich, *Perturbation theory of eigenvalue problem* Gordon and Breach, New York 1950.
- [39] B. Totaro, *Topology of singular algebraic varieties*, Proc. Int. Cong. Math. Beijing, vol. 1 (2002), 533-541.
- [40] S. Wakabayashi, *Remark on hyperbolic polynomials*, Tsukuba J. Math. **10** (1986), 17-28.

LABORATOIRE DE MATHÉMATIQUES, UMR 5175 DU CNRS, UNIVERSITÉ DE SAVOIE, CAMPUS SCIENTIFIQUE, 73 376 LE BOURGET-DU-LAC CEDEX, FRANCE,  
*E-mail address:* kurdyka@univ-savoie.fr



# Positive Polynomials and Sums of Squares: Theory and Practice

Victoria Powers \*

May 21, 2011

In theory, theory and practice are the same. In practice, they are different. - *A. Einstein*

If a real polynomial  $f$  in  $n$  variables can be written as a sum of squares of real polynomials, then clearly  $f$  must take only nonnegative values in  $\mathbb{R}^n$ . This simple, but powerful, fact and generalizations of it underlie a large body of theoretical and computational results concerning positive polynomials and sums of squares.

An explicit expression of  $f$  as a sum of squares is a *certificate of positivity for  $f$* , i.e., a polynomial identity which gives an immediate proof of the positivity of  $f$  on  $\mathbb{R}^n$ . In recent years, much work has been devoted to the study of certificates of positivity for polynomials. In this paper we will give an overview of some recent results in the theory and practice of positivity and sums of squares, with detailed references to the literature. By “theory”, we mean theoretical results concerning the existence of certificates of positivity. By “practice”, we mean work on computational and algorithmic issues, such as finding certificates of positivity for a given polynomial.

For the most part, we restrict results to those in a real polynomial ring. This is somewhat misleading, since it is impossible to prove most of the results for polynomials without using a more abstract approach. For example, in order to obtain a solution to Hilbert’s 17th problem, it was necessary for Artin (along with Schreier) to first develop the theory of ordered fields! The reader should keep in mind that underneath the theorems in this paper lie the elegant and beautiful subjects of Real Algebra and Real Algebraic Geometry, among others.

The subject of positivity and sums of squares has been well-served by its expositors. There are a number of books and survey articles devoted to various aspects of the subject. Here we mention a few of these that the interested reader could consult for more details and background on the topics covered in this paper, as well as related topics that are not

---

\*Department of Mathematics and Computer Science, Emory University, Atlanta, GA 30322. Email: vicki@mathcs.emory.edu.

included: There are the books by Prestel and Delzell [58] and Marshall [33] on positive polynomials, a survey article by Reznick [63] about psd and sos polynomials with a wealth of historical information, and a recent survey article by Scheiderer [70] on positivity and sums of squares which discusses results up to about 2007. Finally, there is a survey article by Laurent [31] which discusses positivity and sums of squares in the context of applications to polynomial optimization.

Many worthy topics and results did not make it into this article due to lack of time; we hope to expand this article in the near future. In particular, we hope to include a section on applications in a future version.

## 1 Preliminaries and background

In this section, we introduce the basic concepts and review some of the fundamental results in the subject, starting with results in the late 19th century. For a fuller account of the historical background, see the survey [63]. For a more detailed survey of the subject up to about 2007, readers should consult the survey article [70].

### 1.1 Notation

Throughout, we fix  $n \in \mathbb{N}$  and let  $\mathbb{R}[X]$  denote the real polynomial ring  $\mathbb{R}[X_1, \dots, X_n]$ . We denote by  $\mathbb{R}[X]^+$  the set of polynomials in  $\mathbb{R}[X]$  with nonnegative coefficients. The following monomial notation is convenient: For  $\alpha = (\alpha_1, \dots, \alpha_n) \in \mathbb{N}^n$ , let  $X^\alpha$  denote  $X_1^{\alpha_1} \cdots X_n^{\alpha_n}$ . For a commutative ring  $A$ , we denote the set of sums of squares of elements of  $A$  by  $\sum A^2$ .

We define the basic objects studied in real algebraic geometry. Given a set  $G$  of polynomials in  $\mathbb{R}[X]$ , the closed semialgebraic set defined by  $G$  is

$$\mathcal{S}(G) := \{x \in \mathbb{R}^n \mid g(x) \geq 0 \text{ for all } g \in G\}.$$

If  $G$  is finite,  $\mathcal{S}(G)$  is the basic closed semialgebraic set generated by  $G$ .

The basic algebraic objects of interest are defined as follows. For a finite subset  $G = \{g_1, \dots, g_r\}$  of  $\mathbb{R}[X]$ , the preordering generated by  $G$  is

$$PO(G) := \left\{ \sum_{e=(e_1, \dots, e_r) \in \{0,1\}^r} s_e g_1^{e_1} \cdots g_r^{e_r} \mid \text{each } s_e \in \sum \mathbb{R}[X]^2 \right\}.$$

The quadratic module generated by  $G$  is

$$M(G) := \{s_0 + s_1 g_1 + \cdots + s_r g_r \mid \text{each } s_i \in \sum \mathbb{R}[X]^2\}.$$

Notice that if  $f \in PO(G)$  or  $f \in M(G)$ , then  $f$  is clearly positive on  $\mathcal{S}(G)$  and an identity  $f = \sum_{e \in \{0,1\}^r} s_e g_1^{e_1} \cdots g_r^{e_r}$  or  $f = s_0 + s_1 g_1 + \cdots + s_r g_r$  is a certificate of positivity for  $f$  on  $\mathcal{S}(G)$ .

Traditionally, a result implying the existence of certificates of positivity for polynomials on semialgebraic sets is called a *Positivstellensatz* or a *Nichtnegativstellensatz*, depending on whether the polynomial is required to be strictly positive or non-strictly positive on the set. We will use the term “representation theorem” for any theorem of this type and refer to a “representation of  $f$ ” (as a sum of squares, in the preordering, etc.), meaning an explicit identity for  $f$ .

## 1.2 Classic results

A polynomial  $f \in \mathbb{R}[X]$  is positive semidefinite, psd for short, if  $f(x) \geq 0$  for all  $x \in \mathbb{R}^n$ . We say  $f$  is sos if  $f \in \sum \mathbb{R}[X]^2$ . Of course,  $f$  sos implies that  $f$  is psd, and for  $n = 1$ , the converse follows from the Fundamental Theorem of Algebra.

We begin our story in 1888, when the 26-year-old Hilbert published his seminal paper on sums of squares [20] in which he showed that for  $n \geq 3$ , there exist psd forms (homogenous polynomials) in  $n$  variables which are not sums of squares.<sup>1</sup> In the same paper, he proved that every psd ternary quartic – homogenous polynomial of degree 4 in 3 variables – is a sum of squares. Hilbert was able to prove that for  $n = 3$ , every psd form is a sum of squares of rational functions, but he was not able to prove this for  $n > 2$ . This became the seventeenth on his famous list of twenty-three mathematical problems that he announced at the 1900 International Congress of Mathematicians in Berlin. In 1927, E. Artin [1] settled the question:

**Theorem 1** (Artin’s Theorem). *Suppose  $f \in \mathbb{R}[X]$  is psd, then there exists nonzero  $g \in \mathbb{R}[X]$  such that  $g^2f$  is sos.*

The following Positivstellensatz has until recently been attributed to Stengle [79], who proved it in 1974. It is now known that the main ideas were in a paper of Krivine’s from the 1960’s.

**Theorem 2** (Classical Positivstellensatz). *Suppose  $S = \mathcal{S}(G)$  for finite  $G \subseteq \mathbb{R}[X]$  and  $f \in \mathbb{R}[X]$  with  $f > 0$  on  $S$ . Then there exist  $p, q \in PO(G)$  such that  $pf = 1 + q$ .*

## 1.3 Bernstein’s and Pólya’s theorems

Certificates of positivity for a univariate  $p \in \mathbb{R}[x]$  such that  $p \geq 0$  or  $p > 0$  on an interval  $[a, b]$  have been studied since the late 19th century.

<sup>1</sup>Hilbert worked with forms, however for the purposes of this paper we prefer to work in a non-homogenous setting. A form can be dehomogenized into a polynomial in one less variable and the properties of being psd and sos are inherited under dehomogenization. When discussing work related to Hilbert’s work, we will use the language of forms, otherwise, we state results in terms of polynomials.



Questions about polynomials positive on an interval come in part from the relationship with the classic Moment Problem, in particular, Hausdorff’s solution to the Moment Problem on  $[0, 1]$  [19].

In 1915, Bernstein [4] proved that if  $p \in \mathbb{R}[x]$  and  $p > 0$  on  $(-1, 1)$ , then  $p$  can be written as a positive linear combination of polynomials  $(1 - x)^i(1 + x)^j$  for suitable integers  $i$  and  $j$ ; however, it might be necessary for  $i + j$  to exceed the degree of  $p$ . Notice that writing  $p$  as such a positive linear combination is a certificate of positivity for  $p$  on  $[-1, 1]$ .

Pólya’s Theorem, which he proved in 1928 [47], concerned forms which are positive on the standard  $n$ -simplex  $\Delta_n := \{(x_1, \dots, x_n) \in \mathbb{R}^n \mid x_i \geq 0, \sum_i x_i = 1\}$ .

**Theorem 3** (Pólya’s Theorem). *Suppose  $f \in \mathbb{R}[X]$  is homogeneous and is strictly positive on  $\Delta_n$ , then for sufficiently large  $N$ , all of the coefficients of  $(X_1 + \dots + X_n)^N f$  are positive.*

Here “all coefficients are positive” means that every monomial of degree  $\deg f + N$  appears with a strictly positive coefficient.

Bernstein’s result is equivalent to the one-variable dehomogenized version of Pólya’s Theorem: If  $p \in \mathbb{R}[x]$  is positive on  $(0, \infty)$ , then there exists  $N \in \mathbb{N}$  such that  $(1 + x)^N p$  has only positive coefficients. The equivalence is immediate by applying the “Goursat transform” which sends  $p$  to

$$(x + 1)^d p \left( \frac{1 - x}{1 + x} \right),$$

where  $d = \deg p$ .

### 1.4 Schmüdgen’s Theorem and beyond

In 1991, Schmüdgen [74] proved his celebrated theorem on representations of polynomials strictly positive on compact basic closed semialgebraic sets. This result began a period of much activity in Real Algebraic Geometry, which continues today, and stimulated new directions of research.

**Theorem 4** (Schmüdgen’s Positivstellensatz). *Suppose  $G$  is a finite subset of  $\mathbb{R}[X]$  and  $\mathcal{S}(G)$  is compact. If  $f \in \mathbb{R}[X]$  is such that  $f > 0$  on  $\mathcal{S}(G)$ , then  $f \in PO(G)$ .*

Schmüdgen’s theorem yields “denominator-free” certificates of positivity, in contrast to Artin’s theorem and the Classic Positivstellensatz. The underlying reason that such certificates exist is that the preordering  $PO(G)$  in this case is *archimedean*: Given any  $h \in \mathbb{R}[X]$ , there exists  $N \in \mathbb{N}$  such that  $N \pm h \in PO(G)$ . Equivalently, there is some  $N \in \mathbb{N}$  such that  $N - \sum X_i^2 \in PO(G)$ . It is a fact that if  $\mathcal{S}(G)$  is compact, then  $PO(G)$  is

archimedean. This follows from Schmüdgen's proof of his theorem; there is a direct proof due to Wörmann [81].

The definition of archimedean for a quadratic module  $M$  is the same as for a preordering. If  $M(G)$  is archimedean, then it is immediate that  $\mathcal{S}(G)$  is compact; the converse is not true in general. In 1993, Putinar [59] gave a denominator-free representation theorem for archimedean quadratic modules.

**Theorem 5** (Putinar's Positivstellensatz). *Suppose  $G$  is a finite subset of  $\mathbb{R}[X]$  and  $M(G)$  is archimedean. If  $f \in \mathbb{R}[X]$  is such that  $f > 0$  on  $\mathcal{S}(G)$ , then  $f \in M(G)$ .*

In 1999, Scheiderer began a systematic study of questions concerning the existence of certificates of positivity in a broader setting. Let  $A$  be a commutative ring, then  $a \in A$  is called psd if its image is nonnegative in every element of the real spectrum of  $A$ . One then asks when does psd = sos in  $A$ ? In a series of fundamental papers, Scheiderer settles this question in many cases for coordinate rings of real affine varieties, and more general rings [66], [67], [69], [72], [73]. This work led to many new representation theorems for polynomial rings. See [70] for a detailed account.

## 2 Theory: Certificates of Positivity

In this section we look at very recent theoretical results concerning sums of squares, psd polynomials, and certificates of positivity. We start with some modern riffs on Hilbert's 1888 paper. We then look at the sums of squares on algebraic curves. We discuss stability in quadratic modules, a topic which is important in computational questions and applications. Finally, we look at recent work concerning sums of squares in cases where the polynomials have some special structure.

### 2.1 Psd ternary quartics

Hilbert's 1888 proof that a psd ternary quartic is a sum of three squares of quadratic forms is short, but difficult; arguably a high point of 19th century algebraic geometry. Even today the proof is not easy to understand and Hilbert's exposition lacks details in a number of key points. Several authors have given modern expositions of Hilbert's proof, with details filled in.

There is an approach due to Cassels, published in Rajwade's book Squares [61, Chapter 7], and articles by Rudin [64] and Swan [80]. In 1977, Choi and Lam [11] gave a short elementary proof that a psd ternary quartic must be a sum of five squares of quadratic forms. In 2004, Pfister [43] gave an elementary proof that a psd ternary quartic is a sum of

four squares of quadratic forms and he gave an elementary and constructive argument in the case that the ternary quartic has a non-trivial real zero. Very recently, Pfister and Scheiderer [44] gave a complete proof of Hilbert’s Theorem, using only elementary tools such as the theorems on implicit functions and symmetric functions.

In the “Practice” section of this paper, we will discuss computational issues around Hilbert’s theorem on ternary quartics.

## 2.2 Hilbert’s construction of psd, not sos, polynomials

In Hilbert’s 1888 paper, he described how to find psd forms which are not sums of squares. However, his construction did not yield an explicit example of a psd, not sos, polynomial. It took nearly 80 years for an explicit example of a psd, not sos, polynomial to appear in the literature; the first published example was due to Motzkin. Since then, other examples and families of examples have been produced (see the survey [63] for a detailed account), however only recently has there been attempts to understand Hilbert’s proof and make it constructive.

Reznick [62] has isolated the underlying mechanism of Hilbert’s construction and shown that it applies to more general situations than those considered by Hilbert. He is then able to produce many new examples of psd, not sos, polynomials.

Hilbert’s proof, and Reznick’s modern exposition and generalization, use the fact that forms of degree  $d$  satisfy certain linear relations, known as the Cayley-Bacharach relations, which are not satisfied by forms of full degree  $2d$ . Very recently, Blekherman [6] shows that the Cayley-Bacharach relations are, in fact, the fundamental reason that there are psd polynomials that are not sos. In small cases, he is able to give a complete characterization of the difference between psd and sos forms. For example, the result for forms of degree 6 in 3 variables is the following:

**Theorem 6** ([6],Theorem 1.1). *Let  $H_{3,6}$  be the vector space of degree 6 forms in 3 variables. Suppose  $p \in H_{3,6}$  is psd and not sos. Then there exist two real cubics  $q_1, q_2$  intersecting in 9 (possibly complex) projective points  $\gamma_1, \dots, \gamma_9$  such that the values of  $p$  on  $\gamma_i$  certify that  $p$  is not a sum of squares in the following sense: There is a linear functional  $l$  on  $H_{3,6}$ , defined in terms of the  $\gamma_i$ ’s, such that  $l(q) \geq 0$  for all sos  $q$  and  $l(p) < 0$ .*

## 2.3 Polynomials positive on noncompact semialgebraic sets

We now turn to representation theorems for polynomials positive on noncompact basic closed semialgebraic sets. Given finite  $G \subseteq \mathbb{R}[X]$ , let  $\mathcal{S} = \mathcal{S}(G)$  and suppose that  $\mathcal{S}$  is not compact. Let  $\mathcal{P} = PO(G)$  and  $M = M(G)$ .

We would like to know if Schmüdgen's Theorem or Putinar's Theorem extends to this case: Given  $f > 0$  on  $\mathcal{S}$ , is  $f \in \mathcal{P}$  or  $f \in M$ ? More generally, we can ask whether this holds for  $f \geq 0$  on  $\mathcal{S}$ , in which case we say that  $\mathcal{P}$  or  $M$  is *saturated*. We have the following negative results due to Scheiderer:

**Theorem 7** ([66]). *1. Suppose  $\dim \mathcal{S} \geq 3$ . Then there exists  $p \in \mathbb{R}[X]$  such that  $p \geq 0$  on  $\mathbb{R}^n$  and  $p \notin \mathcal{P}$ .*

*2. If  $n = 2$  and  $\mathcal{S}$  contains an open 2-dimensional cone, then there is  $p \in \mathbb{R}[X]$  with  $p \geq 0$  on  $\mathbb{R}^2$  and  $p \notin \mathcal{P}$ .*

In contrast to these, the  $n = 1$  case has been completely settled, by Kuhlmann and Marshall [27], extending work of Berg and Maserick [3]. In this case, the preordering  $\mathcal{P}$  is saturated, provided one chooses the right set of generators.

**Definition 1** ([27], 2.3). Suppose  $\mathcal{S}$  is a closed semialgebraic set in  $\mathbb{R}$ , then  $\mathcal{S}$  is a union of finitely many closed intervals and points. Define a set of polynomials  $F$  in  $\mathbb{R}[x]$  as follows:

- If  $a \in \mathcal{S}$  and  $(-\infty, a) \cap \mathcal{S} = \emptyset$ , then  $x - a \in F$ .
- If  $a \in \mathcal{S}$  and  $(a, \infty) \cap \mathcal{S} = \emptyset$ , then  $ax \in F$ .
- If  $a, b \in \mathcal{S}$  and  $(a, b) \cap \mathcal{S} = \emptyset$ , then  $(x - a)(x - b) \in F$ .

It is easy to see that  $\mathcal{S}(F) = \mathcal{S}$ ;  $F$  is called the **natural choice of generators for  $\mathcal{S}$** .

**Theorem 8** ([27], Thm. 2.2, Thm. 2.5). *Let  $\mathcal{S}$  be as above and suppose  $G$  is any finite subset in  $\mathbb{R}[X]$  such that  $\mathcal{S}(G) = \mathcal{S}$ . Let  $\mathcal{P} = PO(G)$  and let  $F$  be the natural choice of generators.*

- 1. Every  $p \in \mathbb{R}[x]$  such that  $p \geq 0$  on  $\mathcal{S}$  is in  $\mathcal{P}$  iff the set of generators  $G$  of  $\mathcal{S}$  contains  $F$ .*
- 2. Let  $M = M(F)$ , then every  $p \in \mathbb{R}[x]$  such that  $p \geq 0$  on  $\mathcal{S}$  is in  $M$  iff  $|F| \leq 1$ , or  $|F| = 2$  and  $\mathcal{S}$  has an isolated point.*

We are left with the case of noncompact semialgebraic subsets of  $\mathbb{R}^2$  which do not contain a 2-dimensional cone. We write  $\mathbb{R}[x]$  for the polynomial ring in one variable and  $\mathbb{R}[x, y]$  for the polynomial ring in two variables. The first example given of a noncompact basic closed semialgebraic set in  $\mathbb{R}^2$  for which the corresponding preordering is saturated is due to Scheiderer [69]. His example is the preordering in  $\mathbb{R}[x, y]$  generated by  $\{x, 1 - x, y, 1 - xy\}$ . Powers and Reznick [52] studied polynomials positive on noncompact rectangles in  $\mathbb{R}^2$  and obtained some partial results. They

showed that if  $F = \{f_1, \dots, f_r, y\}$  with  $f_1, \dots, f_r \in \mathbb{R}[x]$  and  $\mathcal{S}(F)$  is the half-strip  $[0, 1] \times \mathbb{R}^+$ , then there always exists  $g > 0$  on  $[0, 1] \times \mathbb{R}^+$  with  $g \notin M(F)$ . On the other hand, it is shown that under a certain condition,  $g \geq 0$  on  $[0, 1] \times \mathbb{R}$  implies  $g = s + t(x - x^2)$  with  $s, t \in \sum \mathbb{R}[x, y]^2$ . Recently, Marshall proved this without the condition on  $g$ , settling a long-standing open problem.

**Theorem 9** ([34]). *Suppose  $p \in \mathbb{R}[x, y]$  is non-negative on the strip  $[0, 1] \times \mathbb{R}$ . Then there exist  $s, t \in \sum \mathbb{R}[x, y]^2$  such that  $p = s + t(x - x^2)$ .*

In other words, any  $p$  which is nonnegative on the strip  $[0, 1] \times \mathbb{R}$  is in the quadratic module  $M(x - x^2)$ . This result has been extended by H. Nguyen in her PhD thesis [37] and by Nguyen and Powers.

**Theorem 10** ([38], Thm. 2). *Suppose  $U \subseteq \mathbb{R}$  is compact and  $F$  is the natural choice of generators for  $U$ . Let  $\mathcal{S} = U \times \mathbb{R} \subseteq \mathbb{R}^2$  and let  $M$  be the quadratic module in  $\mathbb{R}[x, y]$  generated by  $F$ . Then every  $p \in \mathbb{R}[x, y]$  with  $p \geq 0$  on  $\mathcal{S}$  is in  $M$ .*

By the result from [52], we know that this does not generalize to the half-strip case, however we do obtain a representation theorem if the quadratic module is replaced by a preordering and we use the natural choice of generators.

**Theorem 11** ([38], Thm. 3). *Given compact  $U \subseteq \mathbb{R}$  with natural choice of generators  $\{s_1, \dots, s_k\}$  and  $q(x) \in \mathbb{R}[x]$  with  $q(x) \geq 0$  on  $U$ , let  $F = \{s_1, \dots, s_k, y - q(x)\}$ , so that  $\mathcal{S}(F)$  is the upper half of the strip  $U \times \mathbb{R}$  cut by  $\{q(x) = 0\}$ . If  $\mathcal{P}$  is the preordering in  $\mathbb{R}[x, y]$  generated by  $F$ , then  $\mathcal{P}$  is saturated.*

There are also examples for which no corresponding finitely generated preorder is saturated. The following from [38] is a generalization of an example from [13] due to Netzer.

**Example 1.** Suppose  $F = \{x - x^2, y^2 - x, y\}$ , so that  $\mathcal{S} = \mathcal{S}(F)$  is the half-strip  $[0, 1] \times \mathbb{R}^+$  cut by the parabola  $y^2 = x$ . Then for any  $\tilde{F} \subseteq \mathbb{R}[x, y]$  such that  $\mathcal{S}(\tilde{F}) = \mathcal{S}$ , there is some  $p \in \mathbb{R}[x, y]$  such that  $p \geq 0$  on  $\mathcal{S}$  and  $p \notin PO(\tilde{F})$ .

For all of the positive examples above, the fibers  $\mathcal{S} \cap \{y = a\}$  are connected. It is not known if there are positive examples for which this doesn't hold, e.g., we have the following open problem:

**Question:** Let  $\mathcal{S} = \mathcal{S}(\{x - x^2, y^2 - 1\})$  in  $\mathbb{R}^2$ , so that  $\mathcal{S} = [0, 1] \times ((-\infty, -1] \cup [1, \infty))$ . Given  $g \in \mathbb{R}[x, y]$  such that  $g \geq 0$  on  $\mathcal{S}$ , is  $g \in PO(\{x - x^2, y^2 - 1\})$ ?

## 2.4 Sums of squares on real algebraic varieties

We now look at a more general setting than polynomial rings. Let  $V$  be an affine variety defined over  $\mathbb{R}$ ,  $\mathbb{R}[V]$  the coordinate ring of  $V$ , and  $V(\mathbb{R})$  the set of real points of  $V$ . Then  $f \in \mathbb{R}[V]$  is psd if  $f(x) \geq 0$  for all  $x \in V(\mathbb{R})$ , and  $f$  is sos if  $f$  is a finite sum of squares of elements of  $\mathbb{R}[V]$ . It is interesting to ask whether psd = sos in this more general setting.

If  $\dim(V) \geq 3$ , then Hilbert's result that psd  $\neq$  sos has been extended to  $\mathbb{R}[V]$  by Scheiderer [66]. In the dimension 2 case, Scheiderer proves the surprising theorem that if  $V$  is a nonsingular affine surface and  $V(\mathbb{R})$  is compact, then psd = sos holds on  $V$ , see [69]. There is a nice application of this to Hilbert's 17th problem: If  $f \in \mathbb{R}[x, y, z]$  is a psd ternary form and  $g$  is any positive definite ternary form, then there exists  $N \in \mathbb{N}$  such that  $g^N f$  is sos.

The case where  $\dim(V) = 1$  (real algebraic curves) is completely understood in the case where  $V$  is irreducible, again due to Scheiderer [67]. In 2010, Plaumann [45] showed that in the reducible case, the answer depends on the irreducible components of the curve, and also on how these irreducible components are configured with respect to each other. He gives necessary and sufficient conditions for psd = sos in this case. He shows, for example, that for the family of curves  $C_a = \{(y - x^2)(y - a) = 0\}$  for  $a \in \mathbb{R}$  (the union of a parabola and a line), psd  $\neq$  sos always.

## 2.5 Stability

A quadratic module  $M = M(g_1, \dots, g_k)$  in  $\mathbb{R}[X]$  is **stable** if there exists a function  $\phi : \mathbb{N} \rightarrow \mathbb{N}$  such that the following holds: For every  $d \in \mathbb{N}$  and every  $f \in M$  with  $\deg f \leq d$ , there is a representation of  $f$  in  $M$ ,  $f = s_0 + s_1 g_1 + \dots + s_k g_k$  such that for all  $i$ ,  $\deg s_i \leq \phi(d)$ . A similar definition can be made for preorders, although stability has been studied mostly in the quadratic module case. The notion of stability was introduced in [55], where it was used to study the multivariable Moment Problem for noncompact semialgebraic sets.

The easiest example of a stable quadratic module in  $\mathbb{R}[X]$  is  $\sum \mathbb{R}[X]^2$ : If  $f$  is sos and  $f = h_1^2 + \dots + h_r^2$ , then for all  $i$ ,  $\deg h_i^2 \leq \deg f$ , since the leading forms of the  $h_i^2$ 's cannot cancel. A generalization of this simple argument yields families of stable preorderings in [55]. (The arguments apply immediately to quadratic modules as well.) On the other hand, if  $\mathcal{S}(G)$  has dimension  $\geq 2$  and  $M(G)$  is archimedean, then  $M(G)$  is never stable; this follows from [68, Thm. 5.4].

The notion of stability is important for computational problems as well as applications to the Moment Problem. It is this key property of stability that allows for effective algorithms for the problem of deciding whether

$f \in \mathbb{R}[X]$  is sos, and finding an explicit representation if so. See §3.1 for further discussion of these algorithms. In the case of compact semialgebraic sets, the non-stability of the underlying preordering or quadratic module means the problem of finding representations of polynomials positive on the set must be difficult.

Netzer [36] generalizes the idea of stability of a quadratic module to the notion of stable with respect to a given grading on a polynomial ring. The usual notion of stability is then stability with respect to the standard grading. Considering stability with respect to other gradings allows the development of tools to prove stability with respect to the standard grading by proving it first for finitely many non-standard ones. The paper [36] contains interesting new examples of stable quadratic modules.

## 2.6 Certificates of positivity for polynomials with special structure

If a polynomial  $f$  for which there is a certificate of positivity has some special structure, it can happen that there exists a certificate of positivity with nice properties related to the structure. This can have implications for applications, since it can imply the existence of smaller certificates for  $f$  than the general theory implies.

### 2.6.1 Invariant sums of squares

In practical applications of sums of squares, there is often some inherent symmetry in the problem. This symmetry can be exploited to yield finer representation theorems which in turn can lead to a reduction in problem size for applications.

Consider the following general situation: Suppose  $K$  is a closed subset of  $\mathbb{R}^n$  which is invariant under some subgroup  $G$  of the general linear group. Can we characterize  $G$ -invariant polynomials which are positive on  $K$ ? For example, can they be described in terms of invariant sums of squares, or even sums of squares of invariant polynomials?

Gatermann and Parrilo [17] considered these questions in the context of finding effective sum of squares decompositions of invariant polynomials. They look at finding a decomposition of an sos polynomial  $f$  which is invariant under the action of a finite group. Cimpric, Kuhlmann, and Scheiderer [13] consider a more general set-up:  $G$  is a reductive group over  $\mathbb{R}$  acting on an affine  $\mathbb{R}$ -variety  $V$  with an induced dual action on the coordinate ring  $\mathbb{R}[V]$  and on the linear dual space of  $\mathbb{R}[V]$ . In this setting, given an invariant closed semialgebraic set  $K$  in  $\mathbb{R}^n$ , they study the problem of representations of invariant polynomials that are positive on  $K$  using invariant sums of squares. Most of their results apply in the

case where the group  $G(\mathbb{R})$  is compact. They obtain a generalization of the main theorem of [17] and apply their results to an investigation of the equivariant version of the  $K$ -moment problem.

### 2.6.2 Polynomials with structured sparsity

We discuss a “sparse” version of Putinar’s theorem, where the variables consist of finitely many blocks that are allowed to overlap in certain ways, and we seek a certificate of positivity for a polynomial  $f$  that is sparse in the sense that each monomial in  $f$  involves only variables in one block. Then there is a representation of  $f$  in the quadratic module in which the sums of squares respect the block structure.

For  $I \subseteq \{1, \dots, n\}$ , let  $X_I$  denote the set of variables  $\{X_i \mid i \in I\}$  and  $\mathbb{R}[X_I]$  the polynomial ring in the variables  $X_I$ . Suppose that  $I_1, \dots, I_r$  are subsets of  $\{1, \dots, n\}$  satisfying the *running intersection property*: For all  $i = 2, \dots, r$ , there is some  $k < i$  such that  $I_i \cap \bigcup_{j < i} I_j \subseteq I_k$ . Suppose that for each  $i, i = 1, \dots, r$ , we are given a finite set of polynomials  $G_i = \{g_1^{(i)}, \dots, g_{l_i}^{(i)}\}$  in  $\mathbb{R}[X_{I_i}]$ . Then let  $S_j = \mathcal{S}(G_j)$  and let  $M_j$  be the quadratic module in  $\mathbb{R}[X_{I_j}]$  generated by  $G_j$ . Also, let  $S = \bigcap_j S_j$ . The following theorem was proven by Lasserre [30] in the case where  $S$  has non-empty interior and in the general case by Kojima and Muramatsu [26]:

**Theorem 12.** *Suppose all of the quadratic modules  $M_j$  are archimedean, and  $f \in \mathbb{R}[X_{I_1}] + \dots + \mathbb{R}[X_{I_k}]$  is strictly positive on  $S$ . Then  $f \in M_1 + \dots + M_k$ .*

Notice that the case  $r = 1$  is Putinar’s Theorem. Grimm, Netzer, and Schweighofer [18] gave a new simple proof of the theorem.

### 2.7 Pure states and sums of squares

Recently, a new approach to certificates of positivity for polynomials non-negative on compact basic closed semialgebraic has been introduced by Burgdorf, Scheiderer, and Schweighofer [8]. Their techniques allow simple, uniform proofs of already known representation theorems, as well as several new results.

This new approach is based on pure states of convex cones in  $\mathbb{R}[X]$ . The techniques come from the Eidelheit-Kakutani separation theorem for convex sets in a real vector space  $V$  and when combined with the Krein-Milman theorem yield a sufficient condition for membership in a convex cone  $C \subseteq V$  provided that  $C$  has an order unit (an algebraic interior point). This condition can then be applied to preorderings and quadratic modules in  $\mathbb{R}[X]$ . Here is a concrete example of the type of results that are



proven. Recall that a *semiring* in commutative ring is a subset containing  $\{0, 1\}$  and closed under addition and multiplication.

**Theorem 13** ([8], Theorem 7.8). *Let  $K \subseteq \mathbb{R}^n$  be a nonempty compact convex polyhedron defined by linear inequalities  $g_1 \geq 0, \dots, g_s \geq 0$ . Let  $S$  be the semiring in  $\mathbb{R}[X]$  generated by  $\mathbb{R}^+$  and the polynomials  $g_1, \dots, g_s$ . Let  $F$  be a face of  $K$  and suppose  $f \in \mathbb{R}[X]$  satisfies  $f|_F = 0$  and  $f|_{K \setminus F} > 0$ . For every  $z \in F$  and every  $y \in K \setminus F$ , assume  $D_{y-z}f(z) > 0$ . Then  $f \in S$ .*

Here  $D_v f(z)$  denotes the directional derivative of  $f$  at  $z$  in the direction of  $v$ . Roughly speaking, the last assumption in the theorem says that every directional derivative of  $f$  at a point of  $F$  pointing into  $K$  and not tangential to  $F$  should be strictly positive.

Previous to this work, examples of Nichtnegativstellensätze required that the nonnegative polynomial  $f$  on a compact basic closed semialgebraic set  $\mathcal{S}$  have discrete zeros in  $\mathcal{S}$ . Results in [8] are the first that allow  $f$  to have arbitrary zeros in  $\mathcal{S}$ .

**Example 2** ([8], Example 7.13). Suppose  $M$  is an archimedean quadratic module in  $\mathbb{R}[x, y, z]$ ,  $K = \{x \in \mathbb{R}^3 \mid g(x) = 0 \text{ for all } g \in M\}$  and let  $Z = \{(0, 0, t) \mid t \in \mathbb{R}\}$ , the  $z$ -axis in  $\mathbb{R}^3$ . Assume  $p, q, r \in \mathbb{R}[x, y, z]$  are such that

$$f = x^2p + y^2q + 2xyr,$$

$f > 0$  on  $\mathcal{S} \setminus Z$ , and  $f = 0$  on  $Z$ . Then if  $p$  and  $pq - r^2$  are strictly positive on  $Z \cap \mathcal{S}$ ,  $f \in M$ .

### 3 Practice: Computational and algorithmic issues

Recently, there has been much interest in developing algorithms for deciding positivity of a polynomial and finding certificates of positivity, in part because of the many applications of these algorithms. In this section, we discuss computational problems and issues related to positivity and sums of squares. We will discuss algorithms for finding explicit certificates of positivity for  $f \in \mathbb{R}[X]$ , both in the global case (sums of squares) and for  $f$  positive on a compact basic closed semialgebraic set (algorithmic Schmüdgen and Putinar theorems). We also discuss computational issues around Bernstein's Theorem and Pólya's Theorem as well as quantitative questions on psd ternary quartics (Hilbert's Theorem).

#### 3.1 Finding sum of squares representations

For  $f \in \mathbb{R}[X]$ , suppose we would like to decide if  $f$  is sos and if so, find an explicit representation of  $f$  as a sum of squares. The method we describe,

sometimes called the *Gram matrix method* reduces the problem to linear algebra. For more details and examples, see e.g. [12], [56], [31, §3.3].

Suppose  $f \in \mathbb{R}[X]$  has degree  $2d$ , let  $N = \binom{n+d}{d}$  and let  $V$  be the  $N \times 1$  vector of all monomials in  $\mathbb{R}[X]$  of degree at most  $d$ . Then  $f$  is sos iff there exists an  $N \times N$  symmetric psd matrix  $\mathcal{A}$  such that

$$f(X) = V \cdot \mathcal{A} \cdot V^T, \tag{1}$$

The set of matrices  $\mathcal{A}$  such that (1) holds is an affine subset  $\mathcal{L}$  of the space of  $N \times N$  symmetric matrices; a matrix in  $\mathcal{L}$  is often called a Gram matrix for  $f$ . Then  $f$  is sos iff  $\mathcal{L} \cap P_N \neq \emptyset$ , where  $P_N$  is the convex cone of psd symmetric  $N \times N$  matrices over  $\mathbb{R}$ . Finding this intersection is a *semidefinite program* (SDP). There are good numerical algorithms – and software – for solving semidefinite programs. For details on using SDPs to find sum of squares representations, see e.g. [41], [57].

Since there is an *a priori* bound on the size of the SDP corresponding to writing a particular  $f$  as a sum of squares, this gives an exact algorithm. However, since we are using numerical software, there are issues of exact versus numerical answers.

Consider the following example, due to C. Hillar: Suppose

$$f = 3 - 12y - 6x^3 + 18y^2 + 3x^6 + 12x^3y - 6xy^3 + 6x^2y^4,$$

is  $f$  sos? If we try to decide this with software we might get the answer “yes” and a decomposition similar to this:

$$f = (x^3 + 3.53y + .347xy^2 - 1)^2 + (x^3 + .12y + 1.53xy^2 - 1)^2 + (x^3 + 2.35y - 1.88xy^2 - 1)^2. \tag{2}$$

The coefficients of the right-hand side of (2) are not exactly the same as the coefficients of  $f$ , so we might wonder if  $f$  is really sos. It turns out that  $f$  is sos, and (2) is an approximation of a decomposition for  $f$  of the form

$$(x^3 + a^2y + bxy^2 - 1)^2 + (x^3 + b^2y + cxy^2 - 1)^2 + (x^3 + c^2y + axy^2 - 1)^2,$$

where  $a, b, c$  are real roots of  $x^3 - 3x + 1$ .

In theory, a SDP problem can be solved purely algebraically, for example, using quantifier elimination. In practice, this is impossible for all but trivial problems. Work by Nie, Ranestad, and Sturmfels [39] shows that optimal solutions of relatively small SDP’s can have minimum defining polynomials of huge degree, and hence we could encounter sos polynomials of relatively small size which have decompositions using algebraic numbers of large degree.

Since solving the underlying SDP exactly is impossible in most cases, we are led to the following question: Suppose  $f \in \sum \mathbb{Q}[X]^2$  and we find a

numerical (approximate) certificate  $f = \sum g_i^2$  (via SDP software, say), can we find an exact decomposition of  $f$  in  $\sum \mathbb{Q}[X]^2$ ? Recent approaches using hybrid symbolic-numeric approaches are very promising.

Peyrl and Parrilo [42] give an algorithm for converting a numerical sos decomposition into an exact certificate, in some cases. The idea: Given  $f \in \sum \mathbb{Q}[X]^2$ , we want to find a symmetric psd matrix  $\mathcal{A}$  with rational entries so that

$$f = V \cdot \mathcal{A} \cdot V^T \tag{3}$$

The SDP software will produce a psd matrix  $A$  which only *approximately* satisfies (3). The idea is to project  $A$  onto the affine space of solutions to (3) in such a way that the projection remains in the cone of psd symmetric matrices. The Peyrl-Parrilo method is (theoretically!) guaranteed to work if there exists a rational solution and the underlying SDP is strictly feasible, i.e., there is a solution with full rank. Kalfoten, Li, Yang, and Zhi [24] have generalized the technique of Peyrl and Parrilo and used these ideas to find sos certificates certifying rational lower bounds for several well-known problems.

### 3.2 Certificates of positivity via Artin’s Theorem

Recall Artin’s solution to Hilbert’s 17th Problem which says that if  $f \in \mathbb{R}[X]$  is psd, then there exists nonzero  $g \in \mathbb{R}[X]$  such that  $g^2 f$  is sos. Recent work of Kalfoten, Li, Yang, and Zhi [23] turns Artin’s theorem into a symbolic-numeric algorithm for finding certificates of positivity for any psd  $f \in \mathbb{Q}[X]$ . The algorithm finds a numerical representation of  $f$  as a quotient  $g/h$ , where  $g$  and  $h$  are sos, and then converts this to an exact rational identity using techniques described above. The algorithm has been implemented as software called ArtinProver. Kalfoten, Yang, and Zhi have used this technique and the software to settle the dimension 4 case of the Monotone Column Permanent Conjecture, see [25].

### 3.3 Schmüdgen’s and Putinar’s theorems

Let  $G \subseteq \mathbb{R}[X]$  be a finite and suppose  $\mathcal{S} := \mathcal{S}(G)$  is compact. Set  $\mathcal{P} = PO(G)$ . Recall Schmüdgen’s Theorem says that every polynomial that is strictly positive on  $\mathcal{S}$  is in  $\mathcal{P}$ , regardless of the choice of generating polynomials  $G$ . Schmüdgen’s proof uses functional analytic methods and is not constructive in the sense that no information is given concerning how to find an explicit certificate of positivity in  $\mathcal{P}$  for a given  $f$  which is strictly positive on  $\mathcal{S}$ .

### 3.3.1 Algorithmic Schmüdgen Theorem

In 2002, Schweighofer [76] gave a proof of Schmüdgen’s Theorem which is algorithmic, apart from an application of the Classical Positivstellensatz. The idea of the proof is to reduce to Pólya’s Theorem (in a larger number of variables). The Classical Positivstellensatz is used to imply the existence of a “certificate of compactness” for  $\mathcal{S}$ , i.e., the existence of  $s, t \in \mathcal{P}$  and  $r \in \mathbb{R}$  such that

$$s(r^2 - \sum X_i^2) = 1 + t \tag{4}$$

### 3.3.2 Degree bounds for Schmüdgen Theorem

Unlike the global (sum of squares) case, in general, there is no bound on the degree of the sums of squares in a representation of  $f$  in  $\mathcal{P}$  in terms of the degree of  $f$  only. This has obvious implications for applications of Schmüdgen’s Theorem, for example in recent work on the approximation of polynomial optimization problems via semidefinite programming. Using model and valuation theoretic methods, Prestel [58, Theorem 8.3.4] showed that there exists a bound on the degree of the sums of squares which depends on three parameters, namely, the polynomials  $G$  used to define  $\mathcal{S}$ , the degree of  $f$ , and a measure of how close  $f$  is to having a zero on  $\mathcal{S}$ . Schweighofer [77] used his algorithmic proof of the result to give a bound on the degree of the sums of squares in a representation of  $f$  in  $\mathcal{P}$ . Roughly speaking, the bound makes explicit the dependence on the second and third parameter in Prestel’s theorem. The first parameter appears in the bound as a constant, which depends only on the polynomials  $G$ , and which comes from the compactness certificate (4). The exact result is as follows:

**Theorem 14** ([77], Theorem 3). *Let  $G = \{g_1, \dots, g_k\}$ ,  $\mathcal{S}$ , and  $\mathcal{P}$  be as above and suppose  $\mathcal{S} \subseteq (-1, 1)^n$ . Then there exists  $c \in \mathbb{N}$  so that for every  $f \in \mathbb{R}[X]$  of degree  $d$  with  $f > 0$  on  $\mathcal{S}$  and  $f^* = \min\{g(x) \mid x \in \mathcal{S}\}$ ,*

$$f = \sum_{e \in \{0,1\}^k} s_e g_1^{e_1} \dots g_k^{e_k},$$

where  $s_e \in \sum \mathbb{R}[X]^2$  and  $s_e = 0$  or

$$\deg(s_e g_1^{e_1} \dots g_k^{e_k}) \leq cd^2 \left( 1 + \left( d^2 n^d \frac{\|f\|}{f^*} \right)^c \right).$$

Here  $\|f\|$  is a measure of the size of the coefficients of  $f$ . The constant  $c$  depends on the polynomials  $G$  in an unspecified way, however in concrete cases one could (in theory!) obtain an explicit  $c$  from the proof of the theorem.

### 3.3.3 Putinar’s Theorem

Let  $G$  and  $\mathcal{S}$  be as above and set  $M = M(G)$ . Recall Putinar’s Theorem says that if  $M$  is archimedean, then every  $f > 0$  on  $\mathcal{S}$  is in  $M$ . Again, Putinar’s proof is functional analytic and does not show how to find an explicit certificate of positivity for  $f$  in  $M$ . In [78], Schweighofer extends the algorithmic proof of Schmüdgen’s Theorem to give an algorithmic proof of Putinar’s Theorem. Nie and Schweighofer [40] then use this proof to give a bound for the degree of the sums of squares in a representation, similar to Theorem 14. Recently, Putinar’s Theorem has been used by Lasserre to give an algorithm for approximating the minimum of a polynomial on a compact basic closed semialgebraic set, see [29]. The results in [40] yields information about the convergence rate of the Lasserre method.

### 3.4 Rational certificates of positivity

In §3.1, an algorithm for finding sum of squares certificates of positivity for sos polynomials  $f$  is described, using semidefinite programming. This technique can also be used to find certificates of positivity for a polynomial  $f$  which is positive on a compact semialgebraic set. However, there is another question which arises when we are using numerical software: All polynomials found in a certificate of positivity, for example in the sums of squares, will have rational coefficients. But do we know that such a certificate exists, even if we start with  $f \in \mathbb{Q}[X]$ ?

#### 3.4.1 Sums of squares of rational polynomials

Sturmfels asked the following question: Suppose  $f \in \mathbb{Q}[X]$  is in  $\sum \mathbb{R}[X]^2$ , is  $f \in \sum \mathbb{Q}[X]^2$ ? Here is a trivial, but illustrative example: The rational polynomial  $2x^2$  is a square, since  $2x^2 = (\sqrt{2}x)^2$ . But  $2x^2$  is also in  $\sum \mathbb{Q}[x]^2$  since  $2x^2 = x^2 + x^2$ . Less trivially, recall the Hillar example:

$$f = 3 - 12y - 6x^3 + 18y^2 + 3x^6 + 12x^3y - 6xy^3 + 6x^2y^4,$$

as noted above,  $f$  is a sum of three squares in  $\mathbb{R}[x, y]$ . It turns out that  $f$  is a sum of six squares in  $\mathbb{Q}[x, y]$ :

$$f = (x^3 + xy^2 + \frac{3}{2}y - 1)^2 + (x^3 + 2y - 1)^2 + (x^3 - xy^2 + \frac{5}{2}y - 1)^2 + (2y - xy^2)^2 + \frac{3}{2}y^2 + 3x^2y^4.$$

The answer to Sturmfel’s question is not known in general, however there are partial results. In the univariate case, the answer is “yes”; proofs have been given by Landau [28] and Schweighofer [75]. Porchet [48] showed that at most five squares are needed. Hillar [21] showed that the answer to Sturmfel’s question is “yes” if  $f \in \sum K^2$ , where  $K$  is a totally real extension

of  $\mathbb{Q}$ , and he gave bounds for the number of squares needed. There is a simple proof of a slightly more general result with a better bound given (independently) by Scheiderer [65] and Quarez [60].

**Remark 1.** The proof of Artin’s Theorem shows immediately that if  $f \in \mathbb{Q}[X]$  is psd, then there always exist  $g, h \in \sum \mathbb{Q}[X]^2$  such that  $f = g/h$ . The rationality question is not an issue in this case.

### 3.4.2 Rational certificates of positivity on compact sets

There is an obvious analog of Sturmfels’ question for the case of polynomials positive on compact semialgebraic sets. Let  $\mathcal{P} = PO(G)$  for finite  $G \subseteq \mathbb{Q}[X]$ . If  $f \in \mathbb{Q}[X]$  is in  $\mathcal{P}$ , does there exist a representation of  $f$  in  $\mathcal{P}$  such that the sums of squares that occur are in  $\sum \mathbb{Q}[X]^2$ ? We can ask a similar question for the quadratic module  $M(G)$ . In [49], it is shown that the answer is “yes” for  $\mathcal{P}$  in the compact case and “yes” for  $M$  with an additional assumption.

**Theorem 15.** *Let  $G = \{g_1, \dots, g_r\} \subseteq \mathbb{Q}[X]$  and suppose  $\mathcal{S} = \mathcal{S}(G)$  is compact. Let  $\mathcal{P} = PO(G)$  and  $M = M(G)$ . Given  $f \in \mathbb{Q}[X]$  such that  $f > 0$  on  $\mathcal{S}$ , then*

1. *There is a representation of  $f$  in the preordering  $\mathcal{P}$ ,*

$$f = \sum_{e \in \{0,1\}^r} \sigma_e g_1^{e_1} \dots g_r^{e_r},$$

*with all  $\sigma_e \in \sum \mathbb{Q}[X]^2$ .*

2. *There is a rational representation of  $f$  in  $M$  provided one of the generators is  $N - \sum X_i^2$ . More precisely, there exist  $\sigma_0 \dots \sigma_s, \sigma \in \sum \mathbb{Q}[X]^2$  and  $N \in \mathbb{N}$  so that*

$$f = \sigma_0 + \sigma_1 g_1 + \dots + \sigma_s g_s + \sigma(N - \sum X_i^2).$$

The proof of the first part follows from an algebraic proof of Schmüdgen’s Theorem, due to T. Wörmann, which uses the Abstract Positivstellensatz. Wörmann’s proof can be found in [5] or [58, Thm. 5.1.17]. The second part follows from Schweighofer’s algorithmic proof of Putinar’s Theorem.

### 3.5 Certificates of positivity using Bernstein’s and Pólya’s theorems

Using Bernstein’s Theorem and Pólya’s Theorem, certificates of positivity for polynomials positive on simplices can be obtained. Furthermore, this approach yields degree bounds for the certificates and, in some cases, practical algorithms for finding certificates.

**3.5.1 The univariate case**

For  $k \in \mathbb{N}$ , define in  $\mathbb{R}[x]$ :

$$\mathcal{B}_k := \left\{ \sum_{i+j \leq k} c_{ij}(1-x)^i(1+x)^j \mid c_{ij} \geq 0 \right\}.$$

Suppose a univariate  $p \in \mathbb{R}[x]$  is strictly positive on  $[-1, 1]$ , then Bernstein's Theorem says that there is some  $r = r(p)$  such that  $p \in \mathcal{B}_r$ . Suppose  $p \in \mathbb{R}[x]$  has degree  $d$ , then let  $\tilde{p}$  denote the Goursat transform applied to  $p$ , i.e.,

$$\tilde{p}(x) = (1+x)^d p\left(\frac{1-x}{1+x}\right).$$

Powers and Reznick gave a bound on  $r(p)$  in terms of the minimum of  $p$  on  $[-1, 1]$  and size of the coefficients of  $\tilde{p}$ , which in turn yields a bound for the size of a certificate of positivity for  $p$ .

More recently, F. Boudaoud, F. Caruso, and M.-F. Roy [7] obtain a local version of Bernstein's Theorem which yields a better bound. They show that if  $\deg p = d$  and  $p > 0$  on  $[-1, 1]$ , then there exists a subdivision  $-1 = y_1 < \dots < y_t = 1$  of  $[-1, 1]$  such that Bernstein-like certificates of positivity for  $p$  can be obtained on each interval  $[y_i, y_{i+1}]$ . This yields a certificate of positivity for  $p$  on  $[-1, 1]$  of bit-size  $O((d^4(\tau + \log_2 d)))$ , where  $d = \deg p$  and the coefficients of  $p$  have bit-size  $\leq \tau$ . Moreover, their result holds with  $\mathbb{R}$  replaced by any real-closed field, which is not true for Bernstein's Theorem.

**3.5.2 Polynomials positive on a simplex**

Recall that Pólya's Theorem says that if a form (homogeneous polynomial)  $f$  is strictly positive on the standard simplex  $\Delta_n := \{x \in \mathbb{R}^n \mid x_i \geq 0 \text{ for all } i \text{ and } \sum x_i = 1\}$ , then for sufficiently large  $N \in \mathbb{N}$ , all coefficients of  $(\sum X_i)^N f$  are strictly positive. Powers and Reznick [51] gave a bound on  $N$ , in terms of the degree of  $f$ , the minimum of  $f$  on  $\Delta_n$ , and the size of the coefficients. This result has been used in several applications, for example the algorithmic proof of Schmüdgen's theorem given by Schweighofer discussed in §3.3.1. Also, de Klerk and Pasechnik [16] used it to give results on approximating the stability number of a graph.

In theory, the bound for Pólya's Theorem could be used to obtain certificates of positivity on the simplex, however in practice the bounds require finding minimums of forms on closed subsets of the simplex and so are not of much practical use. Another, more feasible, approach to certificates of positivity for polynomials positive on a simplex, due to R. Leroy [32], uses the multivariable Bernstein polynomials and a generalization of the ideas in

[7]. The Bernstein polynomials are more suitable than the standard monomial basis in this case since this approach gives results for an arbitrary non-degenerate simplex and yields an algorithm for deciding positivity of a polynomial on a simplex. The idea is to subdivide the simplex and obtain local certificates so that the sizes of the local certificates are smaller than those of a global certificate.

Let  $V$  be a non-degenerate simplex in  $\mathbb{R}^n$ , i.e., the convex hull of  $n + 1$  affinely independent points  $v_0, v_1, \dots, v_n$  in  $\mathbb{R}^n$ . The barycentric coordinates of  $V$ ,  $\lambda_0, \dots, \lambda_n$ , are linear polynomials in  $\mathbb{R}[X]$  such that

$$\sum_{i=0}^n \lambda_i = 1, \quad (X_0, \dots, X_n) = \sum_{i=0}^n \lambda_i(X) v_i.$$

Then for  $d \in \mathbb{N}$ , the Bernstein polynomials of degree  $d$  with respect to  $V$  are  $\{B_\alpha^d \mid \alpha \in \mathbb{N}^{n+1}, |\alpha| = d\}$ , where

$$B_\alpha^d = \frac{d!}{\alpha_0! \alpha_1! \cdots \alpha_n!} \prod_{i=0}^n \lambda_i^{\alpha_i}.$$

They form a basis for the vector space of polynomials in  $\mathbb{R}[X]$  of degree  $\leq d$ , hence any  $f \in \mathbb{R}[X]$  of degree  $\leq d$  can be written uniquely as a linear combination of the  $B_\alpha^d$ 's. The coefficients are called the Bernstein coefficients of  $f$ . If  $f > 0$  on  $V$ , then for sufficiently large  $D$ , the Bernstein coefficients using the  $B_\alpha^D$ 's are nonnegative, which yields a certificate of positivity for  $f$  on  $V$ .

This can be made computationally feasible, as well as lead to an algorithm for deciding if  $f$  is positive on  $V$ . The idea is to triangulate  $V$  into smaller simplices and look for certificates of positivity on the sub-simplices. A stopping criterion is obtained using a lower bound on the minimum of a positive polynomial on  $V$ , in terms of the degree, the number of variables, and the bitsize of the coefficients. This was proven by S. Basu, Leroy, and Roy [2] and later improved by G. Jeronimo and D. Perrucci [22].

### 3.5.3 Pólya's Theorem with zeros

What can we say if the condition “strictly positive on  $\Delta_n$ ” in Pólya's Theorem is replaced by “nonnegative on  $\Delta_n$ ”? It is easy to see that in this case we must use a slightly relaxed version of Pólya's Theorem, replacing the condition of “strictly positive coefficients” by “nonnegative coefficients”. Let  $Po(n, d)$  be the set of forms of degree  $d$  in  $n$  variables for which there exists an  $N \in \mathbb{N}$  such that  $(X_1 + \cdots + X_n)^N p \in \mathbb{R}^+[X]$ . In other words,  $Po(n, d)$  are the forms which satisfy the conclusion of Pólya's Theorem, with “positive coefficients” replaced by “nonnegative coefficients.”



It is easy to see that  $p \in Po(n, d)$  implies  $p \geq 0$  on  $\Delta_n$  and that  $p > 0$  on the interior of  $\Delta_n$ . Further,  $Z(p)$ , the zero set of  $p$ , must be a union of faces of  $\Delta_n$ . Pólya's Theorem and the bound are generalized to forms that are positive on the simplex apart from zeros on the corners (zero dimensional faces) of  $\Delta_n$ , in papers by Powers and Reznick [53] and M. Castle, Powers, and Reznick [10]. See also work by H.-N. Mok and W.-K. To [35], who give a sufficient condition for a form to satisfy the relaxed version of Pólya's Theorem, along with a bound in this case.

Very recently, Castle, Powers, and Reznick [9] give a complete characterization of forms that are in  $Po(n, d)$  along with a recursive bound for the  $N$  needed. Before stating the main theorem of [9], we need a few definitions.

**Definition 2.** Let  $\alpha = (\alpha_1, \dots, \alpha_n), \beta = (\beta_1, \dots, \beta_n)$  be in  $\mathbb{N}^n$ .

1. We write  $\alpha \preceq \beta$  if  $\alpha_i \leq \beta_i$  for all  $i$ , and  $\alpha \prec \beta$  if  $\alpha \preceq \beta$  and  $\alpha \neq \beta$ .
2. Suppose  $F$  is a face of  $\Delta_n$ , say  $F = \{(x_1, \dots, x_n) \in \Delta_n \mid x_i = 0 \text{ for } i \in I\}$  for some  $I \subseteq \{1, 2, \dots, n\}$ . Then we denote by  $\alpha_F$  the vector  $(\tilde{\alpha}_1, \dots, \tilde{\alpha}_n) \in \mathbb{N}^n$ , where  $\tilde{\alpha}_i = \alpha_i$  for  $i \in I$  and  $\tilde{\alpha}_j = 0$  for  $j \notin I$ .
3. For a form  $p \in \mathbb{R}[X]$ , let  $\Lambda^+(p)$  denote the exponents of  $p$  with positive coefficients and  $\Lambda^-(p)$  the exponents of  $p$  with negative coefficients.
4. For a face  $F$  of  $\Delta_n$  and a subset  $S \subseteq \mathbb{N}$ , we say that  $\alpha \in S$  is *minimal in  $S$  with respect to  $F$*  if there is no  $\gamma \in S$  such that  $\gamma_F \prec \alpha_F$ .

**Theorem 16.** Given  $p = \sum a_\beta X^\beta$ , a nonzero form of degree  $d$ , such that  $p \geq 0$  on  $\Delta_n$  and  $Z(p) \cap \Delta_n$  is a union of faces. Let  $\Lambda^+(p)$  denote the exponents of  $p$  with positive coefficients and  $\Lambda^-(p)$  the exponents of  $p$  with negative coefficients. Then  $p \in Po(n, d)$  if and only if for every face  $F \subseteq Z(p)$  the following two conditions hold:

1. For every  $\beta \in \Lambda^-(p)$ , there is  $\alpha \in \Lambda^+(p)$  so that  $\alpha_F \preceq \beta_F$ .
2. For every  $\alpha \in \Lambda^+(p)$  which is minimal on  $\Lambda^+(p)$  with respect to  $F$ , the form  $\sum_{\{\gamma \in \text{supp}(p) \mid \gamma_F = \alpha_F\}} a_\gamma X^{\gamma - \alpha_F}$  is strictly positive on the relative interior of  $F$ .

### 3.5.4 Certificates of positivity on the hypercube

Finally, we mention briefly some recent work by de Klerk and Laurent [15] concerning polynomials positive on a hypercube  $Q = [0, 1]^n$ . Using Bernstein approximations, they obtain bounds for certificates of positivity for a polynomial  $f$  which is strictly positive on  $Q$ , in terms of the degree of  $f$ , the size of the coefficients, and the minimum of  $f$  on  $Q$ . They also give lower bounds, and sharper bounds in the case where  $f$  is quadratic.

### 3.6 Psd ternary quartics

Recall Hilbert's 1888 theorem that says every psd ternary quartic (homogeneous polynomial of degree 4 in 3 variables) is a sum of three squares of quadratic forms. Hilbert's proof is non-constructive in the sense that it gives no information about the following questions: Given a psd ternary quartic, how can one find three such quadratic forms? How many "fundamentally different" ways can this be done?

Several recent works have addressed these issues. In [50], Powers and Reznick describe methods for finding and counting representations of a psd ternary quartic and answer these questions completely for some special cases. In several examples, it was found that there are exactly 63 inequivalent representations as a sum of three squares of complex quadratic forms and, of these, 8 correspond to representations as a sum of squares of real quadratic forms. By "inequivalent representations" we mean up to orthogonal equivalence; two representations are equivalent iff they have the same Gram matrix (see §3.1).

The fact that a psd ternary quartic  $f$  has 63 inequivalent representations as a sum of squares of complex quadratic forms is a result due to Coble [14]. In 2004, Powers, Reznick, Scheiderer, and Sottile [54] showed that for every real psd ternary quartic  $f$  such that the complex plane curve  $Q$  defined by  $f = 0$  is smooth, exactly 8 of the 63 inequivalent representations correspond to a sum of three squares of real quadratic forms. More recently, in [71], Scheiderer extends this analysis to the singular case and computes the number of representations, depending on the configuration of the singular points. For example, if  $f$  is a psd singular ternary quartic and  $Q$  has a real double point, then there are exactly four inequivalent representations of  $f$  as a sum of three quadratic forms.

The elementary proof of Hilbert's Theorem on ternary quartics in [44] is constructive in some sense. The authors state: "It should be possible to follow our deformation argument for constructing such representations with arbitrary numeric precision, for example by using finite element methods." Furthermore, their arguments give information on the number of inequivalent representations. In particular, this yields a new, elementary proof of the fact that for a generically chosen psd ternary quartic  $f$ , there are exactly 8 inequivalent representations and when  $f$  is generically chosen with a real zero, there are 4 inequivalent representations.

Finally, we mention very recent work on quartic curves due to Plaumann, Sturmfels, and Vinzant [46]. They give a new proof of the Coble result which yields an algorithm for computing all representations of a smooth ternary quartic as a sum of squares of three complex quadratic forms.

## References

- [1] E. Artin, *Über die Zerlegung definiter Funktionen in Quadrate*, Abh. Math. Sem. Univ. Hamburg **5** (1927), 85–99.
- [2] S. Basu, R. Leroy, and M.-F. Roy, *A bound on the minimum of a real positive polynomial over the standard simplex*, preprint.
- [3] C. Berg and P. H. Maserick, *Polynomially positive definite sequences*, Math. Ann. **259** (1982), 487–495.
- [4] S. Bernstein, *Sur la représentation des polynômes positif*, Soobshch. Har’k. Mat. Obshch. **2** (1915), no. 14, 227–228.
- [5] R. Berr and T. Wörmann, *Positive polynomials on compact sets*, Manuscripta Math. **104** (2001), no. 2, 135–143. MR 1821179 (2002a:14061)
- [6] G. Blekherman, *Nonnegative polynomials and sums of squares*, preprint.
- [7] F. Boudaoud, F. Caruso, and M.-F. Roy, *Certificates of positivity in the Bernstein basis*, Discrete Comput. Geom. **39** (2008), no. 4, 639–655. MR 2413151 (2009b:13064)
- [8] S. Burgdorf, C. Scheiderer, and M. Schweighofer, *Pure states, nonnegative polynomials, and sums of squares*, Comm. Math. Helvetici, to appear.
- [9] M. Castle, V. Powers, and B. Reznick, *Pólya’s theorem with zeros*, J. Symb. Comput., to appear.
- [10] ———, *A quantitative Pólya’s theorem with zeros*, J. Symb. Comput. **44** (2009), no. 9, 1285–1290. MR 2532172 (2010d:13029)
- [11] M. D. Choi and T. Y. Lam, *An old question of Hilbert*, Conference on Quadratic Forms—1976 (Proc. Conf., Queen’s Univ., Kingston, Ont., 1976), Queen’s Univ., Kingston, Ont., 1977, pp. 385–405. Queen’s Papers in Pure and Appl. Math., No. 46. MR 0498375 (58 #16503)
- [12] M. D. Choi, T. Y. Lam, and B. Reznick, *Sums of squares of real polynomials*, Proceedings of Symposia in Pure Mathematics **58** (1995), no. 2, 103–126.
- [13] J. Cimpric, S. Kuhlmann, and C. Scheiderer, *Sums of squares and moment problems in equivariant situations*, Trans. Amer. Math. Soc **361** (2009), 735–765.

- [14] A. Coble, *Algebraic geometry and theta functions*, Colloquium Publications, vol. 10, Amer. Math. Soc., 1929.
- [15] E. de Klerk and M. Laurent, *Error bounds for some semidefinite programming approaches to polynomial minimization on the hypercube*, SIAM J. Optim. **20** (2010), no. 6, 3104–3120. MR 2735946
- [16] E. de Klerk and D. V. Pasechnik, *Approximation of the stability number of a graph via copositive programming*, SIAM Journal on Optimization **12** (2002), no. 4, 875–892.
- [17] K. Gatermann and P. Parrilo, *Symmetry groups, semidefinite programs, and sums of squares*, Journal of Pure and Applied Algebra **192** (2004), no. 1-3, 95 – 128.
- [18] D. Grimm, T. Netzer, and M. Schweighofer, *A note on the representation of positive polynomials with structured sparsity*, Arch. Math. (Basel) **89** (2007), no. 5, 399–403. MR 2363690 (2008i:13040)
- [19] F. Hausdorff, *Summationsmethoden und Momentfolgen. I*, Math. Z. **9** (1921), no. 1-2, 74–109. MR 1544453
- [20] D. Hilbert, *Über die Darstellung definiter Funktionen durch Quadrate*, Math. Ann. **32** (1888), 342–350.
- [21] C. Hillar, *Sums of squares over totally real fields are rational sums of squares*, Proc. Amer. Math. Soc. **137** (2009), no. 3, 921–930. MR 2457431 (2009h:12009)
- [22] G. Jeronimo and D. Perrucci, *On the minimum of a positive polynomial over the standard simplex*, preprint.
- [23] E. Kaltofen, B. Li, Z. Yang, and L. Zhi, *Exact certification in global polynomial optimization via sums-of-squares of rational functions with rational coefficients*, preprint.
- [24] ———, *Exact certification of global optimality of approximate factorizations via rationalizing sums-of-squares with floating point scalars*, Proceedings of the twenty-first international symposium on Symbolic and algebraic computation (New York, NY, USA), ISSAC '08, ACM, 2008, pp. 155–164.
- [25] E. Kaltofen, Y. Yang, and L. Zhi, *A proof of the monotone column permanent (mcp) conjecture for dimension 4 via sums-of-squares of rational functions.*, SNC'09 Proc. 2009 Internat. Workshop on Symbolic-Numeric Comput. (New York, NY) (H. Kai and H. Sekigawa, eds.), ACM, 2009, pp. 65–69.

- [26] M. Kojima and M. Muramatsu, *A note on sparse SOS and SDP relaxations for polynomial optimization problems over symmetric cones*, *Comput. Optim. Appl.* **42** (2009), 31–41.
- [27] S. Kuhlmann and M. Marshall, *Positivity, sums of squares and the multidimensional moment problem*, *Transactions AMS* **354** (2002), 4285–4301.
- [28] E. Landau, *Über die Darstellung definiter Funktionen durch Quadrate*, *Math. Ann.* **62** (1906), no. 2, 272–285. MR 1511376
- [29] J. B. Lasserre, *Global optimization with polynomials and the problem of moments*, *SIAM J. Optim.* **11** (2000/01), no. 3, 796–817 (electronic). MR 1814045 (2002b:90054)
- [30] ———, *Convergent SDP-relaxations in polynomial optimization with sparsity*, *SIAM J. Optim.* **17** (2006), no. 3, 822–843 (electronic). MR 2257211 (2007h:90046)
- [31] M. Laurent, *Sums of squares, moment matrices and optimization over polynomials*, *Emerging Applications of Algebraic Geometry*, IMA Vol. Math. Appl., vol. 149, Springer, New York, 2009, pp. 157–270. MR 2500468 (2010j:13054)
- [32] R. Leroy, *Certificates of positivity in the simplicial Bernstein basis*, preprint.
- [33] M. Marshall, *Positive Polynomials and Sums of Squares*, *Mathematical Surveys and Monographs*, vol. 146, American Mathematical Society, Providence, RI, 2008. MR 2383959 (2009a:13044)
- [34] ———, *Polynomials non-negative on a strip*, *Proceedings AMS* **138** (2010), 1559–1567.
- [35] H.-N. Mok and W.-K. To, *Effective Pólya semi-positivity for non-negative polynomials on the simplex*, *J. Complexity* **24** (2008), no. 4, 524–544. MR 2432103 (2010f:14064)
- [36] T. Netzer, *Stability of quadratic modules*, *Manuscripta Math.* **129** (2009), no. 2, 251–271. MR 2505804 (2010m:13035)
- [37] H. Nguyen, *Polynomials non-negative on non-compact subsets of the plane*, Ph.D. thesis, Emory University, 2010.
- [38] H. Nguyen and V. Powers, *Polynomials non-negative on a strip*, preprint.

- [39] J. Nie, K. Ranestad, and B. Sturmfels, *The algebraic degree of semidefinite programming*, Mathematical Programming **122** (2010), 379–405, 10.1007/s10107-008-0253-6.
- [40] J. Nie and M. Schweighofer, *On the complexity of Putinar’s Positivstellensatz*, Journal of Complexity **23** (2007), no. 1, 135 – 150.
- [41] P. Parrilo and B. Sturmfels, *Minimizing polynomial functions*, Algorithmic and Quantitative Real Algebraic Geometry (S. Basu and L. Gonzalez-Vega, eds.), DIMACS series in Discrete Mathematics and Theoretical Computer Science, vol. 60, American Mathematical Society, Providence, RI, 2003, pp. 83–99.
- [42] H. Peyrl and P. Parrilo, *Computing sum of squares decompositions with rational coefficients*, Theoretical Computer Science **409** (2008), no. 2, 269 – 281, Symbolic-Numerical Computations.
- [43] A. Pfister, *On Hilbert’s theorem about ternary quartics*, Algebraic and Arithmetic Theory of Quadratic Forms, Contemp. Math., vol. 344, Amer. Math. Soc., Providence, RI, 2004, pp. 295–301.
- [44] A. Pfister and C. Scheiderer, *An elementary proof of Hilbert’s theorem on ternary quartics*, preprint, 2010.
- [45] D. Plaumann, *Sums of squares on reducible real curves*, Mathematische Zeitschrift **265** (2010), 777–797, 10.1007/s00209-009-0541-8.
- [46] D. Plaumann, B. Sturmfels, and C. Vinzant, *Quartic curves and their bitangents*, J. Symbolic Computation **46** (2011), 712–733.
- [47] G. Pólya, *Über positive Darstellung von Polynomen*, Vierteljschr Naturforsch. Ges. Zürich **73** (1928), 141–145.
- [48] Y. Pourchet, *Sur la représentation en somme de carrés des polynômes à une indéterminée sur un corps de nombres algébriques*, Acta Arith. **19** (1971), 89–104. MR 0289442 (44 #6632)
- [49] V. Powers, *Rational certificates of positivity on compact semialgebraic sets*, *Pac. J. Math.*, to appear.
- [50] V. Powers and B. Reznick, *Notes towards a constructive proof of Hilbert’s theorem on ternary quartics*, Quadratic forms and their applications (Dublin, 1999), Contemp. Math., vol. 272, Amer. Math. Soc., Providence, RI, 2000, pp. 209–227.
- [51] ———, *A new bound for Pólya’s theorem with applications to polynomials positive on polyhedra*, J. Pure Appl. Algebra **164** (2001), no. 1-2, 221–229, Effective methods in algebraic geometry (Bath, 2000). MR 1854339 (2002g:14087)

- [52] ———, *Polynomials positive on unbounded rectangles*, Positive polynomials in control, Lecture Notes in Control and Inform. Sci., vol. 312, Springer, 2005, pp. 151–163.
- [53] ———, *A quantitative Pólya's theorem with corner zeros*, ISSAC 2006, ACM, New York, 2006, pp. 285–289. MR 2289132
- [54] V. Powers, B. Reznick, C. Scheiderer, and F. Sottile, *A new approach to Hilbert's theorem on ternary quartics*, C. R. Math. Acad. Sci. Paris **339** (2004), no. 9, 617–620. MR 2103198 (2005i:11051)
- [55] V. Powers and C. Scheiderer, *The moment problem for non-compact semialgebraic sets*, Adv. Geom. **1** (2001), no. 1, 71–88. MR 1823953 (2002c:14086)
- [56] V. Powers and T. Wörmann, *An algorithm for sums of squares of real polynomials*, J. Pure and Appl. Algebra **127** (1998), 99–104.
- [57] S. Prajna, A. Papachristodoulou, P. Seiler, and P.A. Parrilo, *SOS-TOOLS: Control applications and new developments*, Computer Aided Control Systems Design, 2004 IEEE International Symposium on, 2004, pp. 315–320.
- [58] A. Prestel and C. Delzell, *Positive polynomials*, Springer Monographs in Mathematics, Springer-Verlag, Berlin, 2001, From Hilbert's 17th problem to real algebra. MR 1829790 (2002k:13044)
- [59] M. Putinar, *Positive polynomials on compact semi-algebraic sets*, Indiana Univ. Math. J. **42** (1993), no. 3, 969–984. MR 1254128 (95h:47014)
- [60] R. Quarez, *Tight bounds for rational sums of squares over totally real fields*, Rend. Circ. Mat. Palermo (2) **59** (2010), no. 3, 377–388. MR 2745518
- [61] A. R. Rajwade, *Squares*, London Mathematical Society Lecture Note Series, vol. 171, Cambridge University Press, Cambridge, 1993.
- [62] B. Reznick, *On Hilbert's construction of positive polynomials*, preprint.
- [63] ———, *Some concrete aspects of Hilbert's 17th Problem*, Real algebraic geometry and ordered structures (Baton Rouge, LA, 1996), Contemp. Math., vol. 253, Amer. Math. Soc., Providence, RI, 2000, pp. 251–272. MR 1747589 (2001i:11042)
- [64] W. Rudin, *Sums of squares of polynomials*, Amer. Math. Monthly **107** (2000), no. 9, 813–821. MR 1792413 (2002c:12003)
- [65] C. Scheiderer, *A remark on descending sums of squares representations*, unpublished manuscript.

- [66] ———, *Sums of squares of regular functions on real algebraic varieties*, Transactions AMS **352** (1999), 1030–1069.
- [67] ———, *Sums of squares on real algebraic curves*, Math. Z. **245** (2003), no. 4, 725–760. MR 2020709 (2004k:14103)
- [68] ———, *Non-existence of degree bounds for weighted sums of squares representations*, J. Complexity **21** (2005), no. 6, 823–844. MR 2182447 (2006k:14117)
- [69] ———, *Sums of squares on real algebraic surfaces*, Manuscripta Math. **119** (2006), 395–410.
- [70] ———, *Positivity and sums of squares: A guide to recent results*, Emerging Applications of Algebraic Geometry, IMA Vol. Math. Appl., vol. 149, Springer, New York, 2009, pp. 271–324. MR 2500469 (2010h:14092)
- [71] ———, *Hilbert’s theorem on positive ternary quartics: a refined analysis*, J. Algebraic Geom. **19** (2010), no. 2, 285–333. MR 2580677 (2011c:14099)
- [72] Claus Scheiderer, *Weighted sums of squares in local rings and their completions, I*, Mathematische Zeitschrift **266** (2010), 1–19, 10.1007/s00209-009-0551-6.
- [73] ———, *Weighted sums of squares in local rings and their completions, II*, Math. Z. **266** (2010), no. 1, 21–42. MR 2670670
- [74] K. Schmüdgen, *The  $K$ -moment problem for compact semi-algebraic sets*, Math. Ann. **289** (1991), no. 2, 203–206. MR 1092173 (92b:44011)
- [75] M. Schweighofer, *Algorithmische Beweise für Nichtnegativ- und Positivstellensätze*, Master’s thesis, University of Passau, 1999.
- [76] ———, *An algorithmic approach to Schmüdgen’s Positivstellensatz*, Journal of Pure and Applied Algebra **166** (2002), no. 3, 307 – 319.
- [77] ———, *On the complexity of Schmüdgen’s Positivstellensatz*, Journal of Complexity **20** (2004), no. 4, 529 – 543.
- [78] ———, *Optimization of polynomials on compact semialgebraic sets*, SIAM J. Optim. **15** (2005), no. 3, 805–825 (electronic). MR 2142861 (2006d:90136)
- [79] Gilbert Stengle, *A Nullstellensatz and a Positivstellensatz in semialgebraic geometry*, Math. Ann. **207** (1974), 87–97. MR 0332747 (48 #11073)



- [80] R. G. Swan, *Hilbert's theorem on positive ternary quartics*, Quadratic forms and their applications (Dublin, 1999), Contemp. Math., vol. 272, Amer. Math. Soc., Providence, RI, 2000, pp. 287–292. MR 1803372 (2001k:11065)
- [81] T. Wörmann, *Strikt positive Polynome in der semialgebraischen Geometrie*, Ph.D. thesis, Univ. Dortmund, 1998.

## A SURVEY ON O-MINIMAL STRUCTURES

JEAN-PHILIPPE ROLIN

ABSTRACT. We analyze some aspects of the theory of o-minimal structures. In particular, we illustrate on various examples several analytic and geometric methods involved in the proofs of o-minimality.

The theory of o-minimal structures is a river that has several sources. A. Tarski and his monograph on the elementary theory of the structure  $(\mathbb{R}, +, \cdot)$  is obviously one of them [Tar51]. S. Lojasiewicz' work on semianalytic sets [Loj71], followed by with A. Gabrielov's celebrated theorem of the complement of a subanalytic set [Gab68], and subsequently by H. Hironaka's rectilinearization of subanalytic sets [Hir73], are undoubtedly another one. It is also worth mentioning the amazing title of the fifth section of A. Grothendieck's "Esquisse d'un programme": *Haro sur la topologie dite "générale", et réflexions heuristiques vers une topologie dite "modérée"*<sup>1</sup> [Gro97], from which the terminology "tame geometry", or "tame topology", comes.

The notion of o-minimal structure is introduced as such by L. van den Dries in [Dri84] (although the author does not speak of "o-minimal structures", but of "structure of finite type"). The terminology "o-minimal" appears in another seminal paper due to A. Pillay and C. Steinhorn [PS84], inspired by van den Dries' approach. This important topic, on the border between model theory and geometry, has been the subject of an impressive body of literature. Several excellent surveys and books are devoted to it. Let us mention van den Dries' book [Dri98], M. Coste's monograph [Cos00] and C. Miller's and van den Dries' article [DM96]. We should cite M. Shiota's book [Shi97], which develops the theory of  $\mathfrak{X}$ -sets, and contains the proof of several nice results.

The main purpose of this text is to extend the contents of the former surveys. We address in particular the questions asked in some of them. We also want to show that many proofs of o-minimality are based on common techniques, which generalize the well known method of quadratic blow-up transformations. Of course, our presentation is incomplete, and many interesting aspects are missing.

We assume some familiarity with the basic vocabulary of model theory (including the notions of *language, structures, theories, quantifier elimination, ...*).

## 1. THE INITIAL WORKS IN O-MINIMALITY

**1.1. Van den Dries' theories of finite type.** The article [Dri84] addresses the following question, asked by Tarski in his monograph on the elementary structure of  $(\mathbb{R}, +, \cdot)$ : *can we extend the results of [Tar51] to the structure  $(\mathbb{R}, +, \cdot, \exp)$* <sup>2</sup>?

<sup>1</sup>Denunciation of so-called "general" topology, and heuristic reflections towards a so-called "tame" topology.

<sup>2</sup>Actually, instead of  $\exp$ , Tarski suggests the function  $f: x \mapsto 2^x$ , which makes little difference since  $\exp$  is definable in  $(\mathbb{R}, +, \cdot, f)$ .

The central result of [Tar51] is the elimination of quantifiers for  $(\mathbb{R}, <, 0, 1, +, \cdot)$ . It implies quantifier elimination for the structure  $(\mathbb{R}, <, (a)_{a \in \mathbb{R}}, +, \cdot)$  and hence the so-called Tarski-Seidenberg theorem: the image of a semialgebraic subset of  $\mathbb{R}^m$  under a semialgebraic map from  $\mathbb{R}^m$  to  $\mathbb{R}^n$  is a semialgebraic subset of  $\mathbb{R}^n$ . It is well known that such a result is false for the elementary theory of  $(\mathbb{R}, <, (a)_{a \in \mathbb{R}}, +, \cdot, \exp)$ . This is illustrated by the following example, due to Osgood [Osg16]. Consider the function  $f$  defined on  $\mathbb{R} \times \mathbb{R}_{>0}$  by  $f(x, y) = y \cdot \exp(x/y)$ . Its graph

$$\Gamma(f) = \{(x, y, z) \in \mathbb{R}^3 : y > 0 \wedge \exists t (z = y \cdot \exp(t) \wedge ty = x)\}$$

is actually nothing but the cone, with vertex at the origin, on the plane analytic curve  $\{(x, 1, \exp(x)) : x \in \mathbb{R}\}^3$ . This set is definable in  $(\mathbb{R}, <, \cdot, \exp)$ . However, it can not be defined by a quantifier free formula in this language (see [Dri84, p. 100] for an proof of this last claim).

In order to go further with the investigation of Tarski’s problem despite the failure of “naive” quantifier elimination, van den Dries introduces in [Dri84] the following notion:

**Definition 1.1.** Let  $(A, <)$  be a nonempty dense linear order without endpoints, to which we add two “endpoints”  $-\infty$  and  $+\infty$  such that  $-\infty < a < +\infty$  for all  $a \in A$ . A subset  $X \subset A$  is called of *finite type* if  $X$  is the union of a finite set and finitely many intervals (an *interval* is a subset  $(a, b) = \{x \in A : a < x < b\}$ , where  $-\infty \leq a < b \leq +\infty$ ).

*Remark 1.2.* Obviously, if  $(A, <) = (\mathbb{R}, <)$ , then a set  $X \subset \mathbb{R}$  is of finite type if and only if  $X$  has finitely many connected components.

Given a first order language  $L$  with equality, and an  $L$ -structure  $\mathcal{A} = (A, \dots)$ , recall that an  $L$ -formula  $\varphi(v_1, \dots, v_n)$ ,  $n \geq 1$ , defines the set

$$\{(a_1, \dots, a_n) \in A^n : \mathcal{A} \models \varphi(v_1, \dots, v_n)\}$$

and that every set of this form is called a definable subset of  $A^n$ . A subset of  $A^n$  defined by a formula in the language  $L_A$  (with a constant symbol for each element of  $A$ ) is called  $A$ -definable (or *definable with parameters in  $A$* ).

Suppose that the language  $L$  contains a binary predicate symbol  $<$  and that the  $L$ -structure  $\mathcal{A} = (A, <, \dots)$  is an expansion of the dense linear ordering without endpoints  $(A, <)$ .

**Definition 1.3.** 1) An  $L$ -theory  $T$  (extending the theory of dense linear order without endpoints) is of *finite type* if each model  $\mathcal{A} = (A, <, \dots)$  of  $T$  has the property that each  $A$ -definable subset of  $A$  is of finite type.

2) A structure  $\mathcal{A} = (A, <, \dots)$  is of *finite type* if the theory  $\text{Th}(\mathcal{A})$  is of finite type.

*Remark 1.4.* It is interesting to notice the following intuitive comment of [Dri84, p. 106]: *if a structure  $\mathcal{A} = (A, <, \dots)$  is of finite type, then each  $A$ -definable subset of  $A$  is of finite type, but the converse is probably not valid.* Actually, the converse has been proved to be valid by J. Knight, A. Pillay and C. Steinhorn in [KPS86](see Section 1.2 of the present survey). Hence the familiar notion of *o-minimal structure*, that the reader may recognize in the former definitions, is given in [Dri84] in a pretty strong form (called *strong o-minimality* in [PS86]).

<sup>3</sup>We can remark the analogy with the construction of a subanalytic subset of  $\mathbb{R}^3$  which is not semianalytic.

The paper [Dri84] ends with a detailed investigation of the properties of the expansions  $\mathcal{R}$  of  $(\mathbb{R}, <)$  of finite type. In particular, the familiar notion of *cylindrical decomposition*, inspired by Collins’ proof of quantifier elimination for  $(\mathbb{R}, <, 0, 1, +, -)$  [Col75], is introduced on pp. 109-111, and the following famous theorem is proved:

**Theorem 1.5.** *Consider an expansion  $\mathcal{R}$  of  $(\mathbb{R}, <)$  of finite type. Let  $n \geq 1$ .*

- (1) *For each definable set  $X \subset \mathbb{R}^{n-1}$  and definable function  $f: X \rightarrow \mathbb{R}$  there is a finite partition of  $X$  into definable sets on each of which  $f$  is continuous.*
- (2) *Given any definable subsets  $A_1, \dots, A_m$  of  $\mathbb{R}^n$  there exists a cylindrical decomposition of  $\mathbb{R}^n$  partitioning each of  $A_1, \dots, A_m$ .*

*Remark 1.6.* 1) One can easily deduce from this result the fact that every definable set has finitely many connected components, and each component is also definable.

2) The relationship between “cylindrical decomposition” and “quantifier elimination” is recalled on p. 116: *if each quantifier free definable subset of  $\mathbb{R}^m$  has a quantifier free cylindrical decomposition, then  $Th(\mathcal{R})$  admits quantifier elimination.*

Let us conclude this section by quoting a few problems raised in [Dri84].

**1.** The paper is motivated by the conviction that the structure  $(\mathbb{R}, <, +, \cdot, \exp)$  is of finite type. An interesting line of attack is outlined on pp 101-102, consisting in inductively building a family of real analytic manifolds, each of which equipped with an algebra of real analytic functions. These collections of algebras should contain the exponential function, and be closed under certain classical operations, such as taking implicit functions. The delicate step, leading to finite type properties, is to show that, given a function which appears at some stage of the process, its zero-set is a disjoint union of finitely many manifolds built at previous stages. Actually, the idea of considering the properties of algebras of functions closed under “reasonable” operations turns out to be a rich intuition, which has been used since in several proofs of o-minimality. The o-minimality of the exponential structure itself has been proved by A. Wilkie in 1996 in the celebrated paper [Wil96].

**2.** The possible approach of Tarski’s question via quantifier elimination is a goal which has been achieved in the remarkable work of L. van den Dries, A. Macintyre and D. Marker in [DMM94]. They introduce the theory  $T_{\text{an}}(\exp)$  obtained by extending the theory  $T_{\text{an}}$  of restricted real analytic functions by a few axioms which express the classical properties of the exponential function. They then prove that this theory is complete, and that the theory  $T_{\text{an}}(\exp, \log)$  admits quantifier elimination (see Section 7.2 for an analysis of these methods). These results extend those obtained by L. van den Dries and C. Miller in [DM94] (in this paper, the o-minimality of  $(\mathbb{R}_{\text{an}}, \exp)$  is proved, via methods of Wilkie’s, as well as the analytic cell decomposition property).

**3.** The question (A10) of the appendix asks the following: let  $\mathcal{R}$  be an expansion of finite type of  $(\mathbb{R}, <, +, \cdot)$  and  $\varphi(v_1, \dots, v_{m+n})$  be an  $L_{\mathbb{R}}$ -formula. Does the family of  $\mathbb{R}$ -definable sets  $(X_a)_{a \in \mathbb{R}^m}$ , where  $X_a = \{b \in \mathbb{R}^n : \mathcal{R} \models \varphi(a, b)\}$ , have only finitely many homeomorphism types? A precise, positive, answer to this question is given in [Dri98, Chapter 9]. Let’s recall that a definable map  $f: S \subset \mathbb{R}^n \rightarrow A \subset \mathbb{R}^m$  is *definably trivial* if there exists a pair  $(F, \lambda)$  consisting of a definable set  $F \subset \mathbb{R}^N$  for some  $N$  and a definable map  $\lambda: S \rightarrow F$  such that  $(f, \lambda): S \rightarrow A \times F$  is a homeomorphism. Given a definable subset  $A' \subset A$  we call  $f$  *definably trivial over  $A'$*  if the restriction  $f|_{f^{-1}(A')}: f^{-1}(A') \rightarrow A'$  is definably trivial. We then have:

**Theorem 1.7.** *Let  $f: S \rightarrow A$  be a continuous definable map. Then there is a finite partition  $A = A_1 \cup \dots \cup A_M$  of  $A$  into definable sets  $A_i$  such that  $f$  is definably trivial over each  $A_i$ .*

This theorem answers question (A10) in the following way. Consider the definable set  $X = \{(a, b) \in \mathbb{R}^{m+n} : \mathcal{R} \models \varphi(a, b)\}$  and the projection map  $f: X \rightarrow \mathbb{R}^m$ . Take a partition of  $\mathbb{R}^m$  into definable sets  $A_1, \dots, A_M$  over which  $f$  is definably trivial, with definable trivialization  $(\lambda_i, F_i)$  over  $A_i$ . Then  $X_a$  is definably homeomorphic to  $F_i$  for all  $a \in A_i$ .

**1.2. Pillay’s and Steinhorn’s study of o-minimal structures.** A. Pillay and C. Steinhorn start in [PS86] a model theoretic investigation of o-minimal structures. Consider a first order language  $L$  which contains, among other things, a symbol  $<$ . Their study concerns with infinite  $L$ -structures  $M$  in which  $<$  represents a linear order of  $M$ .

**Definition 1.8.** 1) A linearly ordered structure  $M$  is *o-minimal* if every (parametrically) definable set  $X \subset M$  is a finite union of intervals of  $M$ .

2) An  $L$ -theory  $T$  is *strongly o-minimal* if every model of  $T$  is o-minimal.

We recognize in the point 2) of the above definition van den Dries’ notion of *theory of finite type*<sup>4</sup>. As a consequence of Tarski’s theorem, every real closed field is o-minimal. We have the following result:

**Proposition 1.9.** *Every o-minimal structure is definably complete: every parametrically definable subset of  $M$  that is bounded from above has a least upper bound in  $M$ .*

*Remark 1.10.* The converse is not true. For example, the structure  $(\mathbb{Q}, <, P)$  where  $P$  is a unary predicate interpreted as  $P = \{1/n : n \in \mathbb{N} \setminus \{0\}\}$  is definably complete but not o-minimal.

Another important result is :

**Theorem 1.11.** 1) *An ordered group  $G$  is o-minimal if and only if  $G$  is abelian and divisible.*

2) *An ordered ring  $R$  is o-minimal if and only if  $R$  is a real closed field.*

The following useful characterization of o-minimality is related to the notion of cut: a *cut*  $C$  in an ordered structure  $\mathcal{M}$  is a maximal consistent set of formulas with parameters from  $\mathcal{M}$  of the form  $m \leq x$  or  $x \leq m$  where  $m \in \mathcal{M}$ . We have:

**Theorem 1.12.** *Let  $\mathcal{M}$  be an linearly ordered structure. Then  $\mathcal{M}$  is o-minimal if and only if for each cut  $C$  in  $\mathcal{M}$ , there is a unique complete one-type with parameters from  $\mathcal{M}$  which extends  $C$ .*

A nice improvement of van den Dries’ approach is achieved in [KPS86]. Obviously, the notion of structure of finite type, which is clearly a property of a theory rather than of a structure, seems difficult to handle. The following result, proved by J. Knight, A. Pillay and C. Steinhorn, shows how to overcome this problem:

<sup>4</sup>Another source of inspiration for Pillay and Steinhorn is Baldwin’s and Lachlan’s work on strongly minimal theories [BL71]: a theory  $T$  is *strongly minimal* if all parametrically definable subsets in any model of  $T$  are finite or cofinite.

**Theorem 1.13.** *Consider an o-minimal structure  $M$  in which the underlying order is dense. Then:*

- (1) *Any definable subset of  $M^n$  is a disjoint union of finitely many definably connected definable sets (or connected definable sets if  $M$  is an expansion of  $(\mathbb{R}, <)$ ).*
- (2)  *$M$  is strongly o-minimal.*
- (3) *Let  $\varphi(x_1, \dots, x_n; y_1, \dots, y_m)$  be a formula of the language  $L$  (the language of  $M$ ). Then there exists  $K \in \mathbb{N}$  such that for every  $\bar{b} \in M^m$ , the set  $\{\bar{a} \in M^n : M \models \varphi(\bar{a}, \bar{b})\}$  has at most  $K$  definably connected components (connected components if  $M$  is an expansion of  $(\mathbb{R}, <)$ ).*

The proof of the first claim of the above theorem follows in outline that of van den Dries in [Dri84], who worked under the assumption of strong o-minimality, and the assumption that  $M$  expands  $(\mathbb{R}, <)$ .

A. Pillay and C. Steinhorn prove in [PS88] that an arbitrary o-minimal structure is strongly o-minimal for any (possibly non dense) linear order.

**1.3. Another survey: van den Dries, 1998.** Let us recall a few questions asked in van den Dries' survey [Dri99].

- (1) Is each o-minimal structure on the real field exponentially bounded?
- (2) Do all o-minimal structures on the real field have analytic cell decomposition? Same question with “analytic” replaced by “ $C^\infty$ ”.
- (3) Is there a largest o-minimal structure on the real field?

We cannot resist quoting the wise and funny comment added by van den Dries after these questions : *a positive answer to any of these questions would be too good to be true!* Actually, we can summarize the present knowledge about these problems:

- (1) No idea (but we agree with the above comment).
- (2) No, and no (see Sections 3 and 5)
- (3) No (see Section 3)

Van den Dries also asks the following questions, considered by him as “more open-ended”.

- (1) Does quasianalyticity imply o-minimality ?
- (2) Do the “analysable functions” in the sense of Ecalle [Éca92] generate an o-minimal structure on the real field ?

The answers today are :

- (1) Yes and no (one first has to define clearly what is exactly understood by quasianalyticity, see section 3).
- (2) Well ... no idea, as long as the exact definition of analysable function is still far to be clear. But some progress in this direction have been made (see Section 6).

We explain our answers in the next sections. As the blowing-up method plays such an important role in several polynomially bounded examples, we have decided to discuss it in detail.

## 2. BLOWING-UPS AND GENERALIZED POWER SERIES

The papers [DS98] and [DS00] written by L. van den Dries and P. Speissegger illustrate perfectly the following principle : *o-minimality (on the reals) is nothing but real analytic geometry based on algebras of non-analytic functions.* They consider

two expansions of the real field, and prove their o-minimality, model completeness and polynomial boundedness. More precisely, they show how a convenient blow-up process leads to a situation very similar to the starting point of the proof of Gabrielov’s theorem of the complement. This method became very familiar: o-minimality appears now in many examples as a consequence of model-completeness rather than quantifier elimination, which seems hard to obtain in general<sup>5</sup>.

We consider in this section the structure analyzed in [DS98]. If  $X = (X_1, \dots, X_m)$  denotes a tuple of  $m$  indeterminates, we consider the  $\mathbb{R}$ -algebra  $\mathbb{R}[[X^*]]$  of formal power series

$$F = F(X) = \sum_{\alpha} c_{\alpha} X^{\alpha}$$

where the multi-index  $\alpha = (\alpha_1, \dots, \alpha_m)$  ranges over  $[0, \infty)^m$ , with real coefficients  $c_{\alpha}$ , and  $X^{\alpha} := X_1^{\alpha_1} \cdots X_m^{\alpha_m}$ , and the set

$$\text{supp}(F) = \{\alpha \in [0, \infty)^m : c_{\alpha} \neq 0\}$$

is contained in a cartesian product  $S_1 \times \cdots \times S_m$  of *well ordered* subsets of  $[0, \infty)$ . Moreover, for each polyradius  $r = (r_1, \dots, r_m) \in (0, \infty)^m$  we let  $\mathbb{R}\{X^*\}_r$  be the subalgebra of  $\mathbb{R}[[X^*]]$  consisting of the  $F$ ’s such that

$$\|F\|_r = \sum_{\alpha} |c_{\alpha}| r^{\alpha} < \infty.$$

Each  $F(X) = \sum c_{\alpha} X^{\alpha} \in \mathbb{R}\{X^*\}_r$  gives rise to a continuous function  $x \mapsto F(x) = \sum c_{\alpha} x^{\alpha} : [0, r_1] \times \cdots \times [0, r_m] \rightarrow \mathbb{R}$ , which is analytic on  $(0, r_1) \times \cdots \times (0, r_m)$ . Let  $\mathbb{R}_{\text{an}*}$  be the expansion of the reals by all functions  $f : \mathbb{R}^m \rightarrow \mathbb{R}$ ,  $m \in \mathbb{N}$ , that are 0 outside  $[0, 1]^m$  and are given on  $[0, 1]^m$  by a power series  $F \in \mathbb{R}\{X^*\}_r$  for some polyradius  $r$  with  $r_1 > 1, \dots, r_m > 1$ . Then we have:

**Theorem 2.1.** *The expansion  $\mathbb{R}_{\text{an}*}$  is o-minimal, model complete and polynomially bounded.*

We first give an overview of the blow-up process involved. Then we recall the statement which generalizes in this framework (and many others) the usual theorem of the complement.

**2.1. Blowing-ups for generalized power series.** Even if we work with series with real exponents, the general idea follows the analysis of the classical Newton polyhedron of a given generalized series. Simplifying this Newton polyhedron via blow-up transforms is a classical tool in analytic geometry. Here, “simplifying” actually means several different things:

- (1) After a convenient blowing-up, an indeterminate with real exponents becomes an indeterminate with integer exponents.
- (2) After a convenient blowing-up, the series is “closer” to be a *normal series* (that is, a series equal to the product of a monomial and a unit).
- (3) If a series has at least two variables  $X_1$  and  $X_2$  with integer exponents (and hence defines a function which is *analytic* in these variables [DS98, Lemma 6.5]), a linear change of coordinates leads to a series which is *regular* in one of these variables. Hence, we can apply *Weierstrass’ preparation* with respect to this variable [DS98, Prop. 5.10].

<sup>5</sup>Let us mention nevertheless J. Denef’s and L. van den Dries’ proof of Gabrielov’s theorem of the complement via quantifier elimination in [DD88].

In order to “get rid” of variables with real exponents, the idea is to work with a ring  $A$  and to define as above the  $A$ -algebra  $A[[X^*]]$  of generalized formal power series with coefficients in  $A$ . In the following,  $A$  will be understood to be the ring of *classical* formal power series  $\mathbb{R}[[Y]]$  in the tuple of variables  $Y = (Y_1, \dots, Y_n)$ .

In order to give an idea of this process, consider a finite collection  $\mathcal{F} \subset A[[X^*]]$  of generalized power series. The *minimal monomials* of  $\mathcal{F}$  are the minimal monomials (ordered by divisibility) of the supports of the elements of  $\mathcal{F}$ . Since the supports of generalized power series are well ordered, the set  $\mathcal{G}$  of these minimal monomials is finite. We can now define the *blow-up height* of the family  $\mathcal{F}$ :

**Definition 2.2.** 1) Suppose given two monomials  $X^\alpha$  and  $X^\beta$ ,  $\alpha, \beta \in [0, \infty)^m$ . If  $\gcd(X^\alpha, X^\beta) = 1$ , we let

$$a = \#\{i \in \{1, \dots, m\} : \alpha_i \neq 0\} \text{ and } b = \#\{j \in \{1, \dots, m\} : \beta_j \neq 0\}$$

and we define the *blow-up height* of  $X^\alpha$  and  $X^\beta$  by:

$$b(X^\alpha, X^\beta) = \begin{cases} 0 & \text{if } X^\alpha = 1 \text{ or } X^\beta = 1 \\ a + b & \text{otherwise.} \end{cases}$$

In general, if  $\gcd(X^\alpha, X^\beta) = X^\omega$ , we set  $b(X^\alpha, X^\beta) = b(X^{\alpha-\omega}, X^{\beta-\omega})$ .

2) Given a finite family  $\mathcal{G}$  of monomials, the *blow-up height* of  $\mathcal{G}$  is the pair  $(p, q)$ , where  $p$  is the number of pairs of monomials in  $\mathcal{G}$  with nonzero blow-up heights and  $q$  is the minimum of the blow-up heights of such pairs if they exist, and  $(0, 0)$  otherwise.

3) The *blow-up height*  $b(\mathcal{F})$  of a finite family  $\mathcal{F} \subset A[[X^*]]$  is the blow-up height of its family of minimal monomials.

We can now define a transformation whose effect is to lower the blow-up height of a finite family of power series:

**Definition 2.3.** Assume  $m \geq 2$ . Given distinct  $i, j \in \{1, \dots, m\}$  and  $\gamma > 0$ , the *singular blow-up substitution* on  $X$  is the injective monoid homomorphism  $s_{ij}^\gamma: X^* \rightarrow X^*$  such that  $s_{ij}^\gamma(X_k) = X_k$  for  $k \neq i$  and  $s_{ij}^\gamma(X_i) = X_i X_j^\gamma$ . This morphism extends to an injective  $A$ -algebra endomorphism of  $A[[X^*]]$  by putting  $s_{ij}^\gamma(\sum c_\alpha X^\alpha) = \sum c_\alpha s_{ij}^\gamma(X^\alpha)$ .

**Proposition 2.4.** Consider a finite collection  $\mathcal{F}$  of formal generalized power series. Then:

- (1) If  $b(\mathcal{F}) \neq (0, 0)$  then there are  $\gamma > 0$  and distinct  $i, j \in \{1, \dots, m\}$  such that  $b(s_{ij}^\gamma(\mathcal{F})) < b(\mathcal{F})$  and  $b(s_{ji}^{1/\gamma}(\mathcal{F})) < b(\mathcal{F})$ .
- (2) If  $b(\mathcal{F}) = (0, 0)$ , then each nonzero  $f \in \mathcal{F}$  is of the form  $f = X^\omega g$  with  $g \in A[[X^*]]$ ,  $g(0) \neq 0$ .

As in classical analytic geometry, another transformation is needed to be able to give a geometric meaning to the notion of blow-up. Let

$$(X, Y) = (X_1, \dots, X_m, Y_1, \dots, Y_n)$$

be a tuple of  $m + n$  distinct indeterminates. We consider the subring  $A[[X^*, Y]]$  of  $A[[X, Y]^*]$  consisting of those  $f \in A[[X, Y]^*]$  in which the  $Y$ -indeterminates have only natural numbers as exponents. We have:



**Proposition 2.5.** *Let  $f \in A[[X^*, Y]]$  (with  $m \geq 2$ ), and let  $\gamma, \lambda > 0$ . Put  $X' = (X_1, \dots, X_{m-1})$ . Then the regular substitution  $r_{\gamma, \lambda}$  defined by*

$$r_{\gamma, \lambda}(f)(X', X_m, Y) = f(X', X_{m-1}^\gamma(\lambda + X_m), Y)$$

*maps  $A[[X^*, Y]]$  into  $A[[X'^*, X_m, Y]]$ .*

It is also proved in [DS98] that the algebras of *convergent* generalized power series are closed under the previous substitutions, regular and singular. Hence, the blowing-ups, adapted to the scale of monomials with real exponents, can be considered as geometric transformations. The effect of such transformations is to reduce the number of indeterminates with non integer exponents or to reduce the number of minimal monomials.

As we mentioned above, another classical (and crucial) tool is *Weierstrass' preparation*. Let us denote by  $A\{X^*, Y\}$  the sub-algebra of  $A[[X^*, Y]]$  which consists of *convergent* elements of  $A[[X^*, Y]]$ .

**Theorem 2.6.** *Consider a convergent generalized power series  $f \in \mathbb{R}\{X^*, Y\}$  regular of order  $d$  in the variable  $Y_n$ . Then  $f$  factors uniquely as  $f = UW$ , where  $U \in \{X^*, Y\}$  is a unit and  $W \in \mathbb{R}\{X^*, Y_1, \dots, Y_{n-1}\}[Y_n]$  is a monic polynomial of degree  $d$  in  $Y_n$ .*

Roughly speaking, these statements allow to transform, by finitely many blowing ups and linear transformations, a given generalized power series into a normal series or a polynomial in one of the indeterminates. The zero-set of such series is “simple”. More precisely, the quantifier free definable sets satisfy a general criterion for model-completeness, called the  $\Lambda$ -Gabriellov property, explained in the following section.

**2.2.  $\Lambda$ -Gabriellov property.** A set  $S \subset \mathbb{R}^k$  has *dimension* if  $S$  is a countable union of  $\mathcal{C}^1$ -manifolds. In that case we put

$$\dim(S) = \max \{ \dim(M) : M \subset S \text{ is a manifold} \}.$$

Consider a collection  $\Lambda_n$  of bounded subsets of  $\mathbb{R}^n$  be given for each  $n$ , and let  $\Lambda = (\Lambda_n)_{n \in \mathbb{N}}$ . An element  $A \in \Lambda$  is called a  $\Lambda$ -set, and a  $\Lambda$ -manifold if  $A$  is a manifold. A *sub- $\Lambda$ -set* is the image of a  $\Lambda$ -set under a linear projection. A sub- $\Lambda$ -set which is also a manifold is called a *sub- $\Lambda$ -manifold*.

**Definition 2.7.** A set  $A \subset \mathbb{R}^n$  has the  $\Lambda$ -Gabriellov property, if for each  $m \leq n$  there are *connected*  $\Lambda$ -manifolds  $B_1 \subset \mathbb{R}^{n+q_1}, \dots, B_k \subset \mathbb{R}^{n+q_k}$ , where  $q_1, \dots, q_k \in \mathbb{N}$ , such that

$$\Pi_m(A) = \Pi_m(B_1) \cup \dots \cup \Pi_m(B_k)$$

where  $\Pi_m$  means the linear projection onto  $\mathbb{R}^m$ , and, for each  $i = 1, \dots, k$  we have:

- (1)  $\text{fr}(B_i) = \overline{B_i} \setminus B_i$  is included in a closed sub- $\Lambda$ -set  $D_i \subset \mathbb{R}^{n+q_i}$  such that  $D_i$  has dimension with  $\dim(D_i) < \dim(B_i)$ ;
- (2)  $\dim(B_i) \leq m$ , and there is a strictly increasing sequence  $\lambda \in \{1, \dots, m\}^d$ , with  $d = \dim(B_i)$ , such that  $\Pi_\lambda|_{B_i} : B_i \rightarrow \mathbb{R}^d$  is an immersion.

From now on, we assume moreover that  $\Lambda = (\Lambda_n)_{n \in \mathbb{N}}$  where each  $\Lambda_n$  is a collection of subsets of  $[-1, 1]^n$  which contains the diagonals and the complement of the diagonals, which is closed under union and intersection, and such that, for every  $A \in \Lambda_n$ , we have:

- (1)  $[-1, 1] \times A$  and  $A \times [-1, 1]$  belongs to  $\Lambda_{n+1}$ .

(2)  $A$  has the  $\Lambda$ -Gabriellov property.

The next result [DS98, Theorem 2.7] is the fundamental property which leads in several situations, modulo routine arguments, to model completeness and o-minimality:

**Theorem 2.8.** *If  $E \subset [-1, 1]^m$  is a sub- $\Lambda$ -set, then  $[-1, 1]^m \setminus E$  is a sub- $\Lambda$ -set.*

Actually, it is not that easy to prove that the  $\Lambda$ -Gabriellov property is a consequence of the blow-up process described in the previous section and from Weierstrass' preparation. But this goal can be achieved via classical methods, namely a *fiber cutting lemma* [DS98, 8.12], directly inspired by its analytic analogue [BM88, Lemma 3.6].

We have given quite a lot of details in this section, because we consider that the results of the paper [DS98] are of great importance. In some sense, all the subsequent proofs of o-minimality via model completeness consist in convenient adaptations of the methods explained here : blow-up substitutions, Weierstrass preparation, fiber cutting lemma, and  $\Lambda$ -Gabriellov property. Hence in the next sections, we simply give the main result of the corresponding papers, and add short comments.

### 3. QUASIANALYTICITY AND O-MINIMALITY

Let us recall the question asked by L. van den Dries in his survey [Dri99]: *does quasianalyticity imply o-minimality?* A precise answer to this question is given in [RSW03] by the author of this survey, P. Speissegger and A. Wilkie. Actually it is proved there that a family of quasianalytic algebras closed under reasonable operations generates a polynomially bounded o-minimal expansion of the real field. Let us state this result more precisely.

Consider, for each compact box  $B = [a_1, b_1] \times \cdots \times [a_n, b_n] \subset \mathbb{R}^n$ ,  $n \in \mathbb{N}$ , an  $\mathbb{R}$ -algebra  $\mathcal{C}_B$  of functions  $f: B \rightarrow \mathbb{R}$  such that:

- C1:**  $\mathcal{C}_B$  contains the functions  $(x_1, \dots, x_n) \mapsto x_i$ , and for every  $f \in \mathcal{C}_B$ , the restriction of  $f$  to  $\text{int}(B)$  is  $C^\infty$ ;
- C2:** if  $B' \subset \mathbb{R}^m$  is a compact box and  $g_1, \dots, g_n \in \mathcal{C}_{B'}$  are such that  $g(B') \subset B$ , where  $g = (g_1, \dots, g_n)$ , then for every  $f \in \mathcal{C}_B$  the function  $y \mapsto f(g_1(y), \dots, g_n(y))$  belongs to  $\mathcal{C}_{B'}$ ;
- C3:** for every compact box  $B' \subset B$  we have  $f|_{B'} \in \mathcal{C}_{B'}$  for all  $f \in \mathcal{C}_B$ , and, for every  $f \in \mathcal{C}_B$  there is a compact box  $B' \subset \mathbb{R}^n$  and  $g \in \mathcal{C}_{B'}$  such that  $B \subset \text{int}(B')$  and  $g|_B = f$ ;
- C4:**  $\partial f / \partial x_i \in \mathcal{C}_B$  for every  $f \in \mathcal{C}_B$  and each  $i = 1, \dots, n$ .

For every polyradius  $r = (r_1, \dots, r_n) \in (0, \infty)^n$ , we put

$$I_r = (-r_1, r_1) \times \cdots \times (-r_n, r_n) \text{ and } \bar{I}_r = \text{cl}(I_r)$$

If  $\varepsilon > 0$ , we write  $I_\varepsilon = (-\varepsilon, \varepsilon)^n$ . We denote by  $\mathcal{C}_n$  the collection of all germs at the origin of the functions in  $\bigcup_{r \in (0, \infty)^n} \mathcal{C}_{\bar{I}_r}$ . Let  $\hat{\cdot}: \mathcal{C}_n \rightarrow \mathbb{R}[[X]] = \mathbb{R}[[X_1, \dots, X_n]]$  be the map that sends each germ to its (infinite) Taylor series at the origin.

We add the following assumptions:

- C5:** The map  $\hat{\cdot}$  defined on  $\mathcal{C}_n$  is injective (*quasianalyticity*);
- C6:** if  $n > 1$  and  $f \in \mathcal{C}_n$  is such that  $f(0) = 0$  and  $(\partial f / \partial x_n)(0) \neq 0$ , there is an  $\alpha \in \mathcal{C}_{n-1}$  with  $\alpha(0) = 0$  and  $f(x', \alpha(x')) = 0$  (where  $x' = (x_1, \dots, x_{n-1})$ ) (*implicit function*);

**C7:** if  $f \in \mathcal{C}_n$  and  $i \leq n$  are such that  $\hat{f}(X) = X_i G(X)$  for some  $G(X) \in \mathbb{R}[[X]]$ , then  $f = x_i g(x)$  for some  $g \in \mathcal{C}_n$  such that  $G = \hat{g}$ .

We then have the following result:

**Theorem 3.1.** *Consider a collection of algebras  $\mathcal{C}_B$  satisfying the conditions **C1-C7**. For each  $n \in \mathbb{N}$ , we put  $K_n = [-1, 1]^n$ . For each function  $f \in \mathcal{C}_{K_n}$  we define the function  $\tilde{f}: \mathbb{R}^n \rightarrow \mathbb{R}$  by  $\tilde{f}(x) = f(x)$  if  $x \in K_n$  and  $\tilde{f}(x) = 0$  otherwise. Then the expansion of the real ordered field by the functions  $\tilde{f}$  is o-minimal, model complete and polynomially bounded.*

*Remark 3.2.* It is worth noticing that the closure properties required in this theorem are not so far from what is suggested in the very initial strategy conceived by L. van den Dries in [Dri84].

The proof of this result is mostly based on the techniques described in Section 2. We should however notice the lack of Weierstrass' preparation in the general quasianalytic framework. It implies that the hypothesis of the  $\Lambda$ -Gabrielov property for quantifier free definable sets has to be obtained by slightly different methods, involving a more accurate blowing-up process, leading to a normalization of every quasianalytic germ of our initial system.

Let us mention the two main applications of the above theorem given in [RSW03]. They are both based on a well known special case of quasianalytic system satisfying the hypothesis C1 to C7, namely the *quasianalytic Denjoy-Carleman classes*. Let us recall one nice result, due initially to S. Mandelbrojt, which has some non-obvious consequences in o-minimality:

**Theorem 3.3.** *Given any  $C^\infty$  function  $f: [-1, 1] \rightarrow \mathbb{R}$ , there exist two  $C^\infty$  functions  $f_1, f_2: [-1, 1] \rightarrow \mathbb{R}$  belonging to different quasianalytic Denjoy-Carleman classes, such that:*

- (1)  $f = f_1 + f_2$ .
- (2)  $f_1$  (resp.  $f_2$ ) is definable in an o-minimal expansion  $\mathcal{R}_1$  (resp.  $\mathcal{R}_2$ ) of the ordered real field.

We immediately deduce from this result the negative answers (as it was expected) to two questions quoted from [Dri99]:

- 1. If  $f$  is an *oscillating* function, the structures  $\mathcal{R}_1$  and  $\mathcal{R}_2$  are "incompatible": they do not admit a common o-minimal expansion. Hence there is no largest o-minimal expansion of the real field.
- 2. If  $f$  is a  $C^\infty$  function which is not analytic at any point of the interval  $[-1, 1]$ , then there exists an interval on which either  $f_1$  or  $f_2$  is nowhere analytic. Hence at least one of the two structures  $\mathcal{R}_1$  and  $\mathcal{R}_2$  does not admit smooth cell decomposition.

#### 4. NON-OSCILLATING TRAJECTORIES OF ANALYTIC VECTOR FIELDS

In [RSS07], the author of this survey, F. Sanz, R. Schäfke apply the above general quasianalytic result to some non-oscillating trajectories of real analytic vector fields. The difficult part here is to prove that the algebras generated by the components of the trajectories via operations, like monomial division and taking implicit function, are quasianalytic. This is a consequence of some assumptions on the so-called "Stokes phenomenon" of the formal asymptotic expansion of these components. The initial goals of this work were:

- (1) to prove model completeness for the structure generated by some pfaffian curves (such as the solutions of Euler’s differential equation  $x^2y' - y = x$ ); recall that model completeness is not a consequence of A. Wilkie’s general pfaffian result [Wil99];
- (2) extending o-minimality to non pfaffian (that is, non definable in the Pfaffian closure of  $\mathbb{R}_{\text{an}}$ ) non oscillating trajectories of vector fields.

These goals are achieved, but two surprising unexpected results appear as consequences of the main theorem of this paper:

- (1) There exists, not only pairs of, as was proved in [RSW03], but an infinite family of pairwise “incompatible” o-minimal expansions of the reals. Moreover, the elements of this family are generated by trajectories of the same polynomial vector field.
- (2) There exists a non oscillating trajectory of a polynomial vector field which is not o-minimal. However, the existence of such a trajectory for an analytic vector field in dimension 3 is still an important open question.

5. AN O-MINIMAL STRUCTURE WITHOUT  $\mathcal{C}^\infty$  CELL DECOMPOSITION AND GENERICITY

O. Le Gal and the author of this survey give in [LR09] an (expected) negative answer to another question of [Dri99]: *does every o-minimal expansion of the real field admit smooth cell decomposition?*

The idea of the construction is to “create” quasianalyticity with a function  $H: \mathbb{R} \rightarrow \mathbb{R}$ , whose germ at the origin is weakly  $\mathcal{C}^\infty$  but not  $\mathcal{C}^\infty$ . More precisely, inspired by similar results for Hardy fields, the authors consider a formal power series  $\hat{h}(x) = \sum a_n x^n$  whose coefficients are all algebraically independent over the field of the rationals. Then, by a slight modification of Borel’s method, they build a function  $H: \mathbb{R} \rightarrow \mathbb{R}$  such that:

- (1)  $H$  is weakly  $\mathcal{C}^\infty$  but not  $\mathcal{C}^\infty$  at the origin.
- (2) The Taylor expansion of  $H$  at the origin is  $\hat{h}(x)$ .
- (3) The restriction of  $H$  to the complement of any open interval centered at  $0 \in \mathbb{R}$  is piecewise polynomial (with finitely many pieces).

The work consists then in proving that the hypotheses on  $\hat{h}(x)$  imply the quasianalyticity of the algebras of germs generated by  $H$  via the usual operations (composition, implicit function, etc.). Moreover, one has to check that the general quasianalyticity result of [RSW03] can be adapted to this non- $\mathcal{C}^\infty$  framework.

O. Le Gal uses in [Gal10] these methods based on a transcendence property of the coefficients of the Taylor expansion to obtain two nice results:

- (1) The set of elements of  $\mathcal{C}^\infty([0, 1], \mathbb{R})$  which generate an o-minimal expansion of the reals is residual for some Whitney topology.
- (2) There exists an o-minimal expansion  $\mathbb{R}_h$  of the real field by a function  $h \in \mathcal{C}^\infty([0, 1], \mathbb{R})$  such that  $\mathbb{R}_{\text{an},h}$  is not o-minimal.

6. PARTIAL O-MINIMAL ANSWERS TO DULAC’S PROBLEM

The analysable functions introduced by Ecalle in [Éca92] are considered since the beginning as a possible target for o-minimal methods. They appear in Dulac’s problem: consider an analytic planar vector field  $X$ , and a non-degenerate

monodromic polycycle  $\Gamma$  of  $X$  (non degenerate meaning that the vector has a non-nilpotent linear part at each vertex of  $\Gamma$ ). The problem is to prove that the first return map  $P$  of  $\Gamma$  cannot have an accumulating sequence of isolated fixed points.

The classical treatment of this problem consists in writing  $P$  as a finite composition of restricted analytic and non-analytic transition maps defined in the neighborhood of each singular point. Proving the o-minimality of  $P$  would be a remarkable result, of great help in the proof of the celebrated Hilbert 16-th problem: *prove that a planar polynomial vector field admits at most finitely many limit cycles*. The development of o-minimal techniques suitable to Dulac’s problem is a major research topic at this time. So far, only one result in this direction has been published in [KRS09]:

**Theorem 6.1.** *If all the vertices of the polycycle  $\Gamma$  are hyperbolic and non resonant (which means that the linear part of the vector field  $X$  admits, for each of these vertices, two eigenvalues of opposite sign, with an irrational ratio), then the Poincaré first return map of  $\Gamma$  is defined in an o-minimal, model complete and polynomially bounded expansion of the real field.*

It is known, after Dulac, that the transition maps of each vertex has an asymptotic expansion  $\sum c_n x^{\alpha_n}$  where  $(\alpha_n)$  is an increasing and unbounded sequence of positive real numbers. Ilyashenko proves in [Il’91] the quasianalyticity of this asymptotic expansion. In this situation the theorem is obtained by applying all the methods explained in this survey.

The general case (which would involve non hyperbolic, or hyperbolic resonant vertices) leads to non polynomially bounded (yet exponentially bounded) asymptotic expansions. The quasianalyticity is clear for hyperbolic vertices, and much more involved for non hyperbolic vertices. But, even in the hyperbolic case, working with divergent series, in several variables, involving log-exp monomials, seems extremely difficult.

7. TWO NON POLYNOMIALLY BOUNDED EXAMPLES

**7.1. The pfaffian structures.** Since the original work of A. Khovanskii [Kho91], one can find in the literature several definitions of Pfaffian sets and Pfaffian functions. One of them, based on the notion of *Rolle leaves* of foliations of codimension 1, has been introduced by R. Moussu and C.A. Roche in [MR91]. Wilkie works with another definition, closer to Khovanskii’s original one:

**Definition 7.1.** A  $C^1$  function  $f: \mathbb{R}^n \rightarrow \mathbb{R}$  is called *Pfaffian* if there exist  $C^1$  functions  $f_1, \dots, f_k: \mathbb{R}^n \rightarrow \mathbb{R}$  with  $f_k = f$ , such that for each  $i, j$  with  $1 \leq i \leq k$  and  $1 \leq j \leq n$ ,  $\partial f_i / \partial x_j$  is expressible as a polynomial in  $x_1, \dots, x_n, f_1, \dots, f_i$ . The expansion of the real field by all pfaffian functions is denoted by  $\mathbb{R}_{\text{Pfaff}}$ .

The main result of [Wil99] is:

**Theorem 7.2.** *The structure  $\mathbb{R}_{\text{Pfaff}}$  is o-minimal.*

This result is a consequence of a general method leading to o-minimality. Suppose  $n \geq 1$  and  $A \subset \mathbb{R}^n$ . Let  $\gamma(A)$  denote the smallest natural number  $N$  with the following property: for every affine subspace  $X$  of  $\mathbb{R}^n$  we have  $A \cap X = A_1 \cup \dots \cup A_N$  for some connected subsets  $A_1, \dots, A_N$  of  $\mathbb{R}^n$ . If no such  $N$  exists we write  $\gamma(A) = \infty$ .

**Theorem 7.3.** *Let  $\mathcal{M}$  be an expansion of the ordered field of real numbers by  $C^\infty$  functions. Suppose that for each  $n \geq 1$  every quantifier-free,  $\mathcal{M}$ -definable (with parameters) subset  $A$  of  $\mathbb{R}^n$  satisfies  $\gamma(A) < \infty$ . Then  $\mathcal{M}$  is o-minimal.*

The method of proof has, at least apparently, nothing to do with any blow-up method. It is instead based on a way to approach the boundary of definable sets which allows to control their topology.

This result looks very impressive. Instead of proving the finiteness property for every definable set (or every definable subset of the real line), it is enough to focus on the *quantifier free* definable sets, for which a uniform finiteness property is required<sup>6</sup>. Actually, Wilkie uses the uniform finiteness for pfaffian sets proved in Khovanskii’s work to deduce the o-minimality of  $\mathbb{R}_{\text{Pfaff}}$ . However, it turns out that, given a collection of  $C^\infty$  functions, it is not that easy to prove the finiteness property for quantifier free definable sets. To our knowledge, the structure  $\mathbb{R}_{\text{Pfaff}}$  (or its variants) is the only one which has been proved to be o-minimal by this method. For example, several attempts have been made to use Wilkie’s theorem to prove o-minimality for non oscillating trajectories of analytic vector fields in dimension 3. So far, they are unsuccessful.

**7.2. Quantifier elimination for exponential structures.** L. van den Dries, A. Macintyre and D. Marker prove in [DMM94] the following result:

**Theorem 7.4.** *The theory  $T_{\text{an}}(\text{exp})$  admits quantifier elimination in the language  $T_{\text{an}}(\text{exp}, \log)$ .*

This result is proved via a study of the valuation properties of (non standard) models of  $T_{\text{an}}(\text{exp})$ : given two models  $F \subset K$  of this theory and a element  $y$  of  $K \setminus F$ , how does the valuation group of the Skolem closure  $F \langle y \rangle$  in  $K$  behave, compared to the valuation group of  $F$ ? This approach is closer to a blowing-up approach than it looks. Translated in a more conventional language of equations and solutions, it may be understood as a way of dealing with equations as  $f(\bar{x}, y) = 0$ , where  $\bar{x} = (x_1, \dots, x_n)$  and  $f$  is an  $\text{exp} - \log$  analytic function. More precisely, the idea is to detect the possible “principal parts” of the solutions (valuative analysis), and then to deduce from this initial part a change of variables which transforms  $f$  into a *simpler* equation (blow-up). Of course we have in mind a notion of blowing-up adapted to the  $\text{exp} - \log$  scale. This approach, which is literally a geometric translation of the model theoretic methods of [DMM94], has been done by J.-M. Lion and the author of this survey, leading to their “preparation theorem for  $\text{exp} - \log$  functions” in [LR97].

**Example.** In order to give a simple example of these ideas, we consider the equation  $y \log y = x$ . Let us describe the process with allows to solve it wrto  $y$  in a neighborhood of  $+\infty$ . We consider  $y \log y$  and  $x$  as two “monomials”, namely two “vertices” of the “Newton polygon” of the equation. As in the classical process, we have to compute the “slope” of the line which joins these two vertices. In order to determine this “slope”, we apply the logarithm function to the two members of the equation :

$$\log y + \log(\log y) = \log x.$$

<sup>6</sup>Actually, J.-M. Lion proved in [Lio02] that the word “uniform” can be removed if the structure  $\mathcal{M}$  is generated by algebras of  $C^\infty$  functions closed under partial derivatives.

Hence  $\log y \sim \log x$  and  $y \sim \frac{x}{\log x}$ . This monomial is the “slope” we were looking for. Now, still following the classical process, we can introduce the following change of variables :

$$y = \frac{x}{\log x} (1 + y_1), \text{ and } \log y = \log \left( \frac{x}{\log x} \right) + \log (1 + y_1)$$

which is *analytic* wrto the variable  $y_1$  (because  $y_1 \sim 0$ ). Hence, this change of variables, which is nothing but a blowing-up transformation in the logarithmic-exponential scale, transforms the original equation (which is “transcendental” in the variable  $y$ ), into a new equation (which is analytic in the variable  $y_1$ ).

It would be interesting (for example in vue of Dulac’s problem) to know if such methods, model-theoretic or geometric, could be extended to algebras of functions which would admit divergent  $\exp - \log$  series as asymptotic expansions (whatever it means!).

8. O-MINIMALITY AND NUMBER THEORY

This is a more recent and very promising direction for research in o-minimality. We mention only one result in this survey, but, undoubtedly, this topic will deserve its own survey very soon. J. Pila and A. Wilkie prove in [PW06] address the problem of the distribution of rational and integer points on certain nonalgebraic sets in  $\mathbb{R}^n$ . More precisely, they give a nice estimation of the number of rational points with a controlled *height* belonging to a definable set.

The height is defined in the following way. If  $a/b \in \mathbb{Q}$ , with  $b > 0$  and  $\gcd(a, b) = 1$ , then its height is defined by  $H(a/b) = \max(|a|, b)$ . The height of a tuple of rational numbers is defined by  $H(\alpha_1, \dots, \alpha_n) = \max(H(\alpha_j))$ . If  $X \subset \mathbb{R}^n$ , let  $X(\mathbb{Q})$  denote the subset of points with rational coordinates. For  $T > 1$  we set:

$$X(\mathbb{Q}, T) = \{P \in X(\mathbb{Q}) : H(P) \leq T\}$$

and define the *density function* of  $X$  to be

$$N(X, T) = \#X(\mathbb{Q}, T)$$

We have:

**Theorem 8.1.** *Consider an o-minimal expansion  $\mathcal{S}$  of the real field, a definable set  $X \subset \mathbb{R}^n$ , and let  $\varepsilon > 0$ . Denote by  $X^{\text{alg}}$  the union of all connected semialgebraic subsets of  $X$  of positive dimension, Then there is a constant  $c(X, \varepsilon)$  such that*

$$N(X - X^{\text{alg}}, T) \leq c(X, \varepsilon) T^\varepsilon$$

The exclusion of the algebraic part  $X^{\text{alg}}$  is similar to the “exclusion of the special set” in diophantine geometry, for example in the formulation of the conjecture of Lang, which asserts that an algebraic variety has finitely many rational points outside its “special set”. The diophantine part of the proof of the above theorem follows the strategy going back to former works of J. Pila. The heart of the analytic part of the proof is the possibility of a certain uniform parameterization of the fibers in a definable family. This is achieved by establishing an o-minimal version of Gromov’s algebraic reparameterization lemma, which obtains such parameterizations for closed semi-algebraic sets.

## 9. CONCLUSION

Among the questions asked in [Dri84], at least two of them seem to need ideas still missing.

1. *The possible o-minimality of Ecalle's analysable functions.* Any technique would be welcome, including a deep understanding of resurgent functions, Stokes phenomena, real summation process, ... It should be a long, hard and fascinating work!

2. *The existence of a transexponential o-minimal expansion of the real field.* Of course, a natural possible starting point seems to be the existence of transexponential Hardy fields. But what else should be involved? To make a comparison, the existence of Hardy fields with non  $C^\infty$  elements was known for a long time. But it was not sufficient to prove the existence of o-minimal structures without  $C^\infty$  cell decomposition, before the o-minimalist community acquired some familiarity with quasianalyticity. Is it reasonable to expect an extension of this notion to a transexponential setting?

## REFERENCES

- [BL71] J. T. Baldwin and A. H. Lachlan, *On strongly minimal sets*, J. Symbolic Logic **36** (1971), 79–96.
- [BM88] E. Bierstone and P. D. Milman, *Semianalytic and subanalytic sets*, Inst. Hautes Études Sci. Publ. Math. (1988), no. 67, 5–42.
- [Col75] G. E. Collins, *Quantifier elimination for real closed fields by cylindrical algebraic decomposition*, Automata theory and formal languages, 1975.
- [Cos00] M. Coste, *An introduction to o-minimal geometry*, Dip. Mat. Univ. Pisa, Dottorato di Ricerca in Matematica, 2000, Dipartimento di Matematica Dell'Università di Pisa.
- [DD88] J. Denef and L. van den Dries, *p-adic and real subanalytic sets*, Ann. of Math. (2) **128** (1988), no. 1, 79–138.
- [DM94] L. van den Dries and C. Miller, *On the real exponential field with restricted analytic functions*, Israel J. Math. **85** (1994), no. 1-3, 19–56.
- [DM96] ———, *Geometric categories and o-minimal structures*, Duke Math. J. **84** (1996), no. 2, 497–540.
- [DMM94] L. van den Dries, A. Macintyre, and D. Marker, *The elementary theory of restricted analytic fields with exponentiation*, Ann. of Math. (2) **140** (1994), no. 1, 183–205.
- [Dri84] L. van den Dries, *Remarks on Tarski's problem concerning  $(\mathbf{R}, +, \cdot, \exp)$* , Logic colloquium '82 (Florence, 1982), North-Holland, Amsterdam, 1984, pp. 97–121.
- [Dri98] ———, *Tame topology and o-minimal structures*, Cambridge University Press, Cambridge, 1998.
- [Dri99] ———, *o-minimal structures and real analytic geometry*, Current developments in mathematics, 1998 (Cambridge, MA), Int. Press, Somerville, MA, 1999, pp. 105–152.
- [DS98] L. van den Dries and P. Speissegger, *The real field with convergent generalized power series*, Trans. Amer. Math. Soc. **350** (1998), no. 11, 4377–4421.
- [DS00] ———, *The field of reals with multisummable series and the exponential function*, Proc. London Math. Soc. (3) **81** (2000), no. 3, 513–565.
- [Éca92] Jean Écalle, *Introduction aux fonctions analysables et preuve constructive de la conjecture de Dulac*, Actualités Mathématiques. [Current Mathematical Topics], Hermann, Paris, 1992.
- [Gab68] A. M. Gabrielov, *Projections of semianalytic sets*, Funkcional. Anal. i Priložen. **2** (1968), no. 4, 18–30.
- [Gal10] O. Le Gal, *A generic condition implying o-minimality for restricted  $C^\infty$  functions*, Annales de la Faculté des Sciences de Toulouse **XIX** (2010), no. 3-4, 479–492.
- [Gro97] A. Grothendieck, *Esquisse d'un programme*, Geometric Galois actions, 1, London Math. Soc. Lecture Note Ser., vol. 242, Cambridge Univ. Press, Cambridge, 1997, With an English translation on pp. 243–283, pp. 5–48.



- [Hir73] H. Hironaka, *Introduction to real-analytic sets and real-analytic maps*, Istituto Matematico “L. Tonelli” dell’Università di Pisa, Pisa, 1973, Quaderni dei Gruppi di Ricerca Matematica del Consiglio Nazionale delle Ricerche.
- [Il’91] Yu. S. Il’yashenko, *Finiteness theorems for limit cycles*, Translations of Mathematical Monographs, vol. 94, American Mathematical Society, Providence, RI, 1991.
- [Kho91] A. G. Khovanskii, *Fewnomials*, American Mathematical Society, Providence, RI, 1991, Translated from the Russian by Smilka Zdravkovska.
- [KPS86] Julia F. Knight, Anand Pillay, and Charles Steinhorn, *Definable sets in ordered structures. II*, Trans. Amer. Math. Soc. **295** (1986), no. 2, 593–605.
- [KRS09] T. Kaiser, J.-P. Rolin, and P. Speissegger, *Transition maps at non-resonant hyperbolic singularities are o-minimal*, J. Reine Angew. Math. **636** (2009), 1–45.
- [Lio02] J.-M. Lion, *Finitude simple et structures o-minimales*, J. Symbolic Logic **67** (2002), no. 4, 1616–1622.
- [Łoj71] S. Łojasiewicz, *Sur les ensembles semi-analytiques*, Actes du Congrès International des Mathématiciens (Nice, 1970), Tome 2, Gauthier-Villars, Paris, 1971, pp. 237–241.
- [LR97] J.-M. Lion and J.-P. Rolin, *Théorème de préparation pour les fonctions logarithmico-exponentielles*, Ann. Inst. Fourier (Grenoble) **47** (1997), no. 3, 859–884.
- [LR09] O. Le Gal and J.-P. Rolin, *An o-minimal structure which does not admit  $C^\infty$  cellular decomposition*, Ann. Inst. Fourier **59**, (2009), no. 2, 543–562.
- [MR91] R. Moussu and C. Roche, *Théorie de Hovanskiĭ et problème de Dulac*, Invent. Math. **105** (1991), no. 2, 431–441.
- [Osg16] William F. Osgood, *On functions of several complex variables*, Trans. Amer. Math. Soc. **17** (1916), no. 1, 1–8.
- [PS84] A. Pillay and C. Steinhorn, *Definable sets in ordered structures*, Bull. Amer. Math. Soc. (N.S.) **11** (1984), no. 1, 159–162.
- [PS86] ———, *Definable sets in ordered structures. I*, Trans. Amer. Math. Soc. **295** (1986), no. 2, 565–592.
- [PS88] Anand Pillay and Charles Steinhorn, *Definable sets in ordered structures. III*, Trans. Amer. Math. Soc. **309** (1988), no. 2, 469–476.
- [PW06] J. Pila and A. J. Wilkie, *The rational points of a definable set*, Duke Math. J. **133** (2006), no. 3, 591–616.
- [RSS07] J.-P. Rolin, F. Sanz, and R. Schäfke, *Quasi-analytic solutions of analytic ordinary differential equations and o-minimal structures*, Proc. London Math. Soc. **95** (2007), no. 2, 413–442.
- [RSW03] J.-P. Rolin, P. Speissegger, and A. J. Wilkie, *Quasianalytic Denjoy-Carleman classes and o-minimality*, J. Amer. Math. Soc. **16** (2003), no. 4, 751–777.
- [Shi97] M. Shiota, *Geometry of subanalytic and semialgebraic sets*, Progress in Mathematics, vol. 150, Birkhäuser Boston Inc., Boston, MA, 1997.
- [Tar51] A. Tarski, *A decision method for elementary algebra and geometry*, University of California Press, Berkeley and Los Angeles, Calif., 1951, 2nd ed.
- [Wil96] A. J. Wilkie, *Model completeness results for expansions of the ordered field of real numbers by restricted Pfaffian functions and the exponential function*, J. Amer. Math. Soc. **9** (1996), no. 4, 1051–1094.
- [Wil99] ———, *A theorem of the complement and some new o-minimal structures*, Selecta Math. (N.S.) **5** (1999), no. 4, 397–421.

*Current address:* IMB, Université de Bourgogne, Dijon, France

*E-mail address:* rolin@u-bourgogne.fr



**ABSTRACTS**



ABSTRACTS

---

**Francesca Acquistapace**, *On Pfister's multiplicative formulae for the ring of real analytic functions :*

We present “infinite” multiplicative formulae for countable collections of sums of squares (of meromorphic functions on  $\mathbb{R}^n$ ). Our formulae generalize the classical Pfister’s ones concerning the representation as a sum of  $2^r$  squares of the product of two elements of a field  $K$  which are sums of  $2^r$  squares. As a main application, we reduce the representation of a positive semidefinite analytic function on  $\mathbb{R}^n$  as a sum of squares to the representation as sums of squares of its irreducible factors.

Joint work with Fabrizio Broglia and José F. Fernando.

---

**Janusz Adamus**, *Tameness of complex dimensions in real algebraic sets :*

Given a real-algebraic (or more generally, semialgebraic) set  $R$  in a complex ambient space, a natural question to ask is how much of the complex structure is inherited (locally) by  $R$ . One way of measuring this influence at a point  $p \in R$  is to look at the minimal dimension of a complex germ containing  $R_p$  and, dually, the maximal dimension of a complex germ contained in  $R_p$ . We will consider the problem of tameness of these “outer” and “inner” complex dimensions along  $R$ .

Joint work with Serge Randriambololona and Rasul Shafikov.

---

**Alexandre Bardet**, *Diviseurs à support réel sur les courbes réelles :*

Dans un article sur les sommes de carrés, Scheiderer a montré que pour toute courbe réelle projective lisse, il existe un entier naturel  $N$  tel que tout diviseur de degré plus grand que  $N$  soit linéairement équivalent à un diviseur dont le support est totalement réel. Bien que la preuve laisse penser que l’entier  $N$  est grand, Huissman et Monnier ont montré qu’on pouvait prendre  $N = g - 1 + s$  si le nombre de composantes connexes  $s$  est plus grand que  $g$ . On s’intéressera alors à étendre des résultats de Monnier sur un analogue concernant les courbes singulières.

---

**Salvatore Barone**, *Refined bounds on the number of connected components of sign conditions on a variety :*

Let  $\mathbb{R}$  be a real closed field,  $\mathcal{P}, \mathcal{Q} \subset \mathbb{R}[X_1, \dots, X_k]$  finite subsets of polynomials, with the degrees of the polynomials in  $\mathcal{P}$  (resp.  $\mathcal{Q}$ ) bounded by  $d$  (resp.  $d_0$ ). Let  $V \subset \mathbb{R}^k$  be the real algebraic variety defined by the polynomials in  $\mathcal{Q}$  and suppose that the real dimension of  $V$  is bounded by  $k'$ . We prove that the number of semi-algebraically connected components of the realizations of all realizable sign conditions of the family  $\mathcal{P}$  on  $V$  is bounded by

$$2^{k-k'} (2^k + 1) d_0^{k-k'} \sum_{j=0}^{k'} 4^j \binom{s+1}{j} d^j \max\{2d_0, d\}^{k'-j}.$$

In case  $2d_0 \leq d$ , the above bound can be written simply as

$$\left(\sum_{j=0}^{k'} \binom{s+1}{j}\right) d^{k'} d_0^{k-k'} O(1)^k = (sd)^{k'} d_0^{k-k'} O(1)^k.$$

This improves in certain cases (when  $d_0 \ll d$ ) the best known bound of

$$\sum_{1 \leq j \leq k'} \binom{s}{j} 4^j d(2d-1)^{k-1}$$

on the same number proved in the case  $d = d_0$ . The distinction between the bound  $d_0$  on the degrees of the polynomials defining the variety  $V$  and the bound  $d$  on the degrees of the polynomials in  $\mathcal{P}$  that appears in the new bound seems to be significant in several applications in discrete geometry, especially in recent work on bounding incidences between points and algebraic varieties in fixed dimensional real affine spaces.

**Frédéric Bihan**, *Recent Fewnomial Bounds* :

Since the work of A. Khovanskii on Fewnomials, we know explicit bounds on the topology of real algebraic varieties, in particular on the number of real solutions to polynomial systems, which depend only on the number of monomials appearing in the defining equations. Such bounds are better than the classical ones when the number of monomials is small comparatively to the degrees. This talk will survey recent fewnomial bounds, including bounds which take into account additional structures on the supports of the equations.

**Ludwig Broecker**, *Stability indices over  $\mathbb{R}((X))$  and  $p$ -adic fields* :

Basic sets are the generators for the lattice of all semialgebraic sets over  $R((X))$  or  $p$ -adic fields. For the semialgebraic sets one has elimination of quantifiers. However, the basic sets are defined by  $n$ -th power predicates for arbitrary  $n$ . (Over the ordinary reals  $n = 2$  is sufficient). As for the reals we present bounds, only depending on the dimension of the ambient space, for the number of polynomials which is required to describe arbitrary basic sets.

**Sabine Burgdorf**, *Hilbert's question on trace-positive polynomials* :

Hilbert proved that a ternary quartic is nonnegative if and only if it can be written as a sum of squares of polynomials whereas this is false in general if the degree of the polynomial exceeds four. We will consider the question if the same holds true in the tracial context. Namely, a real polynomial in non-commuting variables is called trace-positive if its trace is nonnegative under all matrix evaluations of symmetric matrices or of a given semialgebraic set  $K$  of symmetric matrices. These polynomials are intimately connected to the embedding conjecture of Connes, which corresponds to Tsirelson's problem from Quantum Physics. A second connection to Quantum Physics is given via the BMV conjecture. We present results and examples concerning the question whether a trace-positive polynomial can be written as a sum of hermitian squares and commutators. If time permits we will also focus on the dual problem given by the tracial  $K$ -moment problem.

Joint work with Igor Klep.

---

**Fabrizio Catanese**, *Moduli spaces of Galois coverings of algebraic curves.*

---

**Yann Cogan**, *Minimal degree of affine algebraic surfaces of given genus :*

We present a study of the minimal degree of all smooth compact connected algebraic surfaces of  $\mathbb{R}^3$  of given genus. We prove that this minimal degree is equal to

- (i) 4 in genus 1, 2, 3, 4, 5,
- (ii) 6 in genus 10, 11,  $\dots$ , 27, 28,
- (iii) 8 in genus 63, 64,  $\dots$ , 80, 81, and
- (iv) 10 in genus 172, 173, 174, 175, 176.

The result is based on level surfaces of sums of Tchebychev's polynomials of even degree  $d$  (Banchov-Chmutov surfaces). It's genus is  $(\frac{d}{2} - 1)^2(d + 1)$ . For example, the Banchov-Chmutov surface of degree 4 has genus equal to 5, and the one of degree 6 has genus equal to 28.

An explicit perturbation of the polynomial allows us to reduce the genus of the surface without losing connectedness, compactness and smoothness. For each even degree  $d$ , any genus less than  $(\frac{d}{2} - 1)^2(d + 1)$  can be obtained in this way. It results in an upper bound of the minimal degree in terms of the genus.

The Inequality of Milnor-Olienik-Petrovski-Thom, and Kharlamov's Theorem on projective quartic surfaces give rise to a lower bound of the minimal degree of a surface of genus  $g$ . Finally, we obtain the exact values given above, and tight bounds in other cases. The question of the minimal degree of surfaces of genus 6, 7, 8 and 9, in particular, remains open. It is equal to 4 or 6.

---

**Marc Coppens**, *Separating pencils on  $(M - 2)$ -curves :*

A smooth real curve  $X$  of genus  $g$  is called an  $(M - 2)$ -curve in case the real locus has exactly  $g - 1$  components. A separating pencil on  $X$  is a base point free real linear system  $g_k^1$  on  $X$  such that the support of each real divisor in  $g_k^1$  only contains real points. If  $X$  has such pencil then  $X(\mathbb{C}) \setminus X(\mathbb{R})$  is disconnected ( $X$  is called separating). A result of Gabart implies a separating  $(M - 2)$ -curve has a separating pencil of degree at most  $g$ . We show the existence of separating  $(M - 2)$ -curves having no separating pencil of degree  $g - 1$ . As a corollary, although for a separating  $(M - 1)$ -curve  $X$  the scheme  $W_{g-1}^1$  parameterizing linear systems  $g_{g-1}^1$  on  $X$  has dimension  $g - 4$ , there exist such curves having an isolated point in the real locus  $W_{g-1}^1(\mathbb{R})$ .

---

**Felipe Cucker**, *On a Problem posed by Steve Smale :*

At the request of the International Mathematical Union, in 1999, Steve Smale proposed a list of 18 problems for the mathematicians of the 21st century. The 17th of these problems asks for the existence of a deterministic algorithm computing an approximate solution of a system of  $n$  complex polynomials in  $n$  unknowns in time polynomial, on the average, in the size  $N$  of the input system. The talk gives fundamental advances in this problem including the smoothed analysis of a randomized algorithm and a deterministic algorithm working in near-polynomial (i.e.,  $N^{O(\log \log N)}$ ) average time.

Joint work with Peter Buergisser.

---

**Alex Degtyarev**, *On real determinantal quartics :*

We describe all possible arrangements of the ten nodes of a generic real determinantal quartic surface in  $\mathbb{C}\mathbb{P}^3$  with nonempty spectrahedral region.

Joint work with I. Itenberg.

---

**Charles N. Delzell**, *Eliminating nontransversal zeros in the Finiteness Theorem for open semialgebraic sets* :

Let  $R$  be a real closed field (e.g.,  $\mathbb{R}$ ), with the usual, order topology. Let  $K$  be a subfield (e.g.,  $\mathbb{Q}$ ). Below,  $f$  and  $g_{ij}$  will denote elements of  $K[X] := K[X_1, \dots, X_n]$ , and  $\{f > 0\}$  will denote  $\{x \in R^n \mid f(x) > 0\}$  (a “subbasic open s.a. set”). A subset  $S$  of  $R^n$  is called  $(K\text{-}R)\text{semialgebraic}$  (or “s.a.”) if it is a Boolean combination of sets of the form  $\{f > 0\}$ . The “Finiteness Theorem for open s.a. sets” asserts that if  $S$  is open s.a., then there are finitely many  $g_{ij}$  such that  $S$  can be written as

$$(1) \quad \bigcup_i \bigcap_j \{g_{ij} > 0\}$$

(the converse is obvious).

We call a zero  $x \in R^n$  of  $f$  *transversal* if  $f$  changes sign in every neighborhood of  $x$ ; we write  $Z_t(f)$  for the set of all transversal zeros of  $f$ , and  $Z_{nt}(f)$  for the set  $Z(f) \setminus Z_t(f)$ .

**Theorem:** *For every  $f$ , there are finitely many  $g_{ij}$  such that  $\{f > 0\}$  can be written in the form (1) with  $Z_{nt}(g_{ij}) = \emptyset$  for each  $i, j$ .*

The Theorem is proved by induction on  $n$ , and then by induction on  $\max \dim W$ , where  $W$  ranges over the “strata” of  $Z_{nt}(f)$ .

An open set  $V$  in a topological space is called *regular open* if  $V = \overline{V}^\circ$ .

For any open set  $V$ ,  $\overline{V}^\circ$  is regular open. A finite intersection of regular open sets is regular open.

**Corollary 1:** *If  $S$  is open s.a., then there are finitely many  $g_{ij}$  satisfying (1) with  $\{g_{ij} > 0\}$  regular open for each  $i, j$ .*

This answers a question of Brumfiel (1991), who had proved:

**Corollary 2:** *If  $S$  is open s.a., then there are finitely many  $g_{ij}$  such that*

$$S = \bigcup_i \left( \overline{\bigcap_j \{g_{ij} > 0\}}^\circ \right).$$

*I.e.,  $S$  is a finite union of “basically” (not necessarily basic) regular open s.a. sets.*

Corollary 2 follows easily from Corollary 1 and the paragraph before it. And Corollary 1, in turn, follows immediately from the Theorem using the Finiteness Theorem and either of the following two (obvious) propositions:

**Proposition 1:** *For every  $f$ ,  $Z_{nt}(f) = \emptyset$  iff  $\{f > 0\}$  and  $\{-f > 0\}$  are regular open.*

**Proposition 2:** *For every  $f$ ,  $\{f > 0\}$  is regular open iff  $\overline{\{f > 0\}} \setminus \{f > 0\} \subseteq Z_t(f)$ .*

**Example:** Let  $n = 2$ , and write  $(X, Y)$  instead of  $(X_1, X_2)$ . Then  $Z_{nt}(Y^2 - X^2(X - 1)) = \{(0, 0)\} \neq \emptyset$ , and hence  $\{Y^2 - X^2(X - 1) > 0\}$  is not regular open. But the latter equals

$$(\{Y(Y^2 - X^2(X - 1)) > 0\} \cap \{Y > 0\})$$

$$\cup (\{Y(Y^2 - X^2(X - 1)) < 0\} \cap \{Y < 0\}) \cup (\{X > 0\} \cap \{1 - X < 0\}) \cup \{X < 0\},$$

where each polynomial on the righthand side has only transversal zeros, as in the Theorem.

---

**Paweł Domański**, *Extension properties of real analytic sets and composition operators* :

Some properties of real analytic sets turned out to be crucial in the study of composition operators  $C_\varphi$ ,  $C_\varphi(f) = f \circ \varphi$ , acting on spaces  $\mathcal{A}(\Omega)$  of real analytic functions, where  $\varphi : \Omega \rightarrow \Omega$  is a fixed analytic map and  $\Omega$  is a real analytic manifold.

For instance, we prove that for semi-proper  $\varphi$  the image of  $\varphi$  is an analytic set with an extension property (i.e., every real analytic function on  $\varphi(\Omega)$  extends to the whole space) if and only if  $C_\varphi$  has closed range. Analogously,  $C_\varphi$  is open onto its image if and only if  $\varphi(\Omega)$  has some “semi-local” extension property and  $\varphi$  is semi-proper.

We compare these two extension properties, explain which real analytic sets satisfy these extension properties and which do not satisfy. We present some open problems and compare results for  $C_\varphi$  on spaces of real analytic functions with analogous results for operators on spaces of smooth functions.

Based on a joint work with M. Goliński (Poznań) and M. Langenbruch (Oldenburg).

**Nicolas Dutertre**, *On the topology of semi-algebraic functions on closed semi-algebraic sets* :

We consider a closed semi-algebraic set  $X \subset \mathbb{R}^n$  and a  $C^2$  semi-algebraic function  $f : \mathbb{R}^n \rightarrow \mathbb{R}$  such that  $f|_X$  has a finite number of critical points. We relate the topology of  $X$  to the topology of the sets  $X \cap \{f * \alpha\}$ , where  $*$   $\in$   $\{\leq, =, \geq\}$  and  $\alpha \in \mathbb{R}$ , and the indices of the critical points of  $f|_X$  and  $-f|_X$ . We also relate the topology of  $X$  to the topology of the links at infinity of the sets  $X \cap \{f * \alpha\}$  and the indices of these critical points. We give applications when  $X = \mathbb{R}^n$  and when  $f$  is a generic linear function.

**Ido Efrat**, *Topological spaces as spaces of  $\mathbb{R}$ -places* :

The set of  $\mathbb{R}$ -places of a field of characteristic not 2 carries a natural topology, induced from its space of orderings. Becker and Gondard asked which topological spaces are realizable in this way. We report on recent progress made on this open problem. In particular, we show that this class of spaces is closed under various topological constructions.

Joint work with Katarzyna Osiak.

**Abdelhafed Elkhadiri**, *Link between noetherianity and weierstrass division theorem on some quasianalytic local rings* :

In the setting of well behaved quasianalytic differentiable system, we prove that Weierstrass Division Theorem holds if, and only if, the system is Noetherian.

**José Fernando**, *On the polynomial and regular images of  $\mathbb{R}^n$*  :

The first part of this talk is devoted to present a panoramic view of the main results concerning the study of the polynomial and regular images of  $\mathbb{R}^n$  developed during the last 20 years. As far as we know the problem of determining the semialgebraic sets which are either polynomial or regular images of  $\mathbb{R}^n$  was firstly proposed by Gamboa in the 1990 Oberwolfach week “Reelle Algebraische Geometrie”.

In the second part of the talk we present some new results developed during the last year. We prove first that the set of points at infinite of a semialgebraic set  $S \subset \mathbb{R}^m$  which is the image of a polynomial map  $f : \mathbb{R}^n \rightarrow \mathbb{R}^m$  is connected. This result is no further true in general if  $f$  is a regular map, although it still works for a large family of regular maps that we call “quasi-polynomial maps”. We also provide new obstructions for a semialgebraic set  $S \subset \mathbb{R}^m$  to be the image of an either polynomial or regular map  $f : \mathbb{R}^n \rightarrow \mathbb{R}^m$ . Finally, we present a full geometric characterization of the 1-dimensional polynomial and regular images of  $\mathbb{R}^n$ .



---

**Séverine Fiedler-Le Touzé**, *M-curves of degree 9* :

The first part of Hilbert's sixteenth problem deals with the classification of the isotopy types realizable by real plane algebraic curves of a given degree  $m$ . For  $m = 9$  the classification of the  $M$ -curves is still wide open. After systematic constructions, Korchagin formulated three conjectures predicting that some lists of isotopy types shouldn't be realizable. We will present the current state of knowledge about these conjectures, and expose some restrictions. The method, inspired from the classical one, combines Bezout's theorem with rational curves or pencils of curves, and all of the existing results on complex orientation. The novelty here is the involvement of auxiliary cubics and quartics, and of Orevkov's complex orientation formulas.

---

**Sergey Finashin**, *Real cubics and their varieties of lines* :

I will mainly focus on the Fano variety of lines on a real cubic threefold and the related spectral curves (plane real quintics with a Spin structure).

---

**Andrei Gabrielov**, *Semi-monotone sets and triangulation of tame monotone families* :

Let  $S(t)$ , for  $t > 0$ , be a monotone (decreasing) family of compact sets in a compact subset  $K$  of  $\mathbb{R}^n$ . Both  $S(t)$  and  $K$  are assumed to be definable in an o-minimal structure (for example, real semialgebraic). The following problem emerges from a conjecture formulated by Gabrielov and Vorobjov (2009) in connection with their work on approximation of a definable set by homotopy equivalent compact sets: Construct a triangulation of  $K$  so that restriction of  $S(t)$  to each open simplex is equivalent to one of the  $1 + 2^n$  "standard" families. The list of standard families is based on lex-monotone Boolean functions in  $n$  Boolean variables. This can be done for  $n < 4$ . A weaker conjecture claims that  $K$  admits a regular cell decomposition such that restriction of  $S(t)$  to each  $k$ -cell is a family of regular  $k$ -cells, and its boundary is a family of regular  $(k - 1)$ -cells. To prove this conjecture, Basu, Gabrielov and Vorobjov (2010) introduced semi-monotone sets, a generalization of convex sets. Definable semi-monotone sets are PL-regular cells. They are related to regular Boolean functions, for which the result of any quantifier elimination does not depend on the order of quantifiers.

Joint work with S. Basu and N. Vorobjov.

---

**Riccardo Ghiloni**, *The principle of moduli flexibility in Real Algebraic Geometry* :

This talk deals with deformations of algebraic structures in the *purely real* setting.

The notion of deformation of the complex analytic structure of a given compact complex analytic manifold  $M$  has been studied since the time of Riemann, who considered the 1-dimensional case. In simplest terms, a deformation of  $M$  is a family  $\{M_t\}_{t \in B}$  of compact complex analytic manifolds, parametrized by a domain  $B$  of some  $\mathbb{C}^n$ , depending analytically on  $t \in B$ , such that  $M_{t_0} = M$  for some  $t_0 \in B$ . In this context, a first basic problem is to compute the maximum number of effective parameters on which a deformation of  $M$  can depend. As discovered by Kodaira, Spencer and Kuranishi, such a maximum number is *finite* for each compact complex analytic manifolds.

In the setting of complex algebraic geometry, the notion of deformation has a different, more algebraic, nature. In fact, it is deeply connected with the moduli problem; that is, the problem of finding spaces, called moduli spaces, that classify, up to complex biregular isomorphism, all the projective complex algebraic manifolds with assigned numerical invariants or additional structures as the polarizations. Anyway, we can assert again that

the complex algebraic structure of every projective complex algebraic manifold can be deformed by an at most *finite* number of effective parameters.

In complex algebraic geometry, a real manifold is usually defined as a pair  $(X, \sigma)$  in which  $X$  is a projective complex algebraic manifold and  $\sigma : X \rightarrow X$  is an anti-holomorphic involution. We call  $(X, \sigma)$  *real-complex* algebraic manifold and  $\sigma$  *real-complex* algebraic structure on  $X$ . In this real-complex setting, we do not know if the real-complex algebraic structure of *every* real-complex algebraic manifold can be deformed by an at most finite number of effective parameters. However, if the real isomorphic class of a given real-complex algebraic manifold  $(X, \sigma)$  belongs to a (coarse) real moduli space  $\mathcal{R}$ , then the maximum number of effective parameters on which a deformation of  $(X, \sigma)$  can depend is  $\leq \dim \mathcal{R}$  and hence is finite. A shining example is the one of real-complex curves.

In this talk, we treat the notion of deformation of real algebraic structures from the point of view of *purely real* algebraic geometry; that is, of the real algebraic geometry systematically studied, as an independent discipline, in the foundational book “Real Algebraic Geometry” of Bochnak, Coste and Roy. As far as we know, this is the first time that such a treatment has been done.

The main purpose of this talk is to make rigorous the following informal principle, which is in sharp contrast with the complex analytic, complex algebraic and real-complex algebraic cases.

*Principle of real algebraic moduli flexibility.* The algebraic structure of every real algebraic manifold of positive dimension can be deformed by an arbitrarily large number of effective parameters.

Joint work with Edoardo Ballico.

**Dima Grigoriev**, *Complexity of resolution of singularities* :

We estimate the complexity of Hironaka’s desingularization algorithm in terms of Grzegorzczuk’s classes (the latter being a hierarchy of primitive-recursive functions). The main conclusion is that the dimension of a variety brings the principal contribution into the complexity bound.

Joint work with E.Bierstone, P.Milman, J.Włodarczyk.

**Viatcheslav Kharlamov**.

**Igor Klep**, *The Convex Nichtnegativstellensatz in a free algebra* :

Given linear matrix inequalities (LMIs)  $L_1$  and  $L_2$  it is natural to ask: does one dominate the other? That is,

$$(Q) \quad \text{does } L_1(x) \succeq 0 \text{ imply } L_2(x) \succeq 0?$$

In this talk we describe a natural relaxation of an LMI, based on substituting matrices for the variables  $x_j$ . With this relaxation, the domination question (Q) has an elegant answer. Indeed, for our “matricial” relaxation, a positive answer to (Q) is equivalent to the existence of matrices  $V_j$  such that

$$(A) \quad L_2(x) = V_1^T L_1(x) V_1 + \dots + V_r^T L_1(x) V_r.$$

The relaxed LMI domination problem is equivalent to a classical problem in operator algebras. Namely, the problem of determining if a linear map is *completely positive*.

Algebraic certificates for positivity, such as (A) for LMIs, are typically called Positivstellensätze. We shall also give a positivity certificate for polynomials:  $p$  is *positive*

*semidefinite* on the matricial LMI domain  $L(X) \succeq 0$  if and only if it has a weighted sum of squares representation with optimal degree bounds:

$$(B) \quad p(x) = s(x)^T s(x) + \sum_j f_j(x)^T L(x) f_j(x),$$

where  $s(x), f_j(x)$  are vectors of polynomials of degree no greater than  $\deg(p)/2$ .

A main ingredient of the proof is an analysis of extensions of *Hankel matrices*.  
Based on joint papers with J.W. Helton and S. McCullough.

**Manfred Knebusch**, *Tropical and supertropical degenerations of a commutative ring* :

If  $R$  is a commutative ring, then degeneration of  $R$  to a “simpler” commutative ring usually means moding out the congruence relation by an ideal. In particular a field does not have such a degeneration. Things become more interesting if we allow degeneration to semirings. The simplest such degenerations are provided by  $m$ -valuations (= monoid valuations). They can be interpreted as a modest generalization of the valuations on  $R$  in the sense of Bourbaki (Alg. comm. Chap. 6). An  $m$ -valuation is a multiplicative and subadditive map  $v : R \rightarrow M$  to a totally ordered semiring of very special kind, a so-called “bipotent” semiring.

An  $m$ -valuation  $v : R \rightarrow M$  can be “covered” by a supervaluation  $\varphi : R \rightarrow U$  in various ways. This means degenerating  $R$  to a multiplicative submonoid of a “supertropical” semiring  $U$ . Applying a supervaluation  $\varphi$  to the coordinates of  $R$ -valued points of an affine scheme  $V$  over  $R$  means degenerating  $V(R)$  in a less coarse way than by applying  $v$ . The various supertropical degenerations of  $V(R)$  provide a refinement of tropical geometry. If time allows I will give natural examples of  $m$ -valuations and supervaluations in the talk.

Joint work with Zur Izhakian and Louis Rowen.

**Wojciech Kucharz**, *Transcendental submanifolds of projective space* :

A smooth submanifold  $M$  of real projective  $n$ -space  $\mathbb{P}^n(\mathbb{R})$  is said to be of algebraic type if it is isotopic in  $\mathbb{P}^n(\mathbb{R})$  to the set of real points of a nonsingular complex algebraic subset of  $\mathbb{P}^n(\mathbb{C})$  defined over  $\mathbb{R}$ ; otherwise  $M$  is said to be transcendental. If  $\text{codim } M = 1$  or  $2 \dim M < n$ , then  $M$  is of algebraic type. In particular, every submanifold of dimension 1 is of algebraic type. It is not at all obvious that transcendental submanifolds exist. I will give an explicit construction of transcendental submanifolds of any dimension greater than 3 and of any codimension greater than 1. The result is particularly nice for submanifolds of codimension 2.

**Aaron Kunert**, *Faces of cones of nonnegative quartics* :

We study the facial structure of cones of positive semidefinite quartics. For certain types of faces we will name an ambient vector space and give a criterion of full-dimensionality in this vector space. This leads to an estimate of occurring dimensions of faces. We will compare them to dimensions of corresponding faces of the cone of sums of squares and point out explicit dimensional differences between these cones. As an application we can list all faces of the cone of ternary quartics and thereby we obtain a complete description of the facial structure of this cone. In particular this will give us an alternative proof of Hilbert’s theorem.

**Noa Lavi**, *Some positivstellensatz in real closed valued fields* :

The purpose of this talk is to give a generalization of Hilbert's seventeenth problem in real closed valued fields, that is, to give an algebraic characterization, for a definable set, of the set of polynomials which get only non-negative values on it. We give a general characterization of the positive semi-definite polynomials for any definable set with a Ganzstellensatz, and we also give a representation of those polynomials in the sense of Hilbert 17th problem (that is, in terms of sums of squares) for definable sets from a certain kind.

---

**Antonio Lerario**, *Systems of Quadratic Inequalities* :

Systems of quadratic inequalities are very flexible objects in mathematics, e.g any system of polynomial equations can be reduced to a system of quadratic equations by substitutions. Thus the set  $X$  of the solutions of a system of quadratic inequalities can describe a very large class of semi-algebraic sets (the complexity of  $X$  is hidden in the number of linearly independent inequalities). To study such a system we focus on the dual object: the convex hull, in the space of all real quadratic forms on  $\mathbb{R}^n$ , of those quadratic forms involved in the system ( $n$  is the number of variables in the system). It turns out that the homology of  $X$  is determined by the arrangement of this convex hull with respect to the cone of degenerate forms. This approach allows to efficiently compute homology for a very big number of variables  $n$  as long as the number of linearly independent inequalities is limited. Moreover, it works also for systems of integral quadratic inequalities, i.e. in the infinite dimension, beyond the semi-algebraic context. The calculations are organized in a spectral sequence whose member  $E_2$  and the differential  $d_2$  have a simple clear geometric interpretation.

Joint work with A. Agrachev.

---

**Thierry Limoges**, *Products of real weight filtrations* :

The weight filtration for real algebraic varieties has been developed by McCrory and Parusiński, by analogy with Deligne's weight filtration for complex algebraic varieties. They associate to each variety  $X$  a filtered chain complex  $\mathcal{G}_\bullet C_*(X)$  which computes the Borel-Moore homology  $H_*^{BM}(X)$ , and a spectral sequence  $E^r(X)$ , functorial and additive for closed inclusions. The filtration is build using semi-algebraically constructible functions. We explain how the operation of cross product allows us to compare the respective filtered complexes and spectral sequences for varieties  $X, Y$  and their product  $X \times Y$ . We have a dual cohomological theory on  $H_c^*(X)$ , which gives informations about cup and cap products of  $X$ .

---

**Henri Lombardi**, *Effective Positivstellensatz* :

In this talk, we speak about a work in progress with D. Perrucci and M.-F. Roy about bounds on the real Positivstellensatz. A Positivstellensatz is a rational algebraic certificate of impossibility for a system of polynomial equalities and inequalities in a real closed field. This certificate can also be seen as a very elementary proof of impossibility within the theory of ordered domains. Previous algorithmic proofs of the Positivstellensatz are based upon very long elementary proofs of impossibility and lead to very large bounds on the degree of the certificate. More geometric proofs of impossibility lead to testing emptiness through algorithms of simple exponential size. But these "short" algorithmic proofs are very unlikely transformed in algebraic certificates. Finding a "good" algorithm for the Positivstellensatz is similar to finding a short and elementary proof for impossibilities within the theory of ordered domains. It happens that this could be achieved through a convenient variation on proofs through CAD (cylindric algebraic decomposition). But

usual proofs that CAD work rely on the subtle notion of semialgebraic connectedness, which is not defined as a first order concept. So we have to replace connectedness arguments by a convenient use of Hermite theory of signature of real quadratic forms, which is based on the existence of complex roots. From the point of view of algebraic certificates, existence has to be replaced by a kind of dual notion, called “weak existence”. It happens that weak existence of complex roots lead to triple exponential bounds. Combined with the usual double exponential bounds for CAD, we obtain, hopefully, 5-exponential bounds for the Positivstellensatz.

---

**Frédéric Mangolte**, *Topologie des variétés algébriques réelles de dimension 3* :

La topologie des variétés algébriques réelles de dimension 3 est de mieux en mieux connue. Depuis que Kollar, il y a une dizaine d’années, a ouvert une voie d’étude grâce une solution du MMP sur  $\mathbb{R}$ , les avancées ont été nombreuses. Dans cet exposé, je parlerai de plusieurs conjectures de Kollar résolues depuis. On se rapproche d’une classification des 3-variétés uniréglées et des 3-variétés rationnellement connexes. Je décrirai l’état de l’art concernant ce problème, et en particulier mes contributions obtenues en collaboration avec J. Huisman, F. Catanese, et J.-Y. Welschinger.

---

**Arnaud Moncet**, *Real versus complex volumes on real algebraic surfaces* :

Let  $X$  be a real algebraic surface. The comparison between the volume of  $D(\mathbb{R})$  and  $D(\mathbb{C})$  for ample divisors  $D$  brings us to define the concordance  $\alpha(X)$ , which is a number between 0 and 1. This number equals 1 when the Picard number  $\rho(X_{\mathbb{R}})$  is 1, and for some surfaces with a “quite simple” nef cone, e.g. Del Pezzo surfaces. For abelian surfaces,  $\alpha(X)$  is 1/2 or 1, depending on the existence or not of positive entropy automorphisms on  $X$ . In the general case, the existence of such an automorphism gives an upper bound for  $\alpha(X)$ , namely the ratio of entropies  $h_{top}(f|X(\mathbb{R}))/h_{top}(f|X(\mathbb{C}))$ . Moreover  $\alpha(X)$  is equal to this ratio when the Picard number is 2. An interesting consequence of the inequality is the non-density of  $\text{Aut}(X_{\mathbb{R}})$  in  $\text{Diff}(X(\mathbb{R}))$  as soon as  $\alpha(X) > 0$ . Finally we show, thanks to this upper bound, that there exist K3 surfaces with arbitrary small concordance, considering a deformation of a singular surface of tridegree  $(2, 2, 2)$  in  $\mathbb{P}^1 \times \mathbb{P}^1 \times \mathbb{P}^1$ .

---

**Seydou Moussa**, *Singularités des robots 6-UPS* :

L’exposé a pour but de présenter une étude géométrique des singularités des robots parallèles 6 degrés de liberté de type 6-UPS. Ce dernier présente beaucoup de similarités avec les robots parallèles plans 3-RPR. En utilisant un espace de travail modifié et une paramétrisation de la surface des configurations singulières, le Professeur Michel Coste a donné en particulier une preuve géométrique simple du fait qu’un robot 3-RPR générique a deux aspects (deux composantes connexes). Nous nous proposons d’utiliser cette méthode dans l’étude du robot 6-UPS.

---

**Tim Netzer**, *Polynomials with and without determinantal representations* :

The problem of writing real zero polynomials as determinants of linear matrix polynomials has recently attained a lot of attention. It is in fact the algebraic question behind the geometric problem to characterize spectrahedra. Spectrahedra are the feasible sets of semidefinite optimization problems, and thus of great importance. I will discuss positive and negative results concerning the problem of finding determinantal representations of polynomials.

---

**Ha Nguyen**, *Polynomials Non-negative on Strips and Half-strips* :

Recently, M. Marshall answered a long-standing question in real algebraic geometry by showing that if  $f \in \mathbb{R}[x, y]$  and  $f \geq 0$  on the strip  $[0, 1] \times \mathbb{R}$ , then  $f$  has a representation  $f = \sigma_0 + \sigma_1 x(1 - x)$ , where  $\sigma_0, \sigma_1 \in \mathbb{R}[x, y]$  are sums of squares.

Representation theorems of this type have a rich and remarkable history, going back at least to Hilbert. In this talk, we give the background to Marshall's result, and our generalizations to other non-compact semialgebraic subsets of  $\mathbb{R}^2$ . Our results give many new examples of non-compact semialgebraic sets in  $\mathbb{R}^2$  for which all polynomials that are non-negative on the set can be characterized.

---

**Andreea Nicoara**, *The Non-Noetherianity of the Denjoy-Carleman Rings of Germs* :

A ring  $R$  of Denjoy-Carleman quasianalytic germs of functions that is stable under derivation and strictly contains the ring of analytic germs is not Noetherian in dimension 2 or higher. This result settles a question open since 1976 when Childress proved such rings fail Weierstrass Division. The argument uses a stronger version of Artin Approximation.

Joint work with Liat Kessler (Technion).

---

**Krzysztof Nowak**, *On the singular locus of sets definable in a quasianalytic structure* :

Given a quasianalytic structure, I prove that the singular locus of a quasi-subanalytic set  $E$  is a closed quasi-subanalytic subset of  $E$ . I rely on some stabilization effects linked to Gateaux differentiability and formally composite functions. An essential ingredient of the proof is a quasianalytic version of Glaeser's composite function theorem, presented in my earlier paper.

---

**Adamou Otto**, *Analysis of a two-strain transmission model with vaccination using computer algebra* :

We present a typical example of a compartmental transmission model that can be dealt with algebraically. We use exact methods from real algebraic geometry and computer algebra to find all the equilibria of the ODE system describing the model and to study their stability as well as their bifurcations.

The model concerns a host population, a part of its individuals are under antibiotic (Ab) treatment against a two-strain bacterial pathogen. Individuals who are not under Ab treatment can be colonized by an antibiotic-susceptible (Ab-S) strain or by an antibiotic-resistant (Ab-R) strain of a bacterial pathogen, but not by both at the same time (i.e., maximal competition), while those under antibiotic treatment can only be colonized by the Ab-R strain. We assume that there is a fitness cost for resistance such that the Ab-R strain is somewhat less transmissible than the Ab-S strain. The host population is subdivided into 7 compartments representing the fractions of the population in each state, 4 states for individuals not under Ab treatment: susceptible ( $S$ ), colonized by the Ab-S strain ( $I_1$ ) and colonized by the Ab-R strain ( $I_2$ ), the individuals who are in the vaccinated state not under antibiotic treatment. those individuals are assumed to have a temporary complete immunity to infection by the 2 strains ( $V$ ), and 3 states for individuals under Ab treatment: susceptible ( $T$ ), and colonized by the Ab-R strain ( $T_2$ ), the individuals who are in the vaccinated state currently under antibiotic treatment. Those individuals are assumed to have a temporary complete immunity to infection by the 2 strains ( $V_T$ ). We give below the transfer diagram of the model.

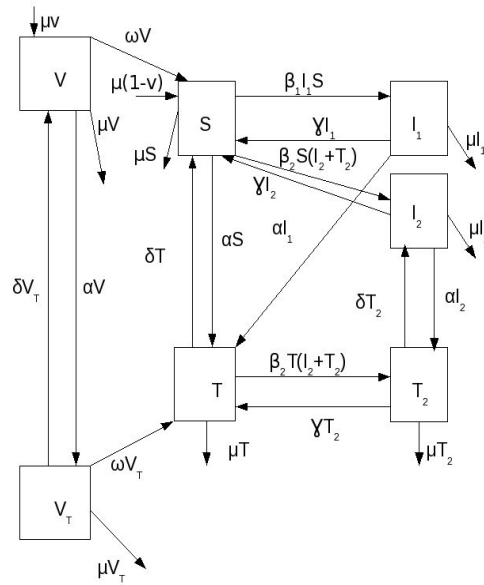

The model has a unique disease free equilibria and three other equilibria. We give a complete characterization of their existence and stability. We also show that all codimension-one bifurcations are transcritical.

Joint work with M. EL Kahoui, M.-F. Roy and T. Van Effelterre.

**Franklin Vera Pacheco**, *Resolution of singularities of pairs preserving semi-simple normal crossings* :

A partial desingularization consists in removing all singularities, except for those of certain class  $S$ , with a proper birational map that is an isomorphism over the points already in  $S$ . For example, if  $S$  consists only of the smooth *singularities*, then a partial desingularization in this sense corresponds to the usual (strong) resolution of singularities. For other classes of singularities this problem has also been studied, solved or proved impossible, e.g. simple normal crossings, normal crossings, normal singularities, rational singularities... It was asked by János Kollár the existence of a partial desingularization preserving the semi simple normal crossings singularities of a pair. This is the analogous of simple normal crossings singularities in a non-normal ambient space. We show how to produce this partial desingularization by using a general philosophy applicable to some of these problems.

Joint work with Edward Bierstone.

**Daniel Pecker**, *On the minimum degree of a polynomial knot representing a given knot* :

A polynomial knot is a polynomial embedding of the real line into Euclidean space. The study of the space of polynomial knots of a given degree  $d$  is achieved only for  $d \leq 4$ . We study a converse problem: given a knot, what is the minimum degree of a polynomial knot representing it ? We give answers for the simplest knots, and for some infinite families of knots.

---

**Albrecht Pfister**, *An elementary and constructive proof of Hilbert's theorem on ternary quartics* :

We present a new proof of Hilbert's theorem which is elementary in the sense that it uses only undergraduate methods from algebra, analysis and topology including the implicit function theorem. The proof is also essentially constructive and shows that there are at most 8 inequivalent representations as a sum of 3 squares for a given positive semidefinite quartic over the reals.

Joint work with Claus Scheiderer.

---

**Daniel Plaumann**, *Quartic curves and their bitangents* :

We will consider two types of representations of real ternary quartics: 1) As determinants of symmetric 4x4-matrices with linear entries. 2) As sums of three (signed) squares. We will discuss explicit constructions of these representations, using the classical theory of bitangents. We also address more recent connections to spectrahedra and semidefinite programming.

Joint work with Bernd Sturmfels and Cynthia Vinzant.

---

**Lucas Prelli**, *O-minimal sheaf theory* :

O-minimal sheaf theory generalize Delfs semi-algebraic and real algebraic sheaf theory as well as Kashiwara-Schapira sheaf theory on the (globally) sub-analytic site. The formalism of Grothendieck's six operations on o-minimal sheaves that we propose to develop generalizes also similar works in the topological context (Verdier) and the subanalytic context (Kashiwara-Schapira and Prelli). Besides the interest that this theory has on its own, it will provide the main tools for the cohomological approach to problems related to algebraic analysis on one side and o-minimal geometry on the other.

Joint work with M. Edmundo.

---

**Armin Rainer**, *Quasianalytic and Lipschitz perturbation theory for normal operators* :

We study the regularity of the eigenvalues and the eigenvectors of families of normal operators. This is evidently connected to the regularity of the roots of complex polynomials. Surprisingly though, the eigenvalues and eigenvectors possess much better regularity properties than the roots. For instance, we shall see that the eigenvalues and eigenvectors of a real analytic (or, even quasianalytic) family of normal matrices may be desingularized by means of local blow-ups; for the roots, in addition, we must substitute powers. Moreover, any continuous eigenvalue of a Lipschitz family of normal operators is Lipschitz; the roots need not be Lipschitz even if the coefficients are polynomial. We will also state infinite dimensional versions of our results, i.e., for normal operators in a Hilbert space with compact resolvents and common domain of definition.

---

**Tomas Recio**, *Generalizing circles over algebraic extensions* :

Partially supported by the project MTM2005-08690-C02-01/02.

This contribution deals with a family of spatial rational curves that were introduced by Carlos Andradas, Tomás Recio, and J. Rafael Sendra at *Base field restriction techniques for parametric curves*, (Proceedings of the 1999 International Symposium on Symbolic and Algebraic Computation (Vancouver, BC), ACM, 1999, pp. 17–22), under the name of



hypercircles, as an algorithmic tool in the context of simplifying, if possible, the coefficients of the rational functions of a given parametrization of an algebraic variety.

The simplest hypercircles should be the circles themselves. Circles live on a real plane. We can think of the real plane as the field of complex numbers  $\mathbb{C}$ , an algebraic extension of the reals  $\mathbb{R}$  of degree 2. Analogously, we can consider a characteristic zero base field  $\mathbb{K}$  and an algebraic extension of degree  $n$ ,  $\mathbb{K}(\alpha)$ . Let us identify  $\mathbb{K}(\alpha)$  as the vector space  $\mathbb{K}^n$ , via the choice of a suitable base, such as the one given by the powers of  $\alpha$ . This is the framework in which hypercircles are defined.

Circles are real rational curves. This means that there are two real rational functions  $\phi(t) = (\phi_1(t), \phi_2(t))$  whose image cover almost all the points of the circle. Every proper (almost one-to-one) rational parametrization of a circle verifies that  $\phi_1(t) + i\phi_2(t) = \frac{at+b}{ct+d} \in \mathbb{C}(t) \setminus \mathbb{C}$ , which defines a conformal mapping  $u : \mathbb{C} \rightarrow \mathbb{C}$ . Moreover, if we identify  $\mathbb{C}$  with  $\mathbb{R}^2$ , the image of the real axis  $(t, 0)$  under  $u$  is exactly the circle parametrized by  $\phi(t)$ . Conversely, let  $u(t) = \frac{at+b}{ct+d} \in \mathbb{C}(t)$  be a unit of the near-ring  $\mathbb{C}(t)$  under the composition operator. If  $c \neq 0$  and  $d/c \notin \mathbb{R}$  then, the closure of the image by  $u$  of the real axis is a circle. Otherwise, it is a line.

This method to construct circles generalizes easily to algebraic extensions. Namely, let  $u(t) = \frac{at+b}{ct+d}$  be a unit of  $\mathbb{K}(\alpha)(t)$  (i.e. verifying that  $ad - bc \neq 0$ ). Let us identify  $\mathbb{K}(\alpha)$  with  $\mathbb{K}^n$  and let  $u$  be the map

$$u : \begin{matrix} \mathbb{K}(\alpha) \approx \mathbb{K}^n \\ t \end{matrix} \rightarrow \begin{matrix} \mathbb{K}(\alpha) \approx \mathbb{K}^n \\ u(t) \end{matrix}.$$

Then, the Zariski-closure of the image of the axis  $(t, 0, \dots, 0)$  under the map  $u$  is a rational curve in  $\mathbb{K}^n$ . These curves are, by definition, our hypercircles.

**Example 0.1.** Let us consider the algebraic extension  $\mathbb{Q} \subseteq \mathbb{Q}(\alpha)$ , where  $\alpha^3 + 2\alpha + 2 = 0$ . The unit  $\frac{t-\alpha}{t+\alpha}$  has an associated hypercircle parametrized by

$$\phi(t) = \left( \frac{t^3 + 2t + 2}{t^3 + 2t - 2}, \frac{-2t^2}{t^3 + 2t - 2}, \frac{2t}{t^3 + 2t - 2} \right)$$

Let  $\mathbb{K}$  be a field of characteristic zero,  $\mathbb{K} \subseteq \mathbb{L}$  a finite algebraic extension of degree  $n$  and  $\mathbb{F}$  the algebraic closure of  $\mathbb{K}$  and  $\alpha$  be a primitive element of  $\mathbb{L}$  over  $\mathbb{K}$ . As it stands, the definition of a hypercircle  $\mathcal{U}$  depends on a given unit  $u(t)$  and on a primitive generator  $\alpha$  of an algebraic extension  $\mathbb{K} \subseteq \mathbb{L}$ . But notice that, given a unit  $u(t) \in \mathbb{L}(t)$  and two different primitive elements  $\alpha$  and  $\beta$  of the extension  $\mathbb{K} \subseteq \mathbb{L}$ , we can expand the unit in two different ways  $u(t) = \sum_{i=0}^{n-1} \alpha^i \phi_i(t) = \sum_{i=0}^{n-1} \beta^i \psi_i(t)$ . The hypercircles  $\mathcal{U}_\alpha \simeq (\phi_0(t), \dots, \phi_{n-1}(t))$  and  $\mathcal{U}_\beta \simeq (\psi_0(t), \dots, \psi_{n-1}(t))$  generated by  $u(t)$  are different curves in  $\mathbb{F}^n$ , see Example 0.2.

**Example 0.2.** Let us consider the algebraic extension  $\mathbb{Q} \subseteq \mathbb{Q}(\alpha)$ , where  $\alpha^4 + 1 = 0$ . Let us take the unit  $u(t) = \frac{t-\alpha}{t+\alpha}$ . By normalizing  $u(t)$ , we obtain the parametrization  $\phi(t)$  associated to  $u(t)$ :

$$\phi(t) = \left( \frac{t^4 - 1}{t^4 + 1}, \frac{-2t^3}{t^4 + 1}, \frac{2t^2}{t^4 + 1}, \frac{-2t}{t^4 + 1} \right).$$

This hypercircle  $\mathcal{U}_\alpha$  is the zero set of  $\{X_1X_2 - X_3X_0 - X_3, X_1^2 + X_3^2 - 2X_2, X_1X_0 + X_2X_3 - X_1, X_0^2 + X_3X_1 - 1\}$ . Now, we take  $\beta = \alpha^3 + 1$ , instead of  $\alpha$ , as the primitive element of  $\mathbb{Q}(\alpha) = \mathbb{Q}(\beta)$ . The same unit  $u(t)$  generates the  $\beta$ -hypercircle  $\mathcal{U}_\beta$  parametrized by

$$\psi(t) = \left( \frac{t^4 + 2t^3 - 2t^2 + 2t - 1}{t^4 + 1}, \frac{-6t^3 + 4t^2 - 2t}{t^4 + 1}, \frac{6t^3 - 2t^2}{t^4 + 1}, \frac{-2t^3}{t^4 + 1} \right),$$

which is different to  $\mathcal{U}_\alpha$ ; note that  $\psi(1) = (1, -2, 2, -1)$  that does not satisfy the equation  $X_0^2 + X_3X_1 - 1 = 0$  of  $\mathcal{U}_\alpha$ .

Nevertheless, let  $\mathcal{A} \in \mathcal{M}_{n \times n}(\mathbb{K})$  be the matrix of change of basis from  $\{1, \alpha, \dots, \alpha^{n-1}\}$  to  $\{1, \beta, \dots, \beta^{n-1}\}$ . Then,  $\mathcal{A}(\phi_0(t), \dots, \phi_{n-1}(t))^t = (\psi_0(t), \dots, \psi_{n-1}(t))^t$ . That is, it carries one of the curve onto the other. Thus,  $\mathcal{U}_\alpha$  and  $\mathcal{U}_\beta$  are related by the affine transformation induced by the change of basis and, so, they share many important geometric properties.

The aim of this talk is to extend, to the case of hypercircles, some of the specific properties of circles. We will show that hypercircles are precisely, via  $\mathbb{K}$ -projective transformations, the rational normal curve of a suitable degree. We will also obtain a complete description of the points at infinity of these curves (generalizing the cyclic structure at infinity of circles). We will characterize hypercircles as those curves of degree equal to the dimension of the ambient affine space and with infinitely many  $\mathbb{K}$ -rational points, passing through these points at infinity. If time permits, we will give explicit formulae for the parametrization and implicitation of hypercircles.

Besides the intrinsic interest of this very special family of curves, we think the understanding of its properties has a direct application to the simplification of parametrizations problem.

The talk will be based on a recent paper by R. Sendra, L.F. Tabera, C. Villarino and the author: *Generalizing circles over algebraic extensions*, Mathematics of Computation, Volume 79, Number 270, April 2010, Pages 1067–1089.

**Bruce Reznick**, *Sums of fourth powers of real polynomials* :

What are necessary and sufficient conditions on a real polynomial  $p(x)$  in one variable so that there exist polynomials  $h_k(x)$  so that  $p = \sum_k h_k^4$ ? We will present some partial results and conjectures.

**Jean-Jacques Risler**, *On the curvature of the Real Amoeba*

For a real smooth algebraic curve  $A \subset (\mathbb{C}^*)^2$ , the amoeba  $\mathcal{A} \subset \mathbb{R}^2$  is the image of  $A$  under the map  $\text{Log} : (x, y) \mapsto (\log |x|, \log |y|)$ . We describe an universal bound for the total curvature of the real amoeba  $\mathcal{A}_{\mathbb{R}, A}$  and we prove that this bound is reached if and only if the curve  $A$  is a simple Harnack curve in the sense of Mikhalkin.

Joint work with Mikael Passare.

**Claus Scheiderer**, *Positive polynomials and sums of hermitian squares* :

In 1968, Quillen proved that every real polynomial that is strictly positive on a Euclidean sphere in complex  $n$ -space  $\mathbb{C}^n$  coincides with a sum of hermitian squares on that sphere. We give an abstract characterization of all real algebraic subsets  $X$  of  $\mathbb{C}^n$  on which every strictly positive polynomial is a hermitian sum of squares and discuss the relation with commuting subnormal tuples of operators. We also plan to discuss extensions of the results to semi-algebraic subsets of  $\mathbb{C}^n$ .

Joint work with Mihai Putinar.

**Marco Schlichting**, *The Mayer-Vietoris principle for Grothendieck-Witt groups of schemes* :

Extending Knebusch's definition of the Grothendieck-Witt group of a scheme to categories of chain complexes, and in analogy with algebraic K-theory, we define higher Grothendieck-Witt groups of a scheme (or category of chain complexes) as the homotopy groups of an explicitly defined topological space. We show that an open covering of a scheme with an ample family of line-bundles gives rise to a Mayer-Vietoris long exact of the corresponding higher Grothendieck-Witt groups. The main point here is that all this works even when the scheme is singular and 2 is not invertible in the ring of regular functions.

---

**Tamara Servi**, *Preparation theorem and quantifier elimination for quasi-analytic classes* :

We consider the structures generated by a family of quasi-analytic algebras of functions which have asymptotic expansion as generalised power series. We show that these structures are  $o$ -minimal and polynomially bounded. Furthermore, we prove that van den Dries' and Speissegger's preparation theorem for definable functions admits in these structures an "explicit" form, from which we deduce a quantifier elimination result (in a reasonable language).

Joint work with J.-P. Rolin.

---

**Masahiro Shiota**, *By replacement of real closed fields* :

By replacement of real closed fields we can sometimes prove globally problems on real algebraic geometry when they are already proved locally by algorithm. This is the case for the second Łojasiewicz inequality. Let  $f$  be a polynomial function on  $\mathbb{R}^n$ . Then there exist a semialgebraic neighborhood  $V$  of  $f^{-1}(0)$  in  $\mathbb{R}^n$  and a number  $\theta$  such that  $0 < \theta < 1$  and  $|f(x)|^\theta \leq \sum_{i=1}^n |\frac{\partial f}{\partial x_i}(x)|$  for  $x \in V$ .

---

**Rainer Sinn**, *SO(2)-Orbitopes* :

An  $SO(2)$ -orbitope is the convex hull of an orbit under some linear action of  $SO(2)$  on a finite dimensional real vector space. Such a set is always a compact convex semi-algebraic set. We will study the question whether or not it is basic closed, i.e. defined by a finite number of simultaneous polynomial inequalities. We will be particularly interested in the case of the so-called Barvinok-Novik orbitopes. This work is in progress.

---

**Ahmed Srhir**, *Łojasiewicz's exponents in  $o$ -minimal structures* :

We prove the rationality of the Łojasiewicz's exponent for definable functions in polynomially bounded  $o$ -minimal structures with certain conditions. In the parametric case, we show that the parameter space can be splitting into finitely many definable subsets on each of which the Łojasiewicz's exponent is constant.

---

**Zbigniew Szafraniec**, *Quadratic forms and the intersection number for polynomial immersions* :

Several important invariants associated with polynomial mappings and real algebraic sets may be expressed in terms of signatures of appropriate quadratic forms.

There will be presented such methods of computing the intersection number for polynomial immersions.

---

**Carlos Ueno**, *On convex polyhedra as regular images of  $\mathbb{R}^n$*  . :

We show that convex polyhedra in  $\mathbb{R}^n$  and their interiors are images of regular maps  $\mathbb{R}^n \rightarrow \mathbb{R}^n$ . As a main ingredient in the proof we construct, given an  $n$ -dimensional, bounded, convex polyhedron  $K \subset \mathbb{R}^n$  and a point  $p \in \mathbb{R}^n \setminus K$ , a suitable partition of the boundary  $\partial K$  of  $K$  determined by  $p$  and compatible with the interiors of the faces of  $K$ . Finally, we also prove that closed balls in  $\mathbb{R}^n$  and their interiors are images of regular maps  $\mathbb{R}^n \rightarrow \mathbb{R}^n$ .

---

**Guillaume Valette**, *De Rham theorems on singular varieties* :

I will explain how some recent results of mine on the Lipschitz geometry of subanalytic sets make it possible to extend some theorems of differential geometry, such as the de Rham theorem, to the framework of (possibly singular) subanalytic varieties.

---

**Nicolai Vorobjov**, *Approximation of definable sets by compact families* :

We suggest a construction for approximating a large class of sets, definable in an o-minimal structure over the reals, by compact sets. The class includes sets defined by arbitrary Boolean combinations of equations and inequalities, and images of such sets under a large class of definable maps, e.g., projections. Based on this construction, we prove  $k$ -equivalence of definable sets to compact definable sets. This leads to a refinement of the known upper bounds on Betti numbers, and a proof of similar upper bounds, individually for different Betti numbers, for images under arbitrary continuous definable maps.

Joint work with Andrei Gabrielov.





# **PARTICIPANTS**



Family name	First name	Institute	Country	E-mail
Acquistapace	Francesca	Università di Pisa	Italy	acquistf@dm.unipi.it
Adamou	Otto	/	Niger	otto_adamou@yahoo.com
Adamus	Janusz	University of Western Ontario / Jagiellonian University	Canada	jadamus@uwo.ca
Alonso	Mariemi	Complutense University of Madrid	Spain	m_alonso@mat.ucm.es
Amidou	Morou	Université de Niamey	Niger	moorou_a@yahoo.fr
Astier	Vincent	University College Dublin	Ireland	vincent.astier@ucd.ie
Bardet	Alexandre	Université d'Angers	France	bardet@math.univ-angers.fr
Barone	Salvador	Purdue University	USA	sbarone@math.purdue.edu
Basu	Saugata	Purdue University	USA	sbasu@math.purdue.edu
Bekka	Karim	Université de Rennes 1 - IRMAR	France	karim.bekka@univ-rennes1.fr
Bertrand	Benoît	Institut de math. de Toulouse / IUT de Tarbes	France	benoit.bertrand@math.univ-toulouse.fr
Biborski	Iwo	Jagiellonian University	Poland	Iwo.Biborski@im.uj.edu.pl
Bihan	Frédéric	Université de savoie	France	frederic.bihan@univ-savoie.fr
Bilski	Marcin	Jagiellonian University	Poland	marcin.bilski@im.uj.edu.pl
Bodin	Arnaud	Université Lille 1	France	Arnaud.Bodin@math.univ-lille1.fr
Boucher	Delphine	Université de Rennes 1 - IRMAR	France	delphine.boucher@univ-rennes1.fr
Boudaoud	Fatima	Université d'Oran Es senia	Algeria	fboudaoud@yahoo.fr
Broecker	Ludwig	Universität Münster	Germany	broe@uni-muenster.de
Brogli	Fabrizio	Università di Pisa	Italy	brogli@dm.unipi.it
Brugallé	Erwan	Institut Mathématiques de Jussieu	France	brugalle@math.jussieu.fr
Buresi	Jérôme	Université d'Artois	France	jerome.buresi@univ-artois.fr
Burgdorf	Sabine	Universität Konstanz	Germany	sabine.burgdorf@uni-konstanz.de
Cafuta	Kristijan	University of Ljubljana	Slovenia	kristijan.cafuta@fe.uni-lj.si
Casale	Guy	Université de Rennes 1 - IRMAR	France	guy.casale@univ-rennes1.fr
Catanese	Fabrizio	Universität Bayreuth	Germany	Fabrizio.Catanese@uni-bayreuth.de
Chen	Ying	Université de Lille 1	France	topspeed_cy@hotmail.com
Chevallier	Benoît	Université Toulouse II-le Mirail	France	chevalli@univ-tlse2.fr
Cimpric	Jaka	University of Ljubljana	Slovenia	cimpric@fmf.uni-lj.si
Cogan	Yann	Université Bretagne Occidentale	France	yann.cogan.29@gmail.com
Comte	Georges	Université de Savoie	France	georges.comte@univ-savoie.fr
Coppens	Marc	KHKempen/KULeuven	Belgium	marc.coppens@khk.be
Coste	Michel	Université de Rennes 1 - IRMAR	France	michel.coste@univ-rennes1.fr
Cucker	Felipe	City University of Hong Kong	Hong Kong	macucker@cityu.edu.hk
Degtyarev	Alex	Bilkent University	Turkey	degt@fen.bilkent.edu.tr
Delzell	Charles	Louisiana State University	USA	delzell@math.lsu.edu
Denkowska	Zofia	Université d'Angers - LAREMA	France	denkows@univ-angers.fr



Dias	Luis Renato Gonçalves	Université de Lille 1	France	dias@math.univ-lille1.fr
Dickmann	Max	Institut de Mathématiques de Jussieu	France	dickmann@logique.jussieu.fr
Domanski	Pawel	Adam Mickiewicz University	Poland	domanski@amu.edu.pl
Dutertre	Nicolas	Université de Provence	France	dutertre@cmi.univ-mrs.fr
Efrat	Ido	Ben-Gurion University of the Negev	Israel	efrat@math.bgu.ac.il
El Boukhary	Mohamed	Mohammed 1st University	Morocco	ouldemane@gmail.com
ElKhadiri	Abdelhafed	University Ibn Tofail	Morocco	kabdelhafed@hotmail.com
Fekak	Azzeddine	Ecole Royale Navale Casablanca	Morocco	fekak.azed@hotmail.com
Fernando Galvan	Jose F.	Universidad Complutense de Madrid	Spain	josefer@mat.ucm.es
Fichou	Goulwen	Université de Rennes 1 - IRMAR	France	goulwen.fichou@univ-rennes1.fr
Fiedler	Séverine	/	France	severine.fiedler@live.fr
Finashin	Sergey	Middle East Technical University	Turkey	serge@metu.edu.tr
Gabrielov	Andrei	Purdue University	USA	agabriel@math.purdue.edu
Ghiloni	Riccardo	University of Trento	Italy	ghiloni@science.unitn.it
Gladki	Pawel	University of Silesia	Poland	pawel.gladki@us.edu.pl
Goel	Charu	University of Konstanz	Germany	charu.goel@uni-konstanz.de
Gondard	Danielle	Université Pierre et Marie Curie	France	gondard@math.jussieu.fr
Gonzalez-Lopez	Maria Jose	Universidad de Cantabria	Spain	gonzalelm@unican.es
Gonzalez-Vega	Laureano	Universidad de Cantabria	Spain	laureano.gonzalez@unican.es
Grigoriev	Dima	Université de Lille 1	France	Dmitry.Grigoryev@math.univ-lille1.fr
Hanselka	Christoph	Universität Konstanz	Germany	christoph.hanselka@uni-konstanz.de
Huisman	Johannes	Université de Brest	France	johannes.huisman@univ-brest.fr
Ibrahim	Adamou	University of Cantabria	Spain	ibrahim.adamou@unican.es
Itenberg	Ilia	Université de Strasbourg	France	ilia.itenberg@math.unistra.fr
Kharlamov	Viatcheslav	Université de Strasbourg	France	viatcheslav.kharlamov@math.unistra.fr
Klep	Igor	University of Ljubljana	Slovenia	igor.klep@fmf.uni-lj.si
Krzyzanowska	Iwona		Poland	iwona.krzyzanowska@mat.ug.edu.pl
Kucharz	Wojciech	Jagiellonian University	Poland	Wojciech.Kucharz@im.uj.edu.pl
Kunert	Aaron	University Konstanz	Germany	Aaron.Kunert@uni-konstanz.de
Kurdyka	Krzysztof	Université de Savoie	France	kurdyka@univ-savoie.fr
Lavi	Noa	Ben-Gurion University of the Negev	Israel	lano@math.bgu.ac.il
Le Gal	Olivier	/	/	olegal@agt.uva.es
Lerario	Antonio	Sissa	Italy	lerario@sissa.it
Limoges	Thierry	Université de Nice	France	thierry.limoges@unice.fr
Lion	Jean-Marie	Université de Rennes 1 - IRMAR	France	jean-marie.lion@univ-rennes1.fr
Lombardi	Henri	Université de Franche-Comté	France	henri.lombardi@univ-fcomte.fr
Maciejewski	Lukasz	Jagiellonian University	Poland	lukasz.maciejewski@im.uj.edu.pl
Mahboubi	Assia	INRIA Saclay	France	Assia.Mahboubi@inria.fr

Mahé	Valéry	Université de Franche-Comté	France	Valery.Mahe@univ-fcomte.fr
Mahé	Louis	Université de Rennes 1 - IRMAR	France	louis.mahe@univ-rennes1.fr
Mangolte	Frédéric	Université d'Angers	France	frederic.mangolte@univ-angers.fr
Matusinski	Mickaël	Université de Versailles	France	mickael.matusinski@math.uvsq.fr
Michalska	Maria	Universite de Savoie/University of Lodz	Poland	Maria.Michalska@univ-savoie.fr
Moncet	Arnaud	Université de Rennes 1 - IRMAR	France	arnaud.moncet@univ-rennes1.fr
Monnier	Jean-Philippe	Université d'Angers	France	monnier@tonton.univ-angers.fr
Mourougane	Christophe	Université de Rennes 1 - IRMAR	France	christophe.mourougane@univ-rennes1.fr
Moussa	Seydou	Université de Maradi	Niger	seydmoussa@yahoo.fr
Netzer	Tim	Universitaet Leipzig	Germany	tim.netzer@math.uni-leipzig.de
Nguyen	Ha	Wesleyan College	USA	n_n_ha@yahoo.com
Nguyen	Vu	/	USA	stoooidsavant@gmail.com
Nguyen Thi Bich	Thuy	Université de la Méditerranée	France	thuy.nguyen-thi-bich@etumel.univmed.fr
Nicoara	Andreea	University of Pennsylvania	USA	anicoara@math.upenn.edu
Nowak	Krzysztof	Jagiellonian University	Poland	nowak@im.uj.edu.pl
Nowel	Aleksandra	University of Gdansk	Poland	olanowel@mat.ug.edu.pl
Parusinski	Adam	Université de Nice	France	adam.parusinski@unice.fr
Pawlucki	Wieslaw	Jagiellonian University	Poland	Wieslaw.Pawlucki@im.uj.edu.pl
Pecker	Daniel	Université Paris 6	France	pecker@math.jussieu.fr
Pernazza	Ludovico	Università di Pavia	Italy	ludovico.pernazza@unipv.it
Pfister	Albrecht	Mathematisches Institut/ Universität Mainz	Germany	pfister@mathematik.uni-mainz.de
Plaumann	Daniel	Universität Konstanz	Germany	Daniel.Plaumann@uni-konstanz.de
Powers	Victoria	Emory University	USA	vicki@mathcs.emory.edu
Prelli	Luca	Università degli Studi di Padova	Italy	lprelli@math.unipd.it
Prestel	Alexander	University of Konstanz	Germany	alex.prestel@uni-konstanz.de
Priziac	Fabien	Université de Rennes 1 - IRMAR	France	fabien.priziac@univ-rennes1.fr
Quarez	Ronan	Université de Rennes 1 - IRMAR	France	ronan.quarez@univ-rennes1.fr
Rainer	Armin	University of Vienna	Austria	armin.rainer@univie.ac.at
Randriambo-lolona	Serge	the University of Western Ontario	Canada	srandria@uwo.ca
Recio	Tomas	Universidad de Cantabria	Spain	tomas.recio@unican.es
Reznick	Bruce	University of Illinois	USA	reznick@math.uiuc.edu
Risler	Jean-Jacques	IMJ, UPMC (Paris 6)	France	risler@math.jussieu.fr
Rolin	Jean-Philippe	Université de Bourgogne	France	rolin@u-bourgogne.fr
Roy	Marie-Françoise	Université de Rennes 1 - IRMAR	France	marie-francoise.roy@univ-rennes1.fr
Rusek	Kamil	Jagiellonian University	Poland	Kamil.Rusek@im.uj.edu.pl

Scheiderer	Claus	Universität Konstanz	Germany	claus.scheiderer@uni-konstanz.de
Schlichting	Marco	University of Warwick	United Kingdom	m.schlichting@warwick.ac.uk
Schweighofer	Markus	Universität Konstanz	Germany	markus.schweighofer@uni-konstanz.de
Servi	Tamara	Universidade de Lisboa	Portugal	tamara.servi@gmail.com
Sfouli	Hassan	Université Ibn Tofail	Morocco	hassansfouli@hotmail.com
Shiota	Masahiro	Nagoya University	Japan	shiota@math.nagoya-u.ac.jp
Sinn	Rainer	Universität de Konstanz	Germany	rainer.sinn@uni-konstanz.de
Srhir	Ahmed	Faculté Poly-disciplinaire de safi Université Cadi Ayyad	Morocco	ahmedsrhir@hotmail.com
Szafraniec	Zbigniew	Uniwersytet Gdański	Poland	szafran@mat.ug.edu.pl
Szpirglas	Aviva	Université de Poitiers	France	Aviva.Szpirglas@math.univ-poitiers.fr
Tabera	Luis Felipe	Universidad de Cantabria	Spain	taberalf@unican.es
Tibar	Mihai	Université Lille 1	France	tibar@math.univ-lille1.fr
Tripathi	Girja	Louisiana State University, Tata Institute	USA	girja@math.lsu.edu
Trotman	David	Université Aix-Marseille	France	trotman@cmi.univ-mrs.fr
Tuan Hiep	Dang	Dipartimento di Matematica, Università degli Studi di Bari	Italy	dang@dm.uniba.it
Ueno Jacue	Carlos	Universidad Complutense de Madrid	Spain	carlos.ueno@terra.es
Unger	Thomas	University College Dublin	Ireland	thomas.unger@ucd.ie
Uribe Vargas	Ricardo	Université de Bourgogne	France	r.uribe-vargas@u-bourgogne.fr
Valette	Guillaume	Polish Academy of Science	Poland	gvalette@impan.pl
Valette	Anna	Uniwersytet Jagiellonski	Poland	anna.valette@im.uj.edu.pl
Vera Pacheco	Franklin	University of Toronto	Canada	franklin.vp@gmail.com
Vinzant	Cynthia	University of California, Berkeley	USA	cvinzant@math.berkeley.edu
Vorobjov	Nicolai	University of Bath	United Kingdom	nrv@cs.bath.ac.uk
Welschinger	Jean-Yves	Université Lyon 1 / CNRS	France	welschinger@math.univ-lyon1.fr
Wenzel	Sebastian	Konstanz	Germany	Sebastian.wenzel@uni-konstanz.de
Zell	Thierry	Lenoir-Rhyne University	USA	thierry.zell@lr.edu



