



HAL
open science

Strong edge-colouring and induced matchings

Hervé Hocquard, Pascal Ochem, Petru Valicov

► **To cite this version:**

Hervé Hocquard, Pascal Ochem, Petru Valicov. Strong edge-colouring and induced matchings. 2011.
hal-00609454v1

HAL Id: hal-00609454

<https://hal.science/hal-00609454v1>

Preprint submitted on 19 Jul 2011 (v1), last revised 28 Jul 2013 (v4)

HAL is a multi-disciplinary open access archive for the deposit and dissemination of scientific research documents, whether they are published or not. The documents may come from teaching and research institutions in France or abroad, or from public or private research centers.

L'archive ouverte pluridisciplinaire **HAL**, est destinée au dépôt et à la diffusion de documents scientifiques de niveau recherche, publiés ou non, émanant des établissements d'enseignement et de recherche français ou étrangers, des laboratoires publics ou privés.

Strong edge coloring and induced matchings[☆]

Hervé Hocquard^a, Pascal Ochem^b, Petru Valicov^a

^aLaBRI (Université Bordeaux 1), 351 cours de la Libération, 33405 Talence Cedex, France

^bLRI - CNRS, Bât 490 Université Paris-Sud 11, 91405 Orsay Cedex, France

Abstract

A strong edge coloring of a graph G is a proper edge coloring such that every path of three edges uses three colors. An induced matching of a graph G is a subset \mathcal{I} of edges of G such that the graph induced by \mathcal{I} is a matching. In this paper, we prove the NP-completeness of strong edge 4, 5 and 6-coloring and maximum induced matching in the case of some restricted subclasses of subcubic planar graphs. We also obtain a tight upper bound for the minimum number of colors in a strong edge coloring of outerplanar graphs as a function of the maximum degree.

Key words: NP-complete, strong edge coloring, induced matching, planar graphs, outerplanar graphs.

1. Introduction

A proper edge coloring of a graph $G = (V, E)$ is an assignment of colors to the edges of the graph such that two adjacent edges do not use the same color. A *strong edge coloring* (called also distance 2 edge coloring) of a graph G is a proper edge coloring of G , such that any edge of a path of length 3 ($uvxy$) uses three different colors. We denote by $\chi'_s(G)$ the *strong chromatic index* of G which is the smallest integer k such that G can be strong edge colored with k colors. The *girth* of a graph is the size of a shortest cycle in this graph. We denote Δ as being the maximum degree of a graph. We will say that two edges uv and xy are at distance 2 if there exists a path of length 3 - $uvxy$.

Strong edge coloring seems to be introduced by Fouquet and Jolivet in [5, 6]. For a brief survey of applications of this type of coloring and some open questions, we refer the reader to [10, 13]. In 1985, during a seminar in Prague, Erdős and Nešetřil gave a construction of graphs having strong chromatic index equal to $\frac{5}{4}\Delta^2$ when Δ is even and $\frac{1}{4}(5\Delta^2 - 2\Delta + 1)$ when Δ is odd. They conjectured that the strong chromatic index is bounded by these values and it was verified for $\Delta \leq 3$. Faudree *et al.* [3] conjectured that every bipartite graph has a strong edge coloring with Δ^2 colors. In [4] the same authors stated a new conjecture, claiming that the strong chromatic index of planar subcubic graphs is at most 9 and proved that $\chi'_s(G) \leq 4\Delta + 4$, for $\Delta \geq 3$. In this paper we improve the latter result in the case of outerplanar graphs, showing that for an outerplanar graph G , $\chi'_s(G) \leq 3\Delta - 3$, for $\Delta \geq 3$. The interest of this bound is motivated by the existence of a class of outerplanar graphs having $\chi'_s(G) = 3\Delta - 3$, for any $\Delta \geq 3$.

Mahdian proved in [11] that deciding whether a bipartite graph with girth g is strongly edge k -colorable, $\forall k \geq 4$, is NP-complete. In this paper we prove the NP-completeness of the problems of deciding whether a planar subcubic bipartite graph can be strong edge colored with four, five and six colors, for some values of the girth.

A related notion to strong edge coloring is the *induced matching*. An induced matching of G is a set of non-adjacent edges (matching) such that no two of them are joined by an edge in G . Clearly, the strong edge coloring is a partition of the set of edges into a collection of induced matchings (see [3, 4]). Cameron proved [1] that finding a maximum induced matching in chordal graphs can be done in polynomial time and that the problem is NP-complete for bipartite graphs for every girth g . Lozin proved in [9] that deciding whether a set of edges is a maximum induced matching

[☆]This research is supported by the ANR GraTel ANR-blan-09-blan-0373-01 and NSC99-2923-M-110-001-MY3 and the ANR GRATOS ANR-09-JCJC-0041-01.

is NP-complete for bipartite graphs of maximum degree 3. Duckworth *et al.* proved in [2] that the problem is NP-complete even when restricted to planar cubic graphs. We strengthen these results by proving that the problem remains NP-complete even if it is restricted to bipartite planar graphs with maximum degree 3 with girth g for any fixed g .

2. Strong-edge colouring

2.1. NP-completeness for subcubic planar graphs

The STRONG EDGE k -COLORING problem is defined as follows:

INSTANCE: A graph G .

QUESTION: Does G have a strong edge coloring with k colors?

The 3-COLORING problem is defined as follows:

INSTANCE: A graph G .

QUESTION: Does G have a proper coloring with three colors?

3-COLORING is known to be NP-complete even when restricted to planar graphs with maximum degree 4 [7].

Theorem 1. *STRONG EDGE 4-COLORING is NP-complete for planar bipartite graphs with maximum degree 3 and any fixed girth.*

Proof

The problem is in NP since we can check in polynomial time whether a given edge coloring is a strong edge coloring. We will prove the theorem by reduction from 3-COLORING of planar graphs of degree 4.

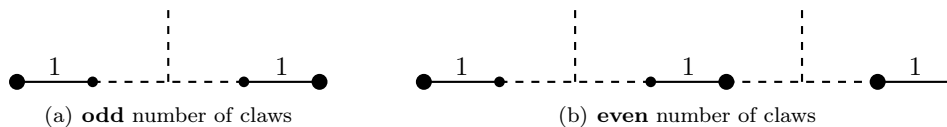

Figure 1: Transportation of a color

First, observe that by using the graphs in Figures 1(a) and 1(b), we can force the edges at arbitrarily large distance to have the same color if we put a sufficient number of claws between them (the dotted part of the figures). Moreover, depending on the parity of the number of claws between the edges having the same color in a strong edge coloring, we can force vertices incident to these edges to be in the same part or in distinct parts of the bipartition. As an illustration in the Figures 1(a) and 1(b), the bipartition is given by small and big vertices.

Given a planar graph G with maximum degree 4, we construct a graph G' as follows. Every vertex v in G is replaced by a copy Q_v of the graph Q depicted in Figure 2(b) which contains three copies of the graph M shown in Figure 2(a). Note that M is bipartite (the bipartition is given in the picture by the big and small vertices) and of arbitrarily large girth. Therefore Q is bipartite and of arbitrarily large girth.

For every edge uv in G , we connect x_i of Q_u with x_j of Q_v and one of the vertices y_i^1, y_i^2 with one of the vertices y_j^1, y_j^2 such that the obtained graph is planar. These connections are done using an arbitrarily large number of claws as depicted in Figure 3. It is easy to see that choosing the parity of the number of claws connecting these vertices, the obtained graph G' is bipartite and with an arbitrarily large girth. Moreover, all these connections can be done such that G' is planar.

Up to permutation of colors, the strong edge 4-coloring of M given in Figure 2(a) is unique. We say that the *color of Q* is the color of the edges incident to the vertices x_i in Q (color 2 in Figure 2(a)). Also, the *forbidden color of Q* is the color of the edges incident to y_i^1 and y_i^2 (color 3 in Figure 2(a)).

Figure 3 shows that for every edge $uv \in G$, Q_u and Q_v have distinct colors and the same forbidden color. Since G is connected, all copies of Q have same forbidden color, say 3, and thus no copy of Q is colored 3.

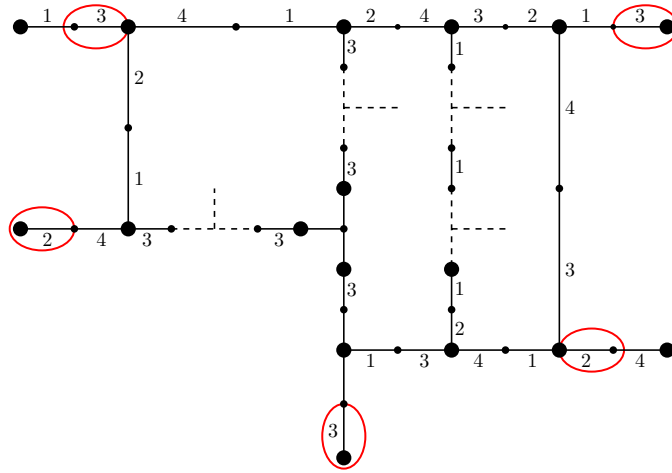

(a) Graph M

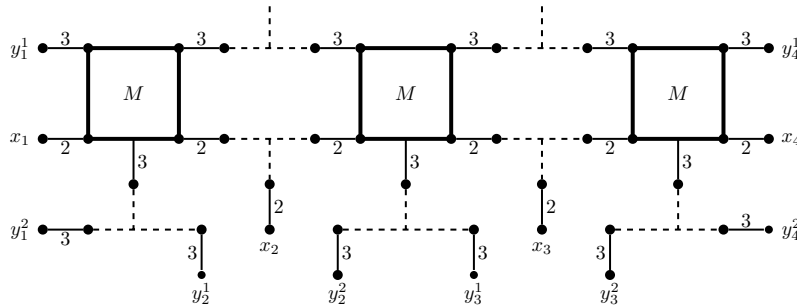

(b) Graph Q

Figure 2: Vertex gadget for Theorem 1

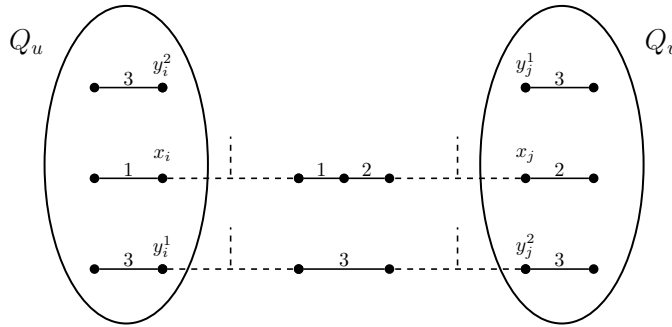

Figure 3: Edge gadget for Theorem 1

If G is 3-colorable, then for every vertex $v \in G$, we can assign the color of v to Q_v and extend this to a strong edge 4-coloring of G' . Conversely, given a strong edge 4-coloring of G' , we obtain a 3-coloring of G by assigning the color of Q_v to the vertex v . So G' is strong edge 4-colorable if and only if G is 3-colorable, which completes the proof. \square

Theorem 2. *STRONG EDGE 5-COLORING is NP-complete for planar bipartite graphs with maximum degree 3 and girth 8, and for planar graphs with maximum degree 3 and girth 9.*

Proof

In the following we will give the proof for the case of girth 8 since the same argument applies for the case of girth 9.

The problem is clearly in NP since it can be checked in polynomial time whether a given edge

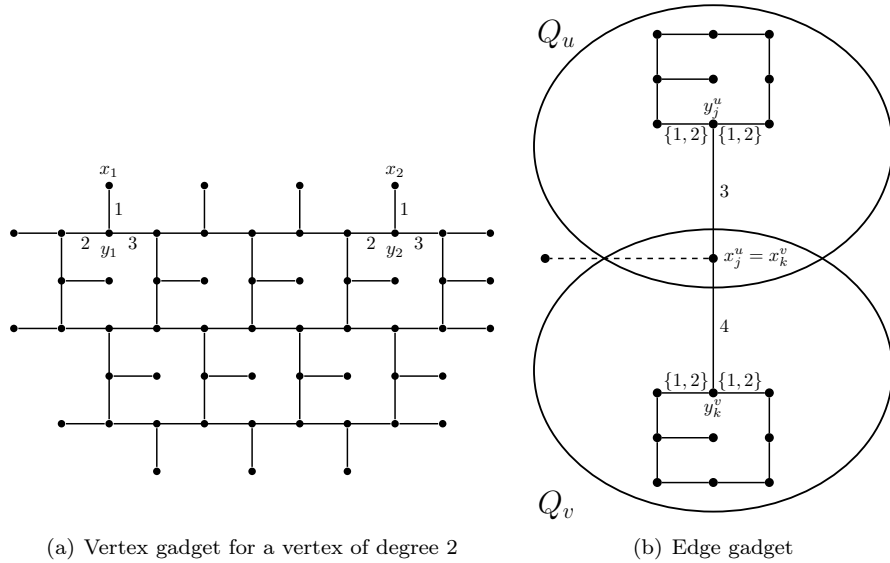

Figure 4: Vertex and edge gadgets for the case of girth 8 of Theorem 2

coloring is a strong edge coloring. As in the case of Theorem 1, we will reduce 3-COLORING of planar graphs of degree 4 to STRONG EDGE 5-COLORING.

Given a planar graph G with maximum degree 4, we construct a graph G' as follows. Every vertex v in G is replaced by a copy Q_v of the vertex gadget Q depicted in Figure 4(a). For every edge uv in G , we identify a vertex x_i of Q_u with a vertex x_j of Q_v and add a vertex of degree adjacent to the common vertex of Q_u and Q_v , as depicted in Figure 4(b). We identify vertices in such a way that the obtained graph G' is planar. Small and big vertices in Figures 4(a) and 4(b) show that G' is bipartite. Moreover, G' has no cycle of size strictly less than eight, hence G' has girth eight.

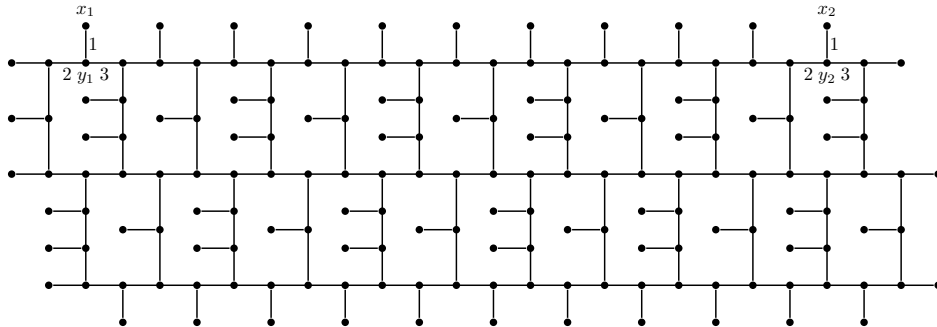

Figure 5: Vertex gadget for the case of girth 9 of Theorem 2

Up to permutation of colors, the strong edge 5-coloring of Q given in Figure 4(a) is unique. We say that the *color of Q* is the color of the edges $x_i y_i$ in Q (color 1 in Figure 4(a)). Also, the *forbidden colors of Q* are the colors of the edges incident to y_j in Q , different from $x_i y_i$ (colors 1 and 2 in Figure 4(a)). Figure 4(b) shows that for every edge $uv \in G$, Q_u and Q_v have distinct colors and same forbidden colors. Since G is connected, all copies of Q have same forbidden colors, 1 and 2, and thus no copy of Q is colored 1 or 2.

If G is 3-colorable, then for every vertex $v \in G$, we can assign the color of v to Q_v and extend this to a strong edge 5-coloring of G' . Conversely, given a strong edge 5-coloring of G' , we obtain a 3-coloring of G by assigning the color of Q_v to the vertex v . So G' is strong edge 5-colorable if and only if G is 3-colorable, which completes the proof.

For the case of girth 9 the same argument applies by using as a vertex gadget the graph of Figure 5, the edge gadget being the same. However, checking the strong edge colouring of this

gadget is much more tedious than in the case of the vertex gadget of girth 8. □

Theorem 3. *STRONG EDGE 6-COLORING is NP-complete for planar bipartite graphs with maximum degree 3.*

Proof

The problem is clearly in NP since it can be checked in polynomial time whether a given edge coloring is a strong edge coloring. Again, we prove the theorem by reduction from 3-COLORING of planar graphs with maximum degree 4. For a graph G of instance of 3-COLORING of planar graphs with maximum degree 4 we will give a construction of a graph G' such that G is 3-colorable if and only if G' is strong edge 6-colorable.

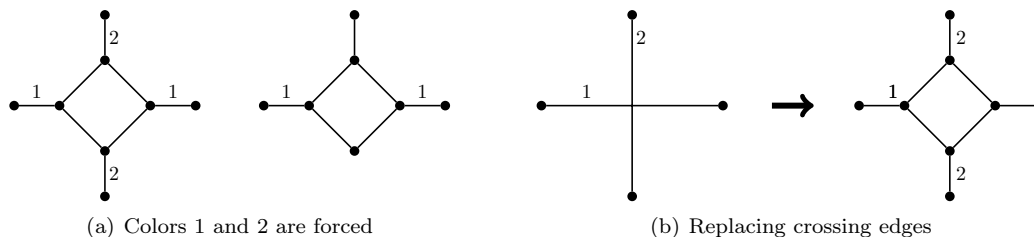

We first want to point out two easy but very useful observations.

Observation 1. *In any strong edge coloring with six colors of the graphs of Figure 6(a), the colors of the edges at distance 3 have to be the same (colors 1 and 2 are forced).*

Observation 2. *For any strong edge 6-colorable subcubic graph with an embedding such that two edges cross each other in the plane, there exists a strong edge 6-colorable subcubic planar graph obtained by replacing each crossing by a cycle of length four as depicted in Figure 6(b).*

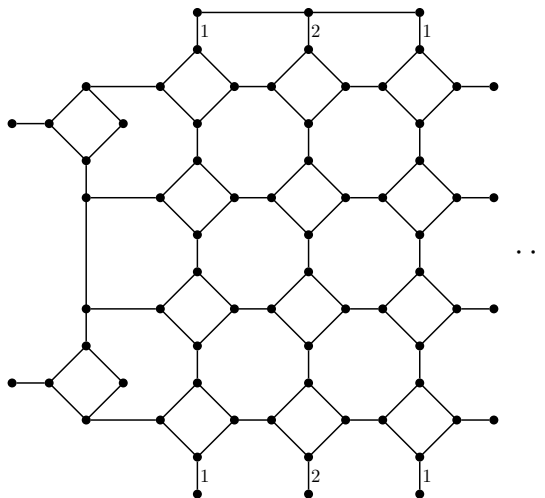

Figure 6: Graph P

Following Observation 1, in the graph P of Figure 6, up to a permutation, in any strong edge 6-coloring the colors 1 and 2 are forced. We call *pendant* edges the edges of P incident to a vertex of degree one and colored 1 and 2 in the figure. Note that P is bipartite.

Next, we construct the graph vertex-gadget as depicted in Figure 7. Note that the colors x, y, z, t in the figure are the colors which must be the same in any strong edge 6-coloring. Take two copies of graph P with six pairs of pendant edges (colored $\{x, y\}$ and $\{z, t\}$ respectively) and connect them such that the colors x, y, z, t are all different and the obtained graph has eight pairs

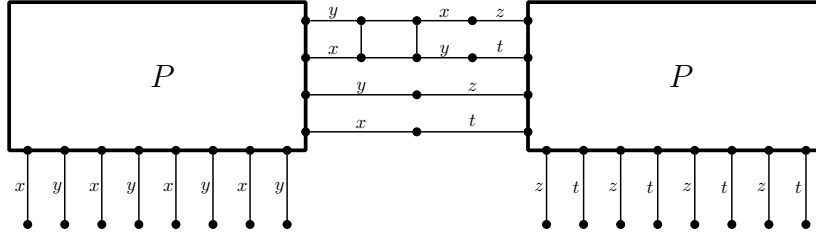

Figure 7: Vertex gadget Q for Theorem 3

of pendant edges. It is easy to see that the obtained graph Q is planar, bipartite, subcubic, and such that $\chi'_s(Q) = 6$.

Now, we build the vertex gadget *i.e.* the graph G_v that will replace a vertex v of G in G' . Take a copy of the graph Q and choose an embedding such that there are four quadruples of edges colored x, y, z and t in this order. Note that each crossing of edges is replaced by a cycle of length 4 following the Observation 2 such that the obtained graph is planar. Consider four pendant edges (one for each quadruple) of the obtained graph having the same color, say color x . For every of these edges, label its incident vertex of degree 1, x_k^v ($1 \leq k \leq 4$).

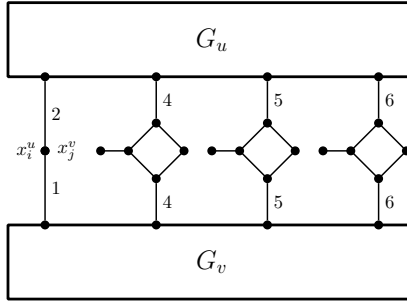

Figure 8: Edge gadget for Theorem 3 and its forced coloring

For an edge uv of G , in G' we identify the vertices x_i^u et x_j^v and connect the other three pairs of edges as shown in Figure 8. Note that if G' is connected, in any strong edge 6-coloring of G' the colors 4, 5 and 6 used in Figure 8 are not used to color any edge incident to some vertex labelled x_i^v .

We claim that the obtained graph G' is strong edge 6-colorable if and only if G is 3-colorable. Similar to the proof of Theorem 1, the forbidden colors in a strong edge 6-coloring of the graph G' are the colors of edges not incident to some vertex labelled x_i^v . Hence, in G' there are three forbidden colors. If G is 3-colorable then we can assign the color of a vertex v of G to the pendant edge G_v incident to x_i^v in G' and extend this coloring to a valid strong edge 6-coloring of G' . Conversely, given a strong edge 6-coloring of G' , since there are three forbidden colors for G' , we can use the color of the edge incident to x_i^v in the graph G_v to color v in G . \square

2.2. Outerplanar graphs

Theorem 4. For every outerplanar graph G with maximum degree $\Delta \geq 3$, $\chi'_s(G) \leq 3\Delta - 3$.

Proof

We define the partial order \preceq on graphs such that $G_1 \prec G_2$ if and only if

- $|E(G_1)| < |E(G_2)|$ or
- $|E(G_1)| = |E(G_2)|$ and G_1 contains strictly more pendant edges than G_2 .

Let $k \geq 3$ be an integer and G be an outerplanar graph with maximum degree k such that $\chi'_s(G) > 3k - 3$ and that is minimal with respect to \preceq .

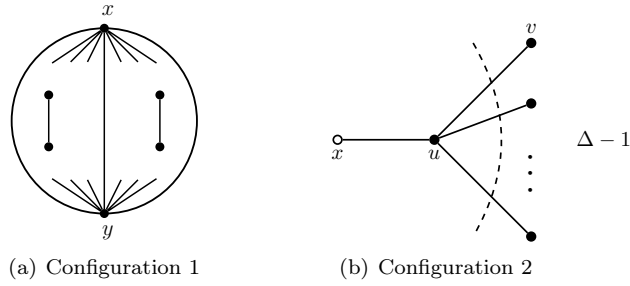

Figure 9: Forbidden configurations

We first show that G does not contain Configuration 1 depicted in Figure 9(a). That is, two adjacent vertices x and y , such that the graph G' obtained from G by removing the set S of edges incident to x or y contains two edges in distinct connected components.

Suppose that G contains Configuration 1. Let G_1, \dots, G_k be the connected components of G' . Since they contain fewer edges than G , by minimality of G with respect to \preceq , the graphs induced by the edges of $G_i \cup S$ admit a strong edge coloring with at most $3k - 3$ colors. Since the colors of the edges of S are distinct, we can permute the colors in the coloring of $G_i \cup S$ so that the coloring of S is the same in every $G_i \cup S$. By gluing up the graphs $G_i \cup S$, we obtain a valid strong edge coloring of G since the distance between an edge in G_i and an edge in $G_{i'}$ for $i \neq i'$ is at least three. This is a contradiction.

Configuration 2 depicted in Figure 9(b) consists of a vertex u adjacent to at most one vertex x with degree at least two and to at least one vertex v of degree one. The graph G does not contain Configuration 2 since otherwise we could obtain a coloring of G by extending a coloring of $G \setminus \{uv\}$.

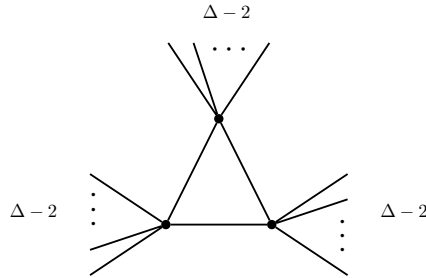

Figure 10: Example of outerplanar graph such that $\chi'_s(G) = 3\Delta - 3$.

Let G' be the graph induced by the vertices of G of degree at least 2. Since Configuration 2 is forbidden in G , G' has minimum degree 2. Since Configuration 1 is forbidden in G , G' is 2-connected and thus consists of a cycle C . Again, since Configuration 1 is forbidden in G , the chords of C join vertices at distance two in the cyclic order. It is easy to check that if C contains at most 4 vertices then the theorem holds. So C contains n vertices ($n \geq 5$) v_1, \dots, v_n in cyclic order and G is the cycle C having possibly some chords and with vertices adjacent to some vertices of degree 1 or not.

Let us suppose that C contains a chord, say the edge v_1v_3 . Notice that since Configuration 1 is forbidden, v_2 is only adjacent to v_1 and v_3 . The graph G' is obtained from G by splitting the vertex of degree 2 v_2 into v'_2 , which is only adjacent to v_1 , and v''_2 , which is only adjacent to v_3 . Notice that G' and G have the same number of edges but G' has two more pendant edges than G , so $G' \prec G$. The graph G' thus admits a valid strong edge coloring using $3k - 3$ colors and this coloring remains valid if we identify v'_2 and v''_2 to form G . This shows that the vertices of degree at least two in G form a chordless cycle.

To finish the proof, we have to consider only the worst case of graphs of this form, where every vertex on the chordless cycle is incident to $\Delta(G) - 2$ pendant edges. It is easy to check that if $\Delta(G) = k = 3$, then we can color G using at most $3k - 3 = 6$ colors. We iteratively construct a suitable coloring for larger values of k : when k is incremented by 1, there is at most one new

pendant edge for each vertex on the cycle and three more available colors. We use the three new colors to color the new edges such that two new edges incident to adjacent vertices get distinct colors.

□

3. Induced Matchings

The NP-complete problem PLANAR $(3, \leq 4)$ -SAT is defined as follows [8]:

INSTANCE: A collection \mathcal{C} of clauses over a set X of boolean variables, where each clause contains exactly three distinct literals (a variable x_i or its negation \bar{x}_i) and each variable appears at most four times, such that the variable-clause incidence graph is planar.

QUESTION: Can \mathcal{C} be satisfied, *i.e.*, is there a truth assignment of the variables of X such that each clause contains at least one true literal?

The INDUCED MATCHING problem is defined as follows:

INSTANCE: A graph G and an integer k .

QUESTION: Is there an induced matching of size k in G ?

Theorem 5. *INDUCED MATCHING is NP-complete for planar bipartite graphs with maximum degree 3 and any fixed girth.*

Proof

The problem is clearly in NP: given a subset of edges of G , one can check in polynomial time whether it is an induced matching of G by checking the distance in G between each pair of edges of this subset.

We reduce PLANAR $(3, \leq 4)$ -SAT to INDUCED MATCHING. We first prove the result for planar graphs with maximum degree 3 and girth 12 and then explain how to restrict further the proof to bipartite graphs with any fixed girth.

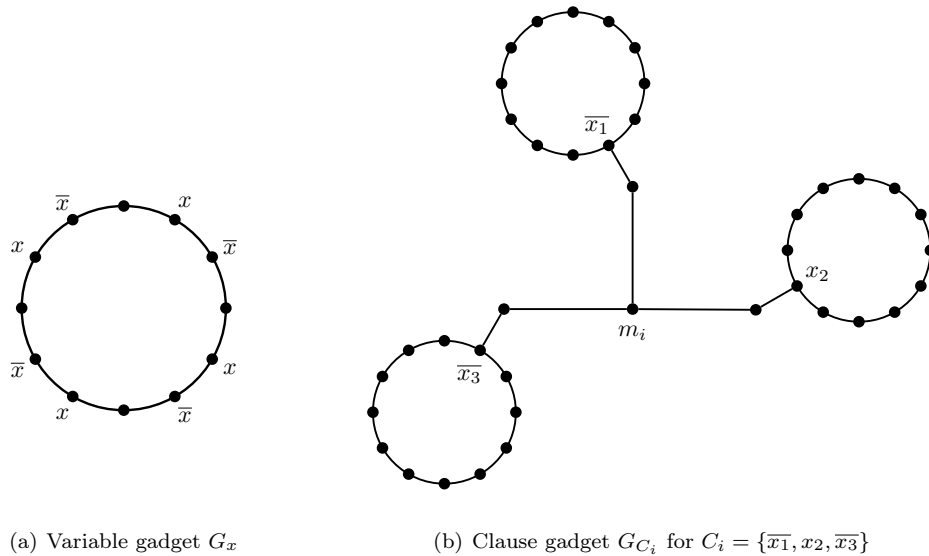

Figure 11: Variable and Clause gadgets

For an instance of PLANAR $(3, \leq 4)$ -SAT with a collection of clauses \mathcal{C} and a set X of boolean variables, we build the graph G as follows. For each variable, make a copy of the graph depicted in Figure 11(a). For each clause C_i , make a copy of the graph G_{C_i} by connecting each variable gadget as shown in Figure 11(b). It is easy to see that the construction of G can be done in polynomial in terms of the size of \mathcal{C} .

We show that \mathcal{C} is satisfiable if and only if G contains an induced matching \mathcal{I} of size $k = 4|X| + |\mathcal{C}|$.

Suppose \mathcal{C} is satisfiable. We build the induced matching \mathcal{I} of G as follows. For every variable subgraph G_x , we put in \mathcal{I} the four edges belonging to the cycle that are not incident to a vertex corresponding to a literal with boolean value TRUE.

For every clause subgraph G_{C_i} , we put in \mathcal{I} an edge incident to m_i and pointing in the direction of a literal with boolean value TRUE. Such a literal exists since the clause is satisfied. Clearly, \mathcal{I} is an induced matching and is of size k .

Suppose now that G has an induced matching \mathcal{I} of size k . We will show a truth assignment of the variables of X such that \mathcal{C} is satisfiable.

For each variable gadget, at most four edges belong to an induced matching of G . Hence, for every subgraph G_{C_i} , \mathcal{I} contains at least one of the edges incident to m_i . Then, \mathcal{I} contains exactly one of the edges incident to m_i (say e_i). Let l_j be the edge of a vertex gadget adjacent to e_i and therefore corresponding to a literal l_j . We build a set of edges \mathcal{I}' in the following way: for every clause gadget G_{C_i} , $e_i \in \mathcal{I}'$, and for every vertex gadget of G_{C_i} , add to \mathcal{I}' all the edges adjacent to \bar{l}_j and not adjacent to l_j . Clearly, \mathcal{I}' is an induced matching and $|\mathcal{I}'| = |\mathcal{I}|$. For every clause gadget G_{C_i} , assign the value TRUE to the literal represented by the edge adjacent to e_i . Hence every clause of \mathcal{C} has a TRUE literal and therefore \mathcal{C} is satisfiable.

In the proof above, the constructed graph is planar with maximum degree 3, but it is not bipartite and the girth is bounded (by 12). It is easy to see that it is possible to use cycles of size $6s$ for the variable gadgets and to branch the clause gadgets on them in such a way that the resulting graph is bipartite and has any given fixed girth. The reduction then uses $k = 2s|X| + |\mathcal{C}|$. \square

References

- [1] K. Cameron. Induced matchings, *Discrete Applied Mathematics* **24** (1989), 97-102.
- [2] W. Duckworth, D.F. Manlove and M. Zito. On the approximability of the maximum induced matching problem, *Journal of Discrete Algorithms* **3** (2005), 79-91.
- [3] R.J. Faudree, A. Gyárfas, R.H. Schelp and Zs. Tuza. Induced matchings in bipartite graphs, *Discrete Mathematics* **78** (1989), 83-87.
- [4] R.J. Faudree, A. Gyárfas, R.H. Schelp and Zs. Tuza. The strong chromatic index of graphs, *Ars Combinatoria* **29B** (1990), 205-211.
- [5] J.L. Fouquet and J.L. Jolivet. Strong edge-coloring of cubic planar graphs, *Progress in Graph Theory*, Academic Press, Canada (1984), 247-264.
- [6] J.L. Fouquet and J.L. Jolivet. Strong edge-colorings of graphs and applications to multi-k-gons, *Ars Combinatoria A* **16** (1983), 141-150.
- [7] M.R. Garey, D.S. Johnson and L.J. Stockmeyer. Some simplified NP-Complete graph problems, *Theoretical Computer Science* **1(3)** (1976), 237-267.
- [8] J. Kratochvíl. A special planar satisfiability problem and a consequence of its NP-Completeness, *Discrete Applied Mathematics* **52** (1994), 233-252.
- [9] V.V. Lozin. On maximum induced matchings in bipartite graphs, *Information Processing Letters* **81** (2002), 7-11.
- [10] M. Mahdian. The strong chromatic index of graphs, M.Sc. Thesis, Department of Computer Science, University of Toronto, 2000.
- [11] M. Mahdian. On the computational complexity of strong edge coloring, *Discrete Applied Mathematics* **118(3)** (2002), 239-248.
- [12] S.T. McCormick. Optimal approximation of sparse Hessians and its equivalence to a graph coloring problem, *Math. Programming* **26** (1983), 153-171.
- [13] D.B. West. Strong edge-coloring, Open Problems - Graph Theory and Combinatorics, <http://www.math.uiuc.edu/~west/openp/strongedge.html>